

2017 ▶ 2018
General Catalog



SUMITOMO

CARBIDE - CBN - DIAMOND

**HIGH PERFORMANCE
CUTTING TOOLS**

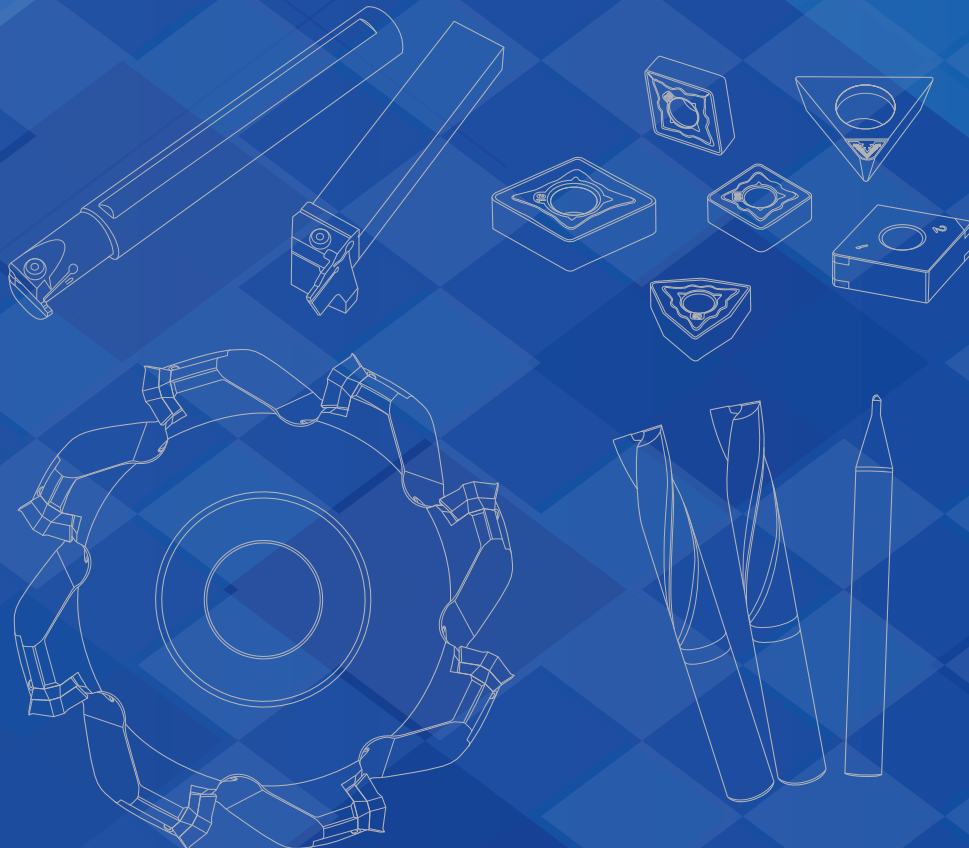
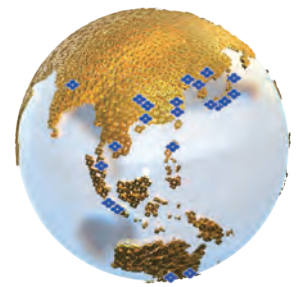



TABLE OF CONTENTS



Turning Systems

General Information	6-15
Indexable Inserts	16-141
Threading, Grooving, & Cut-Off Inserts.....	142-149
Ceramic Inserts	151-155
PCBN & PCD Inserts	156-195
Toolholders.....	196-216
Swiss Toolholders	217-238
Boring Bars	239-275
Threading, Grooving, & Cut-Off Holders.....	276-314

Milling Systems

Indexable Milling Selection Guide	328-329
Shoulder Milling.....	331-353
Face Milling	355-372
High Feed Milling	373-377
Multi-Purpose Milling.....	379-392
Modular Tooling.....	393-399
PCBN & PCD Milling	401-412
Discontinued Milling Items	413-425
Solid Carbide Endmills.....	427-439

Drilling Systems

Drill Selection Guide	442
Solid Carbide Drills:.....	443-473
Deep Hole Carbide Drills:	475-480
MicroDrills & DLC Coated Drills:	481-487
Replaceable Tip Drills:	489-499
Indexable Drills:	501-511
PDL/PCT	512-515
SR Reamer	516-526
ALMT Products	527-538

<u>Adaptors and Holders</u>	539-563
--	---------

Hardware/Reference

Technical Information & Hardware	564-620
--	---------

Offering our customers training courses to enhance customer satisfaction.

Please contact training@sumicarbide.com for registration & detailed curriculum of the all training courses.

A-TEC

Global Support. Global Solutions.

Sumitomo has established a global network of Tool Engineering Centers (TECs) to service industrial metalworking markets worldwide. Currently there are 10 locations globally with plans to add more every year.

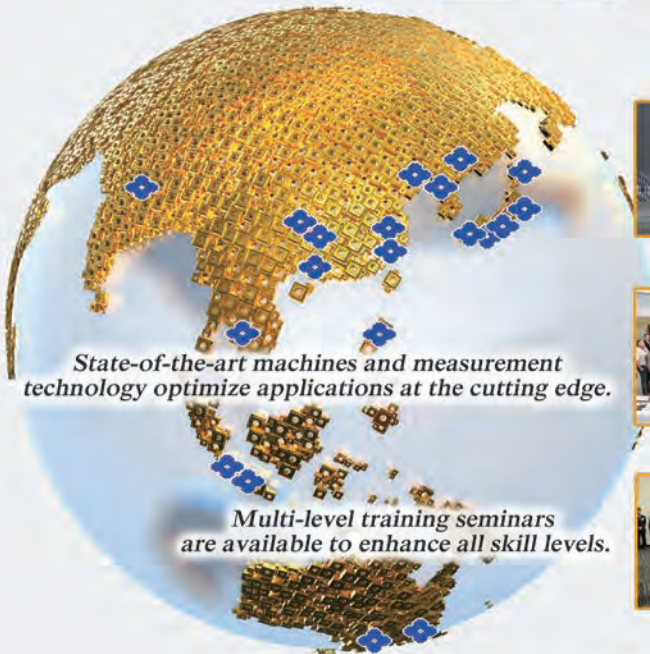

State-of-the-art machines and measurement technology optimize applications at the cutting edge.

Multi-level training seminars are available to enhance all skill levels.



Part runoffs are performed at our facilities to eliminate customer production interruptions when testing application improvements.



Tool Engineering Center



- Learn about machining concepts and state-of-the-art Sumitomo tooling!



- See the tooling in action!



FREE TRAINING

- See how the tools are made during our Plant Tours!

Contact us at training@sumicarbide.com for more information.



Come visit Sumitomo's Tooling Engineering Center (TEC) in New Berlin, Wisconsin!

- Training Seminars
- Part Runoffs
- Tooling and Application Optimization

A-TEC



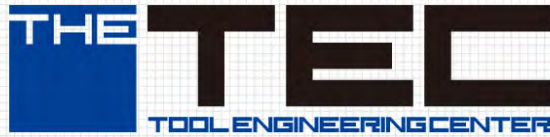

We strongly support our customers' CRAFTSMANSHIP!

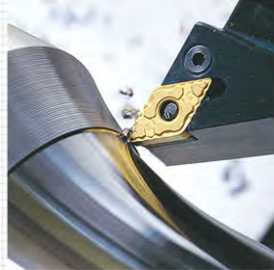

Sumitomo offers 3 courses to suit our customers' requirements and proficiency.

Course Name	Description	Trainee Level	Intended for		Course Duration
			Distribution	Endusers	
Level 1) Beginners' Course	<p>Beginners' Course is an entry-level course for those who are just starting to learn about cutting tools, like new employees or customer support staff.</p> <p>In this course, trainees will be introduced to different types of cutting tools and will also learn how to select required tools from the catalog.</p>	New employee, Customer support staff	○	-	1 Day
Level 2) Basic Course	<p>Level 2 training is catered for those with less than 5 years experience with cutting tools by providing an enjoyable learning experience through a mix of classroom and machine demos.</p> <p>In this course, trainees will learn, in an easy-to-understand way, the fundamentals of machining on a wide range of topics for turning, drilling, CBN and milling.</p>	Less than 5 years experience with cutting tools	○	○	2 Days
Level 3) Advanced Course	<p>Level 3 is a mix of Classroom and Machine Demos going over several troubleshooting and problem solving techniques. Team pick selecting cutting conditions and trying on machines. Each class has a theme and focus of either Milling, Drilling, Turning or CBN.</p>	More than 3 years experience with cutting tools	○	○	1 Day

Please contact training@sumicarbide.com for registration & detailed curriculum of the all training courses.



TURNING SYSTEMS

Turning



TURNING SYSTEMS	PAGES
General Information	6-15
Indexable Inserts.....	15-141
Threading, Grooving, & Cut-Off Inserts.....	143-149
Ceramic Inserts	151-155
PCBN & PCD Inserts.....	157-195
Toolholders.....	196-216
Swiss Toolholders	217-238
Boring Bars	239-275
Threading, Grooving, & Cut-Off Holders.....	276-314
Polygon Shank (PSC) Style Holders	315-325



CARBIDE - CBN - DIAMOND

1-800-950-5202

www.sumicarbide.com

GENERAL INFORMATION - TURNING

Pages 5-15



Turning

GENERAL INFORMATION	PAGES
Insert Nomenclature	6-7
Grade Descriptions	8-11
Chipbreaker Descriptions	12-13
Cutting Tool Selection	14-15



CARBIDE - CBN - DIAMOND

1-800-950-5202

www.sumicarbide.com

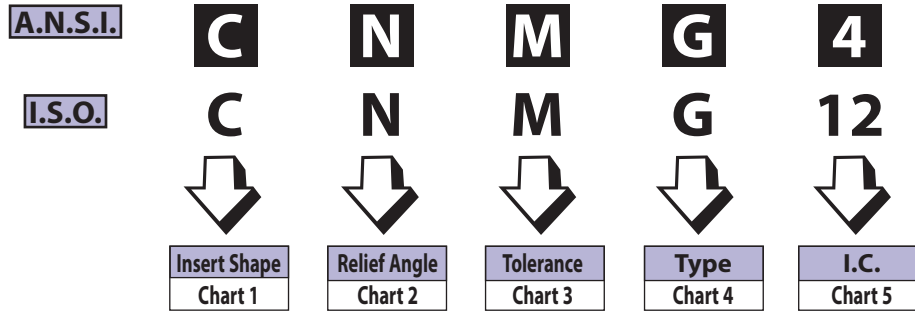

Chart 1 Insert Shape

Symbol	Insert Shape
V	35° Diamond
D	55° Diamond
T	60° Triangle
C	80° Diamond
W	80° Trigon
S	90° Square
R	Round
A, K, M	Parallelogram

Chart 2 Relief Angle







Symbol	Relief Angle
N	0° 
B	5° 
C	7° 
P	11° 
D	15° 
E	20° 
F	25° 

Chart 3 Tolerance

Symbol	Insert I.C.	Thickness	Nose Position
A	±.001	±.001	±.0002
C	±.001	±.001	±.0005
E	±.001	±.001	±.001
F	±.0005	±.001	±.0002
G	±.001	±.005	±.001
J	±.002	±.001	±.002
M	See Chart 3.1		
U	See Chart 3.1		

Chart 5 Inscribed Circle

Sumitomo Number	I.S.O. Number								
	SHAPE SIZE	R	S	T	C	D	V	W	I.C.
(5)				06				03	5/32"
(6)				08					3/16"
1.8				09					7/32"
		06							(.236)
2		06	11	06	07	11	04		1/4"
2.5		07		08	09				5/16"
		08							(.315)
3		09	09	16	09	11	16	06	3/8"
		10							(.394)
		12							(.472)
4		12	12	22	12	15	22	08	1/2"
5		15	15	27	16				5/8"
		16							(.630)
6		19	19	33	19				3/4"
		20							(.787)
		25							(.984)
8		25	25						1
		31							1-1/4"
		32							(1.260)

Chart 6 Thickness

Sumitomo Number	I.S.O. Number	Thickness
(2)	01	1/16"
1.5	02	3/32"
2	03	1/8"
2.5	T3	5/32"
3	04	3/16"
—	05	7/32"
4	06	1/4"
5	07	5/16"
5	08	5/16"
6	09	3/8"



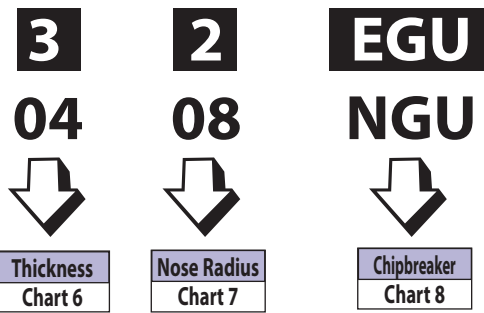

Chart 3.1 "M" and "U" Class Tolerance's

Symbol	Inscribed Circle		Nose Position Tolerance				Thickness
	M	U	M		U	M & U	
Shapes	All	All	S, T, C, R, W	D	V	All	All
I.C. Size							±.005
5/32 - 3/8	±.002	±.003	±.003	±.004	±.007	±.005	
7/16 - 9/16	±.003	±.005	±.005	±.006	±.010	±.008	
5/8 - 3/4	±.004	±.007	±.006	±.006	-	±.001	
7/8	±.006	±.010	±.006	±.006	-	±.015	
1	±.006	±.010	±.007	±.007	-	±.015	
1 1/4	±.006	±.010	±.008	±.008	-	±.015	

Chart 4

Symbol	Hole	Chipbreaker	Hole Style
A	Yes	No	Straight
G	Yes	Double	Straight
M	Yes	Single	Straight
N	No	No	None
R	No	Single	None
D	Yes	No	Countersunk
T	Yes	Single	Countersunk
X	Yes	10° Rake Angle	Straight or Countersunk
E	No	No	None

Chart 7 Nose Radius

Sumitomo Number	I.S.O. Number	Nose Radius
.001	003	.0012"
0	01	.0039"
0.5	02	.0079"
1	04	.0156"
—	05	.0197"
2	08	.0312"
—	10	.0394"
3	12	.0469"
—	15	.0591"
4	16	.0625"
6	24	.0938"
8	32	.1250"
—	40	.1575"

Chart 8 Chipbreaker

See Pages 9-10 for chipbreaker information.



CVD Coated Grades

Class	Grade	Hardness (HRA)	TRS (GPa)	Coating Type	Coating Thickness (µm)	Characteristics	Old Grades
P Steel	AC810P	91.0	2.2	Super FF Coat	18	A P10 grade with excellent wear resistance that features stability and longer tool life. Utilises a special carbide substrate with Super FF Coat for high to medium speed cutting.	AC700G
	AC820P	90.1	2.2	Super FF Coat	14	A P20 grade that features stability and longer tool life. Employs special carbide substrate and Super FF Coat to improve on P20 wear and fracture resistance.	AC2000
	<i>New</i> AC8025P	90.1	2.3	Absotech Platinum	12	A P25 Grade that features adhesion and chipping resistance, with a special carbide substrate and Absotech Platinum coating.	AC820P
	AC830P	89.4	2.6	Super FF Coat	8	Stable long-life grade employs special tough, carbide substrate and Super FF Coat. Improves on P30 grade fracture resistance and approaches P20 grade in terms of wear resistance.	AC3000
	AC630M	89.5	2.7	Super FF Coat	5	Superior performance in continuous and light cutting, and other low-speed applications that require sharp edges.	AC230
M Stainless Steel	AC610M	91.0	2.2	Super FF Coat	5	A high efficiency M10 grade featuring improved wear resistance during stainless steel cutting. Employs special, ultra-hard substrate and thin Super FF Coat.	—
	<i>New</i> AC6020M	90.1	2.3	Absotech Coat	5	A M20 Grade that features high chipping and wear resistance, with the Absotech Platinum coat that helps improve adhesion resistance	AC610M
	AC6030M	90.0	2.7	Absotech Coat	5	A general purpose grade featuring improved wear and fracture resistance during stainless steel cutting. Utilizes a special tough carbide substrate with our patented Absotech Coat.	AC630M
K Cast Iron	AC405K	92.0	2.4	Super FF Coat	18	Employs an ultra-hard substrate and ultra-hard Super FF Coating to provide excellent resistance to wear and plastic deformation. Suitable for high-speed continuous cutting of cast iron.	AC410K
	AC415K	91.1	2.5	Super FF Coat	18	Employs a special dedicated ultra-hard substrate that is also suitable for interrupted cutting and ultra-hard Super FF Coating to provide stability and long tool life. Recommended grade for cast iron turning.	AC410K
	AC420K	91.1	2.5	Super FF Coat	12	A new, extremely versatile grade that can be used for rough, interrupted cutting of ductile and grey cast iron. Employs special, ultra-hard carbide substrate and Super FF Coat to provide stability and long tool life.	AC700G
	AC820P	90.1	2.2	Super FF Coat	14	A grade suited to heavy interrupted cutting of ductile cast iron.	AC2000

PVD Coated Grades

Class	Grade	Hardness (HRA)	TRS (GPa)	Coating Type	Coating Thickness (µm)	Characteristics	Old Grades
P Steel	<i>New</i> T1500Z (Cermet)	92.0	2.2	Brilliant Coat	3	• Brilliant Coat PVD coating gives excellent lubricity for higher quality machining. General-purpose coated cermet grade that can maintain high-quality machined surfaces and also gives excellent wear resistance.	T2000Z
	T3000Z (Cermet)	91.3	2.4	ZX Coat	3	• An ultra-reliable coating grade with tough cermet substrate.	—
	AC530U	91.4	3.3	Super ZX Coat	3	• For interrupted and general steel cutting. • Utilizing the new super multi-layered PVD coating of nanometer thick TiAlN and AlCrN layers, coupled with a fine-grained super tough substrate for excellent fracture resistance.	ACZ310
	AC520U	91.7	3.0	Super ZX Coat	3	• Interrupted machining and stainless steel machining. • Utilizing the new super multi-layered PVD coating of nanometer thick TiAlN and AlCrN layers, coupled with a super tough substrate for excellent fracture resistance.	EH520Z EH20Z
M Stainless Steel	<i>New</i> AC6040M	91.4	3.8	Absotech Coat	3	• Heavy interrupted machining and stainless steel machining. • Utilizing the new super multi-layered PVD coating of nanometer thick TiAlN and AlCrN layers, coupled with a fine-grained super tough substrate for excellent fracture resistance.	ACZ310 AC530U
K Cast Iron	AC510U	92.6	2.6	Super ZX Coat	3	• General to interrupted machining of cast iron and ductile cast iron. • Utilizing the new super multi-layered PVD coating of nanometer thick TiAlN and AlCrN layers, coupled with a fine-grained super tough substrate for excellent fracture resistance.	EH510Z EH10Z
	AC510U	92.6	2.6	Super ZX Coat	3	• Finishing to medium cutting of exotic alloys. • Utilizing the new super multi-layered PVD coating of nanometer thick TiAlN and AlCrN layers. Superior wear and heat resistance, and stable, long tool life.	EH510Z EH10Z
S Exotic Alloy	AC520U	91.7	3.0	Super ZX Coat	3	• Medium to rough cutting of exotic alloys. • Utilizing the new super multi-layered PVD coating of nanometer thick TiAlN and AlCrN layers. Superior wear and heat resistance, and stable, long tool life even in interrupted cutting.	EH520Z EH20Z
	ACZ150	91.4	3.3	ZX Coat	1	• For small tools, and high-precision finishing to general finishing applications. • TiN ultra-thin coating and fine-grained, super tough substrate combine to give good edge sharpness and superior cut finish.	—



Ceramic Grades For Turning

Class	Grade	Hardness (HRA)	TRS (GPa)	Main Coating Components	Coating Thickness (μm)	Characteristics
K Cast Iron	SN200K	94.9	1.2	—	—	Contains Si ₃ N ₄ . Suitable for medium to finishing of cast iron.
S Exotic Alloy	SN1000S	93.0	0.76	—	—	SiAlON grade for high speed machining of Nickel-based alloys
	WX1500	94.4	—	—	—	Cold-pressed Whisker reinforced ceramic for high efficiency machining of hardened steels, and Ni and Co-based alloys
	SN2000S	94.6	7.2	—	—	Sialon designed for high speed roughing and semi finishing of high temperature alloys like Inconel 718.
	WX2000	90.0	1.2	—	—	Enhanced with SiC whiskers. For heat-resistant alloy and ultra-hard roll cutting.
	WX2500	—	—	—	—	Hot pressed Whisker reinforced designed for machining of high temperature alloys and hardened steel. Excellent thermal shock and crack resistance.
H Hardened Steel	NB150H	96.0	4.5	TiCN	—	Al ₂ O ₃ +TiCN Excellent wear resistance. The best choice for machining alloy steel and hardened steel
	NB90S	95.0	1.0	TiAlN	2	Ultra-strong. Contains Al ₂ O ₃ and ZX Coat. Continuous low-speed turning of hardened steel.

Ceramic Grades For Milling



Class	Grade	Hardness (HRA)	TRS (GPa)	Main Coating Components	Coating Thickness (μm)	Characteristics
K Cast Iron	SN2100K	93.2	0.7	—	—	Contains Si ₃ N ₄ . For high speed finish milling of cast iron.

Uncoated Carbide Grades

Application	Grade	Hardness (HRA)	TRS (GPa)	Young Modulus (GPa)	Thermal Conductivity (W/m.°C)	Compressive Strength (GPa)	Linear-Thermal Expansion Coefficient (X 10 ⁻⁶ /°C)
P Steel	A30N	91.2	2.2	520	-	-	-
M Stainless Steel	EH510	92.6	2.6	-	-	-	-
	EH520	91.7	3.0	-	-	-	-
K Cast Iron	BL130	94.3	2.9	-	-	-	-
	H1	92.9	2.1	650	109	6.1	4.7
	EH10	92.4	3.4	640	105	-	4.5
	EH510	92.6	2.6	-	-	-	-
	EH520	91.7	3.0	-	-	-	-
	G10E	91.1	2.2	620	105	5.7	-
N Non-Ferrous Metal	H10	91.1	2.2	620	105	5.7	-
	H1	92.9	2.1	650	109	6.1	4.7
S Exotic Alloy	EH510	92.6	2.6	-	-	-	-
	EH520	91.7	3.0	-	-	-	-



CBN Grades

Class	Grade	Binder	Carbon Content (%)	Grain Size (µm)	Hardness HV (GPa)	TRS (GPa)	Series	Characteristics	
	BNC2010	TiCN	50 to 55	2	30 to 32	1.10 to 1.20	Coated SUMIBORON (Coated)	Highly wear resistant coating makes this grade suited for high speed finishing.	
	BNC2020	TiN	70 to 75	5	34 to 36	1.20 to 1.30		High crater wear and breakage resistance make this grade suited for high load and interrupted cutting.	
	BNC100	TiN	40 to 45	1	29 to 32	1.05 to 1.15		Highly wear resistant coating makes this grade suited for high speed finishing.	
	BNC160	TiN	60 to 65	3	31 to 33	1.10 to 1.20		Stable, high precision finishing of hardened steel.	
	BNC200	TiN	65 to 70	4	34 to 36	1.15 to 1.25		Tough substrate with high wear resistant coating provide longer tool life.	
	BNC300	TiN	60 to 65	1	33 to 35	1.15 to 1.25		Suited for finishing when there is a combination of continuous and interrupted cutting.	
	Sintered Components	BNX10	TiCN	40 to 45	3	27 to 31	0.80 to 0.90	SUMIBORON (Uncoated)	Optimum wear resistance. Suited to continuous, high-speed cutting.
		BN1000	TiCN	40 to 45	1	27 to 31	0.90 to 1.00		Ultimate wear and fracture resistance. Suited to high-speed cutting.
		BNX20	TiN	55 to 60	3	31 to 33	0.95 to 1.10		Crater resistant grade, suitable for high efficiency cutting under high temperature conditions.
		BNX25	TiN	65 to 70	4	29 to 31	1.00 to 1.10		Excellent fracture resistance during high speed cutting. Suited to high speed interrupted cutting of hardened steel.
		BN2000	TiN	50 to 55	2	31 to 34	1.05 to 1.15		A general purpose grade for hardened steel that provides a high degree of fracture and wear resistance.
		BN350	TiN	60 to 65	1	33 to 35	1.20 to 1.30		High cutting edge strength, suited to heavy interrupted cutting.
BN7500		Co Compound	90 to 95	1	41 to 44	1.40 to 1.50	Maintains optimum cutting edge sharpness. Suited for finishing of sintered alloy.		
BN700		Co Compound	90 to 95	2	40 to 43	1.20 to 1.30	Maintains good wear and fracture resistance in rough cutting of sintered components.		
BN7000		Co Compound	90 to 95	2	41 to 44	1.30 to 1.40	Improved wear and fracture resistance in rough cutting of sintered components.		
		BN700	Co Compound	90 to 95	2	40 to 43	1.20 to 1.30		SUMIBORON (Uncoated)
	BN7000	Co Compound	90 to 95	2	41 to 44	1.30 to 1.40	Improved wear and fracture resistance in rough cutting of cast iron and exotic alloy.		
	BNS800	Al Alloy	85 to 90	8	39 to 42	0.95 to 1.10	100% solid CBN structure with good thermal impact resistance.		
	BNC500	TiC	60 to 65	4	32 to 34	1.00 to 1.10	Coated SUMIBORON (Coated)	Substrate with excellent wear resistance and coating makes this grade suited for hard-to-cut cast iron.	



PCD Grades

Class	Grade	Binder	Carbon Content (%)	Grain Size (µm)	Hardness HV (GPa)	TRS (GPa)	Characteristics
	DA1000	Co	90 to 95	Up to 0.5	110 to 120	≈ 2.60	High density sintered material made of ultra-fine diamond particles that demonstrates optimum wear and fracture resistance, and edge sharpness.
	DA2200	Co	85 to 90	0.5	90 to 100	≈ 2.45	Sintered material made of ultra-fine diamond particles that demonstrates optimum wear and fracture resistance, and edge sharpness.
	DA150	Co	85 to 90	5	100 to 120	≈ 1.95	Sintered material made of fine diamond particles that provides a good balance of workability and wear resistance.
	DA90	Co	90 to 95	50	100 to 120	≈ 1.10	Sintered material made of coarse diamond particles with high diamond content and excellent wear resistance.



(Bumpy breaker Standard breaker)

Turning

	Work Material					(Legend)		
	Steel	Stainless Steel	Cast Iron	Non-ferrous Metal	Exotic Metal	Hardened Steel		
	P	M	K	N	S	H		
Fine Finishing	EFA Type (20°) Depth of Cut (inches) Feedrate (IPR)	EFL Type (10°) Depth of Cut (inches) Feedrate (IPR)	EEF Type (20°) Depth of Cut (inches) Feedrate (IPR)					
Finishing	ESE Type (5°) Depth of Cut (inches) Feedrate (IPR)	ESEW Type (5°) Depth of Cut (inches) Feedrate (IPR)	ESU Type (13°) Depth of Cut (inches) Feedrate (IPR)	ELU Type (10°) Depth of Cut (inches) Feedrate (IPR)	ELUW Type (10°) Depth of Cut (inches) Feedrate (IPR)			
Light - Medium Cut	ESX Type (3°) Depth of Cut (inches) Feedrate (IPR)	EEX Type (16°) Depth of Cut (inches) Feedrate (IPR)	EUP Type (10°) Depth of Cut (inches) Feedrate (IPR)	EEG Type (30°) Depth of Cut (inches) Feedrate (IPR)				
Medium Cut	EGE Type (3°) Depth of Cut (inches) Feedrate (IPR)	EGU Type (7°) Depth of Cut (inches) Feedrate (IPR)	EGUW Type (0°) Depth of Cut (inches) Feedrate (IPR)	EUX Type (0°) Depth of Cut (inches) Feedrate (IPR)	ENG Type (4°) Depth of Cut (inches) Feedrate (IPR)	EGZ Type (0°) Depth of Cut (inches) Feedrate (IPR)		
Medium - Rough Cut	EME Type (4°) Depth of Cut (inches) Feedrate (IPR)	EMU Type (4°) Depth of Cut (inches) Feedrate (IPR)	EEM Type (0°) Depth of Cut (inches) Feedrate (IPR)	EMX Type (-15°) Depth of Cut (inches) Feedrate (IPR)	ENZ Type (4°) Depth of Cut (inches) Feedrate (IPR)			
Rough - Heavy Cut	EHG Type (0°) Depth of Cut (inches) Feedrate (IPR)	ENP Type (0°) Depth of Cut (inches) Feedrate (IPR)	EHP Type (0°) Depth of Cut (inches) Feedrate (IPR)					



Part Material



Steel
Stainless Steel
Cast Iron
Non-ferrous Metal
Exotic Metal
Hardened Steel

(Bumpy breaker Standard breaker)

Finishing	EFB Type 20° Depth of Cut (inches) vs Feedrate (IPR) graph	EFC Type (15°) Depth of Cut (inches) vs Feedrate (IPR) graph	EFP Type (10°) Depth of Cut (inches) vs Feedrate (IPR) graph	EFK Type (0°) Depth of Cut (inches) vs Feedrate (IPR) graph	FW Type (20°) Depth of Cut (inches) vs Feedrate (IPR) graph	FX Type (15°) Depth of Cut (inches) vs Feedrate (IPR) graph	FY Type (15°) Depth of Cut (inches) vs Feedrate (IPR) graph
	Finish - Light Cut	R/L-SD Type (0°) Depth of Cut (inches) vs Feedrate (IPR) graph	R/L-SDW Type (0°) Depth of Cut (inches) vs Feedrate (IPR) graph	R/L-w Type (10°) Depth of Cut (inches) vs Feedrate (IPR) graph	EFM Type (6°) Depth of Cut (inches) vs Feedrate (IPR) graph	ENK Type (8°) Depth of Cut (inches) vs Feedrate (IPR) graph	
Light Cut		ESU Type (8°) Depth of Cut (inches) vs Feedrate (IPR) graph	ELU Type (12°) Depth of Cut (inches) vs Feedrate (IPR) graph	ELUW Type (10°) Depth of Cut (inches) vs Feedrate (IPR) graph	NAG Type (20°) Depth of Cut (inches) vs Feedrate (IPR) graph	ENS Type (10°) Depth of Cut (inches) vs Feedrate (IPR) graph	
	Light~Medium Cut	ELB Type (15°) Depth of Cut (inches) vs Feedrate (IPR) graph	EMU Type (0°) Depth of Cut (inches) vs Feedrate (IPR) graph	ENF Type (0°) Depth of Cut (inches) vs Feedrate (IPR) graph			
Rough - Heavy Cut		MESI Type (15°) Depth of Cut (inches) vs Feedrate (IPR) graph					



Turning

P Steel						
Application	High Speed			Medium		
ISO Classification	-	P05	P10	P20	P30 (M30)	P40 (M40)
COATED CARBIDE	AC810P					
			AC820P			
			AC8025P			
				AC830P		
COATED CERMET	T1500Z					
			T3000Z			
CERMET	T1500A					
CERAMIC						
CARBIDE					A30	



K Cast Iron				
High Speed	Finishing	Medium		
—	K01	K10	K20	K30
	AC405K			
	AC415K			
		AC420K		
			AC820P	
	SN2000K			
	SN2100K			
		G10E		

M Stainless Steel		
Application	Finishing~Light Cut	Medium~Roughing
COATED CARBIDE	AC610M	
	AC6020M	
	AC630M	
	AC6030M	
	AC520U	
	AC6040M	
		AC530U
CERMET	T1500A	

S Exotic Material		
Application	Finishing~Light Cut	Medium
COATED CARBIDE	AC510U	
	AC520U	
	AC530U	
CARBIDE	EH510	
	EH520	
CERAMIC	SN1000S	
	WX1500	
	SN2000S	
	WX2500	
	WX2000	
CBN	BN7000	
		BNS800





Ceramic Grades

For Turning	High-Speed	Finishing to Light		Medium	Rough to Heavy	
	—	01	10	20	30	40
	SN2000K					
	SN1000S					
	WX1500					
	SN2000S					
	WX2500					
	WX2000					
	NB150H					
	NB90S					

For Milling	High-Speed	Finishing to Light		Medium	Rough to Heavy	
	—	01	10	20	30	40
	SN2100K					

Turning

CBN Grades

Class	Series	Finishing to Light		Medium	Rough to Heavy	
		H01	H10	H20	H30	
	Classification					
	Coated SUMIBORON	BNC2010		BNC2020		
		BNC100	BNC160			
				BNC200		BNC300
	Uncoated SUMIBORON	BNX10, BN1000		BN2000		
				BNX20		
				BNX25, BN350		
Sintered Components	Classification	01	10	20	30	
	Uncoated SUMIBORON			BN7000, BN700		
	Classification	K01	K10	K20	K30	
	Coated SUMIBORON	BNC500				
	Uncoated SUMIBORON			BN7000, BN700		
				BN7500		
				BNS800		





SUMITOMO

CARBIDE - CBN - DIAMOND

1-800-950-5202

www.sumicarbide.com

INDEXABLE INSERTS

Pages 17-141

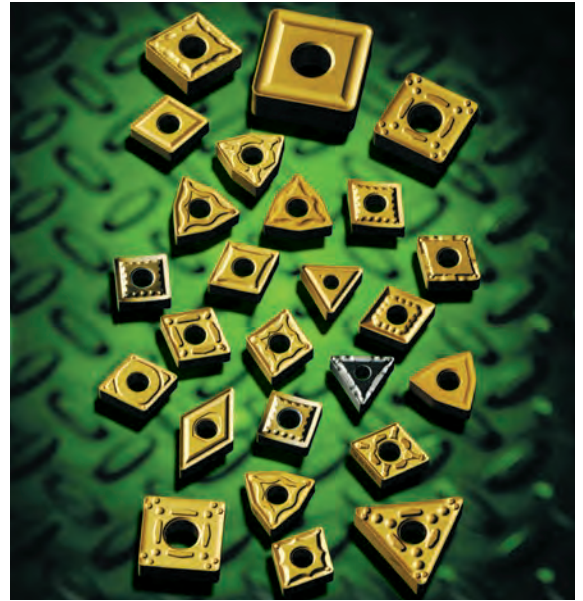

Negative
Inserts

INDEXABLE INSERTS

PAGES

Negative Inserts	17 - 86
Positive Inserts	87 - 138
Swiss Tooling Inserts.....	139 - 141

80° DIAMOND TYPE

NEGATIVE INSERT

Indexable Inserts for Turning

CN

80° Diamond Type
Negative
With Insert Hole

- P** Steel
- M** Stainless Steel
- K** Cast Iron
- N** Non-ferrous
- S** Exotic Materials
- H** Hardened Steel

- USA Stocked Item
- ★ Worldwide Warehouse Item
- ▲ USA Limited Availability Item
- In stock by 1st Quarter 2017

Negative Inserts

C

D

R

S



T

V

W

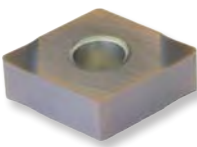
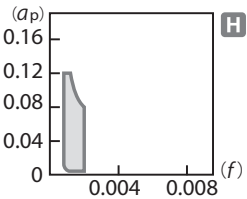
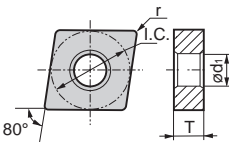
Swiss Tooling

CNGG EGH		Rake Angle: 4° 	Cutting Conditions:				Coated	Cermet		Uncoated		
			Continuous Cut	Medium Cut	Interrupted Cut	●	●	●	●	●		
					AC503U							
Sumitomo Catalog #	ISO Catalog #	I.C.	T	r								ød1
CNGG430.5EGH	CNGG120402N-GH	.500	.1875	.0078								.2031
CNGG431EGH	CNGG120404N-GH			.0156								
CNGG432EGH	CNGG120408N-GH			.0313								

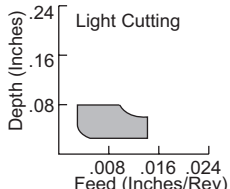
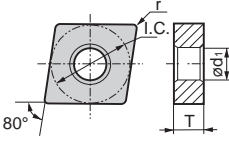
CNGG ESU		Rake Angle: 13° 	Cutting Conditions:				Coated	Cermet		Uncoated		
			Continuous Cut	Medium Cut	Interrupted Cut	●	●	●	●	●		
					AC510U AC520U							
Sumitomo Catalog #	ISO Catalog #	I.C.	T	r								ød1
CNGG430.5ESU	CNGG120401N-SU	.500	.1875	.0039								.2031
CNGG430.5ESU	CNGG120402N-SU			.0078								
CNGG431ESUJ	CNGG120404N-SUJ			.0156								
CNGG431ESU	CNGG120404N-SU	.0156		.0313								
CNGG432ESUJ	CNGG120408N-SUJ	.0313		.0313								
CNGG432ESU	CNGG120408N-SU	.0313		.0313								

J in ESUJ = J Polish

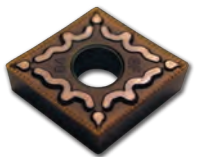
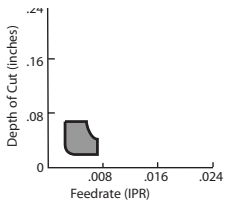
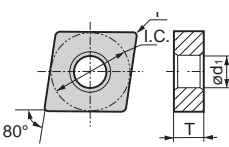
CNGG EEF		Rake Angle: 20° 	Cutting Conditions:				Coated	Cermet		Uncoated	
			Continuous Cut	Medium Cut	Interrupted Cut	●	●	●	●	●	
					AC510U AC520U						
Sumitomo Catalog #	ISO Catalog #	I.C.	T	r							
CNGG431EEF	CNGG1240404N-EF	.500	.1875	.0156	.2031						



CN 80° Diamond Type
Negative
With Insert Hole

- P** Steel
- M** Stainless Steel
- K** Cast Iron
- N** Non-ferrous
- S** Exotic Materials
- H** Hardened Steel

- USA Stocked Item
- ★ Worldwide Warehouse Item
- ▲ USA Limited Availability Item
- In stock by 1st Quarter 2017

CNMG		Rake Angle: 20°	Cutting Conditions:				Coated	Cermet			Uncoated				
EFA			Continuous Cut					●	●	●	●				
			Medium Cut					●	●	●	●				
			Interrupted Cut						●	●	●				
		<p>Depth (Inches)</p> <p>Feed (Inches/Rev)</p>						T1500Z	T2000Z	T3000Z	T1500A	T1200A			
Sumitomo Catalog #	ISO Catalog #	I.C.	T	r	ød1										
CNMG430.5EFA	CNMG120402N-FA	.500	.1875	.0078	.2031		●	●	●	●	▲				
CNMG431EFA	CNMG120404N-FA			.0156			●	●	●	●	▲				
CNMG432EFA	CNMG120408N-FA			.0313			●	●	★	●	▲				

CNMG		Rake Angle: 10°	Cutting Conditions:				Coated	Cermet			Uncoated					
EFL			Continuous Cut				●	●	●	●	●					
			Medium Cut				●	●	●	●	●	●				
			Interrupted Cut				●	●	●	●						
		<p>Depth of Cut (Inches)</p> <p>Feed (IPR)</p>						AC8025P	AC820P	YB100	T1500Z	T2000Z	T3000Z			
Sumitomo Catalog #	ISO Catalog #	I.C.	T	r	ød1											
CNMG431EFL	CNMG120404N-FL	.500	.1875	.0156	.2031		●	●	●	●	●	★				
CNMG432EFL	CNMG120408N-FL			.0313			●	●	●	●	●	★				

CNMG		Rake Angle: 10°	Cutting Conditions:				Coated	Cermet			Uncoated					
EFP			Continuous Cut						●							
			Medium Cut						●							
			Interrupted Cut						●							
		<p>Depth (Inches)</p> <p>Feed (Inches/Rev)</p>									T1200A					
Sumitomo Catalog #	ISO Catalog #	I.C.	T	r	ød1											
CNMG430.5EFP	CNMG120402N-FP	.500	.1875	.0078	.2031					▲						
CNMG431EFP	CNMG120404N-FP			.0156						▲						
CNMG432EFP	CNMG120408N-FP			.0313						▲						

Negative Inserts

C

D

R

S

T

V

W

Swiss Tooling



80° DIAMOND TYPE

NEGATIVE INSERT

Indexable Inserts for Turning

CN

80° Diamond Type

Negative

With Insert Hole

- P** Steel
- M** Stainless Steel
- K** Cast Iron
- N** Non-ferrous
- S** Exotic Materials
- H** Hardened Steel

- USA Stocked Item
- ★ Worldwide Warehouse Item
- ▲ USA Limited Availability Item
- In stock by 1st Quarter 2017

CNMG ESU

Rake Angle: 13°



Cutting Conditions:

Continuous Cut

Medium Cut

Interrupted Cut

Coated

Cermet

UC

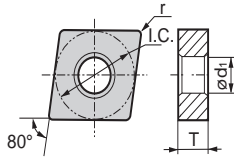
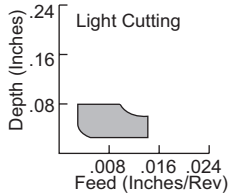

Material	AC810P	AC820P	AC830P	AC700G	YB100	ACG10M	ACG030M	ACG040M	ACG30M	AC530U	AC510U	AC520U	T1500Z	T2000Z	T3000Z	T1500A	T1200A	EH510	
Continuous Cut	●	●	●	●	●	●	●	●	●	●	●	●	●	●	●	●	●	●	●
Medium Cut	●	●	●	●	●	●	●	●	●	●	●	●	●	●	●	●	●	●	●
Interrupted Cut	●	●	●	●	●	●	●	●	●	●	●	●	●	●	●	●	●	●	●

Sumitomo Catalog #	ISO Catalog #	I.C.	T	r	ød1
CNMG321ESU	CNMG090304N-SU	.375	.125	.0156	.150
CNMG322ESU	CNMG090308N-SU			.0313	
CNMG331ESU	CNMG090404N-SU			.0156	
CNMG332ESU	CNMG090408N-SU			.0313	
CNMG430.5ESU	CNMG120402N-SU	.500	.1875	.0078	.2031
CNMG431ESU	CNMG120404N-SU			.0156	
CNMG432ESU	CNMG120408N-SU			.0313	
CNMG433ESU	CNMG120412N-SU			.0469	

CNMG ESE

Rake Angle: 5°



Cutting Conditions:

Continuous Cut

Medium Cut

Interrupted Cut

Coated

Cermet

Uncoated

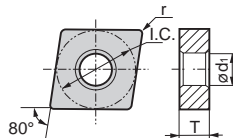
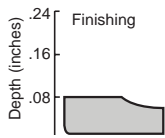

Material	AC810P	AC8205P	AC820P	AC830P	T1500A
Continuous Cut	●	●	●	●	●
Medium Cut	●	●	●	●	●
Interrupted Cut	●	●	●	●	●

Sumitomo Catalog #	ISO Catalog #	I.C.	T	r	ød1
CNMG431ESE	CNMG120404N-SE	.500	.1875	.0156	.2031
CNMG432ESE	CNMG120408N-SE			.0313	
CNMG433ESE	CNMG120412N-SE			.0469	





Negative Inserts
 C
 D
 R
 S
 T
 V
 W
 Swiss Tooling

CN 80° Diamond Type
Negative
With Insert Hole

- P** Steel
- M** Stainless Steel
- K** Cast Iron
- N** Non-ferrous
- S** Exotic Materials
- H** Hardened Steel

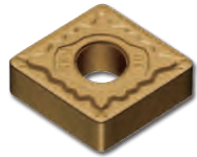
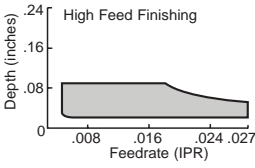
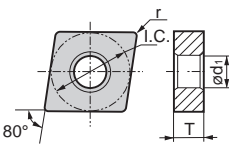
- USA Stocked Item
- ★ Worldwide Warehouse Item
- ▲ USA Limited Availability Item
- In stock by 1st Quarter 2017

CNMG ESEW Wiper Insert		Rake Angle: 5° 	Cutting Conditions:						Coated		Cermet		Uncoated			
			Continuous Cut	Medium Cut	Interrupted Cut	●	●	●	●	●	●	●	●			
							AC805P	AC810P	AC8025P	AC820P	T1500A					
Sumitomo Catalog #	ISO Catalog #	I.C.	T	r	ød1											
CNMG431ESEW	CNMG120404N-SEW	.500	.1875	.0156	.2031	●	●	●	●	●						
CNMG432ESEW	CNMG120408N-SEW			.0313		●	●	●	●	●						
CNMG433ESEW	CNMG120412N-SEW			.0469		●	●	●	●	●						

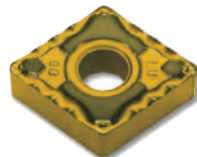
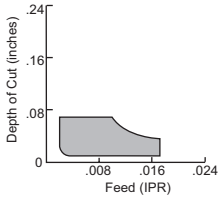
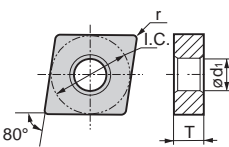
CNMG ELU		Rake Angle: 10° 	Cutting Conditions:						Coated		Cermet		Uncoated			
			Continuous Cut	Medium Cut	Interrupted Cut	●	●	●	●	●	●	●	●			
							AC810P	AC8025P	AC820P	AC700G	YB100	T1500Z	T2000Z	T3000Z	T1500A	T1200A
Sumitomo Catalog #	ISO Catalog #	I.C.	T	r	ød1											
CNMG321ELU	CNMG090304N-LU	.375	.125	.0156	.150	●	●	●	●	●	●	●	●	●	●	●
CNMG322ELU	CNMG090308N-LU			.0313		●	●	●	●	●	●	●	●	●	●	●
CNMG431ELU	CNMG120404N-LU			.0156		●	●	●	●	●	●	●	●	●	●	●
CNMG432ELU	CNMG120408N-LU	.500	.1875	.0313	.2031	●	●	●	●	●	●	●	●	●	●	●
CNMG433ELU	CNMG120412N-LU			.0469		●	●	●	●	●	●	●	●	●	●	●

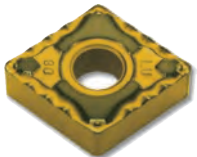
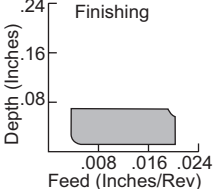
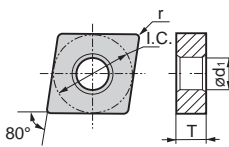
CNMG ELUW Wiper Insert		Rake Angle: 10° 	Cutting Conditions:						Coated		Cermet		Uncoated			
			Continuous Cut	Medium Cut	Interrupted Cut	●	●	●	●	●	●	●				
							AC810P	AC8025P	AC820P	AC700G	YB100	T1500Z	T2000Z	T3000Z		
Sumitomo Catalog #	ISO Catalog #	I.C.	T	r	ød1											
CNMG431ELUW	CNMG120404N-LUW	.500	.1875	.0156	.2031	●	●	●	●	●	●	●	●	●	●	●
CNMG432ELUW	CNMG120408N-LUW			.0313		●	●	●	●	●	●	●	●	●	●	●
CNMG433ELUW	CNMG120412N-LUW			.0469		●	●	●	●	●	●	●	●	●	●	●

Negative Inserts

C

D

R

S

T

V

W

Swiss Tooling



80° DIAMOND TYPE

NEGATIVE INSERT

Indexable Inserts for Turning

CN

80° Diamond Type

Negative

With Insert Hole

- P** Steel
- M** Stainless Steel
- K** Cast Iron
- N** Non-ferrous
- S** Exotic Materials
- H** Hardened Steel

- USA Stocked Item
- ★ Worldwide Warehouse Item
- ▲ USA Limited Availability Item
- In stock by 1st Quarter 2017

Negative Inserts

C

D

R

S

T

V

W

Swiss Tooling

CNMG ENK		Rake Angle: 10° 	Cutting Conditions:				Coated		Cermet		Uncoated	
			Continuous Cut	Medium Cut	Interrupted Cut	●	●	●	●	●	●	
					AC820P		T1200A					
Sumitomo Catalog #	ISO Catalog #	I.C.	T	r	ød1							
CNMG431ENK	CNMG120404N-SK	.500	.1875	.0156	.2031							
CNMG432ENK	CNMG120408N-SK			.0313								

CNMG FNJ		Rake Angle: 0° 	Cutting Conditions:				Coated		Cermet		Uncoated	
			Continuous Cut	Medium Cut	Interrupted Cut							
									G10E			
Sumitomo Catalog #	ISO Catalog #	I.C.	T	r	ød1							
CNMG431FNJ	CNMG120404N-UJ	.500	.1875	.0156	.2031							

CNMG EEF		Rake Angle: 20° 	Cutting Conditions:				Coated		Cermet		Uncoated		
			Continuous Cut	Medium Cut	Interrupted Cut	●	●	●	●	●	●		
					AC6020M		AC6030M		AC6040M		AC630M		
Sumitomo Catalog #	ISO Catalog #	I.C.	T	r	ød1					EH510		EH520	
CNMG331EEF	CNMG090404N-EF	.375		.0156	.150								
CNMG332EEF	CNMG090408N-EF			.0313									
CNMG431EEF	CNMG120404N-EF		.1875	.0156		AC510U		AC520U					
CNMG432EEF	CNMG120408N-EF	.500		.0313	.2031								
CNMG433EEF	CNMG120412N-EF			.0469									



CN

80° Diamond Type

Negative

With Insert Hole

- P** Steel
- M** Stainless Steel
- K** Cast Iron
- N** Non-ferrous
- S** Exotic Materials
- H** Hardened Steel

- USA Stocked Item
- ★ Worldwide Warehouse Item
- ▲ USA Limited Availability Item
- In stock by 1st Quarter 2017

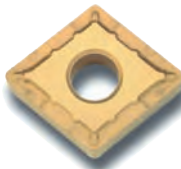
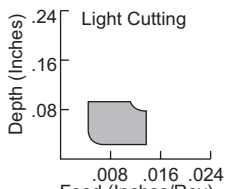
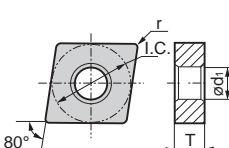
CNMG ESX		Rake Angle: 3°	Cutting Conditions:				Coated		Cermet		Uncoated						
			Continuous Cut	Medium Cut	Interrupted Cut	●	●	●	●								
							AC810P	AC8025P	AC820P	AC830P	AC700G	T1500Z	T2000Z	T3000Z	T1500A	T1200A	
							●	●	●	●	●	●	●	●	●	●	●
Sumitomo Catalog #	ISO Catalog #	I.C.	T	r	ød1	●	●	●	●	●	●	●	●	●	●		
CNMG431ESX	CNMG120404N-SX	.500	.1875	.0156	.2031	●	●	●	●	●	●	●	●	●	●		
CNMG432ESX	CNMG120408N-SX			.0313		●	●	●	●	●	●	●	●	●	●	●	●
CNMG433ESX	CNMG120412N-SX			.0469		●	●	●	●	●	●	●	●	●	●	●	●

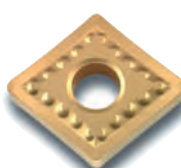
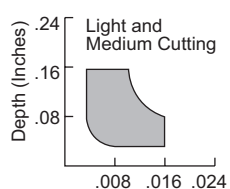
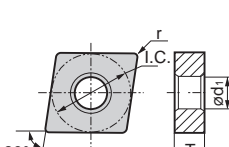
CNMG EUP		Rake Angle: 10°	Cutting Conditions:				Coated		Cermet		Uncoated								
			Continuous Cut	Medium Cut	Interrupted Cut	●	●	●	●	●	●								
							AC8025P	AC820P	AC830P	AC6030M	AC6040M	AC610M	AC630M	AC530U	AC510U	AC520U	G10E	EH510	
							●	●	●	●	●	●	●	●	●	●	●	●	●
Sumitomo Catalog #	ISO Catalog #	I.C.	T	r	ød1	●	●	●	●	●	●	●	●	●	●	●	●		
CNMG431EUP	CNMG120404N-UP	.500	.1875	.0156	.2031	●	●	●	●	●	●	●	●	●	●	●	●		
CNMG432EUP	CNMG120408N-UP			.0313		●	●	●	●	●	●	●	●	●	●	●	●	●	●
CNMG433EUP	CNMG120412N-UP			.0469		●	●	●	●	●	●	●	●	●	●	●	●	●	●
CNMG542EUP	CNMG160608N-UP	.625	.250	.0313	.250	●	●	●	●	●	●	●	●	●	●	●	●		
CNMG543EUP	CNMG160612N-UP			.0469		●	●	●	●	●	●	●	●	●	●	●	●	●	●
CNMG643EUP	CNMG190612N-UP			.0469		●	●	●	●	●	●	●	●	●	●	●	●	●	●

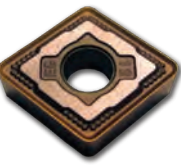
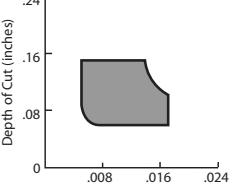
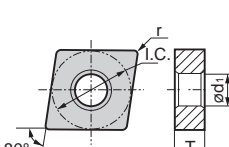
CNMG EEG		Rake Angle: 0°	Cutting Conditions:				Coated		Cermet		Uncoated					
			Continuous Cut	Medium Cut	Interrupted Cut	●	●	●	●	●	●					
							AC8025P	AC6020M	AC6030M	AC6040M	AC610M	AC630M	AC510U	AC520U	EH510	EH520
							●	●	●	●	●	●	●	●	●	●
Sumitomo Catalog #	ISO Catalog #	I.C.	T	r	ød1	●	●	●	●	●	●	●	●	●	●	
CNMG332EEG	CNMG090408N-EG	.375	.1875	.0313	.150	●	●	●	●	●	●	●	●	●	●	
CNMG333EEG	CNMG090412N-EG			.0469		●	●	●	●	●	●	●	●	●	●	●
CNMG431EEG	CNMG120404N-EG			.0156		●	●	●	●	●	●	●	●	●	●	●
CNMG432EEG	CNMG120408N-EG	.500	.1875	.0313	.2031	●	●	●	●	●	●	●	●	●	●	
CNMG433EEG	CNMG120412N-EG			.0469		●	●	●	●	●	●	●	●	●	●	●
CNMG543EEG	CNMG160612N-EG			.0469		●	●	●	●	●	●	●	●	●	●	●
CNMG544EEG	CNMG160616N-EG	.625	.250	.0625	.250	●	●	●	●	●	●	●	●	●	●	
CNMG643EEG	CNMG190612N-EG			.0469		●	●	●	●	●	●	●	●	●	●	●
CNMG644EEG	CNMG190616N-EG			.0625		●	●	●	●	●	●	●	●	●	●	●

Negative Inserts

C

D

R

S

T

V

W

Swiss Tooling

80° DIAMOND TYPE

NEGATIVE INSERT

Indexable Inserts for Turning

CN

80° Diamond Type

Negative

With Insert Hole

- P** Steel
- M** Stainless Steel
- K** Cast Iron
- N** Non-ferrous
- S** Exotic Materials
- H** Hardened Steel

- USA Stocked Item
- ★ Worldwide Warehouse Item
- ▲ USA Limited Availability Item
- In stock by 1st Quarter 2017

Negative Inserts

C

D

R

S

T

V

W

Swiss Tooling

CNMG EEX		Rake Angle: 16°	Cutting Conditions:					Coated			Uncoated			
			Continuous Cut	Medium Cut	Interrupted Cut	AC6020M	AC6030M	AC6040M	AC610M	AC630M	AC530U	AC510U	AC520U	EH510
Sumitomo Catalog #		ISO Catalog #	I.C.	T	r	ød1								
CNMG431EEX		CNMG120404N-EX			.0156		●	●	●	●	●	●		
CNMG432EEX		CNMG120408N-EX	.500	.1875	.0313	.2031	●	●	●	●	●	●	●	
CNMG433EEX		CNMG120412N-EX			.0469		○	●	●	●	●	●		
CNMG543EEX		CNMG160612N-EX	.625		.0469	.250		●						
CNMG643EEX		CNMG190612N-EX	.750	.250	.0469	.3126								

CNMG EGU		Rake Angle: 7°	Cutting Conditions:					Coated						Cermets				
			Continuous Cut	Medium Cut	Interrupted Cut	AC810P	AC8025P	AC820P	AC830P	AC700G	YB100	AC610M	AC6020M	AC6030M	AC6040M	AC630M	AC530U	T1500A
Sumitomo Catalog #		ISO Catalog #	I.C.	T	r	ød1												
CNMG322EGU		CNMG090308N-GU	.375	.125	.0313	.150	●	●	●	●	●	●	●	●	●	●		
CNMG431EGU		CNMG120404N-GU			.0156		●	●	★	★								
CNMG432EGU		CNMG120408N-GU	.500	.1875	.0313	.2031	●	●	●	●	●	●	●	●	●	●	●	
CNMG433EGU		CNMG120412N-GU			.0469		●	●	●	●	●	●	●	●	●	●		
CNMG434EGU		CNMG120416N-GU			.0625		●	●	●	●	●	●	●	●	●	●	●	
CNMG542EGU		CNMG160608N-GU			.0313		★	●	●	●	●	●	●	●	●	●	●	
CNMG543EGU		CNMG160612N-GU	.625	.250	.0469	.250	●	●	●	●	●	●	●	●	●	●	●	
CNMG544EGU		CNMG160616N-GU			.0625		●	●	●	●	●	●	●	●	●	●	●	

CNMG EGUW Wiper Insert		Rake Angle: 0°	Cutting Conditions:					Coated						Cermets			
			Continuous Cut	Medium Cut	Interrupted Cut	AC810P	AC8025P	AC820P	AC830P	AC700G	YB100	AC6030M	AC630M	AC405K	AC410K	AC415K	
Sumitomo Catalog #		ISO Catalog #	I.C.	T	r	ød1											
CNMG432EGUW		CNMG120408N-GUW	.500	.1875	.0313	.2031	●	●	●	●	●	●	●	●	●	●	
CNMG433EGUW		CNMG120412N-GUW			.0469		●	●	●	●	●	●	●	●	●	●	
CNMG543EGUW		CNMG160612N-GUW	.625	.250	.0469	.250	●	●	●	●	●	●	●	●	●	●	



CN 80° Diamond Type
Negative
With Insert Hole

- P** Steel
- M** Stainless Steel
- K** Cast Iron
- N** Non-ferrous
- S** Exotic Materials
- H** Hardened Steel

- USA Stocked Item
- ★ Worldwide Warehouse Item
- ▲ USA Limited Availability Item
- In stock by 1st Quarter 2017

CNMG EGE		Rake Angle: 3°	Cutting Conditions:				Coated					Cermet			Uncoated			
							Continuous Cut	Medium Cut	Interrupted Cut	●	●	●	●	●	●	●	●	●
Sumitomo Catalog #	ISO Catalog #	I.C.	T	r	ød1	AC805P	AC810P	AC8025P	AC820P	AC830P	AC700G							
CNMG431EGE	CNMG120404N-GE			.0156		●	★	●	●	●	●							
CNMG432EGE	CNMG120408N-GE	.500	.1875	.0313	.2031	●	●	●	●	●	●							
CNMG433EGE	CNMG120412N-GE			.0469		●	●	●	●	●	●							
CNMG434EGE	CNMG120416N-GE			.0625		●	★	●	●	●	●							
CNMG543EGE	CNMG160612N-GE	.625	.250	.0469	.250	●	●	●	●	●	●							
CNMG544EGE	CNMG160616N-GE			.0625		●	●	●	●	●	●							
CNMG643EGE	CNMG190612N-GE	.750		.0469	.3126	●	●	●	●	●	●							
CNMG644EGE	CNMG190616N-GE			.0625		●	●	●	●	●	●							

CNMG EUX		Rake Angle: 0°	Cutting Conditions:				Coated					Cermet						
							Continuous Cut	Medium Cut	Interrupted Cut	●	●	●	●	●	●	●	●	●
Sumitomo Catalog #	ISO Catalog #	I.C.	T	r	ød1	AC810P	AC8025P	AC820P	AC830P	AC700G	YB100	AC410K						
CNMG322EUX	CNMG090308N-UX	.375	.125	.0313	.150	●	●	●	●	●	●	●						
CNMG431EUX	CNMG120404N-UX			.0156		●	●	●	●	●	●	●						
CNMG432EUX	CNMG120408N-UX	.500	.1875	.0313	.2031	●	●	●	●	●	●	●						
CNMG433EUX	CNMG120412N-UX			.0469		●	●	●	●	●	●	●						
CNMG434EUX	CNMG120416N-UX			.0625		●	●	●	●	●	●	●						
CNMG542EUX	CNMG160608N-UX			.0313		●	●	●	●	●	★	●						
CNMG543EUX	CNMG160612N-UX	.625	.250	.0469	.250	●	●	●	●	●	●	●						
CNMG544EUX	CNMG160616N-UX			.0625		●	●	●	●	●	●	●						
CNMG642EUX	CNMG190608N-UX			.0313		●	●	●	●	●	●	▲						
CNMG643EUX	CNMG190612N-UX	.750	.250	.0469	.3126	●	●	●	●	●	●	●						
CNMG644EUX	CNMG190616N-UX			.0625		●	●	●	●	●	●	●						



80° DIAMOND TYPE

NEGATIVE INSERT

Indexable Inserts for Turning

CN

80° Diamond Type

Negative

With Insert Hole

- P** Steel
- M** Stainless Steel
- K** Cast Iron
- N** Non-ferrous
- S** Exotic Materials
- H** Hardened Steel

- USA Stocked Item
- ★ Worldwide Warehouse Item
- ▲ USA Limited Availability Item
- In stock by 1st Quarter 2017

Negative Inserts

C

D

R

S

T

V

W

Swiss Tooling

CNMG ENG

Rake Angle: 4°



Cutting Conditions:

Continuous Cut

Medium Cut

Interrupted Cut

Coated

Cermet

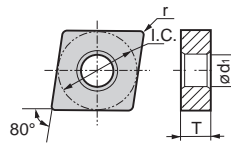
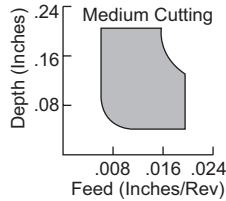
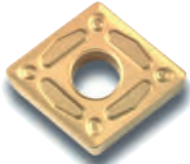

AC8025P

AC820P

AC830P

AC700G

T1200A

Sumitomo Catalog #

ISO Catalog #

I.C.

T

r

ød1

AC8025P

AC820P

AC830P

AC700G

T1200A

Sumitomo Catalog #	ISO Catalog #	I.C.	T	r	ød1	AC8025P	AC820P	AC830P	AC700G	T1200A
CNMG321ENG	CNMG090304N-UG	.375	.125	.0156	.150	●	★			
CNMG322ENG	CNMG090308N-UG			.0313		●				
CNMG431ENG	CNMG120404N-UG			.0156		●	●	●	●	
CNMG432ENG	CNMG120408N-UG			.0313		●	●	●	●	
CNMG433ENG	CNMG120412N-UG	.500	.1875	.0469	.2031	●	●	●	●	▲
CNMG434ENG	CNMG120416N-UG			.0625		●	★	★		
CNMG542ENG	CNMG160608N-UG			.0313		●	●	●		
CNMG543ENG	CNMG160612N-UG	.625	.250	.0469	.250	●	●	●		
CNMG544ENG	CNMG160616N-UG			.0625		●	●	★		
CNMG642ENG	CNMG190608N-UG			.0313		●	●	●		
CNMG643ENG	CNMG190612N-UG	.750	.250	.0469	.3126	●	●	●		
CNMG644ENG	CNMG190616N-UG			.0625		●	●	★		

CNMG FNZ/ENZ

Rake Angle: 4°

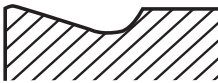

Cutting Conditions:

Continuous Cut

Medium Cut

Interrupted Cut

Coated

Uncoated

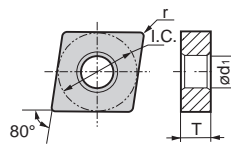
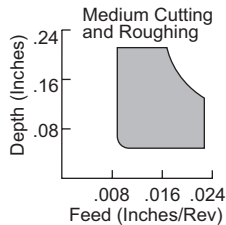
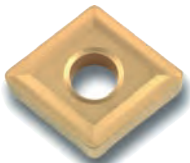

AC8025P

AC820P

AC830P

AC700G

AC405K

AC410K

AC415K

AC420K

G10E

Sumitomo Catalog #

ISO Catalog #

I.C.

T

r

ød1

AC8025P

AC820P

AC830P

AC700G

AC405K

AC410K

AC415K

AC420K

G10E

Sumitomo Catalog #	ISO Catalog #	I.C.	T	r	ød1	AC8025P	AC820P	AC830P	AC700G	AC405K	AC410K	AC415K	AC420K	G10E
CNMG431ENZ	CNMG120404N-UZ			.0156		●	●	●	●	●	●	●	●	
CNMG432ENZ	CNMG120408N-UZ			.0313		●	●	●	●	●	▲	●	●	
CNMG433ENZ	CNMG120412N-UZ	.500	.1875	.0469	.2031	●	●	●	●	●	▲	●	●	
CNMG434ENZ	CNMG120416N-UZ			.0625		●	●	●	●	●	●	●	●	
CNMG542ENZ	CNMG160608N-UZ			.0313		●	●	●	●	●	●	●	●	
CNMG543ENZ	CNMG160612N-UZ	.625	.250	.0469	.250	●	●	●	●	●	●	●	●	
CNMG544ENZ	CNMG160616N-UZ			.0625		●	●	●	●	●	▲	●	●	
CNMG642ENZ	CNMG190608N-UZ			.0313		●	●	●	●	●	●	●	●	
CNMG643ENZ	CNMG190612N-UZ	.750	.250	.0469	.3126	●	●	●	●	●	●	●	●	
CNMG644ENZ	CNMG190616N-UZ			.0625		●	●	★	●	●	●	●	●	
CNMG432FNU	CNMG120408N-NU			.0313		●	●	●	●	●	●	●	●	●
CNMG432FNZ	CNMG120408N-UZ	.500	.1875	.0313	.2031	●	●	●	●	●	●	●	●	●



CN 80° Diamond Type
Negative
With Insert Hole

- P** Steel
- M** Stainless Steel
- K** Cast Iron
- N** Non-ferrous
- S** Exotic Materials
- H** Hardened Steel

- USA Stocked Item
- ★ Worldwide Warehouse Item
- ▲ USA Limited Availability Item
- In stock by 1st Quarter 2017

CNMG EEM		Rake Angle: 0°		Cutting Conditions:							Coated						Uncoated					
				Continuous Cut							Medium Cut						Interrupted Cut					
		 Depth (Inches) vs Feed (Inches/Rev)																				
Sumitomo Catalog #	ISO Catalog #	I.C.	T	r	ød1	AC8025P	AC6020M	AC6030M	AC6040M	AC510U	AC520U											
CNMG432EEM	CNMG120408N-EM	.500	.1875	.0313	.2031	●	●	●	●	●	●											
CNMG433EEM	CNMG120412N-EM					○	○	○	○	○	○	○	○	○								
CNMG434EEM	CNMG120416N-EM					○	○	○	○	○	○	○	○	○								
CNMG542EEM	CNMG160608N-EM	.625	.250	.0313	.250	●	●	●	●	●	●											
CNMG543EEM	CNMG160612N-EM					○	○	○	○	○	○	○	○	○								
CNMG544EEM	CNMG160616N-EM					○	○	○	○	○	○	○	○	○								
CNMG643EEM	CNMG190612N-EM	.750	.250	.0469	.3126	●	○	○	○	○	○											
CNMG644EEM	CNMG190616N-EM					○	○	○	○	○	○	○	○	○								
CNMG646EEM	CNMG190624N-EM					○	○	○	○	○	○	○	○	○								
CNMG866EEM	CNMG250724N-EM	1.000	.3125	.0938	.3622	●	○	○	○	○	○											

CNMG EMU		Rake Angle: 4°		Cutting Conditions:							Coated						Uncoated								
				Continuous Cut							Medium Cut						Interrupted Cut								
		 Depth (Inches) vs Feed (Inches/Rev)																							
Sumitomo Catalog #	ISO Catalog #	I.C.	T	r	ød1	AC810P	AC8025P	AC820P	AC830P	AC700G	YB100	AC610M	AC6030M	AC6040M	AC630M	AC530U	AC410K	AC510U	AC520U	EH510	EH520				
CNMG432EMU	CNMG120408N-MU	.500	.1875	.0313	.2031	●	●	●	●	●	●	●	●	●	●	●	●	●	●	●	●	●			
CNMG433EMU	CNMG120412N-MU					○	○	○	○	○	○	○	○	○	○	○	○	○	○	○	○	○	○	○	○
CNMG434EMU	CNMG120416N-MU					○	○	○	○	○	○	○	○	○	○	○	○	○	○	○	○	○	○	○	○
CNMG542EMU	CNMG160608N-MU	.625	.250	.0313	.250	●	●	●	●	●	●	●	●	●	●	●	●	●	●	●	●	●			
CNMG543EMU	CNMG160612N-MU					○	○	○	○	○	○	○	○	○	○	○	○	○	○	○	○	○	○	○	○
CNMG544EMU	CNMG160616N-MU					○	○	○	○	○	○	○	○	○	○	○	○	○	○	○	○	○	○	○	○
CNMG642EMU	CNMG190608N-MU	.750	.250	.0313	.3126	●	○	○	○	○	○	○	○	○	○	○	○	○	○	○	○	○	○		
CNMG643EMU	CNMG190612N-MU					○	○	○	○	○	○	○	○	○	○	○	○	○	○	○	○	○	○	○	○
CNMG644EMU	CNMG190616N-MU					○	○	○	○	○	○	○	○	○	○	○	○	○	○	○	○	○	○	○	○
CNMG866EMU	CNMG250924N-MU	1.000	.3125	.0938	.3622	●	○	○	○	○	○	○	○	○	○	○	○	○	○	○	○	○			

Negative Inserts

C

D

R

S

T

V

W

Swiss Tooling



80° DIAMOND TYPE

NEGATIVE INSERT

Indexable Inserts for Turning

CN

80° Diamond Type

Negative

With Insert Hole

- P** Steel
- M** Stainless Steel
- K** Cast Iron
- N** Non-ferrous
- S** Exotic Materials
- H** Hardened Steel

- USA Stocked Item
- ★ Worldwide Warehouse Item
- ▲ USA Limited Availability Item
- In stock by 1st Quarter 2017

Negative Inserts

C

D

R

S

T

V

W

Swiss Tooling

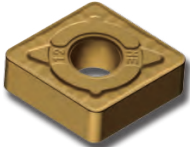
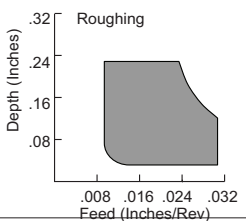
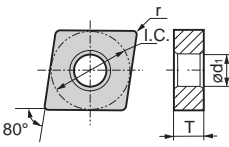
CNMG EME		Rake Angle: 4° 	Cutting Conditions:					Coated					Uncoated							
			Continuous Cut	Medium Cut	Interrupted Cut	●	●	●	●	●	●	●	●	●	●	●	●			
								AC805P	AC810P	AC8025P	AC820P	AC830P								
Sumitomo Catalog #	ISO Catalog #	I.C.	T	r	ød1															
CNMG432EME	CNMG120408N-ME			.0313																
CNMG433EME	CNMG120412N-ME	.500	.1875	.0469	.2031	●	●	●	●	●										
CNMG434EME	CNMG120416N-ME			.0625		●	●	●	●	●										
CNMG542EME	CNMG160608N-ME			.0313																
CNMG543EME	CNMG160612N-ME	.625		.0469	.250	●	●	●	●	●										
CNMG544EME	CNMG160616N-ME		.250	.0625		●	●	●	●	●										
CNMG643EME	CNMG190612N-ME			.0469	.3126	●	●	●	●	●										
CNMG644EME	CNMG190616N-ME	.750		.0625		●	●	●	●	●										
CNMG866EME	CNMG250924N-ME	1.000	.3125	.0938	.3622	●	●	●	●	●										

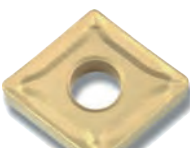
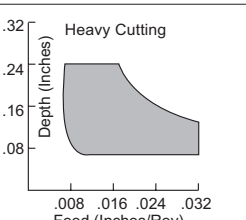
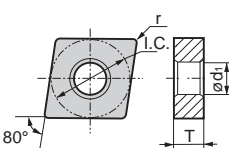
CNMG EMX		Rake Angle: -15° 	Cutting Conditions:					Coated					Uncoated								
			Continuous Cut	Medium Cut	Interrupted Cut	●	●	●	●	●	●	●	●	●	●	●	●				
								AC810P	AC8025P	AC820P	AC830P	YB100									
Sumitomo Catalog #	ISO Catalog #	I.C.	T	r	ød1																
CNMG432EMX	CNMG120408N-MX			.0313																	
CNMG433EMX	CNMG120412N-MX	.500	.1875	.0469	.2031	●	●	●	●	●											
CNMG434EMX	CNMG120416N-MX			.0625		●	●	●	●	●											
CNMG542EMX	CNMG160608N-MX			.0313																	
CNMG543EMX	CNMG160612N-MX	.625		.0469	.250	●	●	●	●	●											
CNMG544EMX	CNMG160616N-MX		.250	.0625		●	●	●	●	●											
CNMG643EMX	CNMG190612N-MX			.0469	.3126	●	●	●	●	●											
CNMG644EMX	CNMG190616N-MX	.750		.0625		●	●	●	●	●											



CN 80° Diamond Type
Negative
With Insert Hole

- P** Steel
- M** Stainless Steel
- K** Cast Iron
- N** Non-ferrous
- S** Exotic Materials
- H** Hardened Steel

- USA Stocked Item
- ★ Worldwide Warehouse Item
- ▲ USA Limited Availability Item
- In stock by 1st Quarter 2017

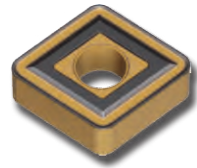
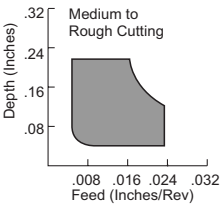
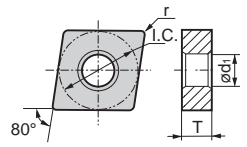
CNMG EGZ		Rake Angle: 0° 	Cutting Conditions:						Coated				Uncoated								
			Continuous Cut	Medium Cut	Interrupted Cut																
							AC405K	AC415K	AC420K												
Sumitomo Catalog #	ISO Catalog #	I.C.	T	r	ød1	AC405K	AC415K	AC420K													
CNMG431EGZ	CNMG120404N-GZ			.0156		●	●	●													
CNMG432EGZ	CNMG120408N-GZ	.500	.1875	.0313	.2031	●	●	●													
CNMG433EGZ	CNMG120412N-GZ			.0469		●	●	●													
CNMG434EGZ	CNMG120416N-GZ			.0625		●	●	●													
CNMG542EGZ	CNMG160608N-GZ			.0313		●	●	●													
CNMG543EGZ	CNMG160612N-GZ	.625	.250	.0469	.250	★	●	●													
CNMG544EGZ	CNMG160616N-GZ			.0625		●	●	●													

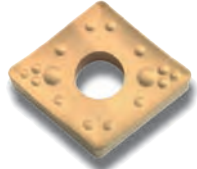
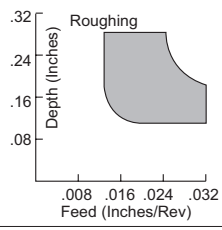
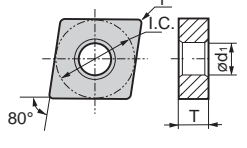
CNMM ENP		Rake Angle: 0° 	Cutting Conditions:						Coated				Uncoated							
			Continuous Cut	Medium Cut	Interrupted Cut															
							AC820P	AC830P												
Sumitomo Catalog #	ISO Catalog #	I.C.	T	r	ød1	AC820P	AC830P													
CNMM646ENP	CNMM190624N-MP	.750	.250	.0938	.3126	★	●													

Negative Inserts

C

D

R

S

T

V

W

Swiss Tooling



80° DIAMOND TYPE

NEGATIVE INSERT

Indexable Inserts for Turning

CN

80° Diamond Type

Negative

With Insert Hole

- P** Steel
- M** Stainless Steel
- K** Cast Iron
- N** Non-ferrous
- S** Exotic Materials
- H** Hardened Steel

- USA Stocked Item
- ★ Worldwide Warehouse Item
- ▲ USA Limited Availability Item
- In stock by 1st Quarter 2017

CNMM EHG

Rake Angle: 0°



Cutting Conditions:

Continuous Cut
Medium Cut
Interrupted Cut

Coated

Cermet

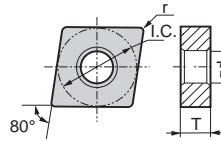
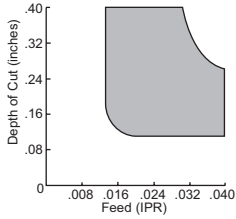

	AC810P	AC8025P	AC820P	AC830P	AC700G														
Continuous Cut	●	●	●	●	●														
Medium Cut	●	●	●	●	●														
Interrupted Cut	●	●	●	●	●														

Sumitomo Catalog #	ISO Catalog #	I.C.	T	r	ød1
CNMM432EHG	CNMM120408N-HG	.500	.1875	.0313	.2031
CNMM433EHG	CNMM120412N-HG			.0469	
CNMM543EHG	CNMM160612N-HG	.625		.0469	.250
CNMM544EHG	CNMM160616N-HG			.0625	
CNMM643EHG	CNMM190612N-HG		.250	.0469	
CNMM644EHG	CNMM190616N-HG	.750		.0625	.3126
CNMM646EHG	CNMM190624N-HG			.0938	

CNMA

No Breaker

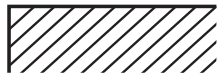

Cutting Conditions:

Continuous Cut
Medium Cut
Interrupted Cut

Coated

Uncoated

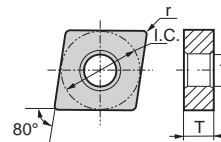

	AC700G	YB100	AC405K	AC410K	AC415K	AC420K													
Continuous Cut	●	●	●	●	●	●													
Medium Cut	●	●	●	●	●	●													
Interrupted Cut	●	●	●	●	●	●													

Sumitomo Catalog #	ISO Catalog #	I.C.	T	r	ød1
CNMA431	CNMA120404			.0156	
CNMA432	CNMA120408			.0313	
CNMA433	CNMA120412	.500	.1875	.0469	.2031
CNMA434	CNMA120416			.0625	
CNMA543	CNMA160612	.625		.0469	.250
CNMA544	CNMA160616			.0625	
CNMA643	CNMA190612		.250	.0469	
CNMA644	CNMA190616	.750		.0625	.3126

Negative Inserts

C

D

R

S

T

V

W

Swiss Tooling



DN

55° Diamond Type

Negative

With Insert Hole

- P Steel
- M Stainless Steel
- K Cast Iron
- N Non-ferrous
- S Exotic Materials
- H Hardened Steel

- USA Stocked Item
- ★ Worldwide Warehouse Item
- ▲ USA Limited Availability Item
- In stock by 1st Quarter 2017

DNGG EGH		Rake Angle: 4°	Cutting Conditions:				Coated			Cermet			Uncoated		
							Continuous Cut ● Medium Cut ● Interrupted Cut ●								
						AC503U									
Sumitomo Catalog #	ISO Catalog #	I.C.	T	r	ød1										
DNGG430.5EGH	DNGG150402N-GH	.500	.1875	.0078	.2031										
DNGG431EGH	DNGG150404N-GH			.0156											
DNGG432EGH	DNGG120408N-GH			.0313											

DNGG ESU		Rake Angle: 13°	Cutting Conditions:				Coated			Cermet			Uncoated		
							Continuous Cut ● Medium Cut ● Interrupted Cut ●								
						AC520U									
Sumitomo Catalog #	ISO Catalog #	I.C.	T	r	ød1										
DNGG430ESU	DNGG150401N-SU	.500	.1875	.0039	.2031										
DNGG430.5ESU	DNGG150402N-SU			.0078											
DNGG430.5ESUJ	DNGG150402N-SUJ			.0078											
DNGG431ESU	DNGG150404N-SU	.500	.1875	.0156	.2031										
DNGG431ESUJ	DNGG150404N-SUJ			.0156											
DNGG432ESU	DNGG150408N-SU			.0313											
DNGG432ESUJ	DNGG150408N-SUJ	.0313													

J in ESUJ = J Polish

DNJG UM		Rake Angle: 14°	Cutting Conditions:				Coated			Cermet			Uncoated		
							Continuous Cut ● Medium Cut ● Interrupted Cut ●								
						AC520U									
Sumitomo Catalog #	ISO Catalog #	I.C.	T	r	ød1										
DNJG431L	DNGG150404L-UM	.500	.1875	.0156	.2031										
DNJG431R	DNGG150404R-UM			.0156											
DNJG432L	DNGG150408L-UM			.0313											
DNJG432R	DNGG150408R-UM	.0313													



55° DIAMOND TYPE

NEGATIVE INSERT

Indexable Inserts for Turning

DN

55° Diamond Type

Negative

With Insert Hole

- P** Steel
- M** Stainless Steel
- K** Cast Iron
- N** Non-ferrous
- S** Exotic Materials
- H** Hardened Steel

- USA Stocked Item
- ★ Worldwide Warehouse Item
- ▲ USA Limited Availability Item
- In stock by 1st Quarter 2017

Negative Inserts

C

D

R

S

T

V

W

Swiss Tooling

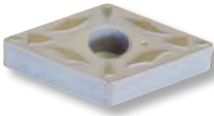
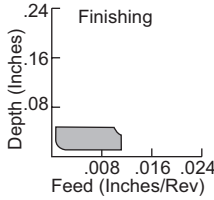
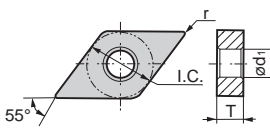
DNMG EFA		Rake Angle: 20°	Cutting Conditions:				Coated		Cermet		Uncoated		
			Continuous Cut	Medium Cut	Interrupted Cut								
													
Sumitomo Catalog #	ISO Catalog #	I.C.	T	r	ød1			T1500Z	T2000Z	T3000Z	T1500A	T1200A	
DNMG431EFA	DNMG150404N-FA	.500	.1875	.0156	.2031			●	●	●	●		
DNMG432EFA	DNMG150408N-FA		.0313			●	●	●	●	●	●		
DNMG441EFA	DNMG150604N-FA		.0156			★	●	●	●	●	●		
DNMG442EFA	DNMG150608N-FA		.250	.0313			●	●	●	●	●	★	

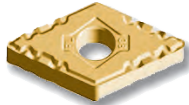
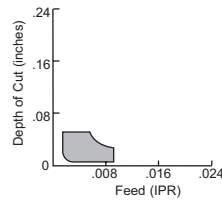
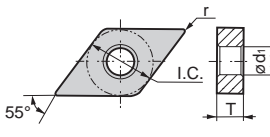
DNMG EFL		Rake Angle: 10°	Cutting Conditions:				Coated		Cermet		Uncoated		
			Continuous Cut	Medium Cut	Interrupted Cut								
													
Sumitomo Catalog #	ISO Catalog #	I.C.	T	r	ød1	AC810P	AC8025P	AC820P	YB100	T1500Z	T2000Z	T3000Z	
DNMG431EFL	DNMG150404N-FL	.500	.1875	.0156	.2031	●	●	●	●	●	●	●	
DNMG432EFL	DNMG150408N-FL		.0313			●	●	●	●	●	●	●	●
DNMG433EFL	DNMG150412N-FL		.0469			●	●	●	●	●	●	●	●

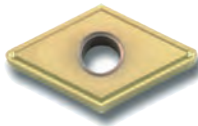
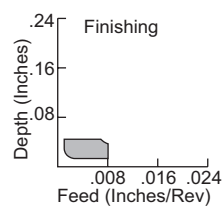
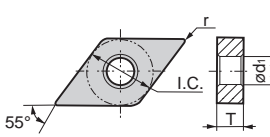
DNMG EFP		Rake Angle: 10°	Cutting Conditions:				Coated		Cermet		Uncoated	
			Continuous Cut	Medium Cut	Interrupted Cut							
												
Sumitomo Catalog #	ISO Catalog #	I.C.	T	r	ød1				T1200A			
DNMG431EFP	DNMG150404N-FP	.500	.1875	.0156	.2031				▲			
DNMG432EFP	DNMG120408N-FP		.0313							▲		



DN

55° Diamond Type

Negative

With Insert Hole

- P** Steel
- M** Stainless Steel
- K** Cast Iron
- N** Non-ferrous
- S** Exotic Materials
- H** Hardened Steel

- USA Stocked Item
- ★ Worldwide Warehouse Item
- ▲ USA Limited Availability Item
- In stock by 1st Quarter 2017

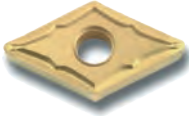
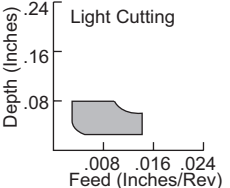
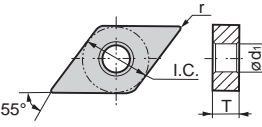
DNMG ESU		Rake Angle: 13°		Cutting Conditions:		Coated										Cermets				UC	
						Continuous Cut	Medium Cut	Interrupted Cut	AC810P	AC8025P	AC820P	AC830P	AC700G	YB100	AC610M	AC6030M	AC6040M	AC630M	AC530J	AC510J	AC520J
																					
Sumitomo Catalog #	ISO Catalog #	I.C.	T	r	ød1																
DNMG331ESU	DNMG090404N-SU	.375	.1875	.0156	.150																
DNMG332ESU	DNMG090408N-SU																				
DNMG333ESU	DNMG090412N-SU																				
DNMG431ESU	DNMG150404N-SU	.500	.2031	.0156	.2031																
DNMG432ESU	DNMG150408N-SU																				
DNMG433ESU	DNMG150412N-SU																				
DNMG441ESU	DNMG150604N-SU																				
DNMG442ESU	DNMG150608N-SU	.250		.0313																	

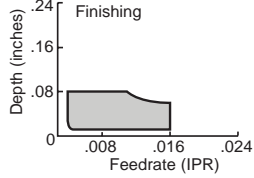
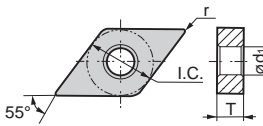
DNMG ESE		Rake Angle: 13°		Cutting Conditions:		Coated				Cermet	Uncoated	
						Continuous Cut	Medium Cut	Interrupted Cut	AC805P	AC810P	AC8025P	AC820P
												
Sumitomo Catalog #	ISO Catalog #	I.C.	T	r	ød1							
DNMG332ESE	DNMG090408N-SE	.375	.1875	.0313	.150							
DNMG431ESE	DNMG150404N-SE											
DNMG432ESE	DNMG150408N-SE	.500	.2031	.0156	.2031							
DNMG433ESE	DNMG150412N-SE											

Negative Inserts

C

D

R

S

T

V

W

Swiss Tooling



55° DIAMOND TYPE

NEGATIVE INSERT

Indexable Inserts for Turning

DN

55° Diamond Type

Negative

With Insert Hole

- P** Steel
- M** Stainless Steel
- K** Cast Iron
- N** Non-ferrous
- S** Exotic Materials
- H** Hardened Steel

- USA Stocked Item
- ★ Worldwide Warehouse Item
- ▲ USA Limited Availability Item
- In stock by 1st Quarter 2017

Negative Inserts

C

D

R

S

T

V

W

Swiss Tooling

DNMX ESEW

Wiper Insert

Rake Angle: 13°



Cutting Conditions:

Continuous Cut

Medium Cut

Interrupted Cut

Coated

Cermet

Uncoated

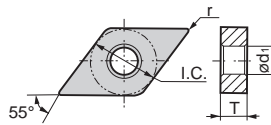
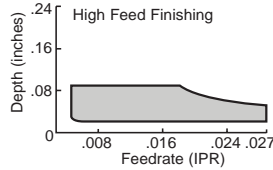
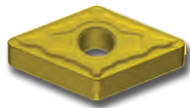

Sumitomo Catalog #	ISO Catalog #	I.C.	T	r	ød1	AC805P	AC810P	AC8025P	AC820P	AC830P	T1500Z	T2000Z	T1500A						
DNMX331ESEW	DNMX110404N-SEW	.375	.1875	.0156	.150	★			★	★									
DNMX332ESEW	DNMX110408N-SEW			.0313		●													
DNMX333ESEW	DNMX110412N-SEW			.0469		★	★												
DNMX431ESEW	DNMX150404N-SEW	.500	.1875	.0156	.2031	●			★	★	●								
DNMX432ESEW	DNMX150408N-SEW			.0313		●	●	●	●	●	●	●	●	●					
DNMX433ESEW	DNMX150412N-SEW			.0469		●	●	●	●	●	●	●	●	●					

DNMG ELU

Rake Angle: 10°



Cutting Conditions:

Continuous Cut

Medium Cut

Interrupted Cut

Coated

Cermet

Uncoated

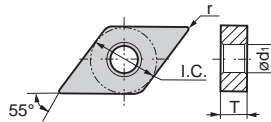
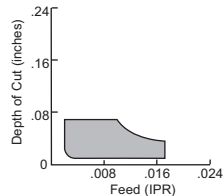
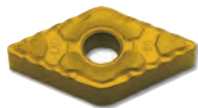

Sumitomo Catalog #	ISO Catalog #	I.C.	T	r	ød1	AC810P	AC8025P	AC820P	AC700G	T1500Z	T2000Z	T3000Z	T1500A	T1200A						
DNMG331ELU	DNMG110404N-LU	.375	.1875	.0156	.150	●														
DNMG332ELU	DNMG110408N-LU			.0313		●									★					
DNMG431ELU	DNMG150404N-LU			.0156		●	●	●	●	●	●	●	●	●	●	●	▲			
DNMG432ELU	DNMG150408N-LU	.500	.1875	.0313	.2031	●	●	●	●	●	●	●	●	●	▲					
DNMG433ELU	DNMG150412N-LU			.0469		●	●	●	●	●	●	●	●	●	●	●	★	▲		



DN

55° Diamond Type

Negative

With Insert Hole

- P Steel
- M Stainless Steel
- K Cast Iron
- N Non-ferrous
- S Exotic Materials
- H Hardened Steel

- USA Stocked Item
- ★ Worldwide Warehouse Item
- ▲ USA Limited Availability Item
- In stock by 1st Quarter 2017

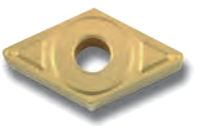
DNMG		Rake Angle: 10°	Cutting Conditions:						Coated			Cermet			Uncoated			
ENK			Continuous Cut						●	●	●	●	●	●	●	●	●	●
		Depth (Inches)	Medium Cut						●	●	●	●	●	●	●	●	●	●
Light Cutting		Feed (Inches/Rev)	Interrupted Cut						●	●	●	●	●	●	●	●	●	●
Sumitomo Catalog #		ISO Catalog #		I.C.	T	r	ød1	AC820P			T1200A							
DNMG431ENK		DNMG150404N-SK		.500	.1875	.0156	.2031	●	●	●	●	●	●	●	●	●	●	●
DNMG432ENK		DNMG150408N-SK				.0313		●	●	●	●	●	●	●	●	●	●	●
DNMG441ENK		DNMG150604N-SK			.250	.0156		●	●	●	●	●	●	●	●	●	●	●
DNMG442ENK		DNMG150608N-SK				.0313		●	●	●	●	●	●	●	●	●	●	●

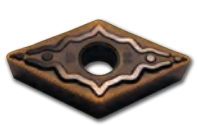
DNMG		Rake Angle: 20°	Cutting Conditions:						Coated			Cermet			Uncoated				
EEF			Continuous Cut						●	●	●	●	●	●	●	●	●		
		Depth of Cut (Inches)	Medium Cut						●	●	●	●	●	●	●	●	●		
Feedrate (IPR)		Feed (Inches/Rev)	Interrupted Cut						●	●	●	●	●	●	●	●	●		
Sumitomo Catalog #		ISO Catalog #		I.C.	T	r	ød1	AC6020M			AC6030M			AC6040M			AC630M		
DNMG331EEF		DNMG110404N-EF		.375		.0156	.150	○	○	○	○	○	○	○	○	○	○	○	
DNMG332EEF		DNMG110408N-EF				.0313		○	○	○	○	○	○	○	○	○	○	○	
DNMG333EEF		DNMG110412N-EF			.1875	.0469		○	○	○	○	○	○	○	○	○	○	○	
DNMG431EEF		DNMG150404N-EF		.500		.0156	.2031	○	○	○	○	○	○	○	○	○	○	○	
DNMG432EEF		DNMG150408N-EF				.0313		○	○	○	○	○	○	○	○	○	○	○	
DNMG433EEF		DNMG150412N-EF				.0469		○	○	○	○	○	○	○	○	○	○	○	

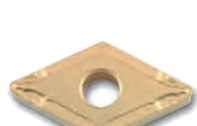
DNMG		Rake Angle: 3°	Cutting Conditions:						Coated			Cermet			Uncoated				
ESX			Continuous Cut						●	●	●	●	●	●	●	●	●		
		Depth (Inches)	Medium Cut						●	●	●	●	●	●	●	●	●		
Feed (Inches/Rev)		Feed (Inches/Rev)	Interrupted Cut						●	●	●	●	●	●	●	●	●		
Sumitomo Catalog #		ISO Catalog #		I.C.	T	r	ød1	AC810P			AC820P			AC830P			AC700G		
DNMG431 ESX		DNMG150404N-SX		.500	.1875	.0156	.2031	●	●	●	●	●	●	●	●	●	●	●	
DNMG432 ESX		DNMG150408N-SX				.0313		●	●	●	●	●	●	●	●	●	●	●	
DNMG433 ESX		DNMG150412N-SX				.0469		●	●	●	●	●	●	●	●	●	●	●	



Negative Inserts



Swiss Tooling

55° DIAMOND TYPE

NEGATIVE INSERT

Indexable Inserts for Turning

DN

55° Diamond Type

Negative

With Insert Hole

- P** Steel
- M** Stainless Steel
- K** Cast Iron
- N** Non-ferrous
- S** Exotic Materials
- H** Hardened Steel

- USA Stocked Item
- ★ Worldwide Warehouse Item
- ▲ USA Limited Availability Item
- In stock by 1st Quarter 2017

Negative Inserts

C

D

R

S

T

V

W

Swiss Tooling

DNMG EUP		Rake Angle: 10°	Cutting Conditions:					Coated						Uncoated	
			Continuous Cut	Medium Cut	Interrupted Cut	AC6040M	AC8025P	AC820P	AC830P	AC530U	AC510U	AC520U	G10E	EH510	
Sumitomo Catalog #		ISO Catalog #	I.C.	T	r	ød1	AC6040M	AC8025P	AC820P	AC830P	AC530U	AC510U	AC520U	G10E	EH510
DNMG431EUP		DNMG150404N-UP			.0156	.2031	●	●	●	●	●	●	●	●	●
DNMG432EUP		DNMG150408N-UP	.500	.1875	.0313		●	●	●	●	●	●	●	●	★
DNMG433EUP		DNMG150412N-UP			.0469		●	●	●	●	●	●	●	●	●

DNMG EEG		Rake Angle: 0°	Cutting Conditions:					Coated			Cermet	Uncoated				
			Continuous Cut	Medium Cut	Interrupted Cut	AC6020M	AC6030M	AC6040M	AC610M	AC630M	AC8025P	AC510U	AC520U	EH510	EH520	
Sumitomo Catalog #		ISO Catalog #	I.C.	T	r	ød1	AC6020M	AC6030M	AC6040M	AC610M	AC630M	AC8025P	AC510U	AC520U	EH510	EH520
DNMG332EEG		DNMG110408N-EG	.375		.0313	.150	○	●	●	●	●	●	●	●	●	●
DNMG333EEG		DNMG110412N-EG			.0469		○	●	●	●	●	●	●	●	●	●
DNMG431EEG		DNMG150404N-EG		.1875	.0156		○	●	●	●	●	●	●	●	●	●
DNMG432EEG		DNMG150408N-EG	.500		.0313	.2031	○	●	●	●	●	●	●	●	●	●
DNMG433EEG		DNMG150412N-EG			.0469		○	●	●	●	●	●	●	●	●	●

DNMG EEX		Rake Angle: 16°	Cutting Conditions:					Coated						Uncoated		
			Continuous Cut	Medium Cut	Interrupted Cut	AC6020M	AC6030M	AC6040M	AC610M	AC630M	AC530U	AC510U	AC520U	EH510	EH520	
Sumitomo Catalog #		ISO Catalog #	I.C.	T	r	ød1	AC6020M	AC6030M	AC6040M	AC610M	AC630M	AC530U	AC510U	AC520U	EH510	EH520
DNMG431EEX		DNMG150404N-EX			.0156	.2031	○	●	●	●	●	●	●	●	●	●
DNMG432EEX		DNMG150408N-EX	.500	.1875	.0313		○	●	●	●	●	●	●	●	●	●
DNMG433EEX		DNMG150412N-EX			.0469		○	●	●	●	●	●	●	●	●	●



DN

55° Diamond Type

Negative

With Insert Hole

- P** Steel
- M** Stainless Steel
- K** Cast Iron
- N** Non-ferrous
- S** Exotic Materials
- H** Hardened Steel

- USA Stocked Item
- ★ Worldwide Warehouse Item
- ▲ USA Limited Availability Item
- In stock by 1st Quarter 2017

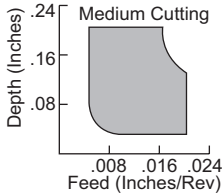
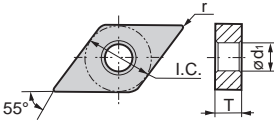
DNMG EGU		Rake Angle: 7°		Cutting Conditions:						Coated						Cermets				
				Continuous Cut						Medium Cut						Interrupted Cut				
																				
Sumitomo Catalog #	ISO Catalog #	I.C.	T	r	ød1	AC810P	AC8025P	AC820P	AC830P	AC700G	YB100	AC6020M	AC6030M	AC6040M	AC610M	AC630M	AC530U	TT1500A	TT200A	
DNMG331EGU	DNMG110404N-GU	.375	.1875	.0156	.150	●	●	●	●	●	●	●	●	●	●	●	●	●	●	
DNMG332EGU	DNMG110408N-GU			.0313			●	●	●	●	●	●	●	●	●	●	●	●	●	●
DNMG431EGU	DNMG150404N-GU	.500	.2031	.0156		●	●	●	●	●	●	●	●	●	●	●	●	●	●	
DNMG432EGU	DNMG150408N-GU			.0313				●	●	●	●	●	●	●	●	●	●	●	●	●
DNMG433EGU	DNMG150412N-GU			.0469		●	●	●	●	●	●	●	●	●	●	●	●	●	●	
DNMG441EGU	DNMG150604N-GU	.250		.0156		●	●	●	●	●	●	●	●	●	●	●	●	●	●	
DNMG442EGU	DNMG150608N-GU			.0313				●	●	●	●	●	●	●	●	●	●	●	●	●
DNMG443EGU	DNMG150612N-GU			.0469				●	●	●	●	●	●	●	●	●	●	●	●	●

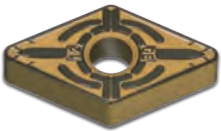
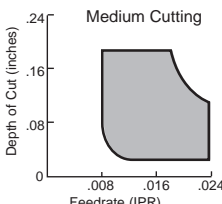
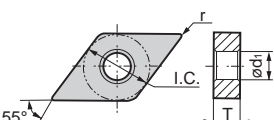
DNMG EGE		Rake Angle: 3°		Cutting Conditions:						Coated			Cermets		Uncoated			
				Continuous Cut						Medium Cut			Interrupted Cut					
																		
Sumitomo Catalog #	ISO Catalog #	I.C.	T	r	ød1	AC805P	AC810P	AC8025P	AC820P	AC830P	AC700G							
DNMG332EGE	DNMG110408N-GE	.375	.1875	.0313	.150	●	●	●	●	●	●							
DNMG333EGE	DNMG110412N-GE			.0469			●	●	●	●	●	●						
DNMG431EGE	DNMG150404N-GE	.500	.2031	.0156		●	●	●	●	●	●							
DNMG432EGE	DNMG150408N-GE			.0313				●	●	●	●	●						
DNMG433EGE	DNMG150412N-GE			.0469		●	●	●	●	●	●							

Negative Inserts

C

D

R

S

T

V

W

Swiss Tooling



55° DIAMOND TYPE

NEGATIVE INSERT

Indexable Inserts for Turning

DN

55° Diamond Type
Negative
With Insert Hole

- P** Steel
- M** Stainless Steel
- K** Cast Iron
- N** Non-ferrous
- S** Exotic Materials
- H** Hardened Steel
- USA Stocked Item
- ★ Worldwide Warehouse Item
- ▲ USA Limited Availability Item
- In stock by 1st Quarter 2017

Negative Inserts

C

D

R

S

T

V

W

Swiss Tooling

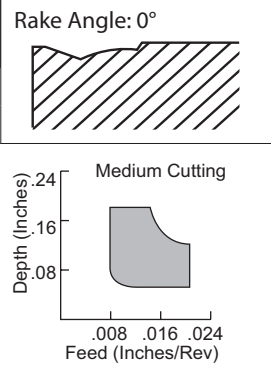
DNMG EUX		Rake Angle: 0°	Cutting Conditions:					Coated							Cermet					
			Continuous Cut		●	●	●	●	●	●	●	●	●	●	●	●	●	●	●	
			Medium Cut		●	●	●	●	●	●	●	●	●	●	●	●	●	●	●	●
			Interrupted Cut		●	●	●	●	●	●	●	●	●	●	●	●	●	●	●	●
Sumitomo Catalog #	ISO Catalog #	I.C.	T	r	Ød1	AC810P	AC8025P	AC820P	AC830P	AC700G	YB100	AC410K	T1200A							
DNMG332EUX	DNMG110408N-UX	.375		.0313	.150	●	●	●	●	●	●	●	●	●	●	●	●	●		
DNMG431EUX	DNMG150404N-UX		.1875	.0156		●	●	●	●	●	●	●	●	●	●	●	●	●		
DNMG432EUX	DNMG150408N-UX			.0313		●	●	●	●	●	●	●	●	●	●	●	●	●		
DNMG433EUX	DNMG150412N-UX	.500		.0469	.2031	●	●	●	●	●	●	●	●	●	●	●	●	●		
DNMG442EUX	DNMG150608N-UX			.0313		●	●	●	●	●	●	●	●	●	●	●	●	●		
DNMG443EUX	DNMG150612N-UX		.250	.0469		●	●	●	●	●	●	●	●	●	●	●	●	●		

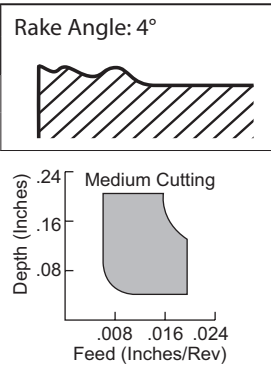
DNMG ENG		Rake Angle: 4°	Cutting Conditions:					Coated							Cermet					
			Continuous Cut		●	●	●	●	●	●	●	●	●	●	●	●	●	●		
			Medium Cut		●	●	●	●	●	●	●	●	●	●	●	●	●	●	●	●
			Interrupted Cut		●	●	●	●	●	●	●	●	●	●	●	●	●	●	●	●
Sumitomo Catalog #	ISO Catalog #	I.C.	T	r	Ød1	AC8025P	AC820P	AC830P	AC700G											
DNMG331ENG	DNMG110404N-UG	.375		.0156	.150	●	●	●	●	●	●	●	●	●	●	●	●	●		
DNMG332ENG	DNMG110408N-UG			.0313		●	●	●	●	●	●	●	●	●	●	●	●	●		
DNMG431ENG	DNMG150404N-UG		.1875	.0156		●	●	●	●	●	●	●	●	●	●	●	●	●		
DNMG432ENG	DNMG150408N-UG	.500		.0313	.2031	●	●	●	●	●	●	●	●	●	●	●	●	●		
DNMG433ENG	DNMG150412N-UG			.0469		●	●	●	●	●	●	●	●	●	●	●	●	●		
DNMG542ENG	DNMG190608N-UG	.625	.250	.0313	.250	●	●	●	●	●	●	●	●	●	●	●	●	●		
DNMG543ENG	DNMG190612N-UG			.0469		●	●	●	●	●	●	●	●	●	●	●	●	●		



DN

55° Diamond Type

Negative

With Insert Hole

- P Steel
- M Stainless Steel
- K Cast Iron
- N Non-ferrous
- S Exotic Materials
- H Hardened Steel

- USA Stocked Item
- ★ Worldwide Warehouse Item
- ▲ USA Limited Availability Item
- In stock by 1st Quarter 2017

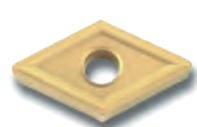
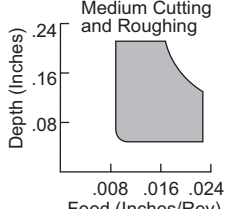
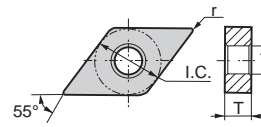
DNMG		Rake Angle: 4°		Cutting Conditions:						Coated						Uncoated						
ENZ/FNZ				Continuous Cut						Medium Cut						Interrupted Cut						
																						
Sumitomo Catalog #	ISO Catalog #	I.C.	T	r	ød1	AC8025P	AC820P	AC830P	AC700G	AC405K	AC410K	AC415K	AC420K	G10E								
DNMG431ENZ	DNMG150404N-UZ		.1875	.0313																		
DNMG432ENZ	DNMG150408N-UZ			.0469																		
DNMG433ENZ	DNMG150412N-UZ	.500		.0313	.2031																	
DNMG442ENZ	DNMG150608N-UZ			.0469																		
DNMG443ENZ	DNMG150612N-UZ			.0313																		
DNMG542ENZ	DNMG190608N-UZ		.250	.0313																		
DNMG543ENZ	DNMG190612N-UZ	.625		.0469	.250																	
DNMG544ENZ	DNMG190616N-UZ			.0625																		
DNMG432FNZ	DNMG150408N-UZ	.500	.1875	.0313	.2031																	

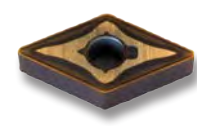
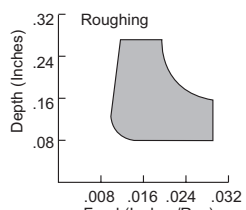
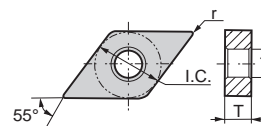
DNMG		Rake Angle: 0°		Cutting Conditions:						Coated						Uncoated					
EEM				Continuous Cut						Medium Cut						Interrupted Cut					
																					
Sumitomo Catalog #	ISO Catalog #	I.C.	T	r	ød1	AC8025P	AC6020M	AC6030M	AC6040M	AC510U	AC520U										
DNMG432EEM	DNMG150408N-EM			.0313																	
DNMG433EEM	DNMG150412N-EM	.500	.1875	.0469	.2031																
DNMG434EEM	DNMG150416N-EM			.0625																	



55° DIAMOND TYPE

NEGATIVE INSERT

Indexable Inserts for Turning

DN

55° Diamond Type

Negative

With Insert Hole

- P** Steel
- M** Stainless Steel
- K** Cast Iron
- N** Non-ferrous
- S** Exotic Materials
- H** Hardened Steel

- USA Stocked Item
- ★ Worldwide Warehouse Item
- ▲ USA Limited Availability Item
- In stock by 1st Quarter 2017

Negative Inserts

C

D

R

S

T

V

W

Swiss Tooling

DNMG EMU		Rake Angle: 4° 	Cutting Conditions:						Coated										Uncoated			
			Continuous Cut	Medium Cut	Interrupted Cut	AC810P	AC8025P	AC820P	AC830P	AC700G	YB100	AC6030M	AC6040M	AC630M	AC530U	AC510U	AC520U	EH520				
 Depth (Inches) vs Feed (Inches/Rev) graph I.C., T, r, ød1 diagram																						
Sumitomo Catalog #	ISO Catalog #	I.C.	T	r	ød1																	
DNMG432EMU	DNMG150408N-MU	.500	.1875	.0313	.2031	●	●	●	●	●	●	●	●	●	●	●	●	●	●	●	●	●
DNMG433EMU	DNMG150412N-MU			.0469		●	●	●	●	●	●	●	●	●	●	●	●	●	●	●	●	●
DNMG434EMU	DNMG150416N-MU			.0625		●	●	●	●	●	●	●	●	●	●	●	●	●	●	●	●	●
DNMG442EMU	DNMG150608N-MU			.0313		●	●	●	●	●	●	●	●	●	●	●	●	●	●	●	●	●
DNMG443EMU	DNMG150612N-MU		.250	.0469		●	●	●	●	●	●	●	●	●	●	●	●	●	●	●	●	●
DNMG444EMU	DNMG150616N-MU			.0625		●	●	●	●	●	●	●	●	●	●	●	●	●	●	●	●	●

DNMG EME		Rake Angle: 4° 	Cutting Conditions:						Coated										Uncoated			
			Continuous Cut	Medium Cut	Interrupted Cut	AC805P	AC810P	AC8025P	AC820P	AC830P												
 Depth (Inches) vs Feed (Inches/Rev) graph I.C., T, r, ød1 diagram																						
Sumitomo Catalog #	ISO Catalog #	I.C.	T	r	ød1																	
DNMG432EME	DNMG150408N-ME	.500	.1875	.0313	.2031	●	●	●	●	●												
DNMG433EME	DNMG150412N-ME			.0469		●	●	●	●	●	●	●										
DNMG442EME	DNMG150608N-ME			.0313		●	●	●	●	●												
DNMG443EME	DNMG150612N-ME		.250	.0469		●	●	●	●	●												
DNMG444EME	DNMG150616N-ME			.0625		●	●	●	●	●												



DN 55° Diamond Type
Negative
With Insert Hole

- P** Steel
- M** Stainless Steel
- K** Cast Iron
- N** Non-ferrous
- S** Exotic Materials
- H** Hardened Steel

- USA Stocked Item
- ★ Worldwide Warehouse Item
- ▲ USA Limited Availability Item
- In stock by 1st Quarter 2017

DNMG EMX		Rake Angle: -15°	Cutting Conditions:				Coated				Uncoated							
			Continuous Cut ● ● ● ● ● ● Medium Cut ● ● ● ● ● ● Interrupted Cut ● ● ● ● ● ●															
							AC8025P				AC820P				AC830P			
Sumitomo Catalog #	ISO Catalog #	I.C.	T	r	ød1													
DNMG432EMX	DNMG150408N-MX			.0313														
DNMG433EMX	DNMG150412N-MX	.500	.1875	.0469	.2031													
DNMG434EMX	DNMG150416N-MX			.0625														

DNMG EGZ		Rake Angle: 0°	Cutting Conditions:				Coated		Cermet		Uncoated					
			Continuous Cut ● ● ● ● ● ● Medium Cut ● ● ● ● ● ● Interrupted Cut ● ● ● ● ● ●													
							AC405K		AC410K		AC415K		AC420K			
Sumitomo Catalog #	ISO Catalog #	I.C.	T	r	ød1											
DNMG332EGZ	DNMG110408N-GZ			.0313	.150											
DNMG333EGZ	DNMG110412N-GZ	.375		.0469												
DNMG431EGZ	DNMG150404N-GZ		.1875	.0156												
DNMG432EGZ	DNMG150408N-GZ	.500		.0313	.2031											
DNMG433EGZ	DNMG150412N-GZ			.0469												

DNMA		No Breaker	Cutting Conditions:				Coated				Uncoated															
			Continuous Cut ● ● ● ● ● ● Medium Cut ● ● ● ● ● ● Interrupted Cut ● ● ● ● ● ●																							
							AC700G				AC405K				AC410K				AC415K				AC420K			
Sumitomo Catalog #	ISO Catalog #	I.C.	T	r	ød1																					
DNMA431	DNMA150404			.0156																						
DNMA432	DNMA150408		.1875	.0313																						
DNMA433	DNMA150412	.500		.0469	.2031																					
DNMA442	DNMA150608			.0313																						
DNMA443	DNMA150612		.250	.0469																						

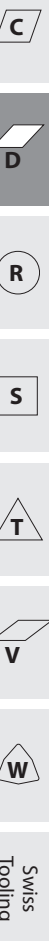

ROUND TYPE

NEGATIVE INSERT

Indexable Inserts for Turning

RN

Round Type

Negative

With Insert Hole

- P** Steel
- M** Stainless Steel
- K** Cast Iron
- N** Non-ferrous
- S** Exotic Materials
- H** Hardened Steel

- USA Stocked Item
- ★ Worldwide Warehouse Item
- ▲ USA Limited Availability Item
- In stock by 1st Quarter 2017

Negative Inserts

C

D

R



S



T

V

W

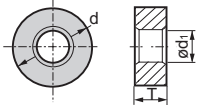
Swiss Tooling

RNMG ENT		Rake Angle: 0° 	Cutting Conditions:				Coated		Cermet		Uncoated	
			Continuous Cut	Medium Cut	Interrupted Cut							
 			Continuous Cut	Medium Cut	Interrupted Cut							
Sumitomo Catalog #	ISO Catalog #	I.C.	T	r	ød1	AC830P						
RNMG43ENT		.500	.1875	-	.2031	●						

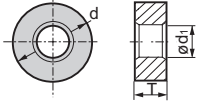
RNMG ENU		Rake Angle: 0° 	Cutting Conditions:				Coated		Cermet		Uncoated	
			Continuous Cut	Medium Cut	Interrupted Cut							
 			Continuous Cut	Medium Cut	Interrupted Cut							
Sumitomo Catalog #	ISO Catalog #	I.C.	T	r	ød1	AC830P						
RNMG54ENU		.625	.250	-	.250	●						



ROUND TYPE NEGATIVE INSERT

RN



Round Type



Negative

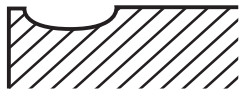

With Insert Hole

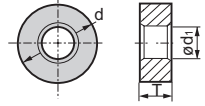
- P** Steel
- M** Stainless Steel
- K** Cast Iron
- N** Non-ferrous
- S** Exotic Materials
- H** Hardened Steel

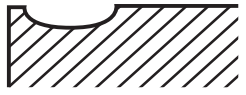
- USA Stocked Item
- ★ Worldwide Warehouse Item
- ▲ USA Limited Availability Item
- In stock by 1st Quarter 2017

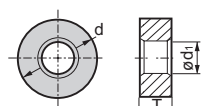
RNMG		Rake Angle: 0°	Cutting Conditions:				Coated	Cermet	Uncoated
ENV			Continuous Cut						
			Medium Cut				●		
			Interrupted Cut				●		
			AC830P						
Sumitomo Catalog #	ISO Catalog #	I.C.							
RNMG64ENV		.750	.250	-	.3126				

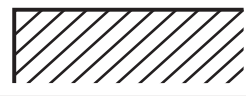
RNMG		Rake Angle: 0°	Cutting Conditions:				Coated	Cermet	Uncoated
ENY			Continuous Cut						
			Medium Cut				●		
			Interrupted Cut				●		
			AC830P						
Sumitomo Catalog #	ISO Catalog #	I.C.							
RNMG84ENY		1.00	.250	-	.3622				
RNMG86ENY			.375	-					

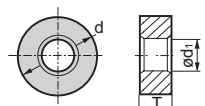
RNMA		No Breaker	Cutting Conditions:				Coated	Cermet	Uncoated
			Continuous Cut				●		
			Medium Cut				●		
			Interrupted Cut				●		
			AC700G AC405K AC415K						
Sumitomo Catalog #	ISO Catalog #	I.C.							
RNMA43		.500	.1875	-	.2031				



Negative Inserts

C

D

R

S

T

V

W

Swiss Tooling

90° SQUARE TYPE

NEGATIVE INSERT

Indexable Inserts for Turning

SN

90° Square Type

Negative

- P** Steel
- M** Stainless Steel
- K** Cast Iron
- N** Non-ferrous
- S** Exotic Materials
- H** Hardened Steel

- USA Stocked Item
- ★ Worldwide Warehouse Item
- ▲ USA Limited Availability Item
- In stock by 1st Quarter 2017

Negative Inserts

C

D

R

S

T

V

W

Swiss Tooling

SNP _{R/L} T		Rake Angle: 0° 	Cutting Conditions:				Coated			Cermet			Uncoated				
			Continuous Cut	Medium Cut	Interrupted Cut												
		Depth (Inches) Feed (Inches/Rev)															
Sumitomo Catalog #		ISO Catalog #	I.C.	T	r	ød1											
SNPR321T	SNPL321T	SNGG090304R-ST			.0156												
		SNGG090304L-ST			.0156												
SNPR322T	SNPL322T	SNGG090308R-ST	.375	.125	.0313	.150											
		SNGG090308L-ST			.0313												
SNPR323T		SNGG090312R-ST			.0469												

SNP _{R/L} M		Rake Angle: 14° 	Cutting Conditions:				Coated			Cermet			Uncoated				
			Continuous Cut	Medium Cut	Interrupted Cut												
		Depth (Inches) Feed (Inches/Rev)															
Sumitomo Catalog #		ISO Catalog #	I.C.	T	r	ød1											
SNPR431M	SNPL431M	SNGG120404R-UM			.0156												
		SNGG120404L-UM			.0156												
SNPR432M	SNPL432M	SNGG120408R-UM	.500	.1875	.0313	.2031											
		SNGG120408L-UM			.0313												
SNPR433M	SNPL433M	SNGG120412R-UM			.0469												
		SNGG120412L-UM			.0469												

SNG		No Breaker 	Cutting Conditions:				Coated			Cermet			Uncoated				
			Continuous Cut	Medium Cut	Interrupted Cut												
Sumitomo Catalog #		ISO Catalog #	I.C.	T	r	ød1											
SNG432		SNGN120408	.500	.1875	.0313	-											



SN 90° Square Type
Negative
With Insert Hole

- P** Steel
- M** Stainless Steel
- K** Cast Iron
- N** Non-ferrous
- S** Exotic Materials
- H** Hardened Steel

- USA Stocked Item
- ★ Worldwide Warehouse Item
- ▲ USA Limited Availability Item
- In stock by 1st Quarter 2017

SNMG EFL		Rake Angle: 10°	Cutting Conditions:						Coated		Cermets			Uncoated				
			Continuous Cut Medium Cut Interrupted Cut						● ●		● ●	● ●						
									AC8025P	AC820P	T1500Z	T2000Z	T3000Z					
Sumitomo Catalog #	ISO Catalog #	I.C.	T	r	ød1													
SNMG432EFL	SNMG120408N-FL	.500	.1875	.0313	.2031			● ●		● ★	★							

SNMG EFJ		Rake Angle: 0°	Cutting Conditions:						Coated		Cermets			Uncoated			
			Continuous Cut Medium Cut Interrupted Cut								● ●	● ●					
											T1500A	T1200A					
Sumitomo Catalog #	ISO Catalog #	I.C.	T	r	ød1												
SNMG322EFJ	SNMG090308N-FJ	.375	.125	.0313	.150					★	●						
SNMG431EFJ	SNMG120404N-FJ	.500	.1875	.0156	.2031						●						

SNMG ESU		Rake Angle: 13°	Cutting Conditions:						Coated						Cermets			Uncoated						
			Continuous Cut Medium Cut Interrupted Cut						● ● ● ● ● ●	● ● ● ● ● ●	● ● ● ● ● ●	● ● ● ● ● ●	● ● ● ● ● ●	● ● ● ● ● ●	● ● ● ● ● ●	● ● ● ● ● ●	● ● ● ● ● ●							
									AC810P	AC8025P	AC820P	AC830P	AC700G	AC6030M	AC630M	AC530U	AC510U	AC520U	T1500Z	T2000Z	T3000Z	T1500A	T1200A	EH510
Sumitomo Catalog #	ISO Catalog #	I.C.	T	r	ød1																			
SNMG432 ESU	SNMG120408N-SU	.500	.1875	.0313	.2031			●	●	●	●	●	●	●	●	●	●	●	●	●	●	●	●	

Negative Inserts

C

D

R

S

T

V

W

Swiss Tooling



90° SQUARE TYPE

NEGATIVE INSERT

Indexable Inserts for Turning

SN

90° Square Type

Negative

With Insert Hole

- P** Steel
- M** Stainless Steel
- K** Cast Iron
- N** Non-ferrous
- S** Exotic Materials
- H** Hardened Steel

- USA Stocked Item
- ★ Worldwide Warehouse Item
- ▲ USA Limited Availability Item
- In stock by 1st Quarter 2017

Negative Inserts

C

D

R



S



T

V

W

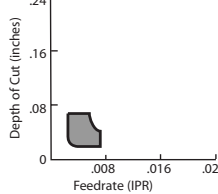
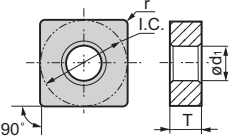
Swiss Tooling

SNMG		Rake Angle: 20°	Cutting Conditions:						Coated			Cermet			Uncoated				
EEF			Continuous Cut ● ● ● ● ● ● ● ● Medium Cut ● ● ● ● ● ● ● ● Interrupted Cut ● ● ● ● ● ● ● ●																
									AC6020M	AC6040M									
Sumitomo Catalog #		ISO Catalog #	I.C.	T	r	ød1	AC6020M	AC6040M											
SNMG431EEF		SNMG120404N-EF	.500	.1875	.0156	.2031	○	●											
SNMG432EEF		SNMG120408N-EF			.0313		○												

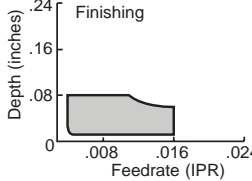
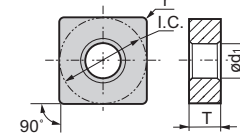
SNMG		Rake Angle: 5°	Cutting Conditions:						Coated			Cermet			Uncoated				
ESE			Continuous Cut ● ● ● ● ● ● ● ● Medium Cut ● ● ● ● ● ● ● ● Interrupted Cut ● ● ● ● ● ● ● ●																
									AC810P	AC8025P	AC820P	AC830P							
Sumitomo Catalog #		ISO Catalog #	I.C.	T	r	ød1	AC810P	AC8025P	AC820P	AC830P									
SNMG432ESE		SNMG120408N-SE	.500	.1875	.0313	.2031	●	●	●	●									
SNMG433ESE		SNMG120412N-SE			.0469		●												

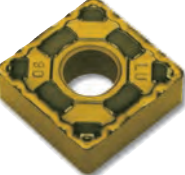
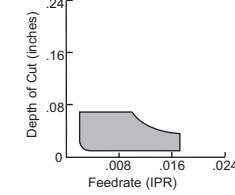
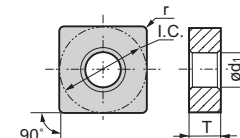
SNMG		Rake Angle: 10°	Cutting Conditions:						Coated			Cermet			Uncoated				
ELU			Continuous Cut ● ● ● ● ● ● ● ● Medium Cut ● ● ● ● ● ● ● ● Interrupted Cut ● ● ● ● ● ● ● ●																
									AC810P	AC820P	AC700G		T1500Z	T2000Z	T3000Z	T1500A			
Sumitomo Catalog #		ISO Catalog #	I.C.	T	r	ød1	AC810P	AC820P	AC700G		T1500Z	T2000Z	T3000Z	T1500A					
SNMG432ELU		SNMG120408N-LU	.500	.1875	.0313	.2031	●	●	●		★	●	★	●					
SNMG433ELU		SNMG120412N-LU			.0469		●	★	★			★	★	●					



SN

90° Square Type

Negative

With Insert Hole

- P** Steel
- M** Stainless Steel
- K** Cast Iron
- N** Non-ferrous
- S** Exotic Materials
- H** Hardened Steel

- USA Stocked Item
- ★ Worldwide Warehouse Item
- ▲ USA Limited Availability Item
- In stock by 1st Quarter 2017

SNMG ENK		Rake Angle: 10°	Cutting Conditions:						Coated			Cermet			Uncoated					
									Continuous Cut	●					●					
									Medium Cut	●					●					
									Interrupted Cut	●					●					
		<p>Light Cutting</p> <p>Depth (Inches): .24, .16, .08</p> <p>Feed (Inches/Rev): .008, .016, .024</p>							AC820P			T1200A								
Sumitomo Catalog #	ISO Catalog #	I.C.	T	r	ød1															
SNMG321ENK	SNMG090304N-SK	.375	.125	.0156	.150															
SNMG322ENK	SNMG090308N-SK			.0313																
SNMG431ENK	SNMG120404N-SK	.500	.1875	.0156	.2031															
SNMG432ENK	SNMG120408N-SK			.0313																

SNMG ENJ		Rake Angle: 0°	Cutting Conditions:						Coated			Cermet			Uncoated				
									Continuous Cut	●	●								
									Medium Cut	●	●								
									Interrupted Cut	●									
		<p>Medium Cutting</p> <p>Depth (Inches): .24, .16, .08</p> <p>Feed (Inches/Rev): .008, .016, .024</p>							AC820P			AC830P							
Sumitomo Catalog #	ISO Catalog #	I.C.	T	r	ød1														
SNMG322ENJ	SNMG090308N-UJ	.375	.125	.0313	.150														
SNMG431ENJ	SNMG120404N-UJ	.500	.1875	.0156	.2031														

SNMG ESX		Rake Angle: 3°	Cutting Conditions:						Coated					Cermet					Uncoated			
									Continuous Cut	●	●	●	●	●	●	●	●	●	●			
									Medium Cut	●	●	●	●	●	●	●	●	●	●			
									Interrupted Cut	●	●	●	●	●	●	●	●	●	●			
		<p>Light Cutting</p> <p>Depth (Inches): .24, .16, .08</p> <p>Feed (Inches/Rev): .008, .016, .024</p>							AC810P					AC8025P								
									AC820P					AC830P								
									AC700G					T1500Z								
														T2000Z								
														T3000Z								
														T1500A								
														T1200A								
Sumitomo Catalog #	ISO Catalog #	I.C.	T	r	ød1																	
SNMG431ESX	SNMG120404N-SX	.500	.1875	.0156	.2031																	
SNMG432ESX	SNMG120408N-SX			.0313																		
SNMG433ESX	SNMG120412N-SX			.0469																		

Negative Inserts

C

D

R

S

T

V

W

Swiss Tooling



90° SQUARE TYPE

NEGATIVE INSERT

Indexable Inserts for Turning

SN

90° Square Type

Negative

With Insert Hole

- P** Steel
- M** Stainless Steel
- K** Cast Iron
- N** Non-ferrous
- S** Exotic Materials
- H** Hardened Steel

- USA Stocked Item
- ★ Worldwide Warehouse Item
- ▲ USA Limited Availability Item
- In stock by 1st Quarter 2017

Negative Inserts

C

D

R



S

T

V

W

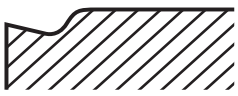
Swiss Tooling

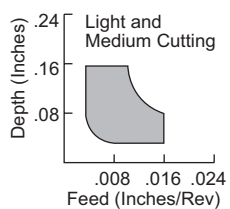
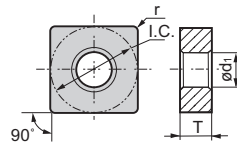
SNMG EUP		Rake Angle: 10° 	Cutting Conditions:					Coated					Uncoated								
			Continuous Cut	Medium Cut	Interrupted Cut	●	●	●	●	●	●	●	●	●	●	●	●				
		Depth (Inches) Feedrate (Inches/Rev)	Light and Medium Cutting 				AC6040M	AC8025P	AC820P	AC830P	AC530U										
Sumitomo Catalog #	ISO Catalog #	I.C.	T	r	ød1																
SNMG431 EUP	SNMG120404N-UP			.0156																	
SNMG432 EUP	SNMG120408N-UP	.500	.1875	.0313	.2031	●	●	●	●	●											
SNMG433 EUP	SNMG120412N-UP			.0469		●	●	●	●	●											

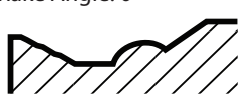
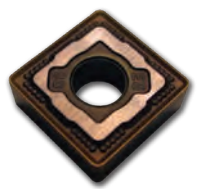
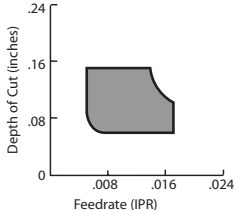
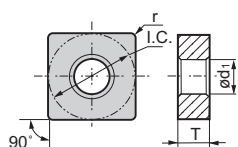
SNMG EEG		Rake Angle: 0° 	Cutting Conditions:					Coated			Cermet		Uncoated								
			Continuous Cut	Medium Cut	Interrupted Cut	●	●	●	●	●	●	●	●								
		Depth of Cut (Inches) Feedrate (IPR)					AC6020M	AC6030M	AC6040M	AC630M	AC8025P	AC510U	AC520U								
Sumitomo Catalog #	ISO Catalog #	I.C.	T	r	ød1																
SNMG431EEG	SNMG120404N-EG			.0156		○	○	○	○	○	○	○									
SNMG432EEG	SNMG120408N-EG	.500	.1875	.0313	.2031	○	●	●	●	●	●	●									
SNMG433EEG	SNMG120412N-EG			.0469		○	●	●	●	●	●	●									
SNMG542EEG	SNMG120608N-EG			.0313		○	○	○	○	○	○	○									
SNMG543EEG	SNMG120612N-EG	.625		.0469		○	●	●	●	●	●	●									
SNMG544EEG	SNMG120616N-EG		.250	.0625	.250	○	●	●	●	●	●	●									
SNMG643EEG	SNMG190612N-EG			.0469		○	●	●	●	●	●	●									
SNMG644EEG	SNMG190616N-EG	.750		.0625		○	●	●	●	●	●	●									



SN



90° Square Type



Negative

With Insert Hole

- P Steel
- M Stainless Steel
- K Cast Iron
- N Non-ferrous
- S Exotic Materials
- H Hardened Steel

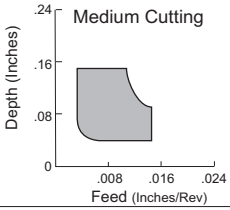
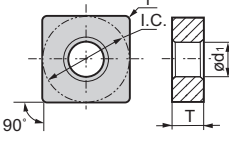
- USA Stocked Item
- ★ Worldwide Warehouse Item
- ▲ USA Limited Availability Item
- In stock by 1st Quarter 2017

SNMG		Rake Angle: 16°	Cutting Conditions:						Coated				Uncoated						
EEX																			
		Medium Cutting 																	
Sumitomo Catalog #	ISO Catalog #	I.C.	T	r	ød1	AC6020M	AC6030M	AC6040M	AC610M	AC630M	AC530U	AC510U	AC520U	EH510	EH520				
SNMG322EEX	SNMG090308N-EX	.375	.125	.0313	.150														
SNMG431EEX	SNMG120404N-EX			.0156															
SNMG432EEX	SNMG120408N-EX	.500	.1875	.0313	.2031														
SNMG433EEX	SNMG120412N-EX			.0469															
SNMG543EEX	SNMG150612N-EX	.625	.250	.0469	.250														
SNMG643EEX	SNMG190612N-EX	.750		.0469	.3126														

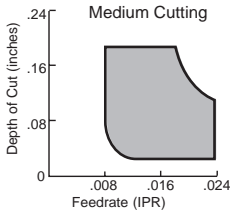
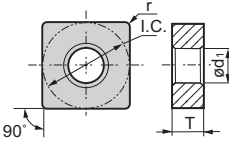
SNMG		Rake Angle: 3°	Cutting Conditions:						Coated				Cermet				Uncoated			
EGE																				
		Medium Cutting 																		
Sumitomo Catalog #	ISO Catalog #	I.C.	T	r	ød1	AC810P	AC8025P	AC820P	AC830P											
SNMG432EGE	SNMG120408N-GE			.0313																
SNMG433EGE	SNMG120412N-GE	.500	.1875	.0469	.2031															
SNMG434EGE	SNMG120416N-GE			.0625																
SNMG543EGE	SNMG150612N-GE	.625	.250	.0469	.250															
SNMG544EGE	SNMG150616N-GE			.0625																



Negative Inserts



Swiss Tooling

90° SQUARE TYPE

NEGATIVE INSERT

Indexable Inserts for Turning

SN

90° Square Type

Negative

With Insert Hole

- P** Steel
- M** Stainless Steel
- K** Cast Iron
- N** Non-ferrous
- S** Exotic Materials
- H** Hardened Steel

- USA Stocked Item
- ★ Worldwide Warehouse Item
- ▲ USA Limited Availability Item
- In stock by 1st Quarter 2017

Negative Inserts

C

D

R

S

T

V

W

Swiss Tooling

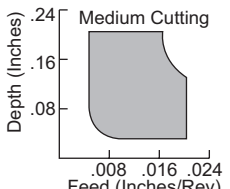
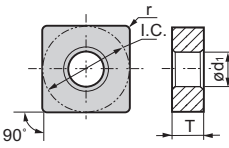
SNMG EGU		Rake Angle: 7°	Cutting Conditions:						Coated					Cermet		Uncoated					
			Continuous Cut	Medium Cut	Interrupted Cut	●	●	●	●	●	●	●	●	●	●	●	●				
																					
Sumitomo Catalog #	ISO Catalog #	I.C.	T	r	ød1	AC810P	AC8025P	AC820P	AC830P	AC700G	AC6020M	AC6030M	AC6040M	AC610M	AC630M	AC530U	T1500A	T1200A			
SNMG321EGU	SNMG090304N-GU	.375	.125	.0156	.150	●	●	●	●	●											
SNMG322EGU	SNMG090308N-GU			.0313		●	●	●	●	●											
SNMG431EGU	SNMG120404N-GU			.0156		★	●	●	●	●											
SNMG432EGU	SNMG120408N-GU			.0313		●	●	●	●	●											
SNMG433EGU	SNMG120412N-GU	.500	.1875	.0469	.2031	●	●	●	●	●	○	○	○	★	★	★	★	★	★	★	▲
SNMG434EGU	SNMG120416N-GU			.0625		●	●	●	●	●											
SNMG543EGU	SNMG150612N-GU	.625	.250	.0469	.250	★	●	●	●	●	★	★									

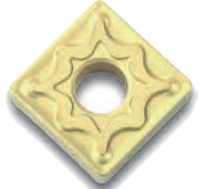
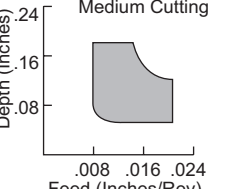
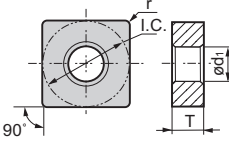
SNMG EUX		Rake Angle: 0°	Cutting Conditions:						Coated					Cermet		Uncoated					
			Continuous Cut	Medium Cut	Interrupted Cut	●	●	●	●	●	●	●	●	●	●	●	●				
																					
Sumitomo Catalog #	ISO Catalog #	I.C.	T	r	ød1	AC810P	AC8025P	AC820P	AC830P	AC700G	YB100	AC410K									
SNMG322EUX	SNMG090308N-UX	.375	.125	.0313	.150	●	●	●	●	●											
SNMG431EUX	SNMG120404N-UX			.0156		●	●	●	●	●											
SNMG432EUX	SNMG120408N-UX			.0313		●	●	●	●	●											
SNMG433EUX	SNMG120412N-UX	.500	.1875	.0469	.2031	●	●	●	●	●	●	▲									
SNMG434EUX	SNMG120416N-UX			.0625		★	●	●	●	●											
SNMG643EUX	SNMG190612N-UX			.0469		●	●	●	●	★		▲									
SNMG644EUX	SNMG190616N-UX	.750	.250	.0625	.3126	●	●	●	●	★		▲									



SN

90° Square Type

Negative

With Insert Hole

- P Steel
- M Stainless Steel
- K Cast Iron
- N Non-ferrous
- S Exotic Materials
- H Hardened Steel

- USA Stocked Item
- ★ Worldwide Warehouse Item
- ▲ USA Limited Availability Item
- In stock by 1st Quarter 2017

SNMG ENG		Rake Angle: 4°	Cutting Conditions:						Coated				Cermet				
			Continuous Cut						●	●	●	●	●	●	●	●	
			Medium Cut						●	●	●	●	●	●	●	●	
			Interrupted Cut						●	●	●	●	●	●	●	●	
		 Depth (Inches) vs Feed (Inches/Rev)							AC8025P	AC820P	AC830P	AC700G	T1200A				
Sumitomo Catalog #	ISO Catalog #	I.C.	T	r	ød1	●	●	●	●	●	●	●	●	●	●	●	●
SNMG322ENG	SNMG090308N-UG	.375	.125	.0313	.150	●	●	●	●					▲			
SNMG432ENG	SNMG120408N-UG			.0313		●	●	●	●					▲			
SNMG433ENG	SNMG120412N-UG	.500	.1875	.0469	.2031	●	★	●	●								
SNMG434ENG	SNMG120416N-UG			.0625		●	●	●	●								
SNMG543ENG	SNMG150612N-UG	.625		.0469	.250	●	●	●	●								
SNMG643ENG	SNMG190612N-UG	.750	.250	.0469	.3126	●	●	●	●								
SNMG644ENG	SNMG190616N-UG			.0625		●	●	●	★								
SNMG866ENG	SNMG250924N-UG	1.00	.375	.0938	.3622	●	●	●	●								

SNMG ENZ/FNZ		Rake Angle: 4°	Cutting Conditions:						Coated						Uncoated			
			Continuous Cut						●	●	●	●	●	●	●	●		
			Medium Cut						●	●	●	●	●	●	●	●		
			Interrupted Cut						●	●	●	●	●	●	●	●		
		 Depth (Inches) vs Feed (Inches/Rev)							AC8025P	AC820P	AC830P	AC700G	AC405K	AC410K	AC415K	AC420K	G10E	
Sumitomo Catalog #	ISO Catalog #	I.C.	T	r	ød1	●	●	●	●	●	●	●	●	●	●	●		
SNMG432ENZ	SNMG120408N-UZ			.0313		●	●	●	●									
SNMG433ENZ	SNMG120412N-UZ	.500	.1875	.0469	.2031	●	●	●	●									
SNMG434ENZ	SNMG120416N-UZ			.0625		●	●	●	●									
SNMG543ENZ	SNMG150612N-UZ	.625		.0469	.250	●	●	●	●									
SNMG544ENZ	SNMG150616N-UZ			.0625		●	●	●	●									
SNMG642ENZ	SNMG190608N-UZ		.250	.0313		●	●	●	●									
SNMG643ENZ	SNMG190612N-UZ	.750		.0469	.3126	●	●	●	●									
SNMG644ENZ	SNMG190616N-UZ			.0625		●	●	●	●			▲	●					
SNMG866ENZ	SNMG250924N-UZ	1.00	.375	.0938	.3622	●	●	●	●									
SNMG433FNZ	SNMG120412N-UZ	.500	.1875	.0469	.2031	●	●	●	●					●				



Negative Inserts



Swiss Tooling

90° SQUARE TYPE

NEGATIVE INSERT

Indexable Inserts for Turning

SN

90° Square Type

Negative

With Insert Hole

- P** Steel
- M** Stainless Steel
- K** Cast Iron
- N** Non-ferrous
- S** Exotic Materials
- H** Hardened Steel

- USA Stocked Item
- ★ Worldwide Warehouse Item
- ▲ USA Limited Availability Item
- In stock by 1st Quarter 2017

Negative Inserts

C

D

R

S



T

V

W

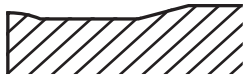
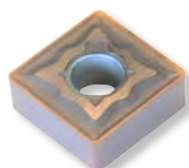
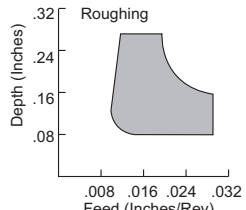
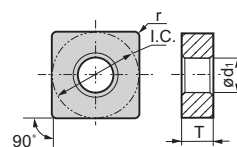
Swiss Tooling

<h2>SNMG EEM</h2> <p>Rake Angle: 0°</p> 		Cutting Conditions:						Coated						Uncoated					
		Continuous Cut						Medium Cut						Interrupted Cut					
  								AC8025P	AC6020M	AC6030M	AC6040M	AC510U	AC520U						
Sumitomo Catalog #	ISO Catalog #	I.C.	T	r	ød1														
SNMG432EEM	SNMG120408N-EM	.500	.1875	.0313	.2031														
SNMG433EEM	SNMG120404N-EM			.0469															
SNMG542EEM	SNMG150608N-EM			.0313															
SNMG543EEM	SNMG150612N-EM	.625	.250	.0469	.250														
SNMG544EEM	SNMG150616N-EM			.0625															
SNMG643EEM	SNMG190612N-EM			.0469															
SNMG644EEM	SNMG190612N-EM	.750	.250	.0625	.3126														
SNMG646EEM	SNMG190624N-EM			.0938															
SNMG866EEM	SNMG250924N-EM	1.00	.375	.0938	.3622														

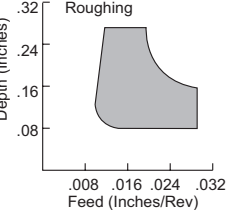
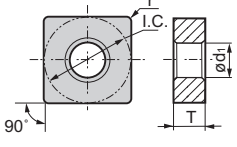
<h2>SNMG EMU</h2> <p>Rake Angle: 4°</p> 		Cutting Conditions:						Coated						Uncoated											
		Continuous Cut						Medium Cut						Interrupted Cut											
  								AC810P	AC80250P	AC820P	AC830P	AC700G	YB100	AC6030M	AC630M	AC530U	AC510U	AC520U	EH520						
Sumitomo Catalog #	ISO Catalog #	I.C.	T	r	ød1																				
SNMG432EMU	SNMG120408N-MU			.0313																					
SNMG433EMU	SNMG120412N-MU	.500	.1875	.0469	.2031																				
SNMG434EMU	SNMG120416N-MU			.0625																					
SNMG543EMU	SNMG160612N-MU			.0469																					
SNMG544EMU	SNMG160616N-MU	.625	.250	.0625	.250																				
SNMG643EMU	SNMG190612N-MU			.0469																					
SNMG644EMU	SNMG190616N-MU	.750	.250	.0625	.3126																				
SNMG866EMU	SNMG250924N-MU	1.00	.375	.0938	.3622																				



SN 90° Square Type
Negative
With Insert Hole

- P** Steel
- M** Stainless Steel
- K** Cast Iron
- N** Non-ferrous
- S** Exotic Materials
- H** Hardened Steel

- USA Stocked Item
- ★ Worldwide Warehouse Item
- ▲ USA Limited Availability Item
- In stock by 1st Quarter 2017

SNMG EME		Rake Angle: 4° 	Cutting Conditions:						Coated				Uncoated						
			Continuous Cut	Medium Cut	Interrupted Cut	AC810P	AC8025P	AC820P	AC830P										
Sumitomo Catalog #	ISO Catalog #	I.C.	T	r	ød1	AC810P	AC8025P	AC820P	AC830P										
SNMG432EME	SNMG120408N-ME	.500	.1875	.0313	.2031	●	●	●	●										
SNMG433EME	SNMG120412N-ME					●	●	●	●										
SNMG434EME	SNMG120416N-ME			.0625		●	●	●	●										
SNMG543EME	SNMG150612N-ME	.625	.250	.0469	.250	●	●	●	●										
SNMG544EME	SNMG150616N-ME					●	●	●	●										
SNMG643EME	SNMG190612N-ME	.750	.3126	.0469	.3126	●	●	●	●										
SNMG644EME	SNMG190616N-ME					●	●	●	●										
SNMG866EME	SNMG250924N-ME	1.00	.375	.0938	.3622	●	●	●	●										

SNMG EMX		Rake Angle: -15° 	Cutting Conditions:						Coated				Uncoated							
			Continuous Cut	Medium Cut	Interrupted Cut	AC810P	AC0825P	AC820P	AC830P	YB100										
Sumitomo Catalog #	ISO Catalog #	I.C.	T	r	ød1	AC810P	AC0825P	AC820P	AC830P	YB100										
SNMG432EMX	SNMG120408N-MX	.500	.1875	.0313	.2031	●	●	●	●	●										
SNMG433EMX	SNMG120412N-MX					●	●	●	●											
SNMG434EMX	SNMG120416N-MX			.0625		●	●	●	●	●										
SNMG543EMX	SNMG150612N-MX	.625	.250	.0469	.250	●	●	●	●	●										
SNMG544EMX	SNMG150616N-MX					●	●	●	●											
SNMG643EMX	SNMG190612N-MX	.750	.3126	.0469	.3126	●	●	●	●	●										
SNMG644EMX	SNMG190616N-MX					●	●	●	●											



90° SQUARE TYPE

NEGATIVE INSERT

Indexable Inserts for Turning

SN

90° Square Type

Negative

With Insert Hole

- P** Steel
- M** Stainless Steel
- K** Cast Iron
- N** Non-ferrous
- S** Exotic Materials
- H** Hardened Steel

- USA Stocked Item
- ★ Worldwide Warehouse Item
- ▲ USA Limited Availability Item
- In stock by 1st Quarter 2017

Negative Inserts

C

D

R

S

T

V

W

Swiss Tooling

<h2>SNMG</h2> <h2>EGZ</h2>		Rake Angle: 0° 	Cutting Conditions:				Coated				Uncoated						
			Continuous Cut	Medium Cut	Interrupted Cut	AC405K	AC410K	AC415K	AC420K								
Sumitomo Catalog #	ISO Catalog #	I.C.	T	r	ød1	AC405K	AC410K	AC415K	AC420K								
SNMG432EGZ	SNMG120408N-GZ			.0313		●	●	●	●								
SNMG433EGZ	SNMG120412N-GZ	.500	.1875	.0469	.2031	●	▲	●	●								
SNMG434EGZ	SNMG120416N-GZ			.0625		●	●	★	●								
SNMG543EGZ	SNMG150612N-GZ	.625		.0469	.250	●	●	●	●								
SNMG643EGZ	SNMG190612N-GZ		.250	.0469		●	●	★	●								
SNMG644EGZ	SNMG190616N-GZ	.750		.0625	.3126	●	●	●	●								

<h2>SNMM</h2> <h2>ENP</h2>		Rake Angle: 0° 	Cutting Conditions:				Coated				Uncoated					
			Continuous Cut	Medium Cut	Interrupted Cut	AC810P	AC820P	AC830P								
Sumitomo Catalog #	ISO Catalog #	I.C.	T	r	ød1	AC810P	AC820P	AC830P								
SNMM643ENP	SNMM190612N-MP			.0469	.250	★	●									
SNMM644ENP	SNMM190616N-MP	.750	.250	.0625	.3126	★	●									
SNMM856ENP	SNMM250724N-MP	1.00	.3125	.0938	.3622	★	★	★								
SNMM866ENP	SNMM250924N-MP		.375	.0938		★	★									



SN 90° Square Type
Negative
With Insert Hole

- P** Steel
- M** Stainless Steel
- K** Cast Iron
- N** Non-ferrous
- S** Exotic Materials
- H** Hardened Steel

- USA Stocked Item
- ★ Worldwide Warehouse Item
- ▲ USA Limited Availability Item
- In stock by 1st Quarter 2017

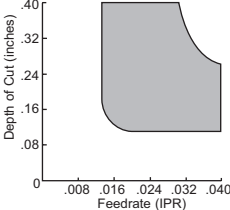
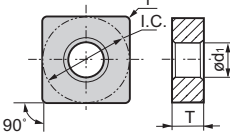
SNMM EHG		Rake Angle: 0°	Cutting Conditions:						Coated				Cermet					
			Continuous Cut	Medium Cut	Interrupted Cut													
						AC810P	AC8025P	AC820P	AC830P									
						★	●	●	●									
Sumitomo Catalog #	ISO Catalog #	I.C.	T	r	ød1	AC810P	AC8025P	AC820P	AC830P									
SNMM432EHG	SNMM120408N-HG	.500	.1875	.0313	.2031	★	●	●	●									
SNMM433EHG	SNMM120412N-HG			.0469		★	●	●	●									
SNMM434EHG	SNMM120416N-HG			.0625		★	●	●	●									
SNMM643EHG	SNMM190612N-HG			.0469	.3126	★	●	●	●									
SNMM644EHG	SNMM190616N-HG	.750	.250	.0625		●	●	●	●									
SNMM646EHG	SNMM190624N-HG			.0938		★	●	●	●									

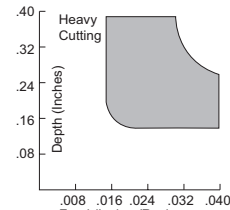
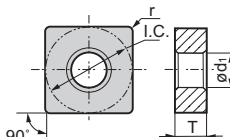
SNMM EHP		Rake Angle: 0°	Cutting Conditions:						Coated				Uncoated					
			Continuous Cut	Medium Cut	Interrupted Cut													
						AC810P	AC820P	AC830P										
						●	★	●										
Sumitomo Catalog #	ISO Catalog #	I.C.	T	r	ød1	AC810P	AC820P	AC830P										
SNMM643EHP	SNMM190612N-HP	.750	.250	.0469	.3126	●	★	●										
SNMM644EHP	SNMM190616N-HP			.0625		●	★	●										
SNMM856EHP	SNMM250724N-HP			.0938	.3622	●	★	●										
SNMM866EHP	SNMM250924N-HP	1.00	.375	.0938		●	★	●										

Negative Inserts



Swiss Tooling



90° SQUARE TYPE

NEGATIVE INSERT

Indexable Inserts for Turning

SN

90° Square Type

Negative

- P** Steel
- M** Stainless Steel
- K** Cast Iron
- N** Non-ferrous
- S** Exotic Materials
- H** Hardened Steel

- USA Stocked Item
- ★ Worldwide Warehouse Item
- ▲ USA Limited Availability Item
- In stock by 1st Quarter 2017

Negative Inserts

C

D

R

S

T

V

W

Swiss Tooling

SNMA		No Breaker	Cutting Conditions:						Coated					Uncoated				
			Continuous Cut			Medium Cut		Interrupted Cut										
									AC700G	AC405K	AC410K	AC415K	AC420K					
Sumitomo Catalog #	ISO Catalog #	I.C.	T	r	ød1							H1						
SNMA322	SNMA090308	.375	.125	.0313	.150	●	●	●	●	●	●	●	●	●	●	●		
SNMA431	SNMA120404			.0156		★	●	▲	●	●	●	●	●	●	●	●		
SNMA432	SNMA120408			.0313		●	●	▲	●	●	●	●	●	●	●	●		
SNMA433	SNMA120412	.500	.1875	.0469	.2031	●	●	●	●	●	●	●	●	●	●	●		
SNMA434	SNMA120416			.0625		●	●	▲	●	●	●	●	●	●	●	●		
SNMA435	SNMA120420			.0781		★	●	▲	●	●	●	●	●	●	●	●		
SNMA543	SNMA150612	.625		.0469	.250	●	●	●	●	●	●	●	●	●	●	●		
SNMA544	SNMA150616	.625	.250	.0625		●	●	●	●	●	●	●	●	●	●	●		
SNMA643	SNMA190612			.0469		●	●	●	●	●	●	●	●	●	●	●		
SNMA644	SNMA190616	.750		.0625	.3126	●	●	●	●	●	●	●	●	●	●	●		

SNMN		No Breaker	Cutting Conditions:						Coated		Cermet		Uncoated		
			Continuous Cut			Medium Cut		Interrupted Cut							
									AC700G	AC420K	TI 500A	TI 200A	G10E	A30	ST20E
Sumitomo Catalog #	ISO Catalog #	I.C.	T	r	ød1							G10E	A30	ST20E	
SNMN422	SNMN120308		.125	.0313		●	●	●	●	●	●	●	●	●	
SNMN432	SNMN120408	.500		.0313		★	●	●	●	●	●	●	●	●	
SNMN433	SNMN120412		.1875	.0469		★	●	●	●	●	●	●	●	●	
SNMN434	SNMN120416			.0625		★	●	●	●	●	●	●	●	●	
SNMN532	SNMN150408	.625	.1875	.0313		●	●	●	●	●	●	●	●	●	



TN



Triangular Type



Negative

With Insert Hole

- P Steel
- M Stainless Steel
- K Cast Iron
- N Non-ferrous
- S Exotic Materials
- H Hardened Steel

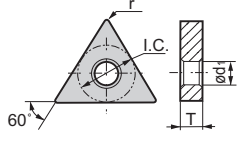
- USA Stocked Item
- ★ Worldwide Warehouse Item
- ▲ USA Limited Availability Item
- In stock by 1st Quarter 2017

TNGG		Rake Angle: 13°	Cutting Conditions:				Coated		Cermet		Uncoated	
ESU			Continuous Cut Medium Cut Interrupted Cut				●	●	●	●	●	●
		Depth (Inches) .24 .16 .08 .008 .016 .024 Feed (Inches/Rev)					T1500A					
Sumitomo Catalog #	ISO Catalog #	I.C.	T	r	ød1							
TNGG330.5ESU	TNGG160402N-SU			.0078								
TNGG331ESU	TNGG160404N-SU	.375	.1875	.0156	.150							
TNGG332ESU	TNGG160408N-SU			.0313								

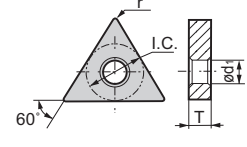
TNPR/L		Rake Angle: 14°	Cutting Conditions:				Coated		Cermet		Uncoated	
FX			Continuous Cut Medium Cut Interrupted Cut				● ○	● ○	● ○	● ○	● ○	● ○
		Depth of Cut (inches) .240 .160 .080 0 .008 .016 .024 Feedrate (IPR)					AC530U ACZ310 T1500Z T2000Z T3000Z T1500A T1200A					
Sumitomo Catalog #	ISO Catalog #	I.C.	T	r	ød1							
TNPR330.5FFX	TNGG160402R-FX			.0078								
TNPL330.5FFX	TNGG160402L-FX			.0078								
TNPR331FFX	TNGG160404R-FX	.375	.1875	.0156	.150							
TNPL331FFX	TNGG160404L-FX			.0156								

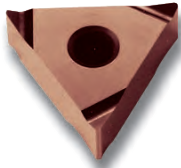
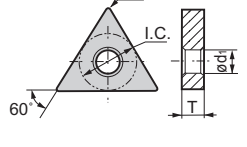
TNPR/L		Rake Angle: 15°	Cutting Conditions:				Coated		Cermet		Uncoated	
FY			Continuous Cut Medium Cut Interrupted Cut				● ○	● ○	● ○	● ○	● ○	● ○
		Depth of Cut (inches) .240 .160 .080 0 .008 .016 .024 Feedrate (IPR)					AC530U ACZ310 T1500Z T2000Z T3000Z T1500A T1200A					
Sumitomo Catalog #	ISO Catalog #	I.C.	T	r	ød1							
TNPR330.5FFY	TNGG160402R-FY			.0078								
TNPL330.5FFY	TNGG160402L-FY			.0078								
TNPR331FFY	TNGG160404R-FY	.375	.1875	.0156	.150							
TNPL331FFY	TNGG160404L-FY			.0156								



TRIANGULAR TYPE

NEGATIVE INSERT

Indexable Inserts for Turning

TN

Triangular Type

Negative

With Insert Hole

- P** Steel
- M** Stainless Steel
- K** Cast Iron
- N** Non-ferrous
- S** Exotic Materials
- H** Hardened Steel

- USA Stocked Item
- ★ Worldwide Warehouse Item
- ▲ USA Limited Availability Item
- In stock by 1st Quarter 2017

Negative Inserts

C

D

R



S



T

V

W

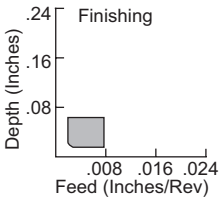
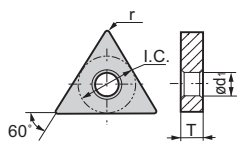
Swiss Tooling

TNP_{R/L} Q		Rake Angle: 0° 	Cutting Conditions:				Coated		Cermet		Uncoated										
			Continuous Cut	Medium Cut	Interrupted Cut																
		Finishing 							T1500A	T1200A											
Sumitomo Catalog #		ISO Catalog #	I.C.	T	r	ød1															
TNPL220.5Q		TNGG110302L-FT			.0078																
TNPR221Q		TNGG110302R-FT	.250	.125	.0156	.089															
TNPL221Q		TNGG110304L-FT			.0156																

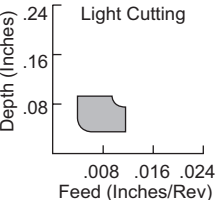
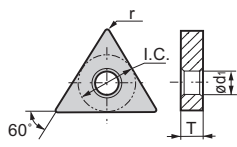
TNP_{R/L} T		Rake Angle: 0° 	Cutting Conditions:				Coated		Cermet		Uncoated										
			Continuous Cut	Medium Cut	Interrupted Cut																
		Light Cutting 							T1500A	T1200A											
Sumitomo Catalog #		ISO Catalog #	I.C.	T	r	ød1															
TNPR320.5T		TNGG160302R-ST			.0078																
TNPL320.5T		TNGG160302L-ST			.0078																
TNPR321T		TNGG160304R-ST			.0156																
TNPL321T		TNGG160304L-ST			.0156																
TNPR322T		TNGG160308R-ST			.0313																
TNPL322T		TNGG160308L-ST			.0313																





- P** Steel
- M** Stainless Steel
- K** Cast Iron
- N** Non-ferrous
- S** Exotic Materials
- H** Hardened Steel

- USA Stocked Item
- ★ Worldwide Warehouse Item
- ▲ USA Limited Availability Item
- In stock by 1st Quarter 2017

TNP_{R/L}		Rake Angle: 14°		Cutting Conditions:			Coated	Cermet					Uncoated				
M				Continuous Cut				●	●	●	●			●	●		
				Medium Cut				●	●	●	●	●	●	●	●		
				Interrupted Cut				●	●	●	●	●	●	●	●		
Sumitomo Catalog #	ISO Catalog #	I.C.	T	r	ød1		T1500Z	T2000Z	T3000Z	T1500A	T1200A	A30	G10E	H1	ST20E		
TNPR330.5M	TNGG160402R-UM	.375	.1875	.0078	.150		★		●	★	▲		●				
TNPL330.5M	TNGG160402L-UM			.0078													
TNPR331M	TNGG160404R-UM			.0156													
TNPL331M	TNGG160404L-UM			.0156													
TNPR332M	TNGG160408R-UM			.0313													
TNPL332M	TNGG160408L-UM			.0313													
TNPR333M	TNGG160412R-UM			.0469													
TNPL333M	TNGG160412L-UM			.0469													
TNPR431M	TNGG220404R-UM			.0156													
TNPL431M	TNGG220404L-UM			.0156													
TNPR432M	TNGG220408R-UM	.500		.0313	.2031		●		●	▲		★		★			
TNPL432M	TNGG220408L-UM			.0313													

TNG		No Breaker		Cutting Conditions:			Coated	Cermet					Uncoated				
—				Continuous Cut													
				Medium Cut									●				
				Interrupted Cut													
Sumitomo Catalog #	ISO Catalog #	I.C.	T	r	ød1							G10E					
TNG322	TNGN160308	.375	.125	.0313	-							●					
TNG332	TNGN160408		.1875	.0313	-							●					

- Negative Inserts
- C
- D
- R
- S
- T
- V
- W
- Swiss Tooling



TRIANGULAR TYPE

NEGATIVE INSERT

Indexable Inserts for Turning

TN

Triangular Type

Negative

With Insert Hole

- P** Steel
- M** Stainless Steel
- K** Cast Iron
- N** Non-ferrous
- S** Exotic Materials
- H** Hardened Steel

- USA Stocked Item
- ★ Worldwide Warehouse Item
- ▲ USA Limited Availability Item
- In stock by 1st Quarter 2017

Negative Inserts

C

D

R

S

T

V

W

Swiss Tooling

TNMG EFA		Rake Angle: 20°	Cutting Conditions:				Coated	Cermet			Uncoated				
			Continuous Cut					●	●	●	●				
			Medium Cut					●	●	●	●				
			Interrupted Cut						●	●	●				
								T1500Z	T2000Z	T3000Z	T1500A	T1200A			
Sumitomo Catalog #	ISO Catalog #	I.C.	T	r	ød1										
TNMG330.5EFA	TNMG160402N-FA	.375	.1875	.0078	.150		●	●	●	●	●				
TNMG331EFA	TNMG160404N-FA			.0156			●	●	●	●	●				
TNMG332EFA	TNMG160408N-FA			.0313			●	●	●	●	●				

TNMG EFL		Rake Angle: 10°	Cutting Conditions:				Coated	Cermet			Uncoated				
			Continuous Cut				●	●							
			Medium Cut				●	●	●						
			Interrupted Cut				●	●	●						
								AC8025P	AC820P	T1500Z	T2000Z	T3000Z			
Sumitomo Catalog #	ISO Catalog #	I.C.	T	r	ød1										
TNMG331EFL	TNMG160404N-FL	.375	.1875	.0156	.150		●	●	●	●	●				
TNMG332EFL	TNMG160408N-FL			.0313			●	●	●	●	●				

TNMG EFP		Rake Angle: 10°	Cutting Conditions:				Coated	Cermet			Uncoated			
			Continuous Cut					●						
			Medium Cut					●	●					
			Interrupted Cut					●	●	●				
								T1200A						
Sumitomo Catalog #	ISO Catalog #	I.C.	T	r	ød1									
TNMG322EFP	TNMG160308N-FP	.375	.125	.0313	.150		●							
TNMG332EFP	TNMG160408N-FP		.1875	.0313			●							







TN

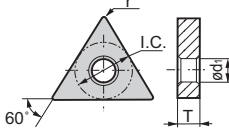

Triangular Type
Negative
With Insert Hole

- P** Steel
- M** Stainless Steel
- K** Cast Iron
- N** Non-ferrous
- S** Exotic Materials
- H** Hardened Steel

- USA Stocked Item
- ★ Worldwide Warehouse Item
- ▲ USA Limited Availability Item
- In stock by 1st Quarter 2017

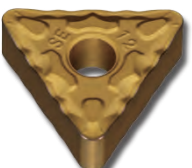
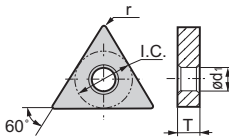
TNMG ESU		Rake Angle: 13°		Cutting Conditions:		Coated						Cermet					
				Continuous Cut		Medium Cut		Interrupted Cut									
		Depth (Inches) Feed (Inches/Rev)															
Sumitomo Catalog #		ISO Catalog #		I.C.		T		r		ød1							
TNMG321ESU		TNMG160304N-SU		.125		.0156		.0313		.150							
TNMG322ESU		TNMG160308N-SU		.375		.0156		.0313		.150							
TNMG331ESU		TNMG160404N-SU		.1875		.0469		.0156		.2031							
TNMG332ESU		TNMG160408N-SU		.500		.0313		.0469		.2031							
TNMG333ESU		TNMG160412N-SU		.500		.0313		.0469		.2031							
TNMG431ESU		TNMG220404N-SU		.500		.0313		.0469		.2031							
TNMG432ESU		TNMG220408N-SU		.500		.0313		.0469		.2031							
TNMG433ESU		TNMG220412N-SU		.500		.0313		.0469		.2031							

TNMG ESE		Rake Angle: 5°		Cutting Conditions:		Coated						Cermet					
				Continuous Cut		Medium Cut		Interrupted Cut									
		Depth (Inches) Feedrate (IPR)															
Sumitomo Catalog #		ISO Catalog #		I.C.		T		r		ød1							
TNMG331 ESE		TNMG160404N-SE		.375		.0156		.0313		.150							
TNMG332 ESE		TNMG160408N-SE		.1875		.0469		.0156		.2031							
TNMG333 ESE		TNMG160412N-SE		.500		.0313		.0469		.2031							
TNMG431 ESE		TNMG220404N-SE		.500		.0313		.0469		.2031							
TNMG432 ESE		TNMG220408N-SE		.500		.0313		.0469		.2031							
TNMG433 ESE		TNMG220412N-SE		.500		.0313		.0469		.2031							

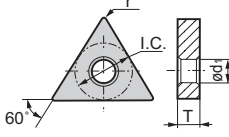
TNMG ELU		Rake Angle: 10°		Cutting Conditions:		Coated			Cermet			Uncoated					
				Continuous Cut		Medium Cut		Interrupted Cut									
		Depth of Cut (Inches) Feedrate (IPR)															
Sumitomo Catalog #		ISO Catalog #		I.C.		T		r		ød1							
TNMG331ELU		TNMG160404N-LU		.375		.1875		.0156		.150							
TNMG332ELU		TNMG160408N-LU		.1875		.0469		.0156		.2031							
TNMG333ELU		TNMG160412N-LU		.500		.0313		.0469		.2031							

Negative Inserts

C

D

R

S

T

V

W

Swiss Tooling



TRIANGULAR TYPE

NEGATIVE INSERT

Indexable Inserts for Turning

TN

Triangular Type

Negative

With Insert Hole

- P** Steel
- M** Stainless Steel
- K** Cast Iron
- N** Non-ferrous
- S** Exotic Materials
- H** Hardened Steel

- USA Stocked Item
- ★ Worldwide Warehouse Item
- ▲ USA Limited Availability Item
- In stock by 1st Quarter 2017

Negative Inserts

C

D

R

S

T

V

W

Swiss Tooling

TNMG ENK

Rake Angle: 10°



Cutting Conditions:

Continuous Cut

Medium Cut

Interrupted Cut

Coated	Cermet	Uncoated
●	●	
●	●	
●	●	

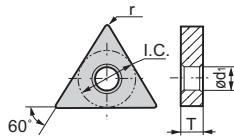
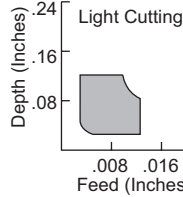

AC820P

T1200A

Sumitomo Catalog #

ISO Catalog #

I.C.

T

r

ød1

AC820P

T1200A

Sumitomo Catalog #	ISO Catalog #	I.C.	T	r	ød1	AC820P	T1200A						
TNMG221ENK	TNMG110304N-SK	.250		.0156	.089	●							
TNMG321ENK	TNMG160304N-SK		.125	.0156									
TNMG322ENK	TNMG160308N-SK			.0313									
TNMG331ENK	TNMG160404N-SK	.375		.0156	.150	●	▲						
TNMG332ENK	TNMG160408N-SK			.0313									
TNMG431ENK	TNMG220404N-SK		.1875	.0156		●	▲						
TNMG432ENK	TNMG220408N-SK	.500		.0313	.2031	●	▲						

TNMG FNJ

Rake Angle: 0°



Cutting Conditions:

Continuous Cut

Medium Cut

Interrupted Cut

Coated	Cermet	Uncoated
		●

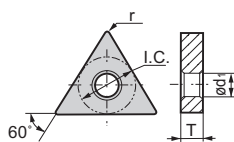
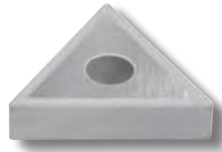

G10E

Sumitomo Catalog #

ISO Catalog #

I.C.

T

r

ød1

Sumitomo Catalog #	ISO Catalog #	I.C.	T	r	ød1	G10E
TNMG431FNJ	TNMG220404N-UJ	.500	.1875	.0156	.2031	●

TNMG EEF

Rake Angle: 20°



Cutting Conditions:

Continuous Cut

Medium Cut

Interrupted Cut

Coated	Cermet	Uncoated
●		●
●		●
●		●

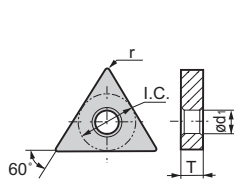
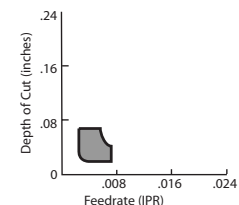

AC6020M

AC6030M

AC6040M

AC630M

AC510U

AC520U

EH510

EH520

Sumitomo Catalog #	ISO Catalog #	I.C.	T	r	ød1	AC6020M	AC6030M	AC6040M	AC630M	AC510U	AC520U	EH510	EH520
TNMG331EEF	TNMG160404N-EF	.375	.1875	.0156	.150	○	●	●	●	●	●	●	●
TNMG332EEF	TNMG160408N-EF			.0313		○	●	●	●	●	●	●	●



TN

Triangular Type

Negative

With Insert Hole

- P Steel
- M Stainless Steel
- K Cast Iron
- N Non-ferrous
- S Exotic Materials
- H Hardened Steel

- USA Stocked Item
- ★ Worldwide Warehouse Item
- ▲ USA Limited Availability Item
- In stock by 1st Quarter 2017

TNMG ESX		Rake Angle: 3°	Cutting Conditions:				Coated		Cermet		Uncoated				
Sumitomo Catalog #	ISO Catalog #	I.C.	T	r	ød1	AC810P	AC8025P	AC820P	AC830P	AC700G	T1500Z	T2000Z	T3000Z	T1500A	T1200A
TNMG321ESX	TNMG160304N-SX		.125	.0156		●	●	●	●	●	●	●	●	●	●
TNMG322ESX	TNMG160308N-SX			.0313		●	●	●	●	●	●	●	●	●	●
TNMG331ESX	TNMG160404N-SX	.375		.0156	.150	●	●	●	●	●	●	●	●	●	●
TNMG332ESX	TNMG160408N-SX			.0313		●	●	●	●	●	●	●	●	●	●
TNMG431ESX	TNMG220404N-SX		.1875	.0156		●	●	●	●	●	●	●	●	●	●
TNMG432ESX	TNMG220408N-SX	.500		.0313	.2031	●	●	●	●	●	●	●	●	●	●
TNMG433ESX	TNMG220412N-SX			.0469		●	●	●	●	●	●	●	●	●	●

TNMG EUP		Rake Angle: 10°	Cutting Conditions:				Coated						Uncoated		
Sumitomo Catalog #	ISO Catalog #	I.C.	T	r	ød1	AC8025P	AC820P	AC830P	AC6030M	AC6040M	AC630M	AC530U	AC510U	AC520U	G10E
TNMG331EUP	TNMG160404N-UP			.0156		●	●	●	●	●	●	●	●	●	●
TNMG332EUP	TNMG160408N-UP	.375		.0313	.150	●	●	●	●	●	●	●	●	●	●
TNMG333EUP	TNMG160412N-UP		.1875	.0469		●	●	●	●	●	●	●	●	●	●
TNMG432EUP	TNMG220408N-UP			.0313		●	●	●	●	●	●	●	●	●	●
TNMG433EUP	TNMG220412N-UP	.500		.0469	.2031	●	●	●	●	●	●	●	●	●	●

TNMG EEG		Rake Angle: 0°	Cutting Conditions:				Coated				Cermet		Uncoated	
Sumitomo Catalog #	ISO Catalog #	I.C.	T	r	ød1	AC8025P	AC6020M	AC6030M	AC6040M	AC630M	AC510U	AC520U	EH510	EH520
TNMG331EEG	TNMG160404N-EG			.0156		●	○	●	●	●	●	●	●	●
TNMG332EEG	TNMG160408N-EG	.375	.1875	.0313	.150	●	○	●	●	●	●	●	●	●
TNMG333EEG	TNMG160412N-EG			.0469		●	○	●	●	●	●	●	●	●



TRIANGULAR TYPE

NEGATIVE INSERT

Indexable Inserts for Turning

TN

Triangular Type

Negative

With Insert Hole

- P** Steel
- M** Stainless Steel
- K** Cast Iron
- N** Non-ferrous
- S** Exotic Materials
- H** Hardened Steel

- USA Stocked Item
- ★ Worldwide Warehouse Item
- ▲ USA Limited Availability Item
- In stock by 1st Quarter 2017

Negative Inserts

C

D

R

S

T

V

W

Swiss Tooling

TNMG EEM		Rake Angle: 0°	Cutting Conditions:					Coated		Cermet		Uncoated	
			Continuous Cut		●	●	●	●					
			Medium Cut		●	●	●	●					
			Interrupted Cut		●	●	●	●					
Sumitomo Catalog #	ISO Catalog #	I.C.	T	r	ød1	AC8025P	AC6020M	AC6030M	AC6040M	AC520U			
TNMG332EEM	TNMG160408N-EM	.375	.1875	.0313	.150	●	○	●	●				
TNMG333EEM	TNMG160412N-EM			.0469									
TNMG666EEM	TNMG330924N-EM	.750	.375	.0938	.3126								

TNMG EMU		Rake Angle: 4°	Cutting Conditions:					Coated						Uncoated			
			Continuous Cut		●	●	●	●	●	●	●	●	●	●	●		
			Medium Cut		●	●	●	●	●	●	●	●	●	●	●		
			Interrupted Cut		●	●	●	●	●	●	●	●	●	●	●		
Sumitomo Catalog #	ISO Catalog #	I.C.	T	r	ød1	AC810P	AC8025P	AC820P	AC830P	AC700G	YB100	AC6030M	AC6040M	AC630M	AC530U	AC510U	AC520U
TNMG332EMU	TNMG160408N-MU	.375		.0313	.150	●	●	●	●	●		●	●	●	★	●	●
TNMG333EMU	TNMG160412N-MU			.0469		●	●	●	●	●		●	●	●	★	●	●
TNMG432EMU	TNMG220408N-MU		.1875	.0313		●	●	●	●	●		●	●	●		●	●
TNMG433EMU	TNMG220412N-MU	.500		.0469	.2031	●	●	●	●	●		●	●	●		●	●
TNMG434EMU	TNMG220416N-MU			.0625		●	●	●	●	●		●	●	●		●	●
TNMG543EMU	TNMG270612N-MU	.625	.250	.0469	.250	▲	●	●	●	●		●	●	●		●	●
TNMG544EMU	TNMG270616N-MU			.0625		▲	●	●	●	●	▲						

TNMG EME		Rake Angle: 4°	Cutting Conditions:					Coated						Uncoated	
			Continuous Cut		●	●	●								
			Medium Cut		●	●	●	●							
			Interrupted Cut		●	●	●								
Sumitomo Catalog #	ISO Catalog #	I.C.	T	r	ød1	AC810P	AC8025P	AC820P	AC830P						
TNMG332EME	TNMG160408N-ME	.375		.0313	.150	●	●	●	●						
TNMG333EME	TNMG160412N-ME			.0469		●	●	●	●						
TNMG432EME	TNMG220408N-ME		.1875	.0313		●	●	●	●						
TNMG433EME	TNMG220412N-ME	.500		.0469	.2031	●	●	●	●						
TNMG434EME	TNMG220416N-ME			.0625		●	●	●	●						



TN

Triangular Type
Negative
With Insert Hole

- P** Steel
- M** Stainless Steel
- K** Cast Iron
- N** Non-ferrous
- S** Exotic Materials
- H** Hardened Steel

- USA Stocked Item
- ★ Worldwide Warehouse Item
- ▲ USA Limited Availability Item
- In stock by 1st Quarter 2017

Negative Inserts



Swiss Tooling

TNMG EEX		Rake Angle: 16°	Cutting Conditions:				Coated						Uncoated					
Sumitomo Catalog #	ISO Catalog #	I.C.	T	r	ød1	AC610M	AC6020M	AC6030M	AC6040M	AC630M	AC530U	AC510U	AC520U	EH510				
TNMG331EEX	TNMG160404N-EX		.1875	.0156	.150	●	○	●	●	●	★	●	●	★				
TNMG332EEX	TNMG160408N-EX	.375		.0313		○	○	○	○	○	○	○	○					
TNMG333EEX	TNMG160412N-EX			.0469		★	○	●	●	★	★	★						

TNMG EGU		Rake Angle: 7°	Cutting Conditions:				Coated						Cermet					
Sumitomo Catalog #	ISO Catalog #	I.C.	T	r	ød1	AC810P	AC8025P	AC820P	AC830P	AC700G	YB100	AC610M	AC6020M	AC6030M	AC630M	AC530U	T1500A	T1200A
TNMG331EGU	TNMG160404N-GU			.0156	.150	●	●	●	●	●	○	★	○	●	●	★	★	
TNMG332EGU	TNMG160408N-GU	.375		.0313		●	●	●	●	●	○	●	○	●	●	★	●	▲
TNMG333EGU	TNMG160412N-GU			.0469		●	●	●	●	●	○	●	○	●	●	★		
TNMG334EGU	TNMG160416N-GU		.1875	.0625		●	●	★	★			○	○	●	●	★		
TNMG431EGU	TNMG220404N-GU			.0156	.2031	●	●			●								
TNMG432EGU	TNMG220408N-GU	.500		.0313		●	●			●								
TNMG433EGU	TNMG220412N-GU			.0469		●	●			●								

TNMG EGE		Rake Angle: 3°	Cutting Conditions:				Coated						Uncoated					
Sumitomo Catalog #	ISO Catalog #	I.C.	T	r	ød1	AC810P	AC8025P	AC820P	AC830P	AC700G								
TNMG331EGE	TNMG160404N-GE			.0156	.150	●	●	●	●									
TNMG332EGE	TNMG160408N-GE	.375		.0313		●	●	●	●									
TNMG333EGE	TNMG160412N-GE		.1875	.0469		●	●	●	●									
TNMG432EGE	TNMG220408N-GE	.500		.0313	.2031	●	●	●	●									
TNMG433EGE	TNMG220412N-GE			.0469		●	●											



TRIANGULAR TYPE

NEGATIVE INSERT

Indexable Inserts for Turning

TN

Triangular Type

Negative

With Insert Hole

- P** Steel
- M** Stainless Steel
- K** Cast Iron
- N** Non-ferrous
- S** Exotic Materials
- H** Hardened Steel

- USA Stocked Item
- ★ Worldwide Warehouse Item
- ▲ USA Limited Availability Item
- In stock by 1st Quarter 2017

Negative Inserts

C

D

R



S



T

V

W

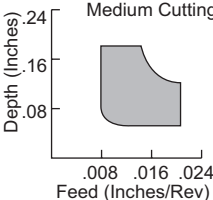
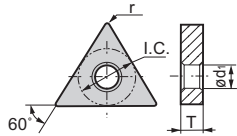
Swiss Tooling

TNMG EUX		Rake Angle: 0° 	Cutting Conditions:						Coated				Cermet						
			Continuous Cut	Medium Cut	Interrupted Cut	AC810P	AC8025P	AC820P	AC830P	AC700G	AC410K	T1500A	T1200A						
																			
Sumitomo Catalog #	ISO Catalog #	I.C.	T	r	ød1														
TNMG321EUX	TNMG160304N-UX	.375	.125	.0156	.150	●	●	●	●	●									
TNMG322EUX	TNMG160308N-UX			.0313		●	●	●	●										
TNMG331EUX	TNMG160404N-UX			.0156		●	●	●	●	●	▲								
TNMG332EUX	TNMG160408N-UX			.0313		●	●	●	●	●									
TNMG333EUX	TNMG160412N-UX		.1875	.0469		●	●	●	●	●									
TNMG432EUX	TNMG220408N-UX			.0313		●	●	●	●	●									
TNMG433EUX	TNMG220412N-UX	.500		.0469	.2031	●	●	●	●	●									

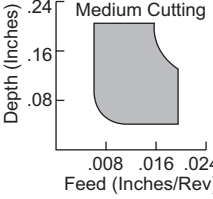
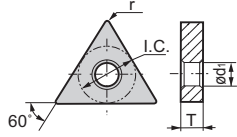
TNMG ENG		Rake Angle: 4° 	Cutting Conditions:						Coated				Cermet						
			Continuous Cut	Medium Cut	Interrupted Cut	AC8025P	AC820P	AC830P	AC700G	T1200A									
																			
Sumitomo Catalog #	ISO Catalog #	I.C.	T	r	ød1														
TNMG321ENG	TNMG160304N-UG	.375	.125	.0156	.150	●	●	●	●										
TNMG322ENG	TNMG160308N-UG			.0313		●	●	●	●										
TNMG331ENG	TNMG160404N-UG			.0156		★	★	●	●	●	●								
TNMG332ENG	TNMG160408N-UG			.0313		●	●	●	●	●									
TNMG333ENG	TNMG160412N-UG		.1875	.0469		●	●	●	●	●									
TNMG334ENG	TNMG160416N-UG			.0625		●	●	●	●	●									
TNMG432ENG	TNMG220408N-UG			.0313		●	●	●	●	●									
TNMG433ENG	TNMG220412N-UG	.500		.0469	.2031	●	●	●	●	●									
TNMG434ENG	TNMG220416N-UG			.0625		●	●	●	●	●									
TNMG542ENG	TNMG270608N-UG			.0313		●	●	●	●	●									
TNMG543ENG	TNMG270612N-UG	.625	.250	.0469	.250	●	●	●	●	●									
TNMG544ENG	TNMG270616N-UG			.0625		●	●	●	●	●									
TNMG666ENG	TNMG330924N-UG	.750	.375	.0938	.3126	●	●	●	●	●									



TN

Triangular Type

Negative

With Insert Hole

- P Steel
- M Stainless Steel
- K Cast Iron
- N Non-ferrous
- S Exotic Materials
- H Hardened Steel

- USA Stocked Item
- ★ Worldwide Warehouse Item
- ▲ USA Limited Availability Item
- In stock by 1st Quarter 2017

TNMG ENZ/FNZ		Rake Angle: 4°	Cutting Conditions:						Coated						Uncoated						
Sumitomo Catalog #	ISO Catalog #	I.C.	T	r	ød1	AC8025P	AC820P	AC830P	AC700G	AC405K	AC415K	AC420K	G10E								
TNMG322 ENZ	TNMG160308N-UZ	.375	.125	.0313	.150	●	●	●	●	●	●	●									
TNMG323 ENZ	TNMG160312N-UZ					●	●	●	●	●	●	●	●	●							
TNMG331 ENZ	TNMG160404N-UZ					●	●	●	●	●	●	●	●	●	●						
TNMG332 ENZ	TNMG160408N-UZ	.1875	.125	.0313	.150	●	●	●	●	●	●	●									
TNMG333 ENZ	TNMG160412N-UZ					●	●	●	●	●	●	●	●	●							
TNMG334 ENZ	TNMG160416N-UZ					●	●	●	●	●	●	●	●	●	●						
TNMG335 ENZ	TNMG160420N-UZ	.500	.125	.0781	.2031	●	●	●	●	●	●	●									
TNMG432 ENZ	TNMG220408N-UZ					●	●	●	●	●	●	●	●	●	●						
TNMG433 ENZ	TNMG220412N-UZ					●	●	●	●	●	●	●	●	●	●						
TNMG434 ENZ	TNMG220416N-UZ	.625	.250	.0625	.250	●	●	●	●	●	●	●									
TNMG542 ENZ	TNMG270608N-UZ					●	●	●	●	●	●	●	●	●	●						
TNMG543 ENZ	TNMG270612N-UZ					●	●	●	●	●	●	●	●	●	●						
TNMG544 ENZ	TNMG270616N-UZ	.750	.375	.125	.250	●	●	●	●	●	●	●									
TNMG548 ENZ	TNMG270632N-UZ					●	●	●	●	●	●	●	●	●	●						
TNMG666 ENZ	TNMG330924N-UZ					●	●	●	●	●	●	●	●	●	●						
TNMG432 FNZ	TNMG220408N-UZ	.500	.1875	.0313	.2031	●	●	●	●	●	●	●	●								

TNMG EMX		Rake Angle: -15°	Cutting Conditions:						Coated						Uncoated					
Sumitomo Catalog #	ISO Catalog #	I.C.	T	r	ød1	AC8025P	AC820P	AC830P												
TNMG332 EMX	TNMG160408N-MX	.375	.1875	.0313	.150	●	●	●												
TNMG333 EMX	TNMG160412N-MX					●	●	●												
TNMG432 EMX	TNMG220408N-MX					●	●	●												
TNMG433 EMX	TNMG220412N-MX	.500	.1875	.0469	.2031	●	●	●												

Negative Inserts

C

D

R

S

T

V

W

Swiss Tooling



TRIANGULAR TYPE

NEGATIVE INSERT

Indexable Inserts for Turning

TN

Triangular Type

Negative

With Insert Hole

- P** Steel
- M** Stainless Steel
- K** Cast Iron
- N** Non-ferrous
- S** Exotic Materials
- H** Hardened Steel

- USA Stocked Item
- ★ Worldwide Warehouse Item
- ▲ USA Limited Availability Item
- In stock by 1st Quarter 2017

Negative Inserts

C

D

R



S



T

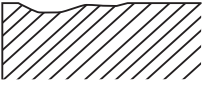

V

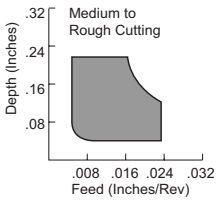
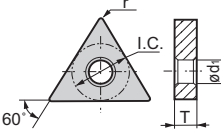
W

Swiss Tooling

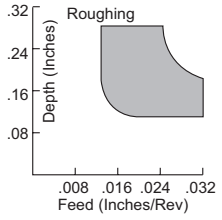
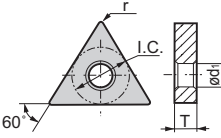
TNMG EGZ		Rake Angle: 0° 	Cutting Conditions:					Coated		Cermet		Uncoated	
			Continuous Cut	Medium Cut	Interrupted Cut	●	●						
					AC405K		AC415K		AC420K				
Sumitomo Catalog #	ISO Catalog #	I.C.	T	r	ød1	●	●	●					
TNMG331EGZ	TNMG160404N-GZ			.0156		●	●	●					
TNMG332EGZ	TNMG160408N-GZ	.375		.0313	.150	●	●	●					
TNMG333EGZ	TNMG160412N-GZ		.1875	.0469		●	●	●					
TNMG432EGZ	TNMG220408N-GZ			.0313	.2031	★	★	●					
TNMG433EGZ	TNMG220412N-GZ	.500		.0469		★	★	●					

TNMM ENP		Rake Angle: 0° 	Cutting Conditions:					Coated		Uncoated		
			Continuous Cut	Medium Cut	Interrupted Cut	●	●					
					AC810P		AC820P		AC830P			
Sumitomo Catalog #	ISO Catalog #	I.C.	T	r	ød1	★	★	●				
TNMM332ENP	TNMM160408N-MP	.375	.1875	.0313	.150	★	★	●				

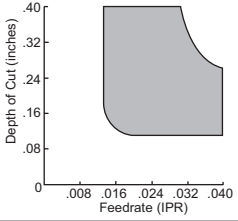
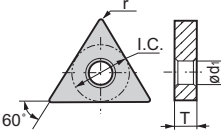
TNMM EHG		Rake Angle: 0° 	Cutting Conditions:					Coated		Cermet		
			Continuous Cut	Medium Cut	Interrupted Cut	●	●					
					AC810P		AC8025P		AC820P		AC830P	
Sumitomo Catalog #	ISO Catalog #	I.C.	T	r	ød1	★	●	●	●	★		
TNMM432EHG	TNMM220408N-HG			.0313		★	●	●	●	★		
TNMM433EHG	TNMM220412N-HG	.500	.1875	.0469	.2031	★	●	●	●	★		
TNMM434EHG	TNMM220416N-HG			.0625		★	●	●	●	★		



TRIANGULAR TYPE NEGATIVE INSERT



TN

Triangular Type

Negative

- P Steel
- M Stainless Steel
- K Cast Iron
- N Non-ferrous
- S Exotic Materials
- H Hardened Steel

- USA Stocked Item
- ★ Worldwide Warehouse Item
- ▲ USA Limited Availability Item
- In stock by 1st Quarter 2017

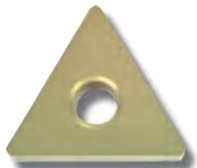
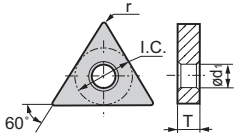
TNMA		No Breaker	Cutting Conditions:						Coated					Uncoated				
—			Continuous Cut						●	●	●	●	●	●	●	●	●	●
—			Medium Cut						●	●	●	●	●	●	●	●	●	●
—			Interrupted Cut						●	●	●	●	●	●	●	●	●	●
		—							AC700G	AC405K	AC410K	AC415K	AC420K	G10E	H1			
Sumitomo Catalog #	ISO Catalog #	I.C.	T	r	ød1	AC700G	AC405K	AC410K	AC415K	AC420K	G10E	H1						
TNMA322	TNMA160308	.375	.125	.0313	.150	●	●	●	●	●	●	●						
TNMA331	TNMA160404		.0156	●		●	●	●	●	●	●	●	●	●	●	●	●	●
TNMA332	TNMA160408	.375	.0313	●	.150	●	●	●	●	●	●	●	●	●	●	●	●	●
TNMA333	TNMA160412		.0469	●		●	●	●	●	●	●	●	●	●	●	●	●	●
TNMA334	TNMA160416	.375	.0625	●	.150	●	●	●	●	●	●	●	●	●	●	●	●	●
TNMA335	TNMA160420		.0781	●		●	●	●	●	●	●	●	●	●	●	●	●	●
TNMA431	TNMA220404	.500	.1875	.0156	.2031	●	●	●	●	●	●	●	●	●	●	●	●	●
TNMA432	TNMA220408		.0313	●		●	●	●	●	●	●	●	●	●	●	●	●	●
TNMA433	TNMA220412	.500	.0469	●	.2031	●	●	●	●	●	●	●	●	●	●	●	●	●
TNMA434	TNMA220416		.0625	●		●	●	●	●	●	●	●	●	●	●	●	●	●
TNMA438	TNMA220432	.625	.125	●	.250	●	●	●	●	●	●	●	●	●	●	●	●	●
TNMA543	TNMA270612		.0469	●		●	●	●	●	●	●	●	●	●	●	●	●	●
TNMA544	TNMA270616	.625	.250	.0625	.250	●	●	●	●	●	●	●	●	●	●	●	●	●

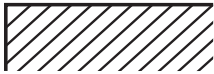
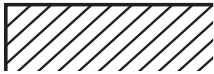
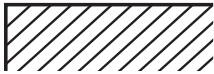
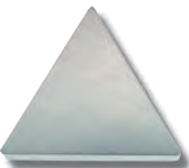
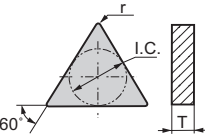
TNMN		No Breaker	Cutting Conditions:						Coated					Cermet						
—			Continuous Cut						●											
—			Medium Cut						●	●										
—			Interrupted Cut						●	●										
		—							AC700G	AC420K										
Sumitomo Catalog #	ISO Catalog #	I.C.	T	r	ød1	AC700G	AC420K													
TNMN332	TNMN160408	.375	.1875	.0313	-	●	●													
TNMN333	TNMN160412			.0469		●	●													
TNMN334	TNMN160416	.375	.1875	.0625	-	●	●													
TNMN432	TNMN220408			.0313		●	●													

Negative Inserts



Swiss Tooling



TRIANGULAR TYPE

NEGATIVE INSERT

Indexable Inserts for Turning

TRM

T-Rex Type

Negative

With Insert Hole

- P** Steel
- M** Stainless Steel
- K** Cast Iron
- N** Non-ferrous
- S** Exotic Materials
- H** Hardened Steel

- USA Stocked Item
- ★ Worldwide Warehouse Item
- ▲ USA Limited Availability Item
- In stock by 1st Quarter 2017

Negative Inserts

C

D

R

S

T

V

W

Swiss Tooling

TRM GU		Rake Angle: 7° 	Cutting Conditions:						Coated			Cermet			Uncoated		
			Continuous Cut	Medium Cut	Interrupted Cut	●	●	●	●	●	●	●	●	●	●	●	●
Sumitomo Catalog #	ISO Catalog #	I.C.	T	r	ød1	AC810P	AC8025P	AC820P	AC830P	AC700G	AC610M	AC6030M	AC630M				
TRM551704GU	TRM551704-GU	.394	.197	.0156	.084	★	●	●	●	●	●	●	●				
TRM551708GU	TRM551708-GU			.0313		★	●	●	●	●	●	●	●				
TRM551712GU	TRM551712-GU			.0469		★	●	●	●	●	●	●	●				

TRM SU		Rake Angle: 13° 	Cutting Conditions:						Coated			Cermet			Uncoated		
			Continuous Cut	Medium Cut	Interrupted Cut	●	●	●	●	●	●	●	●	●	●	●	
Sumitomo Catalog #	ISO Catalog #	I.C.	T	r	ød1	AC8025P	AC610M	AC6030M	AC630M								
TRM551704SU	TRM551704-SU	.394	.197	.0156	.084	●	●	●	●								
TRM551708SU	TRM551708-SU			.0313		●	●	●	●								
TRM551712SU	TRM551712-SU			.0469		●	●	●	●								

TRM LU		Rake Angle: 10° 	Cutting Conditions:						Coated			Cermet			Uncoated		
			Continuous Cut	Medium Cut	Interrupted Cut	●	●	●	●	●	●	●	●	●	●	●	
Sumitomo Catalog #	ISO Catalog #	I.C.	T	r	ød1	AC810P	AC8025P	AC820P	AC830P	AC700G		T2000Z					
TRM551704LU	TRM551704-LU	.394	.197	.0156	.084	★	●	●	●	●	●	●					
TRM551708LU	TRM551708-LU			.0313		★	●	●	●	●	●	●					
TRM551712LU	TRM551712-LU			.0469		★	●	●	●	●	●	●					



VN

35° Diamond Type

Negative

With Insert Hole

- P** Steel
- M** Stainless Steel
- K** Cast Iron
- N** Non-ferrous
- S** Exotic Materials
- H** Hardened Steel

- USA Stocked Item
- ★ Worldwide Warehouse Item
- ▲ USA Limited Availability Item
- In stock by 1st Quarter 2017

VNGG ESU		Rake Angle: 13°		Cutting Conditions:		Coated		Cermet		Uncoated							
						Continuous Cut		Medium Cut		Interrupted Cut							
		Light Cutting Depth (Inches) .24 .16 .08 .008 .016 .024 Feed (Inches/Rev)				AC520U		T1500Z		T2000Z		T3000Z		T1500A		H1	
								Sumitomo Catalog #		ISO Catalog #		I.C.		T		r	
VNGG330ESU		VNGG160401N-SU		.375		.1875		.0039		.150							
VNGG330ESUJ		VNGG160401N-SUJ															
VNGG330.5ESU		VNGG160402N-SU															
VNGG330.5ESUJ		VNGG160402N-SUJ															
VNGG331ESU		VNGG160404N-SU															
VNGG331ESUJ		VNGG160404N-SUJ															
VNGG332ESU		VNGG160408N-SU															
VNGG332ESUJ		VNGG160408N-SUJ															

J in ESUJ = J Polish

VNGG EEF		Rake Angle: 20°		Cutting Conditions:		Coated		Uncoated					
						Continuous Cut		Medium Cut		Interrupted Cut			
		Depth of Cut (Inches) .24 .16 .08 .008 .016 .024 Feedrate (IPR)				AC520U							
								Sumitomo Catalog #		ISO Catalog #		I.C.	
VNGG330.5EEF		VNGG160402N-EF		.375		.1875		.0078		.150			

VNMG ESU		Rake Angle: 13°		Cutting Conditions:		Coated		Cermet		UC																																	
						Continuous Cut		Medium Cut		Interrupted Cut																																	
		Light Cutting Depth (Inches) .24 .16 .08 .008 .016 .024 Feed (Inches/Rev)				AC810P		AC8025P		AC820P		AC830P		AC700G		YB100		AC6030M		AC6040M		AC630M		AC530U		AC510U		AC520U		T1500Z		T2000Z		T3000Z		T1500A		T1200A		EH510		EH520	
								Sumitomo Catalog #		ISO Catalog #		I.C.		T		r		ød1																									
VNMG331ESU		VNMG160404N-SU		.375		.1875		.0156		.150																																	
VNMG332ESU		VNMG160408N-SU																																									



Negative Inserts



Swiss Tooling

35° DIAMOND TYPE

NEGATIVE INSERT

Indexable Inserts for Turning

VN

35° Diamond Type

Negative

With Insert Hole

- P** Steel
- M** Stainless Steel
- K** Cast Iron
- N** Non-ferrous
- S** Exotic Materials
- H** Hardened Steel

- USA Stocked Item
- ★ Worldwide Warehouse Item
- ▲ USA Limited Availability Item
- In stock by 1st Quarter 2017

Negative Inserts

C

D

R

S

T

V

W

Swiss Tooling

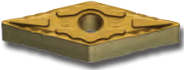
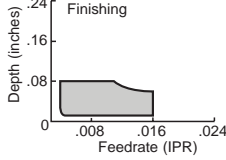
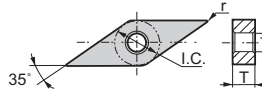
VNMG ESE		Rake Angle: 5°	Cutting Conditions:						Coated				Cermet		Uncoated	
			Continuous Cut	Medium Cut	Interrupted Cut	AC810P	AC8025P	AC820P	AC830P	T1500Z	T2000Z	T3000Z	T1500A	T1200A		
  		Sumitomo Catalog #	ISO Catalog #	I.C.	T	r	ød1	AC810P	AC8025P	AC820P	AC830P	T1500Z	T2000Z	T3000Z	T1500A	T1200A
		VNMG331ESE	VNMG160404N-SE	.375	.1875	.0156	.150	●	●	●	●	●	●	●	●	●

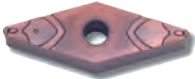
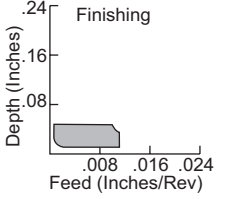
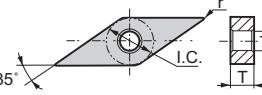
VNMG EFA		Rake Angle: 20°	Cutting Conditions:						Coated		Cermet				Uncoated	
			Continuous Cut	Medium Cut	Interrupted Cut	T1500Z	T2000Z	T3000Z	T1500A	T1200A						
  		Sumitomo Catalog #	ISO Catalog #	I.C.	T	r	ød1	T1500Z	T2000Z	T3000Z	T1500A	T1200A				
		VNMG331EFA	VNMG160404N-FA	.375	.1875	.0156	.150	●	●	●	●	●	●			

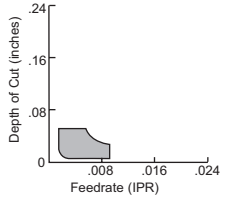
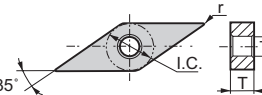
VNMG EFL		Rake Angle: 10°	Cutting Conditions:						Coated		Cermet				Uncoated	
			Continuous Cut	Medium Cut	Interrupted Cut	AC810P	AC8025P	AC820P	T1500Z	T2000Z	T3000Z					
  		Sumitomo Catalog #	ISO Catalog #	I.C.	T	r	ød1	AC810P	AC8025P	AC820P	T1500Z	T2000Z	T3000Z			
		VNMG331EFL	VNMG160404N-FL	.375	.1875	.0156	.150	●	●	●	●	●	●	●		



VN

35° Diamond Type

Negative

With Insert Hole

- P** Steel
- M** Stainless Steel
- K** Cast Iron
- N** Non-ferrous
- S** Exotic Materials
- H** Hardened Steel

- USA Stocked Item
- ★ Worldwide Warehouse Item
- ▲ USA Limited Availability Item
- In stock by 1st Quarter 2017

VNMG EFP		Rake Angle: 10° 	Cutting Conditions:						Coated		Cermet		Uncoated	
			Continuous Cut						●	●	●	●		
Medium Cut						●	●	●	●					
Interrupted Cut						●	●	●	●					
		Finishing Depth (Inches) .24 .16 .08 .008 .016 .024 Feed (Inches/Rev)						T1200A ▲						
Sumitomo Catalog #	ISO Catalog #	I.C.	T	r	ød1									
VNMG331EFP	VNMG160404N-FP	.375	.1875	.0156	.150									
VNMG332EFP	VNMG160408N-FP			.0313										

VNMG ELU		Rake Angle: 10° 	Cutting Conditions:						Coated		Cermet		Uncoated	
			Continuous Cut						●	●	●	●		
Medium Cut						●	●	●	●	●	●			
Interrupted Cut						●	●	●	●	●	●			
		Depth of Cut (Inches) .24 .16 .08 0 .008 .016 .024 Feedrate (IPR)						AC810P AC8025P AC820P AC700G T1500Z T2000Z T3000Z T1500A						
Sumitomo Catalog #	ISO Catalog #	I.C.	T	r	ød1									
VNMG331ELU	VNMG160404N-LU			.0156										
VNMG332ELU	VNMG160408N-LU	.375	.1875	.0313	.150									
VNMG333ELU	VNMG160412N-LU			.0469										

VNMG EEF		Rake Angle: 20° 	Cutting Conditions:						Coated		Cermet		Uncoated	
			Continuous Cut						●	●	●	●	●	●
Medium Cut						●	●	●	●	●	●	●	●	
Interrupted Cut						●	●	●	●	●	●	●	●	
		Depth of Cut (Inches) .24 .16 .08 0 .008 .016 .024 Feedrate (IPR)						AC6020M AC6030M AC6040M AC630M AC510U AC520U EH510 EH520						
Sumitomo Catalog #	ISO Catalog #	I.C.	T	r	ød1									
VNMG330.5EEF	VNMG160402N-EF			.0078										
VNMG331EEF	VNMG160404N-EF	.375	.1875	.0156	.150									
VNMG332EEF	VNMG160408N-EF			.0313										

Negative Inserts



Swiss Tooling



35° DIAMOND TYPE

NEGATIVE INSERT

Indexable Inserts for Turning

VN

35° Diamond Type

Negative

With Insert Hole

- P** Steel
- M** Stainless Steel
- K** Cast Iron
- N** Non-ferrous
- S** Exotic Materials
- H** Hardened Steel

- USA Stocked Item
- ★ Worldwide Warehouse Item
- ▲ USA Limited Availability Item
- In stock by 1st Quarter 2017

Negative Inserts

C

D

R

S

T

V

W

Swiss Tooling

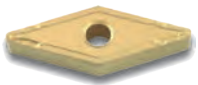
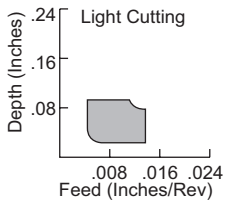
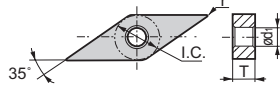
VNMG ESX		Rake Angle: 3°	Cutting Conditions:						Coated		Cermets		Uncoated						
			Continuous Cut	Medium Cut	Interrupted Cut	●	●	●	●	●	●	●	●						
									AC810P	AC8025P	AC820P	AC830P	AC700G	T1500A	T1200A				
									●	●	●	●	●	●	★	▲			
Sumitomo Catalog #	ISO Catalog #	I.C.	T	r	ød1														
VNMG331ESX	VNMG160404N-SX	.375	.1875	.0156	.150														
VNMG332ESX	VNMG160408N-SX			.0313															

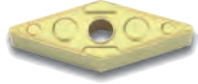
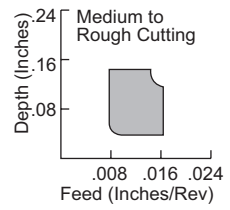
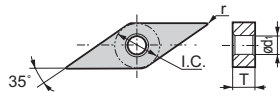
VNMG ENG		Rake Angle: 4°	Cutting Conditions:						Coated		Cermets							
			Continuous Cut	Medium Cut	Interrupted Cut	●	●	●	●	●	●							
									AC8025P	AC820P	AC830P	AC700G		T1200A				
									●	●	●	●		▲				
Sumitomo Catalog #	ISO Catalog #	I.C.	T	r	ød1													
VNMG331ENG	VNMG160404N-UG	.375	.1875	.0156	.150													
VNMG332ENG	VNMG160408N-UG			.0313														

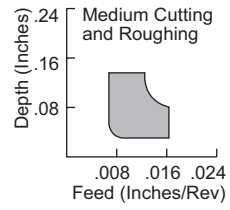
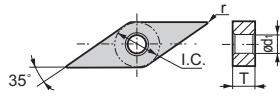
VNMG ENZ/FNZ		Rake Angle: 4°	Cutting Conditions:						Coated		Uncoated							
			Continuous Cut	Medium Cut	Interrupted Cut	●	●	●	●	●	●							
									AC8025P	AC820P	AC830P	AC405K	AC415K	AC420K		G10E		
									●	●	●	●	●	●		●		
Sumitomo Catalog #	ISO Catalog #	I.C.	T	r	ød1													
VNMG331ENZ	VNMG160404N-UZ			.0156														
VNMG332ENZ	VNMG160408N-UZ	.375		.0313	.150													
VNMG333ENZ	VNMG160412N-UZ		.1875	.0469														
VNMG432ENZ	VNMG220408N-UZ			.0313	.2031													
VNMG433ENZ	VNMG220412N-UZ	.500		.0469														
VNMG331FNZ	VNMG160404N-UZ	.375	.1875	.0156	.150													
VNMG332FNZ	VNMG160408N-UZ			.0313														



VN

35° Diamond Type



Negative

With Insert Hole

- P** Steel
- M** Stainless Steel
- K** Cast Iron
- N** Non-ferrous
- S** Exotic Materials
- H** Hardened Steel

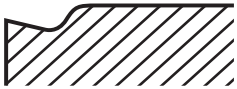
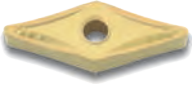
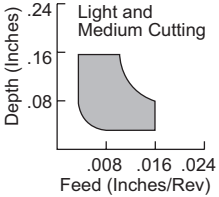
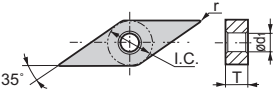
- USA Stocked Item
- ★ Worldwide Warehouse Item
- ▲ USA Limited Availability Item
- In stock by 1st Quarter 2017

VNMG EUP		Rake Angle: 10° 	Cutting Conditions:						Coated					Uncoated						
			Continuous Cut	Medium Cut	Interrupted Cut	●	●	●	●	●	●	●	●	●	●	●	●			
		 <p>Depth (Inches) Feed (Inches/Rev)</p>							AC8025P	AC820P	AC830P	AC510U	AC520U						G10E	
									●	●	●	●	●	●	●	●	●	●	●	●
Sumitomo Catalog #	ISO Catalog #	I.C.	T	r	ød1															
VNMG331EUP	VNMG160404N-UP	.375	.1875	.0156	.150															
VNMG332EUP	VNMG160408N-UP			.0313																

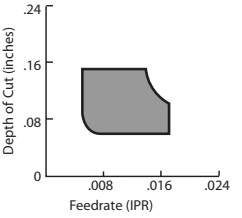
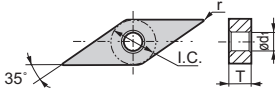
VNMG EEG		Rake Angle: 0° 	Cutting Conditions:						Coated					Cermet					Uncoated					
			Continuous Cut	Medium Cut	Interrupted Cut	●	●	●	●	●	●	●	●	●	●	●	●	●	●					
		 <p>Depth of Cut (inches) Feedrate (IPR)</p>							AC6020M	AC6030M	AC6040M	AC630M	AC510U	AC520U										
									○	○	○	○	○	○	○	○	○	○	○	○	○	○	○	○
Sumitomo Catalog #	ISO Catalog #	I.C.	T	r	ød1																			
VNMG331EEG	VNMG160404N-EG	.375	.1875	.0156	.150																			
VNMG332EEG	VNMG160408N-EG			.0313																				
VNMG333EEG	VNMG160412N-EG			.0469																				

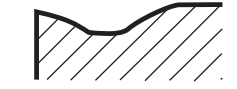
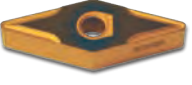
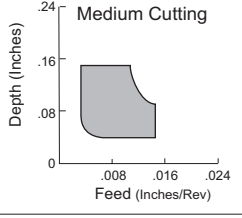
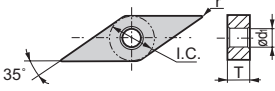
VNMG EEX		Rake Angle: 16° 	Cutting Conditions:						Coated					Uncoated									
			Continuous Cut	Medium Cut	Interrupted Cut	●	●	●	●	●	●	●	●	●	●	●	●						
		 <p>Depth (Inches) Feed (Inches/Rev)</p>							AC610M	AC6020M	AC6030M	AC630M	AC520U										
									●	○	●	●	●	●	○	○	○	○	○	○	○	○	○
Sumitomo Catalog #	ISO Catalog #	I.C.	T	r	ød1																		
VNMG331EEX	VNMG160404N-EX	.375	.1875	.0156	.150																		
VNMG332EEX	VNMG160408N-EX			.0313																			

Negative Inserts

C

D

R

S

T

V

W

Swiss Tooling



35° DIAMOND TYPE

NEGATIVE INSERT

Indexable Inserts for Turning

VN

35° Diamond Type

Negative

With Insert Hole

- P** Steel
- M** Stainless Steel
- K** Cast Iron
- N** Non-ferrous
- S** Exotic Materials
- H** Hardened Steel

- USA Stocked Item
- ★ Worldwide Warehouse Item
- ▲ USA Limited Availability Item
- In stock by 1st Quarter 2017

Negative Inserts

C

D

R



S



T

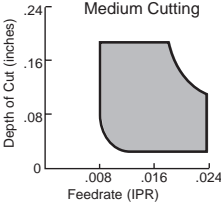
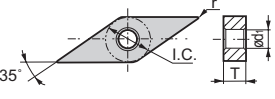

V

W

Swiss Tooling

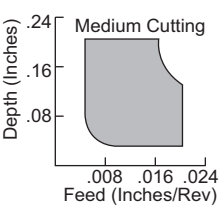
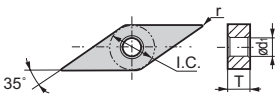
<h3>VNMG EGE</h3> <p>Rake Angle: 3°</p> 		Cutting Conditions:					Coated					Uncoated					
		Continuous Cut	Medium Cut	Interrupted Cut	AC805P	AC810P	AC8025P	AC820P	AC830P								
 <p>Medium Cutting</p>  																	
Sumitomo Catalog #	ISO Catalog #	I.C.	T	r	ød1												
VNMG331EGE	VNMG160404N-GE			.0156		●	●	●	●	●							
VNMG332EGE	VNMG160408N-GE	.375	.1875	.0313	.150	●	●	●	●	●							
VNMG333EGE	VNMG160412N-GE			.0469		●	●	●	●	●							

<h3>VNMG EGU</h3> <p>Rake Angle: 7°</p> 		Cutting Conditions:					Coated					Cermets				
		Continuous Cut	Medium Cut	Interrupted Cut	AC810P	AC8025P	AC820P	AC830P	AC700G	YB100	ACG10M	ACG20M	ACG30M	ACG30M	AC530U	T1500A
 <p>Medium Cutting</p>  																
Sumitomo Catalog #	ISO Catalog #	I.C.	T	r	ød1											
VNMG331EGU	VNMG160404N-GU			.0156		●	●	●	●	●	●	●	●	●	●	●
VNMG332EGU	VNMG160408N-GU	.375	.1875	.0313	.150	●	●	●	●	●	●	●	●	●	●	●
VNMG333EGU	VNMG160412N-GU			.0469		●	●	★	●	●	●	●	●	●	●	●

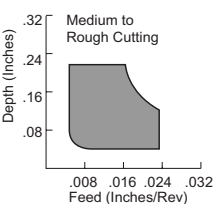
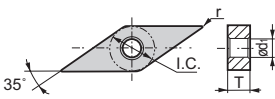
<h3>VNMG EGZ</h3> <p>Rake Angle: 0°</p> 		Cutting Conditions:					Coated					Cermets	Uncoated	
		Continuous Cut	Medium Cut	Interrupted Cut	AC405K	AC415K	AC420K							
 <p>Medium to Rough Cutting</p>  														
Sumitomo Catalog #	ISO Catalog #	I.C.	T	r	ød1									
VNMG331EGZ	VNMG160404N-GZ			.0156		●	●	●						
VNMG332EGZ	VNMG160408N-GZ	.375	.1875	.0313	.150	●	●	●						
VNMG333EGZ	VNMG160412N-GZ			.0469		●	●							



VN

35° Diamond Type

Negative

With Insert Hole

- P Steel
- M Stainless Steel
- K Cast Iron
- N Non-ferrous
- S Exotic Materials
- H Hardened Steel

- USA Stocked Item
- ★ Worldwide Warehouse Item
- ▲ USA Limited Availability Item
- In stock by 1st Quarter 2017

VNMG EUX		Rake Angle: 0° 	Cutting Conditions:						Coated							Cermet						
		<p>Medium Cutting</p>																				
Sumitomo Catalog #	ISO Catalog #	I.C.	T	r	ød1																	
VNMG331EUX	VNMG160404N-UX			.0156																		
VNMG332EUX	VNMG160408N-UX	.375	.1875	.0313	.150	●	●	●	●	●	●	●	●	●	●	●	●	●	●	●	●	●
VNMG333EUX	VNMG160412N-UX			.0469		●	●	●	●	●	●	●	●	●	●	●	●	●	●	●	●	●

VNMA		No Breaker 	Cutting Conditions:						Coated							Uncoated						
		—																				
Sumitomo Catalog #	ISO Catalog #	I.C.	T	r	ød1																	
VNMA331	VNMA160404			.0156		★	●	●	●	●	●	●	●	●	●	●	●	●	●	●	●	●
VNMA332	VNMA160408	.375	.1875	.0313	.150	●	●	●	●	●	●	●	●	●	●	●	●	●	●	●	●	●
VNMA333	VNMA160412			.0469		●	●	●	●	●	●	●	●	●	●	●	●	●	●	●	●	●

Negative Inserts



Swiss Tooling



TRIGON TYPE

NEGATIVE INSERT

Indexable Inserts for Turning

WN

Trigon Type

Negative

With Insert Hole

- P** Steel
- M** Stainless Steel
- K** Cast Iron
- N** Non-ferrous
- S** Exotic Materials
- H** Hardened Steel

- USA Stocked Item
- ★ Worldwide Warehouse Item
- ▲ USA Limited Availability Item
- In stock by 1st Quarter 2017

Negative Inserts

C

D

R

S

T



V

W

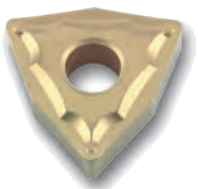
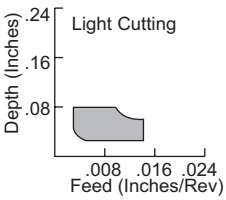
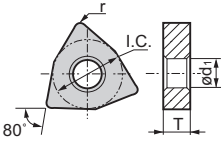
Swiss Tooling

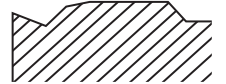
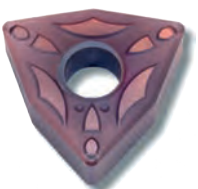
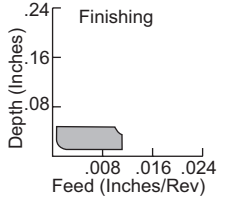
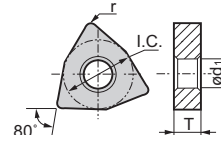
WNGG ESU		Rake Angle: 13° 	Cutting Conditions:				Coated		Cermet		Uncoated			
			Continuous Cut	Medium Cut	Interrupted Cut	●	●	●	●	●	●	●	●	
							AC520U		T1500Z		H1			
Sumitomo Catalog #	ISO Catalog #	I.C.	T	r	ød1									
WNGG431ESU	WNGG080404N-SU	.500	.1875	.0156	.2031	●		★						
WNGG431ESUJ	WNGG080404N-SUJ							●						

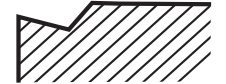
WNMG EFA		Rake Angle: 20° 	Cutting Conditions:				Coated		Cermet		Uncoated			
			Continuous Cut	Medium Cut	Interrupted Cut	●	●	●	●	●	●	●		
									T1500Z					
Sumitomo Catalog #	ISO Catalog #	I.C.	T	r	ød1									
WNMG430.5EFA	WNMG080402N-FA	.500	.1875	.0078	.2031			●						
WNMG431EFA	WNMG080404N-FA			.0156				●						
WNMG432EFA	WNMG080408N-FA			.0313				●						

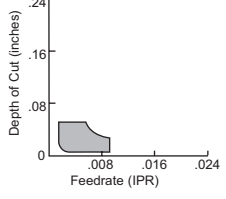
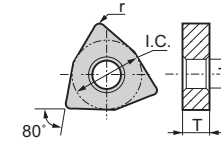
WNMG EFL		Rake Angle: 10° 	Cutting Conditions:				Coated		Cermet		Uncoated			
			Continuous Cut	Medium Cut	Interrupted Cut	●	●	●	●	●	●			
							AC810P		T1500Z					
Sumitomo Catalog #	ISO Catalog #	I.C.	T	r	ød1									
WNMG431EFL	WNMG080404N-FL	.500	.1875	.0156	.2031	●		●						
WNMG432EFL	WNMG080408N-FL			.0313		●		●						



WN Trigon Type
Negative
With Insert Hole

- P** Steel
- M** Stainless Steel
- K** Cast Iron
- N** Non-ferrous
- S** Exotic Materials
- H** Hardened Steel

- USA Stocked Item
- ★ Worldwide Warehouse Item
- ▲ USA Limited Availability Item
- In stock by 1st Quarter 2017

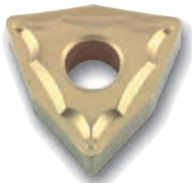
WNMG ESU		Rake Angle: 13°	Cutting Conditions:				Coated										Cermet								
							Continuous Cut										Medium Cut				Interrupted Cut				
							AC810P	AC8025P	AC820P	AC830P	AC700G	YB100	AC6030M	AC6040M	AC630M	AC530U	AC510U	AC520U	T1500Z	T2000Z	T3000Z	T1500A	T1200A		
							●	●	●	●	●	●	●	●	●	●	●	●	●	●	●	●	●	●	●
Sumitomo Catalog #	ISO Catalog #	I.C.	T	r	ød1																				
WNMG331ESU	WNMG060404N-SU	.375		.0156	.150																				
WNMG332ESU	WNMG060408N-SU			.0313																					
WNMG431ESU	WNMG080404N-SU		.1875	.0156																					
WNMG432ESU	WNMG080408N-SU	.500		.0313	.2031																				
WNMG433ESU	WNMG080412N-SU			.0469																					

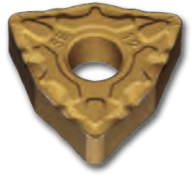
WNMG ESE		Rake Angle: 13°	Cutting Conditions:				Coated										Cermet										
							Continuous Cut										Medium Cut				Interrupted Cut						
							AC810P	AC8025P	AC820P	AC830P											T1500A						
							●	●	●	●											●						
Sumitomo Catalog #	ISO Catalog #	I.C.	T	r	ød1																						
WNMG431ESE	WNMG080404N-SE			.0156																							
WNMG432ESE	WNMG080408N-SE	.500	.1875	.0313	.2031																						
WNMG433ESE	WNMG080412N-SE			.0469																							

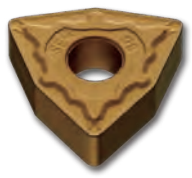
WNMG ESEW Wiper Insert		Rake Angle: 13°	Cutting Conditions:				Coated										Cermet											
							Continuous Cut										Medium Cut				Interrupted Cut							
							AC805P	AC810P	AC8025P	AC820P	AC830P											T1500A						
							●	●	●	●	●											●						
Sumitomo Catalog #	ISO Catalog #	I.C.	T	r	ød1																							
WNMG331ESEW	WNMG060404N-SEW	.375		.0156	.150																							
WNMG332ESEW	WNMG060408N-SEW			.0313																								
WNMG431ESEW	WNMG080404N-SEW		.1875	.0156																								
WNMG432ESEW	WNMG080408N-SEW	.500		.0313	.2031																							
WNMG433ESEW	WNMG080412N-SEW			.0469																								



TRIGON TYPE

NEGATIVE INSERT

Indexable Inserts for Turning

WN

Trigon Type

Negative

With Insert Hole

- P** Steel
- M** Stainless Steel
- K** Cast Iron
- N** Non-ferrous
- S** Exotic Materials
- H** Hardened Steel

- USA Stocked Item
- ★ Worldwide Warehouse Item
- ▲ USA Limited Availability Item
- In stock by 1st Quarter 2017

Negative Inserts

C

D

R

S

T

V

W

Swiss Tooling

WNMG ELU		Rake Angle: 10°	Cutting Conditions:				Coated			Cermet			Uncoated													
							Continuous Cut	Medium Cut	Interrupted Cut	AC810P	AC8025P	AC820P	AC830P	AC700G	T1500Z	T2000Z	T3000Z	T1500A	T1200A							
Sumitomo Catalog #	ISO Catalog #	I.C.	T	r	ød1	AC810P	AC8025P	AC820P	AC830P	AC700G	T1500Z	T2000Z	T3000Z	T1500A	T1200A											
WNMG331ELU	WNMG060404N-LU	.375		.0156	.150	●	●	●	●	●	●	●	●	●	●											
WNMG332ELU	WNMG060408N-LU			.0313		●	●	●	●	●	●	●	●	●	●											
WNMG431ELU	WNMG080404N-LU		.1875	.0156		●	●	●	●	●	●	●	●	●	●											
WNMG432ELU	WNMG080408N-LU	.500		.0313	.2031	●	●	●	●	●	●	●	●	●	●											
WNMG433ELU	WNMG080412N-LU			.0469		●	●	●	●	●	●	●	●	●	●											

WNMG ELUW Wiper Insert		Rake Angle: 10°	Cutting Conditions:				Coated			Cermet			Uncoated													
							Continuous Cut	Medium Cut	Interrupted Cut	AC810P	AC8025P	AC820P	AC700G	YB100	AC6030M	AC630M	T1500Z	T2000Z	T3000Z	T1500A						
Sumitomo Catalog #	ISO Catalog #	I.C.	T	r	ød1	AC810P	AC8025P	AC820P	AC700G	YB100	AC6030M	AC630M	T1500Z	T2000Z	T3000Z	T1500A										
WNMG331ELUW	WNMG060404N-LUW	.375		.0156	.150	●	●	●	●	●	●	●	●	●	●											
WNMG332ELUW	WNMG060408N-LUW			.0313		●	●	●	●	●	●	●	●	●	●											
WNMG431ELUW	WNMG080404N-LUW		.1875	.0156		●	●	●	●	●	●	●	●	●	●											
WNMG432ELUW	WNMG080408N-LUW	.500		.0313	.2031	●	●	●	●	●	●	●	●	●	●											
WNMG433ELUW	WNMG080412N-LUW			.0469		●	●	●	●	●	●	●	●	●	●											

WNMG ENK		Rake Angle: 10°	Cutting Conditions:				Coated			Cermet			Uncoated													
							Continuous Cut	Medium Cut	Interrupted Cut	AC820P																
Sumitomo Catalog #	ISO Catalog #	I.C.	T	r	ød1	AC820P																				
WNMG431ENK	WNMG080404N-SK	.500	.1875	.0156	.2031	●																				
WNMG432ENK	WNMG080408N-SK			.0313		●																				



WN

Trigon Type

Negative

With Insert Hole

- P** Steel
- M** Stainless Steel
- K** Cast Iron
- N** Non-ferrous
- S** Exotic Materials
- H** Hardened Steel

- USA Stocked Item
- ★ Worldwide Warehouse Item
- ▲ USA Limited Availability Item
- In stock by 1st Quarter 2017

WNMG EEF		Rake Angle: 20° 	Cutting Conditions:						Coated		Cermet		Uncoated	
			Continuous Cut	Medium Cut	Interrupted Cut	●	●	●	●	●	●	●	●	
Sumitomo Catalog #	ISO Catalog #	I.C.	T	r	ød1	AC6020M	AC6030M	AC6040M	AC630M	AC510U	AC520U	EH510	EH520	
WNMG331EEF	WNMG060404N-EF	.375	.1875	.0156	.150	●	●	●	●	●	●	●	●	
WNMG332EEF	WNMG060408N-EF			.0313		●	●	●	●	●	●	●	●	
WNMG431EEF	WNMG080404N-EF	.500		.0156	.2031	●	●	●	●	●	●	●	●	
WNMG432EEF	WNMG080408N-EF			.0313		●	●	●	●	●	●	●	●	

WNMG ESX		Rake Angle: 3° 	Cutting Conditions:						Coated		Cermet		Uncoated		
			Continuous Cut	Medium Cut	Interrupted Cut	●	●	●	●	●	●	●	●		
Sumitomo Catalog #	ISO Catalog #	I.C.	T	r	ød1	AC810P	AC8025P	AC820P	AC830P	AC700G	T1500Z	T2000Z	T3000Z	T1500A	T1200A
WNMG431ESX	WNMG080404N-SX	.500	.1875	.0156	.2031	●	●	●	●	●	●	●	●	●	●
WNMG432ESX	WNMG080408N-SX			.0313		●	●	●	●	●	●	●	●	●	●
WNMG433ESX	WNMG080412N-SX			.0469		●	●	●	●	●	●	●	●	●	●

WNMG EUP		Rake Angle: 10° 	Cutting Conditions:						Coated		Uncoated				
			Continuous Cut	Medium Cut	Interrupted Cut	●	●	●	●	●	●	●			
Sumitomo Catalog #	ISO Catalog #	I.C.	T	r	ød1	AC8025P	AC820P	AC830P	AC6030M	AC6040M	AC630M	AC530U	AC510U	AC520U	G10E
WNMG432EUP	WNMG080408N-UP	.500	.1875	.0313	.2031	●	●	●	●	●	●	●	●	●	●
WNMG433EUP	WNMG080412N-UP			.0469		●	●	●	●	●	●	●	●	●	●



Negative Inserts



Swiss Tooling

TRIGON TYPE

NEGATIVE INSERT

Indexable Inserts for Turning

WN

Trigon Type

Negative

With Insert Hole

- P** Steel
- M** Stainless Steel
- K** Cast Iron
- N** Non-ferrous
- S** Exotic Materials
- H** Hardened Steel

- USA Stocked Item
- ★ Worldwide Warehouse Item
- ▲ USA Limited Availability Item
- In stock by 1st Quarter 2017

Negative Inserts

C

D

R

S

T

V

W

Swiss Tooling

WNMG

Rake Angle: 0°

EEG

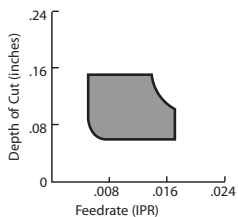

Cutting Conditions:

Continuous Cut

Medium Cut

Interrupted Cut

Coated Cermet Uncoated

Material	AC8025P	AC6020M	AC6030M	AC6040M	AC630M	AC510U	AC520U	EH510	EH520
Continuous Cut	●	●	●	●	●	●	●	●	●
Medium Cut	●	●	●	●	●	●	●	●	●
Interrupted Cut	●	●	●	●	●	●	●	●	●

Sumitomo Catalog #	ISO Catalog #	I.C.	T	r	ød1
WNMG332EEG	WNMG060408N-EG	.375		.0313	.150
WNMG333EEG	WNMG060412N-EG			.0469	
WNMG431EEG	WNMG080404N-EG		.1875	.0156	
WNMG432EEG	WNMG080408N-EG	.500		.0313	.2031
WNMG433EEG	WNMG080412N-EG			.0469	

WNMG

Rake Angle: 16°

EEX

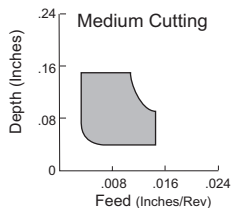

Cutting Conditions:

Continuous Cut

Medium Cut

Interrupted Cut

Coated Uncoated

Material	AC530U	AC610M	AC6020M	AC6030M	AC6040M	AC630M	AC510U	AC520U	EH510	EH520
Continuous Cut	●	●	●	●	●	●	●	●	●	●
Medium Cut	●	●	●	●	●	●	●	●	●	●
Interrupted Cut	●	●	●	●	●	●	●	●	●	●

Sumitomo Catalog #	ISO Catalog #	I.C.	T	r	ød1
WNMG331EEX	WNMG060404N-EX	.375		.0156	.150
WNMG332EEX	WNMG060408N-EX			.0313	
WNMG431EEX	WNMG080404N-EX		.1875	.0156	
WNMG432EEX	WNMG080408N-EX	.500		.0313	.2031
WNMG433EEX	WNMG080412N-EX			.0469	

WNMG

Rake Angle: 7°

EGU

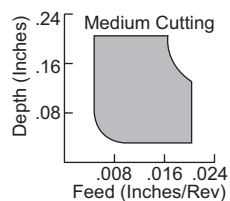
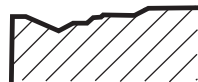

Cutting Conditions:

Continuous Cut

Medium Cut

Interrupted Cut

Coated Cermet

Material	AC810P	AC8025P	AC820P	AC830P	AC700G	YB100	AC530U	AC610M	AC6020M	AC6030M	AC630M	T1500A	T1200A
Continuous Cut	●	●	●	●	●	●	●	●	●	●	●	●	●
Medium Cut	●	●	●	●	●	●	●	●	●	●	●	●	●
Interrupted Cut	●	●	●	●	●	●	●	●	●	●	●	●	●

Sumitomo Catalog #	ISO Catalog #	I.C.	T	r	ød1
WNMG331EGU	WNMG060404N-GU	.375		.0156	.150
WNMG332EGU	WNMG060408N-GU			.0313	
WNMG333EGU	WNMG060412N-GU			.0469	
WNMG431EGU	WNMG080404N-GU		.1875	.0156	
WNMG432EGU	WNMG080408N-GU	.500		.0313	.2031
WNMG433EGU	WNMG080412N-GU			.0469	



WN

Trigon Type

Negative

With Insert Hole

- P** Steel
- M** Stainless Steel
- K** Cast Iron
- N** Non-ferrous
- S** Exotic Materials
- H** Hardened Steel

- USA Stocked Item
- ★ Worldwide Warehouse Item
- ▲ USA Limited Availability Item
- In stock by 1st Quarter 2017

<h3>WNMG EGUW</h3> Wiper Insert		Rake Angle: 0° 	Cutting Conditions:						Coated				Cermet		Uncoated		
			Continuous Cut	Medium Cut	Interrupted Cut	●	●	●	●	●	●	●	●	●	●	●	●
					AC810P	AC8025P	AC820P	AC830P	AC700G	AC6030M	AC630M	AC405K	AC415K				
Sumitomo Catalog #	ISO Catalog #	I.C.	T	r	ød1												
WNMG332EGUW	WNMG060408N-GUW	.375		.0313	.150	●	●	●	●	●	●	●	●				
WNMG432EGUW	WNMG080408N-GUW	.500	.1875	.0313	.2031	●	●	●	●	●	●	●	●				
WNMG433EGUW	WNMG080412N-GUW			.0469		●	●	●	●	●	●	●	●				

<h3>WNMG EGE</h3>		Rake Angle: 3° 	Cutting Conditions:						Coated				Uncoated				
			Continuous Cut	Medium Cut	Interrupted Cut	●	●	●	●	●	●	●	●	●	●		
					AC805P	AC810P	AC8025P	AC820P	AC830P	AC700G							
Sumitomo Catalog #	ISO Catalog #	I.C.	T	r	ød1												
WNMG332EGE	WNMG060408N-GE	.375		.0313	.150	●	●	●	●	●							
WNMG333EGE	WNMG060412N-GE			.0469		●	●	●	●	●							
WNMG432EGE	WNMG080408N-GE	.500	.1875	.0313	.2031	●	●	●	●	●							
WNMG433EGE	WNMG080412N-GE			.0469		●	●	●	●	●							
WNMG434EGE	WNMG080416N-GE			.0625		●	●	●	●	●							

<h3>WNMG EUX</h3>		Rake Angle: 0° 	Cutting Conditions:						Coated				Cermet				
			Continuous Cut	Medium Cut	Interrupted Cut	●	●	●	●	●	●	●	●	●	●		
					AC810P	AC8025P	AC820P	AC830P	AC700G	YB100	AC410K						
Sumitomo Catalog #	ISO Catalog #	I.C.	T	r	ød1												
WNMG431EUX	WNMG080404N-UX	.500	.1875	.0156	.2031	●	●	●	●	●	▲						
WNMG432EUX	WNMG080408N-UX			.0313		●	●	●	●	●	●						
WNMG433EUX	WNMG080412N-UX			.0469		●	●	●	●	●	▲						



Negative Inserts



Swiss Tooling

TRIGON TYPE

NEGATIVE INSERT

Indexable Inserts for Turning

WN

Trigon Type

Negative

With Insert Hole

- P** Steel
- M** Stainless Steel
- K** Cast Iron
- N** Non-ferrous
- S** Exotic Materials
- H** Hardened Steel

- USA Stocked Item
- ★ Worldwide Warehouse Item
- ▲ USA Limited Availability Item
- In stock by 1st Quarter 2017

Negative Inserts

C

D

R

S

T

V

W

Swiss Tooling

WNMG ENG		Rake Angle: 4° 	Cutting Conditions:				Coated				Cermet			
			Continuous Cut	Medium Cut	Interrupted Cut	AC8025P	AC820P	AC830P	AC700G					
		Depth (Inches) Medium Cutting Feed (Inches/Rev)												
Sumitomo Catalog #	ISO Catalog #	I.C.	T	r	ød1									
WNMG431ENG	WNMG080404N-UG			.0156		●	●	●	●					
WNMG432ENG	WNMG080408N-UG	.500	.1875	.0313	.2031	●	●	●	●					
WNMG433ENG	WNMG080412N-UG			.0469		●	●	●	●					
WNMG543ENG	WNMG160612N-UG	.625	.250	.0469	.250	●	●	●	●					

WNMG ENZ		Rake Angle: 4° 	Cutting Conditions:				Coated				Uncoated			
			Continuous Cut	Medium Cut	Interrupted Cut	AC8025P	AC820P	AC830P	AC700G	AC405K	AC410K	AC415K	AC420K	G10E
		Depth (Inches) Medium Cutting and Roughing Feed (Inches/Rev)												
Sumitomo Catalog #	ISO Catalog #	I.C.	T	r	ød1									
WNMG431ENZ	WNMG080404N-UZ			.0156		●	●	●	●	●	●	●		
WNMG432ENZ	WNMG080408N-UZ	.500	.1875	.0313	.2031	●	●	●	●	●	●	●	▲	
WNMG433ENZ	WNMG080412N-UZ			.0469		●	●	●	●	●	●	●		





WNMG EEM		Rake Angle: 0° 	Cutting Conditions:				Coated				Uncoated			
			Continuous Cut	Medium Cut	Interrupted Cut	AC8025P	AC6030M	AC6040M	AC510U	AC520U				
		Depth (Inches) Roughing Feed (Inches/Rev)												
Sumitomo Catalog #	ISO Catalog #	I.C.	T	r	ød1									
WNMG432EEM	WNMG080408N-EM	.500	.1875	.0313	.2031	●	●	●	●	●				
WNMG433EEM	WNMG080412N-EM			.0469		●	●	●	●	●				





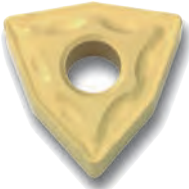
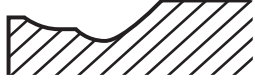

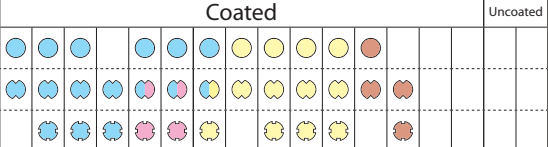
WN Trigon Type
Negative
With Insert Hole

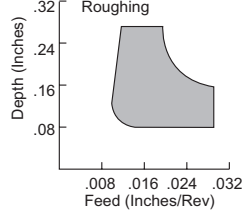
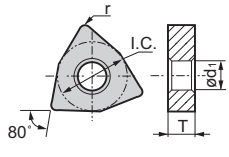
- P** Steel
- M** Stainless Steel
- K** Cast Iron
- N** Non-ferrous
- S** Exotic Materials
- H** Hardened Steel

- USA Stocked Item
- ★ Worldwide Warehouse Item
- ▲ USA Limited Availability Item
- In stock by 1st Quarter 2017

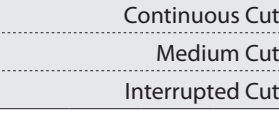
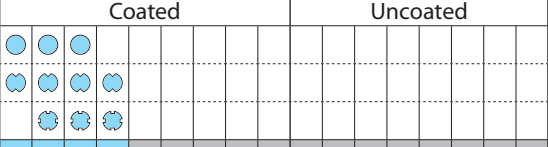
WNMG EMU		Rake Angle: 4°	Cutting Conditions:						Coated										Uncoated	
			Continuous Cut	Medium Cut	Interrupted Cut	AC810P	AC8025P	AC820P	AC830P	AC700G	YB100	AC530U	AC610M	AC6030M	AC6040M	AC630M	AC510U	AC520U		
																				
																				
Sumitomo Catalog #	ISO Catalog #	I.C.	T	r	ød1	AC810P	AC8025P	AC820P	AC830P	AC700G	YB100	AC530U	AC610M	AC6030M	AC6040M	AC630M	AC510U	AC520U		
WNMG332EMU	WNMG060408N-MU	.375		.0313	.150	●	●	●	●	●	●	●	●	●	●	●	●	●		
WNMG333EMU	WNMG060412N-MU		.1875	.0469		●	●	●	●	●	●	●	●	●	●	●	●	●		
WNMG432EMU	WNMG080408N-MU	.500		.0313	.2031	●	●	●	●	●	●	●	●	●	●	●	●	●		
WNMG433EMU	WNMG080412N-MU		.1875	.0469		●	●	●	●	●	●	●	●	●	●	●	●	●		
WNMG543EMU	WNMG160612N-MU	.625	.250	.0469	.250	●	●	●	●	●	●	●	●	●	●	●	●	●		

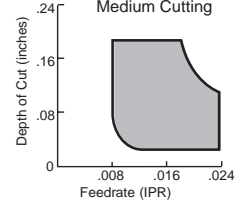
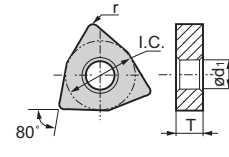
WNMG EME		Rake Angle: 3°	Cutting Conditions:						Coated										Uncoated	
			Continuous Cut	Medium Cut	Interrupted Cut	AC810P	AC8025P	AC820P	AC830P											
																				
																				
Sumitomo Catalog #	ISO Catalog #	I.C.	T	r	ød1	AC810P	AC8025P	AC820P	AC830P											
WNMG332EME	WNMG060408N-ME	.375		.0313	.150	●	●	●	●											
WNMG333EME	WNMG060412N-ME		.1875	.0469		●	●	●	●											
WNMG432EME	WNMG080408N-ME	.500		.0313	.2031	●	●	●	●											
WNMG433EME	WNMG080412N-ME		.1875	.0469		●	●	●	●											
WNMG434EME	WNMG080416N-ME		.250	.0625		●	●	●	●											

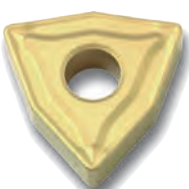
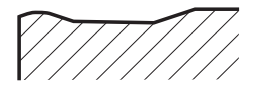
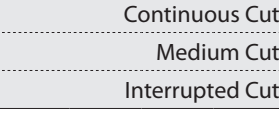
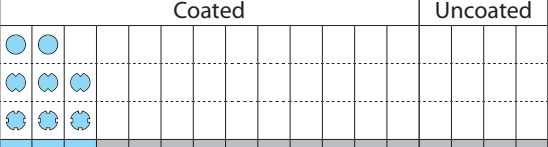
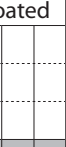
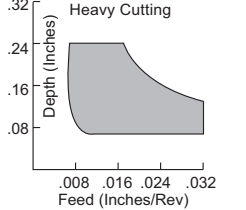
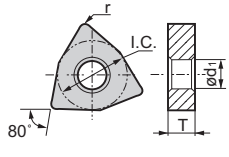
WNMG EMX		Rake Angle: -15°	Cutting Conditions:						Coated										Uncoated	
			Continuous Cut	Medium Cut	Interrupted Cut	AC8025P	AC820P	AC830P												
																				
																				
Sumitomo Catalog #	ISO Catalog #	I.C.	T	r	ød1	AC8025P	AC820P	AC830P												
WNMG432EMX	WNMG080408N-MX	.500	.1875	.0313	.2031	●	●	●												
WNMG433EMX	WNMG080412N-MX		.1875	.0469		●	●	●												



TRIGON TYPE

NEGATIVE INSERT

Indexable Inserts for Turning

WN

Trigon Type

Negative

With Insert Hole

- P** Steel
- M** Stainless Steel
- K** Cast Iron
- N** Non-ferrous
- S** Exotic Materials
- H** Hardened Steel

- USA Stocked Item
- ★ Worldwide Warehouse Item
- ▲ USA Limited Availability Item
- In stock by 1st Quarter 2017

Negative Inserts

C

D

R

S

T

V

W

Swiss Tooling

<h2>WNMG</h2> <h2>EGZ</h2>		Rake Angle: 0° 	Cutting Conditions:					Coated					Uncoated						
			Continuous Cut	Medium Cut	Interrupted Cut														
								AC405K	AC410K	AC415K	AC420K								
Sumitomo Catalog #	ISO Catalog #	I.C.	T	r	ød1	AC405K	AC410K	AC415K	AC420K										
WNMG332EGZ	WNMG060408N-GZ	.375		.0313	.150	●	●	●	●										
WNMG333EGZ	WNMG060412N-GZ			.0469		●	●	●	●										
WNMG431EGZ	WNMG080404N-GZ		.1875	.0156		●	●	●	●										
WNMG432EGZ	WNMG080408N-GZ	.500		.0313	.2031	●	●	●	●										
WNMG433EGZ	WNMG080412N-GZ			.0469		●	▲	●	●										

<h2>WNMA</h2>		No Breaker 	Cutting Conditions:					Coated					Uncoated						
			Continuous Cut	Medium Cut	Interrupted Cut														
								AC700G	AC405K	AC410K	AC415K	AC420K							
Sumitomo Catalog #	ISO Catalog #	I.C.	T	r	ød1	AC700G	AC405K	AC410K	AC415K	AC420K									
WNMA432	WNMA080408			.0313		●	●	▲	●	●									
WNMA433	WNMA080412	.500	.1875	.0469	.2031	●	●	▲	●	●									
WNMA434	WNMA080416			.0625		●	●	●	●	●									



CC

80° Diamond Type

7° Relief

With Insert Hole

- P** Steel
- M** Stainless Steel
- K** Cast Iron
- N** Non-ferrous
- S** Exotic Materials
- H** Hardened Steel

- USA Stocked Item
- ★ Worldwide Warehouse Item
- ▲ USA Limited Availability Item
- In stock by 1st Quarter 2017

CCET		Rake Angle: 15°		Cutting Conditions:			Coated	Cermet	Uncoated
FY				Continuous Cut	○				
				Medium Cut	○				
				Interrupted Cut	○				
Sumitomo Catalog #	ISO Catalog #	I.C.	T	r	ød1	AC530U			
CCET03X1003LFY	CCET03X1003LFY			.0012		★			
CCET03X1011LFY	CCET03X1011LFY	.1378	.055	.0039	.071	★			
CCET03X102LFY	CCET03X102LFY			.0078		★			
CCET03X104LFY	CCET03X104LFY			.0156		★			
CCET04X1003LFY	CCET04X1003LFY			.0012		★			
CCET04X1011LFY	CCET04X1011LFY	.1693	.071	.0039	.087	★			
CCET04X102LFY	CCET04X102LFY			.0078		★			
CCET04X104LFY	CCET04X104LFY			.0156		★			

CCGT		Rake Angle: 15°		Cutting Conditions:			Coated	Cermet	Uncoated
FX				Continuous Cut	○		●		
				Medium Cut	○		●		
				Interrupted Cut	○		●		
Sumitomo Catalog #	ISO Catalog #	I.C.	T	r	ød1	AC530U	ACZ310		
CCGT21.5.001RFX	CCGT0602003R-FX			.0012		★	▲		
CCGT21.5.001LFX	CCGT0602003L-FX			.0012		★	▲		
CCGT21.50RFX	CCGT060201R-FX			.0039		★	▲		
CCGT21.50LFX	CCGT060201L-FX			.0039		●	▲		
CCGT21.50.5RFX	CCGT060202R-FX	.250	.094	.0078	.110	★	▲		
CCGT21.50.5LFX	CCGT060202L-FX			.0078		●	▲		
CCGT21.51RFX	CCGT060204R-FX			.0156		●	▲		
CCGT21.51LFX	CCGT060204L-FX			.0156		●	▲		
CCGT32.5.001RFX	CCGT09T3003R-FX			.0012		★	▲		
CCGT32.5.001LFX	CCGT09T3003L-FX			.0012		★	▲		
CCGT32.50RFX	CCGT09T301R-FX			.0039		★	▲		
CCGT32.50LFX	CCGT09T301L-FX			.0039		★	▲		
CCGT32.50.5RFX	CCGT09T302R-FX	.375	.156	.0078	.1732	★	▲		
CCGT32.50.5LFX	CCGT09T302L-FX			.0078		★	▲		
CCGT32.51RFX	CCGT09T304R-FX			.0156		●	▲		
CCGT32.51LFX	CCGT09T304L-FX			.0156		★	▲		

Positive Inserts

C

D

R

S

T

V

W

Swiss Tooling



80° DIAMOND TYPE

POSITIVE INSERT

Indexable Inserts for Turning

CC

80° Diamond Type

7° Relief

With Insert Hole

- P** Steel
- M** Stainless Steel
- K** Cast Iron
- N** Non-ferrous
- S** Exotic Materials
- H** Hardened Steel

- USA Stocked Item
- ★ Worldwide Warehouse Item
- ▲ USA Limited Availability Item
- In stock by 1st Quarter 2017

CCGT EFM		Rake Angle: 6°		Cutting Conditions:		Coated	Cermet				Uncoated			
				Continuous Cut		● ○								
				Medium Cut		● ○								
				Interrupted Cut		● ○								
						AC530U								
							T1500Z	T2000Z	T1500A	T1200A				
Sumitomo Catalog #	ISO Catalog #	I.C.	T	r	ød1									
CCGT21.5.001EFM	CCGT0602003N-SC			.0012		● ▲								
CCGT21.50EFM	CCGT060201N-SC			.0039		★ ▲								
CCGT21.50MEFM	CCGT060201MN-SC	.250		.0039	.110									
CCGT21.50.5EFM	CCGT060202N-SC		.094	.0078		● ▲								
CCGT21.50.5MEFM	CCGT060202MN-SC			.0078										
CCGT2.51.50EFM	CCGT080201N-SC			.0039		● ▲								
CCGT2.51.50.5EFM	CCGT080202N-SC	.3125		.0078	.134									
CCGT32.5.001EFM	CCGT09T3003N-SC			.0012		● ▲								
CCGT32.50EFM	CCGT09T301N-SC			.0039		● ▲								
CCGT32.50MEFM	CCGT09T301MN-SC	.375	.156	.0039	.1732									
CCGT32.50.5EFM	CCGT09T302N-SC			.0078		● ▲								
CCGT32.50.5MEFM	CCGT09T302MN-SC			.0078										

M = Negative nose radius tolerance (-0.0001" to -0.0004")

CCGT NAG		Rake Angle: 20°		Cutting Conditions:		Coated	Cermet				Uncoated					
				Continuous Cut								●				
				Medium Cut										●		
				Interrupted Cut												
												H1				
Sumitomo Catalog #	ISO Catalog #	I.C.	T	r	ød1											
CCGT21.51NAG	CCGT060204N-AG	.250	.094	.0156	.110											
CCGT32.51NAG	CCGT09T304N-AG			.0156												
CCGT32.52NAG	CCGT09T308N-AG	.375	.156	.0313	.1732											



CC

80° Diamond Type

7° Relief

With Insert Hole

- P** Steel
- M** Stainless Steel
- K** Cast Iron
- N** Non-ferrous
- S** Exotic Materials
- H** Hardened Steel

- USA Stocked Item
- ★ Worldwide Warehouse Item
- ▲ USA Limited Availability Item
- In stock by 1st Quarter 2017

CCGT EFC		Rake Angle: 15° 	Cutting Conditions:						Coated		Cermet		Uncoated	
			Continuous Cut	Medium Cut	Interrupted Cut	●	●	●	●	●	●	●		
									AC530U		T1500A			
Sumitomo Catalog #	ISO Catalog #	I.C.	T	r	ød1									
CCGT21.50EFC	CCGT060201N-FC			.0039		●								
CCGT21.50MEFC	CCGT060201MN-FC			.0039		●								
CCGT21.50.5EFC	CCGT060202N-FC	.250	.094	.0078	.110	●								
CCGT21.50.5MEFC	CCGT060202MN-FC			.0078		●								
CCGT21.51EFC	CCGT060204N-FC			.0156		●								
CCGT21.51MEFC	CCGT060204MN-FC			.0156		●								
CCGT32.5.001EFC	CCGT09T3003N-FC			.0012		●								
CCGT32.50EFC	CCGT09T301N-FC			.0039		●								
CCGT32.50MEFC	CCGT09T301MN-FC			.0039		●								
CCGT32.50.5EFC	CCGT09T302N-FC	.375	.156	.0078	.1732	●								
CCGT32.50.5MEFC	CCGT09T302MN-FC			.0078		●								
CCGT32.51EFC	CCGT09T304N-FC			.0156		●								
CCGT32.51MEFC	CCGT09T304MN-FC			.0156		●								

M = Negative nose radius tolerance (-0.0001" to -0.0004")

CCGT ESI		Rake Angle: 15° 	Cutting Conditions:						Coated		Cermet		Uncoated			
			Continuous Cut	Medium Cut	Interrupted Cut	●	●	●	●	●	●	●				
									AC530U	AC610M	AC6030M	AC630M	AC510U	AC520U	T1500Z	V00A
Sumitomo Catalog #	ISO Catalog #	I.C.	T	r	ød1											
CCGT32.50MESI	CCGT09T301MN-SI			.0039		●										
CCGT32.50.5MESI	CCGT09T302MN-SI	.375	.156	.0078	.1732	●										
CCGT32.51MESI	CCGT09T304MN-SI			.0156		●										

M = Negative nose radius tolerance (-0.0001" to -0.0004")

Positive Inserts
C
D
R
S
T
V
W
Swiss Tooling



80° DIAMOND TYPE

POSITIVE INSERT



Indexable Inserts for Turning

CC 80° Diamond Type
7° Relief
With Insert Hole

- P** Steel
- M** Stainless Steel
- K** Cast Iron
- N** Non-ferrous
- S** Exotic Materials
- H** Hardened Steel

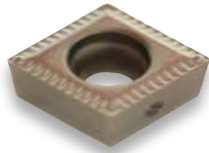
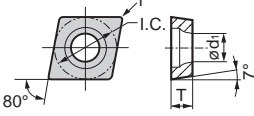
- USA Stocked Item
- ★ Worldwide Warehouse Item
- ▲ USA Limited Availability Item
- In stock by 1st Quarter 2017

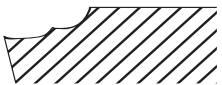
CCMT EFB		Rake Angle: 20° 	Cutting Conditions:				Coated		Cermet		Uncoated			
			Continuous Cut	Medium Cut	Interrupted Cut									
		Finishing Depth (Inches) vs. Feed (Inches/Rev) graph Feed: .008, .016, .024					T1500Z		T1500A					
CCMT21.50.5EFB	CCMT060202N-FB	.250	.094	.0078	.110	●	●	●	●					
CCMT21.51EFB	CCMT060204N-FB			.0156		●	●	●	●					
CCMT32.51EFB	CCMT09T304N-FB	.375	.156	.0156	.1732	●	●	●	●					
CCMT32.52EFB	CCMT09T308N-FB			.0313		●	●	●	●					

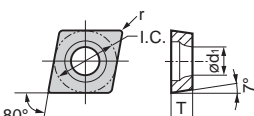
CCMT EFP		Rake Angle: 10° 	Cutting Conditions:				Coated		Cermet		Uncoated			
			Continuous Cut	Medium Cut	Interrupted Cut									
		Light Cutting Depth (Inches) vs. Feed (Inches/Rev) graph Feed: .008, .016, .024					T2000Z		T1500A		T1200A			
CCMT21.51EFP	CCMT060204N-FP	.250	.094	.0156	.110	●	●	●	●					
CCMT32.51EFP	CCMT09T304N-FP	.375	.156	.0156	.1732	●	●	●	●					
CCMT32.52EFP	CCMT09T308N-FP			.0313		●	●	●	●					

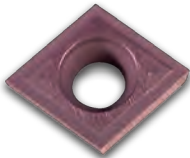
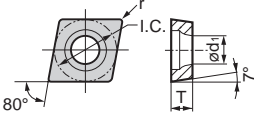
CCMT EFM		Rake Angle: 6° 	Cutting Conditions:				Coated		Cermet		Uncoated			
			Continuous Cut	Medium Cut	Interrupted Cut									
		Light Cutting Depth (Inches) vs. Feed (Inches/Rev) graph Feed: .008, .016, .024					AC8025P		AC820P					
CCMT21.51EFM	CCMT060204N-SC	.250	.094	.0156	.110	●	●							
CCMT32.52EFM	CCMT090308N-SC	.375	.125	.0313	.1732	●	●							



CC

80° Diamond Type

7° Relief

With Insert Hole

- P Steel
- M Stainless Steel
- K Cast Iron
- N Non-ferrous
- S Exotic Materials
- H Hardened Steel

- USA Stocked Item
- ★ Worldwide Warehouse Item
- ▲ USA Limited Availability Item
- In stock by 1st Quarter 2017

CCMT ENK		Rake Angle: 8°	Cutting Conditions:						Coated				Cermet			Uncoated			
			Continuous Cut						Medium Cut				Interrupted Cut						
		Sumitomo Catalog #	ISO Catalog #	I.C.	T	r	ød1	AC8025P	AC820P	AC830P	AC700G								
CCMT21.51ENK	CCMT060204N-SK	.250	.094	.0156	.110	●	●	●	●										
CCMT21.52ENK	CCMT060208N-SK			.0313		●	●	●	●										
CCMT32.51ENK	CCMT09T304N-SK	.375	.156	.0156	.1732	●	●	●	●										
CCMT32.52ENK	CCMT09T308N-SK			.0313		●	●	●	●										
CCMT431ENK	CCMT120404N-SK	.500	.1875	.0156	.2165	●	●	●	●										
CCMT432ENK	CCMT120408N-SK			.0313		●	●	●	●										

CCMT ESU		Rake Angle: 8°	Cutting Conditions:						Coated										Cermet									
			Continuous Cut						Medium Cut										Interrupted Cut									
		Sumitomo Catalog #	ISO Catalog #	I.C.	T	r	ød1	AC810P	AC8025P	AC820P	AC830P	AC700G	AC530U	AC610M	AC6020M	AC6030M	AC6040M	AC630M	AC405K	AC410K	AC415K	AC420K	AC510U	AC520U	T1500Z	T2000Z	T3000Z	T1500A
CCMT21.50.5ESU	CCMT060202N-SU			.0078		●	●	●	●	●	●	●	●	●	●	●	●	●	●	●	●	●	●	●	●	●	●	●
CCMT21.51ESU	CCMT060204N-SU	.250	.094	.0156	.110	●	●	●	●	●	●	●	●	●	●	●	●	●	●	●	●	●	●	●	●	●	●	▲
CCMT21.52ESU	CCMT060208N-SU			.0313		●	●	●	●	●	●	●	●	●	●	●	●	●	●	●	●	●	●	●	●	●	●	▲
CCMT32.50.5ESU	CCMT09T302N-SU			.0078		●	●	●	●	●	●	●	●	●	●	●	●	●	●	●	●	●	●	●	●	●	●	●
CCMT32.51ESU	CCMT09T304N-SU	.375	.156	.0156	.1732	●	●	●	●	●	●	●	●	●	●	●	●	●	●	●	●	●	●	●	●	●	●	▲
CCMT32.52ESU	CCMT09T308N-SU			.0313		●	●	●	●	●	●	●	●	●	●	●	●	●	●	●	●	●	●	●	●	●	●	▲
CCMT431ESU	CCMT120404N-SU	.500	.1875	.0156	.2165	●	●	●	●	●	●	●	●	●	●	●	●	●	●	●	●	●	●	●	●	●	●	▲
CCMT432ESU	CCMT120408N-SU			.0313		●	●	●	●	●	●	●	●	●	●	●	●	●	●	●	●	●	●	●	●	●	●	▲



Positive Inserts

C

D

R

S

T

V

W

Swiss Tooling

80° DIAMOND TYPE

POSITIVE INSERT

Indexable Inserts for Turning

CC 80° Diamond Type
7° Relief
With Insert Hole

- P** Steel
- M** Stainless Steel
- K** Cast Iron
- N** Non-ferrous
- S** Exotic Materials
- H** Hardened Steel

- USA Stocked Item
- ★ Worldwide Warehouse Item
- ▲ USA Limited Availability Item
- In stock by 1st Quarter 2017

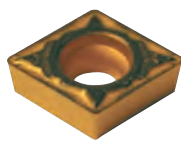
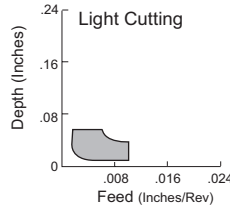
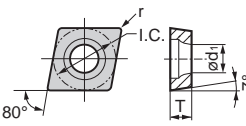
CCMT ELU		Rake Angle: 12°	Cutting Conditions:		Coated						Cermet			Uncoated			
			Continuous Cut	Medium Cut	Interrupted Cut	●	●	●	●	●	●	●	●	●			
		 <p>Depth (Inches)</p> <p>Feed (Inches/Rev)</p>			AC810P	AC8025P	AC820P	AC700G	AC6030M	AC630M							
					●	●	●	●	●	●							
Sumitomo Catalog #	ISO Catalog #	I.C.	T	r	ød1												
CCMT21.50.5ELU	CCMT060202N-LU	.250	.094	.0078	.110	●	●	●	●	●	●						
CCMT21.51ELU	CCMT060204N-LU			.0156		●	●	●	●	●	●						
CCMT32.51ELU	CCMT09T304N-LU	.375	.156	.0156	.1732	●	●	●	●	●	●						
CCMT32.52ELU	CCMT09T308N-LU			.0313		●	●	●	●	●	●						

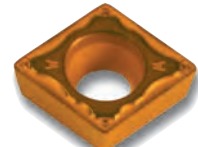
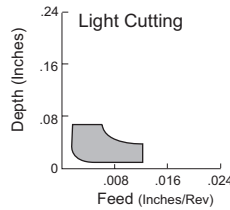
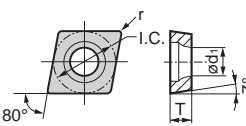
CCMT ELUW Wiper Insert		Rake Angle: 12°	Cutting Conditions:		Coated						Cermet			Uncoated			
			Continuous Cut	Medium Cut	Interrupted Cut	●	●	●	●	●	●	●	●	●			
		 <p>Depth (Inches)</p> <p>Feed (Inches/Rev)</p>			AC810P	AC8025P	AC820P	AC700G	AC405K	AC415K							
					●	●	●	●	●	●							
Sumitomo Catalog #	ISO Catalog #	I.C.	T	r	ød1												
CCMT32.51ELUW	CCMT09T304N-LUW	.375	.156	.0156	.1732	●	●	●	●	●	●						
CCMT32.52ELUW	CCMT09T308N-LUW			.0313		●	●	●	●	●	●						

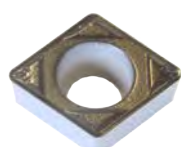
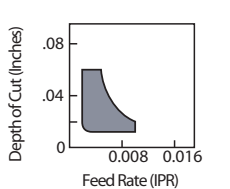
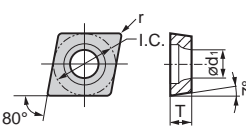
CCMT ELB		Rake Angle: 15°	Cutting Conditions:		Coated						Cermet			Uncoated			
			Continuous Cut	Medium Cut	Interrupted Cut	●	●					●	●	●			
		 <p>Depth of Cut (Inches)</p> <p>Feed Rate (IPR)</p>			AC8025P	AC6020M											
					●	●											
Sumitomo Catalog #	ISO Catalog #	I.C.	T	r	ød1												
CCMT21.50.5ELB	CCMT060202N-LB			.0078		●	●										
CCMT21.51ELB	CCMT060204N-LB	.250	.094	.0156	.110	●	●										
CCMT21.52ELB	CCMT060208N-LB			.0313		●	●										
CCMT32.50.5ELB	CCMT09T302N-LB			.0078		●	●										
CCMT32.51ELB	CCMT09T304N-LB	.375	.156	.0156	.1732	●	●										
CCMT32.52ELB	CCMT09T308N-LB			.0313		●	●										



CC

80° Diamond Type

7° Relief

With Insert Hole

- P Steel
- M Stainless Steel
- K Cast Iron
- N Non-ferrous
- S Exotic Materials
- H Hardened Steel

- USA Stocked Item
- ★ Worldwide Warehouse Item
- ▲ USA Limited Availability Item
- In stock by 1st Quarter 2017

CCMT EMU		Rake Angle: 0°	Cutting Conditions:						Coated						Cermet	Uncoated					
			Continuous Cut						●	●	●	●	●	●	●	●	●	●	●	●	
			Medium Cut						●	●	●	●	●	●	●	●	●	●	●	●	●
			Interrupted Cut						●	●	●	●	●	●	●	●	●	●	●	●	●
				AC810P	AC8025P	AC820P	AC830P	AC700G	AC6020M	AC6030M	AC405K	AC410K	AC415K	AC420K							
Sumitomo Catalog #	ISO Catalog #	I.C.	T	r	ød1																
CCMT32.51EMU	CCMT09T304N-MU	.375	.156	.0156	.1732	●	●	●	●	●	●	●	●	●							
CCMT32.52EMU	CCMT09T308N-MU	.375	.156	.0313	.1732	●	●	●	●	○	★	●	▲	●	●						

CCMA —		Rake Angle: 0°	Cutting Conditions:						Coated						Cermet	Uncoated							
			Continuous Cut						●	●	●												
			Medium Cut						●	●	●												
			Interrupted Cut						●														
			AC700G	AC405K	AC415K	AC420K																	
Sumitomo Catalog #	ISO Catalog #	I.C.	T	r	ød1																		
CCMA21.51	CCMA060204	.250	.094	.0156	.110	●	●	●	●														
CCMA32.51	CCMA09T304	.375	.156	.0156	.1732	●	●	●	●	●													
CCMA32.52	CCMA09T308	.375	.156	.0313	.1732	●	●	●	●	●													



Positive Inserts

C

D

R

S

T

V

W

Swiss Tooling

80° DIAMOND TYPE

POSITIVE INSERT

Indexable Inserts for Turning

CP

80° Diamond Type

11° Relief

With Insert Hole

- P Steel
- M Stainless Steel
- K Cast Iron
- N Non-ferrous
- S Exotic Materials
- H Hardened Steel

- USA Stocked Item
- ★ Worldwide Warehouse Item
- ▲ USA Limited Availability Item
- In stock by 1st Quarter 2017

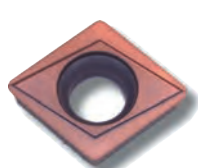
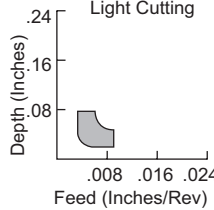
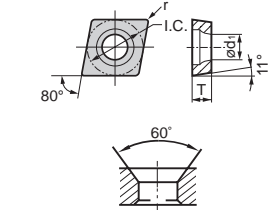
CPGT		Rake Angle: 0°	Cutting Conditions:						Coated			Cermet			Uncoated								
—			Continuous Cut						●				●	●	●	●	●	●					
			Medium Cut						●	●			●	●	●	●	●	●	●	●			
			Interrupted Cut						●				●	●	●								
		<p>Light Cutting</p>  <p>Depth (Inches)</p> <p>Feed (Inches/Rev)</p>							●	●				●	●	●	●	●	●	●	●		
Sumitomo Catalog #	ISO Catalog #	I.C.	T	r	ød1	AC510U	AC520U					T1500Z	T2000Z	T3000Z	T1500A	T1200A	G10E	EH510					
CPGT2.51.50.5	CPGT080202N-SD			.0078		●	●					●	●	●	●	▲	●	●					
CPGT2.51.51	CPGT080204N-SD	.3125	.094	.0156	.134	●	●					●	●	●	●	▲	●	●					
CPGT2.51.52	CPGT080208N-SD			.0313		●	●					●	●	●	●	▲	●	●					
CPGT320.5	CPGT090302N-SD			.0078		●	●					●	●	●	●	▲	●	●					
CPGT321	CPGT090304N-SD	.375	.125	.0156	.1732	●	●					●	●	●	●	▲	●	●					
CPGT322	CPGT090308N-SD			.0313		●	●					●	●	●	●	▲	●	●					
CPGT430.5	CPGT120402N-SD			.0078		●	●					●	●	●	●	▲	●	●					
CPGT431	CPGT120404N-SD	.500	.1875	.0156	.2165	●	●					●	●	●	●	▲	●	●					
CPGT432	CPGT120408N-SD			.0313		●	●					●	●	●	●	▲	●	●					

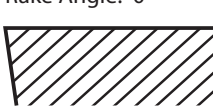
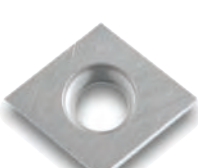
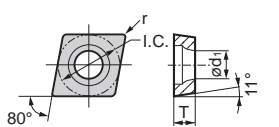
CPEW		Rake Angle: 0°	Cutting Conditions:						Coated			Cermet			Uncoated							
—			Continuous Cut											●								
			Medium Cut											●								
			Interrupted Cut																			
														●								
Sumitomo Catalog #	ISO Catalog #	I.C.	T	r	ød1							H1										
CPEW1.81.51	CPEW050204	.219		.0156	.102							●										
CPEW21.51	CPEW060204	.250	.094	.0156	.110							●										
CPEW32.51	CPEW09T304	.375	.156	.0156	.1732							●										
CPEW32.52	CPEW09T308			.0313								●										
CPEW432	CPEW120408	.500	.1875	.0313	.2165							●										



CP

80° Diamond Type

11° Relief

With Insert Hole

- P** Steel
- M** Stainless Steel
- K** Cast Iron
- N** Non-ferrous
- S** Exotic Materials
- H** Hardened Steel

- USA Stocked Item
- ★ Worldwide Warehouse Item
- ▲ USA Limited Availability Item
- In stock by 1st Quarter 2017

CPMT EFB		Rake Angle: 20°	Cutting Conditions:						Coated			Cermet	Uncoated	
			Continuous Cut									●		
			Medium Cut									●		
			Interrupted Cut									●		
									● T1500A					
Sumitomo Catalog #	ISO Catalog #	I.C.	T	r	ød1									
CPMT2.51.51EFB	CPMT080204N-FB	.3125	.094	.0156	.1732									

CPMT ENS (ENX)		Rake Angle: 10°	Cutting Conditions:						Coated	Cermet	Uncoated	
			Continuous Cut						● ●			
			Medium Cut						● ●			
			Interrupted Cut						● ●			
									AC6030M AC630M			
Sumitomo Catalog #	ISO Catalog #	I.C.	T	r	ød1							
CPMT21.51ENS	CPMT060204N-US	.250		.0156	.110							
CPMT2.51.52ENS	CPMT080208N-US	.3125	.094	.0313	.134							
CPMT322ENS	CPMT090308N-US	.375	.125	.0313	.1732							
CPMT432ENS	CPMH120408N-US	.500	.1875	.0313	.2165							

CPMT ELU		Rake Angle: 12°	Cutting Conditions:						Coated			Cermet	Uncoated
			Continuous Cut						● ● ● ● ● ●			● ●	
			Medium Cut						● ● ● ● ● ●			● ● ● ●	
			Interrupted Cut						● ● ● ● ● ●			● ●	
									AC810P AC8025P AC820P AC700G AC6030M AC630M				
Sumitomo Catalog #	ISO Catalog #	I.C.	T	r	ød1								
CPMT321ELU	CPMT090304N-LU	.375	.125	.0156	.1732								
CPMT322ELU	CPMT090308N-LU			.0313									



Positive Inserts

C

D

R

S

T

V

W

Swiss Tooling

CP

80° Diamond Type



11° Relief

With Insert Hole

- P** Steel
- M** Stainless Steel
- K** Cast Iron
- N** Non-ferrous
- S** Exotic Materials
- H** Hardened Steel

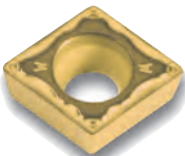
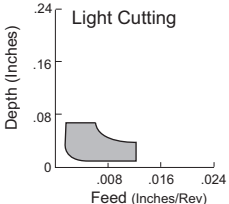
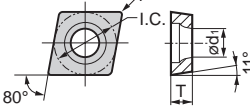
- USA Stocked Item
- ★ Worldwide Warehouse Item
- ▲ USA Limited Availability Item
- In stock by 1st Quarter 2017

CPMT ELUW Wiper Insert		Rake Angle: 12°		Cutting Conditions:						Coated			Cermet			Uncoated		
				Continuous Cut														
				Medium Cut														
				Interrupted Cut														
		 <p>Light Cutting</p>								AC810P			T1500Z					
Sumitomo Catalog #		ISO Catalog #		I.C.	T	r	ød1	AC820P	AC700G									
CPMT321ELUW		CPMT090304N-LUW		.375	.125	.0156	.1732	★	★					★				
CPMT322ELUW		CPMT090308N-LUW				.0313		★	★	●				★	●	●		

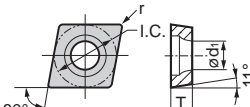
CPMA		Rake Angle: 0°		Cutting Conditions:						Coated			Cermet			Uncoated		
				Continuous Cut														
				Medium Cut														
				Interrupted Cut														
										AC700G								
Sumitomo Catalog #		ISO Catalog #		I.C.	T	r	ød1	AC410K	AC415K	AC420K								
CPMA2.51.51		CPMA080204		.3125	.094	.0156	.134				●							
CPMA2.51.52		CPMA080208				.0313												
CPMA321		CPMA090304		.375	.125	.0156	.1732	★	▲	●	●	●						
CPMA322		CPMA090308				.0313		▲	●	●								

Positive Inserts

C

D

R

S

T

V

W

Swiss Tooling



55° DIAMOND TYPE

POSITIVE INSERT

Indexable Inserts for Turning

DC

55° Diamond Type

7° Relief

With Insert Hole

- P** Steel
- M** Stainless Steel
- K** Cast Iron
- N** Non-ferrous
- S** Exotic Materials
- H** Hardened Steel

- USA Stocked Item
- ★ Worldwide Warehouse Item
- ▲ USA Limited Availability Item
- In stock by 1st Quarter 2017

DCGT FX

Rake Angle: 15°



Cutting Conditions:

Continuous Cut

Medium Cut

Interrupted Cut

Coated

Cermet

Uncoated

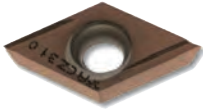
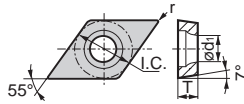
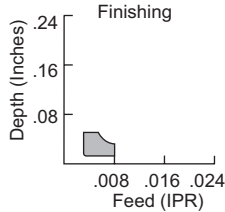

Sumitomo Catalog #	ISO Catalog #	I.C.	T	r	ød1	AC530U	ACZ310	TI1500A	TI200A
DCGT21.5.001RFX	DCGT0702003R-FX	.250	.094	.0012	.110	●		★	▲
DCGT21.5.001LFX	DCGT0702003L-FX			.0012		★	▲		
DCGT21.50RFX	DCGT070201R-FX			.0039		★	▲		
DCGT21.50LFX	DCGT070201L-FX			.0039		●	★	▲	
DCGT21.50.5RFX	DCGT070202R-FX			.0078		●	★	▲	
DCGT21.50.5LFX	DCGT070202L-FX			.0078		★	▲		
DCGT32.5.001RFX	DCGT11T3003R-FX	.375	.156	.0012	.1732	★	▲	★	▲
DCGT32.5.001LFX	DCGT11T3003L-FX			.0012		★	▲		
DCGT32.50RFX	DCGT11T301R-FX			.0039		★	▲		
DCGT32.50LFX	DCGT11T301L-FX			.0039		★	▲		
DCGT32.50.5RFX	DCGT11T302R-FX			.0078		★	▲		
DCGT32.50.5LFX	DCGT11T302L-FX			.0078		★	▲		

DCGT FY

Rake Angle: 15°



Cutting Conditions:

Continuous Cut

Medium Cut

Interrupted Cut

Coated

Cermet

Uncoated

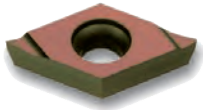
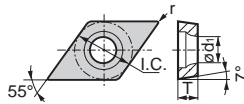
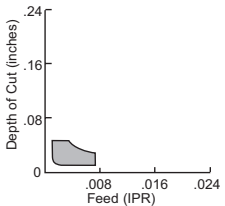

Sumitomo Catalog #	ISO Catalog #	I.C.	T	r	ød1	AC530U	ACZ310
DCGT21.5.001RFY	DCGT0702003R-FY	.250	.094	.0012	.110	★	▲
DCGT21.50.5LFY	DCGT070202L-FY			.0078		★	▲
DCGT21.51RFY	DCGT070204R-FY			.0156		★	
DCGT21.51LFY	DCGT070204L-FY			.0156		★	
DCGT32.50.5RFY	DCGT11T302R-FY			.0078		★	▲
DCGT32.50LFY	DCGT11T301L-FY			.0039		★	▲
DCGT32.51LFY	DCGT11T304L-FY	.0156	★	▲			



DC

55° Diamond Type

7° Relief

With Insert Hole

- P Steel
- M Stainless Steel
- K Cast Iron
- N Non-ferrous
- S Exotic Materials
- H Hardened Steel

- USA Stocked Item
- ★ Worldwide Warehouse Item
- ▲ USA Limited Availability Item
- In stock by 1st Quarter 2017

DCGT W		Rake Angle: 10°	Cutting Conditions:				Coated		Cermet		Uncoated		
			Continuous Cut Medium Cut Interrupted Cut				●	●	●	●	●	●	
							T1500A		T1200A				
Sumitomo Catalog #	ISO Catalog #	I.C.	T	r	ød1								
DCGT21.50.5R	DCGT070202R-W	.250	.094	.0078	.110	★	★						
DCGT21.50.5L	DCGT070202L-W			.0078		★	★						
DCGT21.51R	DCGT070204R-W			.0156		★	▲						
DCGT21.51L	DCGT070204L-W			.0156		★	▲						
DCGT32.51R	DCGT11T304R-W	.375	.156	.0156	.1732	●	▲						
DCGT32.51L	DCGT11T304L-W			.0156		★	▲						
DCGT32.52R	DCGT11T308R-W			.0313		★	▲						
DCGT32.52L	DCGT11T308L-W			.0313		★	▲						

DCGT EFM		Rake Angle: 6°	Cutting Conditions:				Coated		Cermet				Uncoated					
			Continuous Cut Medium Cut Interrupted Cut				●	○	●	●	●	●	●	●				
							AC530U ACZ310		T1500Z		Z2000Z		Z3000Z		V000A V000A			
Sumitomo Catalog #	ISO Catalog #	I.C.	T	r	ød1													
DCGT21.5.001EFM	DCGT0702003N-SC	.250	.094	.0012	.110	★	▲											
DCGT21.50EFM	DCGT070201N-SC			.0039		●	▲											
DCGT21.50MEFM	DCGT070201MN-SC			.0039		●	●											
DCGT21.50.5EFM	DCGT070202N-SC			.0078		★	▲											
DCGT21.50.5MEFM	DCGT070202MN-SC			.0078		★	▲											
DCGT21.51EFM	DCGT070204N-SC			.0156		●	●											
DCGT21.51MEFM	DCGT070204MN-SC			.0156		●	●											
DCGT21.52EFM	DCGT070208N-SC			.0313		●	●											
DCGT21.52MEFM	DCGT070208MN-SC			.0313		●	●											
DCGT2.51.50EFM	DCGT090201N-SC			.3125		.134	.0039											
DCGT2.51.50.5EFM	DCGT090202N-SC						.0078	★	▲									
DCGT32.5.001EFM	DCGT11T3003N-SC			.375		.156	.0012	.1732	★	▲								
DCGT32.50EFM	DCGT11T301N-SC	.0039	●		▲													
DCGT32.50MEFM	DCGT11T301MN-SC	.0039	●		●													
DCGT32.50.5EFM	DCGT11T302N-SC	.0078	●		▲													
DCGT32.50.5MEFM	DCGT11T302MN-SC	.0078	●		▲													
DCGT32.51EFM	DCGT11T304N-SC	.0156	●		▲													
DCGT32.51MEFM	DCGT11T304MN-SC	.0156	●		▲													
DCGT32.52EFM	DCGT11T308N-SC	.0313	●		▲													
DCGT32.52MEFM	DCGT11T308MN-SC	.0313	●		▲													

M = Negative nose radius tolerance (-0.0001" to -0.0004")



Positive Inserts



Swiss Tooling

55° DIAMOND TYPE

POSITIVE INSERT

Indexable Inserts for Turning

DC

55° Diamond Type

7° Relief

With Insert Hole

- P Steel
- M Stainless Steel
- K Cast Iron
- N Non-ferrous
- S Exotic Materials
- H Hardened Steel

- USA Stocked Item
- ★ Worldwide Warehouse Item
- ▲ USA Limited Availability Item
- In stock by 1st Quarter 2017

DCGT NAG		Rake Angle: 20°	Cutting Conditions:			Coated		Cermet		Uncoated					
			Continuous Cut							●					
			Medium Cut							●					
			Interrupted Cut												
Sumitomo Catalog #	ISO Catalog #	I.C.	T	r	ød1					H1					
DCGT21.50.5NAG	DCGT070202N-AG	.250	.094	.0078	.110					●					
DCGT21.51NAG	DCGT070204N-AG			.0156						●					
DCGT32.50.5NAG	DCGT11T302N-AG			.0078						●					
DCGT32.51NAG	DCGT11T304N-AG	.375	.156	.0156	.1732					●					
DCGT32.52NAG	DCGT11T308N-AG			.0313						●					

DCGT EFC		Rake Angle: 15°	Cutting Conditions:			Coated		Cermet		Uncoated					
			Continuous Cut			●		●							
			Medium Cut			●	●	●							
			Interrupted Cut			●	●	●							
Sumitomo Catalog #	ISO Catalog #	I.C.	T	r	ød1	AC530U	AC520U	T1500A							
DCGT21.5.001EFC	DCGT0702003N-FC			.0012		●									
DCGT21.50EFC	DCGT070201N-FC			.0039		●									
DCGT21.50MEFC	DCGT070201MN-FC			.0039	.110	●				●					
DCGT21.50.5EFC	DCGT070202N-FC	.250	.094	.0078		●				●					
DCGT21.50.5MEFC	DCGT070202MN-FC			.0078		●				●					
DCGT21.51EFC	DCGT070204N-FC			.0156	.134	●				●					
DCGT21.51MEFC	DCGT070204MN-FC			.0156		●				●					
DCGT32.5.001EFC	DCGT11T3003N-FC			.0012		●				●					
DCGT32.50EFC	DCGT11T301N-FC			.0039		●				●					
DCGT32.50MEFC	DCGT11T301MN-FC			.0039	.1732	●	●			●					
DCGT32.50.5EFC	DCGT11T302N-FC	.375	.156	.0078		●	●			●					
DCGT32.50.5MEFC	DCGT11T302MN-FC			.0078		●	●			●					
DCGT32.51EFC	DCGT11T304N-FC			.0156		●	●			●					
DCGT32.51MEFC	DCGT11T304MN-FC			.0156		●	●			●					

M = Negative nose radius tolerance (-0.0001" to -0.0004")



DC



55° Diamond Type

7° Relief



With Insert Hole

- P Steel
- M Stainless Steel
- K Cast Iron
- N Non-ferrous
- S Exotic Materials
- H Hardened Steel

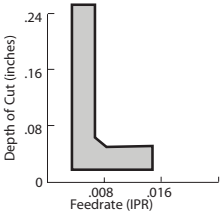
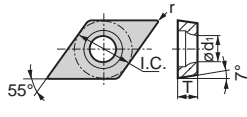
- USA Stocked Item
- ★ Worldwide Warehouse Item
- ▲ USA Limited Availability Item
- In stock by 1st Quarter 2017

DCGT ESI		Rake Angle: 15°	Cutting Conditions:						Coated			Cermet		Uncoated					
									Continuous Cut	Medium Cut	Interrupted Cut								
									●	●	●	●	●	●	●	●	●	●	●
Sumitomo Catalog #	ISO Catalog #	I.C.	T	r	ød1	AC530U	AC610M	AC6030M	AC630M	AC510U	AC520U	T1500Z	T1500A						
DCGT21.50MESI	DCGT070201MN-SI			.0039		●	●	●	●	●	●	●	●						
DCGT21.50.5MESI	DCGT070202MN-SI	.250	.094	.0078	.110	●	●	●	●	●	●	●	●						
DCGT21.51MESI	DCGT070204MN-SI			.0156		●	●	●	●	●	●	●	●						
DCGT32.50MESI	DCGT11T301MN-SI			.0039		●	●	●	●	●	●	●	●						
DCGT32.50.5MESI	DCGT11T302MN-SI	.375	.156	.0078	.1732	●	●	●	●	●	●	●	●						
DCGT32.51MESI	DCGT11T304MN-SI			.0156		●	●	●	●	●	●	●	●						
DCGT32.52MESI	DCGT11T308MN-SI			.0313		●	●	●	●	●	●	●	●						

M = Negative nose radius tolerance (-0.0001" to -0.0004")

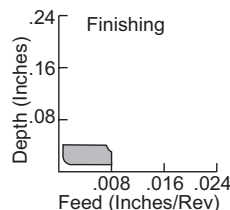
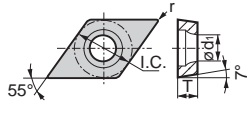
DCMT EFB		Rake Angle: 20°	Cutting Conditions:						Coated			Cermet		Uncoated					
									Continuous Cut	Medium Cut	Interrupted Cut								
									●	●	●	●	●	●	●	●	●	●	
Sumitomo Catalog #	ISO Catalog #	I.C.	T	r	ød1	AC530U	AC610M	AC6030M	AC630M	AC510U	AC520U	T1500Z	T1500A						
DCMT21.50.5EFB	DCMT070202N-FB			.0078		●	●	●	●	●	●	●	●						
DCMT21.51EFB	DCMT070204N-FB	.250	.094	.0156	.110	●	●	●	●	●	●	●	●						
DCMT21.52EFB	DCMT070208N-FB			.0313		●	●	●	●	●	●	●	●						
DCMT32.50.5EFB	DCMT11T302N-FB			.0078		●	●	●	●	●	●	●	●						
DCMT32.51EFB	DCMT11T304N-FB	.375	.156	.0156	.1732	●	●	●	●	●	●	●	●						
DCMT32.52EFB	DCMT11T308N-FB			.0313		●	●	●	●	●	●	●	●						



Positive Inserts

C

D

R

S

T

V

W

Swiss Tooling

55° DIAMOND TYPE

POSITIVE INSERT

Indexable Inserts for Turning

DC

55° Diamond Type

7° Relief

With Insert Hole

- P** Steel
- M** Stainless Steel
- K** Cast Iron
- N** Non-ferrous
- S** Exotic Materials
- H** Hardened Steel

- USA Stocked Item
- ★ Worldwide Warehouse Item
- ▲ USA Limited Availability Item
- In stock by 1st Quarter 2017

Positive Inserts

C

D

R

S

T

V

W

Swiss Tooling

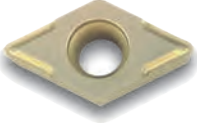
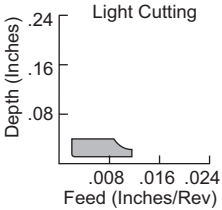
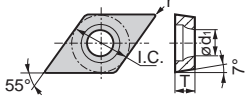
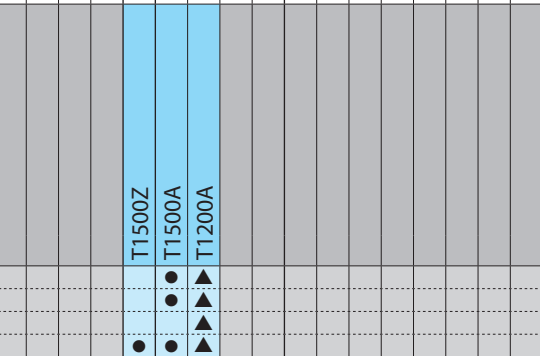
DCMT EFP		Rake Angle: 10°	Cutting Conditions:				Coated			Cermet			Uncoated		
			Continuous Cut	Medium Cut	Interrupted Cut										
															
Sumitomo Catalog #	ISO Catalog #	I.C.	T	r	ød1										
DCMT21.50.5EFP	DCMT070202N-FP	.250	.094	.0078	.110										
DCMT21.51EFP	DCMT070204N-FP			.0156											
DCMT32.51EFP	DCMT11T304N-FP			.0156											
DCMT32.52EFP	DCMT11T308N-FP	.375	.156	.0313	.1732										

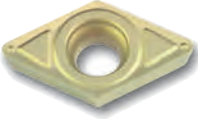
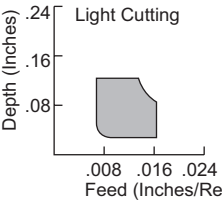
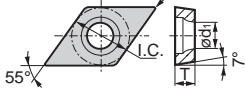
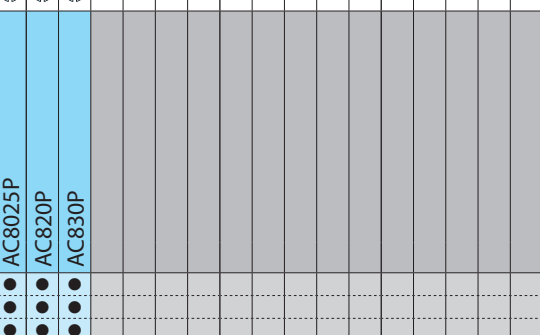
DCMT ENK		Rake Angle: 8°	Cutting Conditions:				Coated			Cermet			Uncoated		
			Continuous Cut	Medium Cut	Interrupted Cut										
															
Sumitomo Catalog #	ISO Catalog #	I.C.	T	r	ød1										
DCMT21.51ENK	DCMT070204N-SK	.250	.094	.0156	.110										
DCMT32.51ENK	DCMT11T304N-SK			.0156											
DCMT32.52ENK	DCMT11T308N-SK	.375	.156	.0313	.1732										

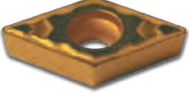
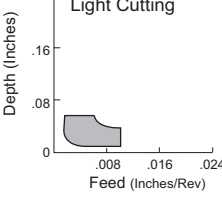
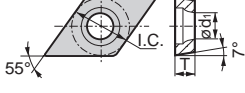
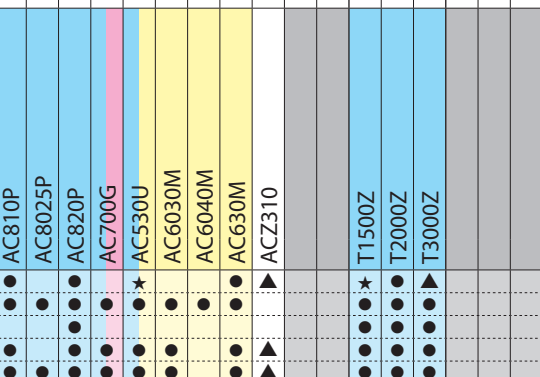
DCMT ELU		Rake Angle: 15°	Cutting Conditions:				Coated						Cermet			Uncoated		
			Continuous Cut	Medium Cut	Interrupted Cut													
																		
Sumitomo Catalog #	ISO Catalog #	I.C.	T	r	ød1													
DCMT21.50.5ELU	DCMT070202N-LU	.250	.094	.0078	.110													
DCMT21.51ELU	DCMT070204N-LU			.0156														
DCMT32.50.5ELU	DCMT11T302N-LU			.0078														
DCMT32.51ELU	DCMT11T304N-LU	.375	.156	.0156	.1732													
DCMT32.52ELU	DCMT11T308N-LU			.0313														



DC 55° Diamond Type
7° Relief
With Insert Hole

- P** Steel
- M** Stainless Steel
- K** Cast Iron
- N** Non-ferrous
- S** Exotic Materials
- H** Hardened Steel

- USA Stocked Item
- ★ Worldwide Warehouse Item
- ▲ USA Limited Availability Item
- In stock by 1st Quarter 2017

DCMT ESU		Rake Angle: 8°		Cutting Conditions:						Coated						Cermet														
				Continuous Cut	Medium Cut	Interrupted Cut	●	●	●	●	●	●	●	●	●	●	●	●	●	●	●	●								
		Light Cutting								AC810P	AC8025P	AC820P	AC830P	AC700G	AC530U	AC610M	AC6020M	AC6030M	AC6040M	AC630M	AC405K	AC410K	AC415K	AC510U	AC520U	T1500Z	T2000Z	T3000Z	T1500A	T1200A
Sumitomo Catalog #	ISO Catalog #	I.C.	T	r	ød1	●	●	●	●	●	●	●	●	●	●	●	●	●	●	●	●	●	●	●	●	●	●	●	●	
DCMT21.50.5ESU	DCMT070202N-SU	.250	.094	.0078	.110	●	●	●	●	●	●	●	●	●	●	●	●	●	●	●	●	●	●	●	●	●	●	●	●	
DCMT21.51ESU	DCMT070204N-SU			.0313		●	●	●	●	●	●	●	●	●	●	●	●	●	●	●	●	●	●	●	●	●	●	●	●	
DCMT21.52ESU	DCMT070208N-SU			.0078		●	●	●	●	●	●	●	●	●	●	●	●	●	●	●	●	●	●	●	●	●	●	●	●	
DCMT32.50.5ESU	DCMT11T302N-SU			.0078		●	●	●	●	●	●	●	●	●	●	●	●	●	●	●	●	●	●	●	●	●	●	●	●	
DCMT32.51ESU	DCMT11T304N-SU	.375	.156	.0156	.1732	●	●	●	●	●	●	●	●	●	●	●	●	●	●	●	●	●	●	●	●	●	●	●	●	
DCMT32.52ESU	DCMT11T308N-SU			.0313		●	●	●	●	●	●	●	●	●	●	●	●	●	●	●	●	●	●	●	●	●	●	●	●	

DCMT EMU		Rake Angle: 0°		Cutting Conditions:						Coated						Cermet		Uncoated											
				Continuous Cut	Medium Cut	Interrupted Cut	●	●	●	●	●	●	●	●	●	●	●	●	●	●	●	●							
		Medium Cutting								AC810P	AC8025P	AC820P	AC830P	AC700G	AC405K	AC410K	AC415K	AC420K	AC6020M										
Sumitomo Catalog #	ISO Catalog #	I.C.	T	r	ød1	●	●	●	●	●	●	●	●	●	●	●	●	●	●	●	●	●	●	●	●	●	●	●	●
DCMT32.51EMU	DCMT11T304N-MU	.375	.156	.0156	.1732	●	●	●	●	●	●	●	●	●	●	●	●	●	●	●	●	●	●	●	●	●	●	●	
DCMT32.52EMU	DCMT11T308N-MU			.0313		●	●	●	●	●	●	●	●	●	●	●	●	●	●	●	●	●	●	●	●	●	●	●	●

DCMA		No Breaker		Cutting Conditions:						Coated						Cermet		Uncoated												
				Continuous Cut	Medium Cut	Interrupted Cut	●	●	●	●	●	●	●	●	●	●	●	●	●	●	●	●								
										AC700G	AC405K	AC415K	AC420K																	
Sumitomo Catalog #	ISO Catalog #	I.C.	T	r	ød1	●	●	●	●	●	●	●	●	●	●	●	●	●	●	●	●	●	●	●	●	●	●	●	●	●
DCMA21.51	DCMA070204	.250	.094	.0156	.110	●	●	●	●	●	●	●	●	●	●	●	●	●	●	●	●	●	●	●	●	●	●	●	●	
DCMA21.52	DCMA070208			.0313		●	●	●	●	●	●	●	●	●	●	●	●	●	●	●	●	●	●	●	●	●	●	●	●	
DCMA32.51	DCMA11T304			.0156		●	●	●	●	●	●	●	●	●	●	●	●	●	●	●	●	●	●	●	●	●	●	●	●	
DCMA32.52	DCMA11T308	.375	.156	.0313	.1732	●	●	●	●	●	●	●	●	●	●	●	●	●	●	●	●	●	●	●	●	●	●	●	●	



Positive Inserts



Swiss Tooling

55° DIAMOND TYPE

POSITIVE INSERT

Indexable Inserts for Turning



DP

55° Diamond Type

11° Relief

With Insert Hole

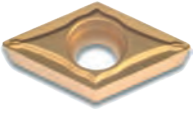
- P Steel
- M Stainless Steel
- K Cast Iron
- N Non-ferrous
- S Exotic Materials
- H Hardened Steel
- USA Stocked Item
- ★ Worldwide Warehouse Item
- ▲ USA Limited Availability Item
- In stock by 1st Quarter 2017

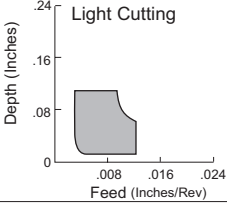
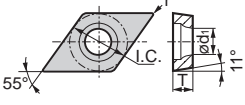
DPMT ESU		Rake Angle: 8°	Cutting Conditions:						Coated				Cermet		Uncoated			
			<p>Continuous Cut</p> <p>Medium Cut</p> <p>Interrupted Cut</p>						<p>● ● ● ●</p> <p>● ● ● ●</p> <p>● ● ● ●</p>				<p>● ●</p> <p>● ●</p> <p>● ●</p>		<p>● ●</p> <p>● ●</p> <p>● ●</p>		<p>● ●</p> <p>● ●</p> <p>● ●</p>	
								AC8025P	AC820P	AC510U	AC520U					T1200A		
Sumitomo Catalog #	ISO Catalog #	I.C.	T	r	ød1													
DPMT 21.51ESU	DPMT 070204N-SU	.250	.094	.0156	.110													
DPMT 32.51ESU	DPMT 11T304N-SU																	
DPMT 32.52ESU	DPMT 11T308N-SU	.375	.156	.0156 .0313	.1732													

Positive Inserts

C

D

R

S

T

V

W

Swiss Tooling



RC



Round Type



7° Relief

With Insert Hole

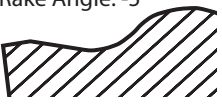
- P Steel
- M Stainless Steel
- K Cast Iron
- N Non-ferrous
- S Exotic Materials
- H Hardened Steel

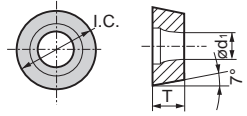
- USA Stocked Item
- ★ Worldwide Warehouse Item
- ▲ USA Limited Availability Item
- In stock by 1st Quarter 2017

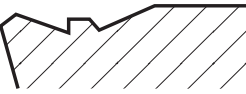
RCMT		Rake Angle: -5°	Cutting Conditions:						Coated			Cermet			Uncoated			
RX			Continuous Cut						●	●								
Medium Cut						●	●	●										
Interrupted Cut						●	●											
										AC810P	AC820P	AC830P						
Sumitomo Catalog #	ISO Catalog #	I.C.	T	r	ød1	●	●	●										
RCMT100300	RCMT1003M0N-RX	.394	.125		.1417	●	●	●										
RCMT120400	RCMT1204M0N-RX	.472	.1875		.1654	●	●	●										
RCMT160600	RCMT1606M0N-RX	.630		-	.2047	●	●	●										
RCMT200600	RCMT2006M0N-RX	.787	.250		.2559	●	●	●										
RCMT250700	RCMT2507M0N-RX	.984	.313		.2835	●	●	●										

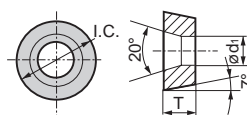
RCMX		Rake Angle: -15°	Cutting Conditions:						Coated						Uncoated				
RP			Continuous Cut						●	●	●	●	●	●					
Medium Cut						●	●	●	●	●	●	●							
Interrupted Cut						●	●	●	●	●	●								
										AC810P	AC820P	AC830P	AC700G	AC410K	AC415K	AC420K	AC510U		
Sumitomo Catalog #	ISO Catalog #	I.C.	T	r	ød1	●	●	●	●	▲	★	●	●						
RCMX100300	RCMX1003M0N-RP	.394	.125		.1417	●	●	●	●	▲	★	●	●						
RCMX120400	RCMX1204M0N-RP	.472	.1875		.1654	●	●	●	●	▲	★	●	●						
RCMX160600	RCMX1606M0N-RP	.630		-	.2047	●	●	●	●	▲	★	●	●						
RCMX200600	RCMX2006M0N-RP	.787	.250		.2559	●	●	●	●	▲	★	●	●						
RCMX250700	RCMX2507M0N-RP	.984	.313		.2835	●	●	●	●	▲	★	●	●						



Positive Inserts



Swiss Tooling

90° SQUARE TYPE

POSITIVE INSERT

Indexable Inserts for Turning

SC

90° Square Type

7° Relief

With Insert Hole

- P** Steel
- M** Stainless Steel
- K** Cast Iron
- N** Non-ferrous
- S** Exotic Materials
- H** Hardened Steel

- USA Stocked Item
- ★ Worldwide Warehouse Item
- ▲ USA Limited Availability Item
- In stock by 1st Quarter 2017

SCGT FX

Rake Angle: 15°



Cutting Conditions:

Continuous Cut

Medium Cut

Interrupted Cut

Coated

Cermet

Uncoated

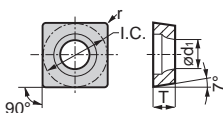
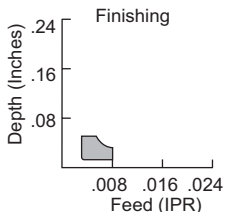
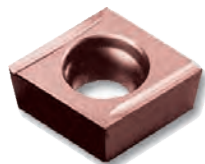

AC530U
ACZ310

Sumitomo Catalog #

ISO Catalog #

I.C.

T

r

ød1

Sumitomo Catalog #	ISO Catalog #	I.C.	T	r	ød1	AC530U	ACZ310	Coated	Cermet	Uncoated
SCGT32.50.5RFX	SCGT09T302R-FX	.375	.156	.0078	.1732	★	▲			
SCGT32.50.5LFX	SCGT09T302L-FX			.0078						
SCGT32.51RFX	SCGT09T304R-FX			.0156						
SCGT32.51LFX	SCGT09T304L-FX			.0156						

SCGT EFM

Rake Angle: 6°



Cutting Conditions:

Continuous Cut

Medium Cut

Interrupted Cut

Coated

Cermet

Uncoated

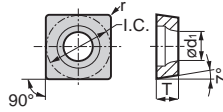
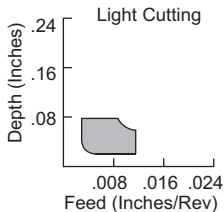
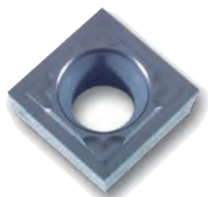

AC530U
ACZ310

T1500A
T1200A

Sumitomo Catalog #

ISO Catalog #

I.C.

T

r

ød1

Sumitomo Catalog #	ISO Catalog #	I.C.	T	r	ød1	AC530U	ACZ310	Coated	Cermet	Uncoated
SCGT2.51.50EFM	SCGT070201N-SC	.3125	.094	.0039	.134	★	▲			
SCGT2.51.50MEFM	SCGT070201MN-SC			.0039						
SCGT2.51.50.5EFM	SCGT070202N-SC			.0078						
SCGT2.51.50.5MEFM	SCGT070202MN-SC			.0078						
SCGT32.50EFM	SCGT09T301N-SC	.375	.156	.0039	.1732	★	▲			
SCGT32.50.5EFM	SCGT09T302N-SC			.0078						
SCGT32.50.5MEFM	SCGT09T302MN-SC			.0078						

M = Negative nose radius tolerance (-0.0001" to -0.0004")

SCMT EFB

Rake Angle: 20°



Cutting Conditions:

Continuous Cut

Medium Cut

Interrupted Cut

Coated

Cermet

Uncoated

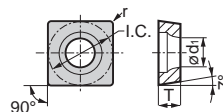
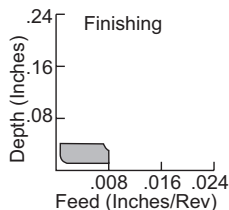
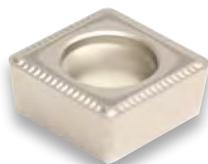

T1500Z
T1500A

Sumitomo Catalog #

ISO Catalog #

I.C.

T

r

ød1

Sumitomo Catalog #	ISO Catalog #	I.C.	T	r	ød1	T1500Z	T1500A	Coated	Cermet	Uncoated
SCMT32.51EFB	SCMT09T304N-FB	.375	.156	.0156	.1732	●	●			
SCMT32.52EFB	SCMT09T308N-FB			.0313			★			



SC

90° Square Type

7° Relief

With Insert Hole

- P** Steel
- M** Stainless Steel
- K** Cast Iron
- N** Non-ferrous
- S** Exotic Materials
- H** Hardened Steel

- USA Stocked Item
- ★ Worldwide Warehouse Item
- ▲ USA Limited Availability Item
- In stock by 1st Quarter 2017

SCMT EFP		Rake Angle: 10° 	Cutting Conditions:				Coated		Cermet		Uncoated	
			Continuous Cut	Medium Cut	Interrupted Cut							
 Light Cutting Depth (Inches) vs Feed (Inches/Rev) graph I.C. diagram		I.C.	T	r	ød1							
		Sumitomo Catalog #	ISO Catalog #									
SCMT32.51EFP	SCMT09T304N-FP	.375	.156	.0156 .0313	.1732			●	●			
SCMT32.52EFP	SCMT09T308N-FP							●	●			

SCMT ENK		Rake Angle: 8° 	Cutting Conditions:				Coated		Cermet		Uncoated	
			Continuous Cut	Medium Cut	Interrupted Cut							
 Light Cutting Depth (Inches) vs Feed (Inches/Rev) graph I.C. diagram		I.C.	T	r	ød1							
		Sumitomo Catalog #	ISO Catalog #									
SCMT32.51ENK	SCMT09T304N-SK	.375	.156	.0156 .0313	.1732	●	●	●				
SCMT32.52ENK	SCMT09T308N-SK					●	●	●				
SCMT431ENK	SCMT120404N-SK	.500	.1875	.0156 .0313	.2165	●	●	●				
SCMT432ENK	SCMT120408N-SK					●	●	●				
SCMT433ENK	SCMT120412N-SK			.0469		●	●	●				

SCMT ESU		Rake Angle: 8° 	Cutting Conditions:				Coated				Cermet		Uncoated	
			Continuous Cut	Medium Cut	Interrupted Cut									
 Light Cutting Depth (Inches) vs Feed (Inches/Rev) graph I.C. diagram		I.C.	T	r	ød1									
		Sumitomo Catalog #	ISO Catalog #											
SCMT32.51ESU	SCMT09T304N-SU	.375	.156	.0156 .0313	.1732	●	●	●	●	●	●	●	●	
SCMT32.52ESU	SCMT09T308N-SU					●	●	●	●	●	●	●	●	
SCMT431ESU	SCMT120404N-SU	.500	.1875	.0156 .0313	.2165	●	●	●	●	●	●	●	●	
SCMT432ESU	SCMT120408N-SU					●	●	●	●	●	●	●	●	



Positive Inserts



Swiss Tooling

90° SQUARE TYPE

POSITIVE INSERT

Indexable Inserts for Turning

SC

90° Square Type

7° Relief

With Insert Hole

- P** Steel
- M** Stainless Steel
- K** Cast Iron
- N** Non-ferrous
- S** Exotic Materials
- H** Hardened Steel

- USA Stocked Item
- ★ Worldwide Warehouse Item
- ▲ USA Limited Availability Item
- In stock by 1st Quarter 2017

Positive Inserts

C

D

R

S

T

V

W

Swiss Tooling

SCMT		Rake Angle: 12°		Cutting Conditions:		Coated					Cermet			Uncoated					
ELU				Continuous Cut		●	●	●	●	●					●	●			
				Medium Cut		●	●	●	●	●					●	●	●		
				Interrupted Cut			●	●	●	●							●		
						AC810P	AC8025P	AC820P	AC700G	AC630M					T1500Z	T2000Z	T3000Z		
Sumitomo Catalog #		ISO Catalog #		I.C.	T	r	ød1												
SCMT32.51ELU		SCMT09T304N-LU		.375	.156	.0156	.1732	●	●	●	●	●		●	●	●			
SCMT32.52ELU		SCMT09T308N-LU				.0313		●	●	●	●	●							

SCMT		Rake Angle: 15°		Cutting Conditions:		Coated					Cermet			Uncoated					
ELB				Continuous Cut		●	●												
				Medium Cut		●													
				Interrupted Cut		●													
						AC8025P	AC6020M												
Sumitomo Catalog #		ISO Catalog #		I.C.	T	r	ød1												
SCMT32.51ELB		SCMT09T304N-LB		.375	.156	.0156	.1732	●	○										
SCMT32.52ELB		SCMT09T308N-LB				.0313		●	○										



SC

90° Square Type

7° Relief

With Insert Hole

- P** Steel
- M** Stainless Steel
- K** Cast Iron
- N** Non-ferrous
- S** Exotic Materials
- H** Hardened Steel

- USA Stocked Item
- ★ Worldwide Warehouse Item
- ▲ USA Limited Availability Item
- In stock by 1st Quarter 2017

SCMT EMU		Rake Angle: 0° 	Cutting Conditions:						Coated				Cermet	Uncoated																																																	
			Continuous Cut	Medium Cut	Interrupted Cut	AC810P	AC8025P	AC820P	AC700G	AC405K	AC415K	AC420K	AC6020M																																																		
 		<table border="1"> <thead> <tr> <th>Sumitomo Catalog #</th> <th>ISO Catalog #</th> <th>I.C.</th> <th>T</th> <th>r</th> <th>ød1</th> <th>AC810P</th> <th>AC8025P</th> <th>AC820P</th> <th>AC700G</th> <th>AC405K</th> <th>AC415K</th> <th>AC420K</th> <th>AC6020M</th> <th></th> <th></th> </tr> </thead> <tbody> <tr> <td>SCMT32.52EMU</td> <td>SCMT09T308N-MU</td> <td>.375</td> <td>.156</td> <td>.0313</td> <td>.1732</td> <td>★</td> <td>●</td> <td>●</td> <td>●</td> <td>★</td> <td>★</td> <td>●</td> <td>○</td> <td></td> <td></td> </tr> <tr> <td>SCMT432EMU</td> <td>SCMT120408N-MU</td> <td>.500</td> <td>.1875</td> <td>.0313</td> <td>.2165</td> <td>★</td> <td>●</td> <td>●</td> <td>●</td> <td>★</td> <td>★</td> <td>●</td> <td>○</td> <td></td> <td></td> </tr> </tbody> </table>														Sumitomo Catalog #	ISO Catalog #	I.C.	T	r	ød1	AC810P	AC8025P	AC820P	AC700G	AC405K	AC415K	AC420K	AC6020M			SCMT32.52EMU	SCMT09T308N-MU	.375	.156	.0313	.1732	★	●	●	●	★	★	●	○			SCMT432EMU	SCMT120408N-MU	.500	.1875	.0313	.2165	★	●	●	●	★	★	●	○		
		Sumitomo Catalog #	ISO Catalog #	I.C.	T	r	ød1	AC810P	AC8025P	AC820P	AC700G	AC405K	AC415K	AC420K	AC6020M																																																
SCMT32.52EMU	SCMT09T308N-MU	.375	.156	.0313	.1732	★	●	●	●	★	★	●	○																																																		
SCMT432EMU	SCMT120408N-MU	.500	.1875	.0313	.2165	★	●	●	●	★	★	●	○																																																		

SCMA		No Breaker 	Cutting Conditions:						Coated		Cermet		Uncoated																																																														
			Continuous Cut	Medium Cut	Interrupted Cut	AC700G	AC420K																																																																				
 		<table border="1"> <thead> <tr> <th>Sumitomo Catalog #</th> <th>ISO Catalog #</th> <th>I.C.</th> <th>T</th> <th>r</th> <th>ød1</th> <th>AC700G</th> <th>AC420K</th> <th></th> <th></th> <th></th> <th></th> <th></th> <th></th> <th></th> </tr> </thead> <tbody> <tr> <td>SCMA32.52</td> <td>SCMA09T308</td> <td>.375</td> <td>.156</td> <td>.0313</td> <td>.1732</td> <td>●</td> <td>●</td> <td></td> <td></td> <td></td> <td></td> <td></td> <td></td> <td></td> </tr> <tr> <td>SCMA432</td> <td>SCMA120408</td> <td></td> <td></td> <td>.0313</td> <td></td> <td>★</td> <td>●</td> <td></td> <td></td> <td></td> <td></td> <td></td> <td></td> <td></td> </tr> <tr> <td>SCMA433</td> <td>SCMA120412</td> <td>.500</td> <td>.1875</td> <td>.0469</td> <td>.2165</td> <td>★</td> <td>●</td> <td></td> <td></td> <td></td> <td></td> <td></td> <td></td> <td></td> </tr> </tbody> </table>														Sumitomo Catalog #	ISO Catalog #	I.C.	T	r	ød1	AC700G	AC420K								SCMA32.52	SCMA09T308	.375	.156	.0313	.1732	●	●								SCMA432	SCMA120408			.0313		★	●								SCMA433	SCMA120412	.500	.1875	.0469	.2165	★	●							
		Sumitomo Catalog #	ISO Catalog #	I.C.	T	r	ød1	AC700G	AC420K																																																																		
SCMA32.52	SCMA09T308	.375	.156	.0313	.1732	●	●																																																																				
SCMA432	SCMA120408			.0313		★	●																																																																				
SCMA433	SCMA120412	.500	.1875	.0469	.2165	★	●																																																																				

- Positive Inserts
- C
- D
- R
- S
- T
- V
- W
- Swiss Tooling



90° SQUARE TYPE

POSITIVE INSERT

Indexable Inserts for Turning

SP

90° Square Type

11° Relief

- P Steel
 - M Stainless Steel
 - K Cast Iron
 - N Non-ferrous
 - S Exotic Materials
 - H Hardened Steel
- USA Stocked Item
 - ★ Worldwide Warehouse Item
 - ▲ USA Limited Availability Item
 - In stock by 1st Quarter 2017

SPGG SD		Rake Angle: 10°	Cutting Conditions:				Coated		Cermets		Uncoated		
			Continuous Cut						●	●	●	●	
			Medium Cut						●	●	●	●	
			Interrupted Cut								●	●	●
									T1500Z	T2000Z	T3000Z	T1500A	T1200A
Sumitomo Catalog #	ISO Catalog #	I.C.	T	r	ød1								
SPGG320.5L	SPGT090302L-SD			.0078									
SPGG321L	SPGT090304L-SD	.375	.125	.0156	.130			★	★	★	★	★	
SPGG322L	SPGT090308L-SD			.0313				★	●	★	★	▲	

SPG -		No Breaker	Cutting Conditions:				Coated		Cermets		Uncoated					
			Continuous Cut				●	●	●	●	●	●				
			Medium Cut				●	●	●	●	●	●	●			
			Interrupted Cut				●	●	●	●	●	●	●			
								AC8025P	AC820P	AC510U	EH20Z	T1500Z	T2000Z	T1500A	T1200A	G10E
Sumitomo Catalog #	ISO Catalog #	I.C.	T	r	ød1											
SPG321	SPGN090304			.0156												
SPG322	SPGN090308	.375		.0313												
SPG421	SPGN120304			.0156												
SPG422	SPGN120308		.125	.0313												
SPG423	SPGN120312			.0469												
SPG424	SPGN120316			.0625												
SPG432	SPGN120408	.500		.0313												
SPG433	SPGN120412			.0469												
SPG632	SPGN190408		.1875	.0313												
SPG633	SPGN190412	.750		.0469												
SPG634	SPGN190416			.0625												



SP

90° Square Type

11° Relief

With Insert Hole

- P** Steel
- M** Stainless Steel
- K** Cast Iron
- N** Non-ferrous
- S** Exotic Materials
- H** Hardened Steel

- USA Stocked Item
- ★ Worldwide Warehouse Item
- ▲ USA Limited Availability Item
- In stock by 1st Quarter 2017

SPMT ENS (ENX)		Rake Angle: 10° 	Cutting Conditions:						Coated			Cermet			Uncoated			
			Continuous Cut	Medium Cut	Interrupted Cut	●	●	●	●	●	●	●	●	●	●	●	●	
		<p>Light Cutting</p>						AC6030M AC6040M AC630M			A30							
																	Sumitomo Catalog #	ISO Catalog #
SPMT21.51ENS		SPMT060204N-US	.250	.094	.0156	.1102	●	●	●									
SPMT2.522ENS		SPMT070308N-US	.3125	.125	.0313	.134	●	●	●									
SPMT322ENS		SPMT090308N-US	.375	.125	.0313	.130	●	●	●									
SPMT32.52ENX		SPMT09T308N-US	.375	.156	.0313	.1732	●	●	●									
SPMT432ENS		SPMT120408N-US	.500	.1875	.0313	.2165	●	●	●									

SPMT ENF		Rake Angle: 0° 	Cutting Conditions:						Coated			Cermet			Uncoated			
			Continuous Cut	Medium Cut	Interrupted Cut	●	●	●	●	●	●	●	●	●	●	●	●	
		<p>Light Cutting</p>			AC820P AC830P													
																	Sumitomo Catalog #	ISO Catalog #
SPMT321ENF		SPMR090304N-NF	.375	.125	.0156	-	●	●	●									
SPMT322ENF		SPMR090308N-NF			.0313		●	●	●									

Positive Inserts

C

D

R

S

T

V

W

Swiss Tooling



90° SQUARE TYPE

POSITIVE INSERT

Indexable Inserts for Turning

SP

90° Square Type

11° Relief

- P** Steel
- M** Stainless Steel
- K** Cast Iron
- N** Non-ferrous
- S** Exotic Materials
- H** Hardened Steel

- USA Stocked Item
- ★ Worldwide Warehouse Item
- ▲ USA Limited Availability Item
- In stock by 1st Quarter 2017

Positive Inserts

C

D

R

S

T

V

W

Swiss Tooling

SPMT EFK		Rake Angle: 0° 	Cutting Conditions:				Coated			Cermet			Uncoated		
			Continuous Cut	Medium Cut	Interrupted Cut										
		Light Cutting Depth (Inches) vs Feed (Inches/Rev) graph													
Sumitomo Catalog #	ISO Catalog #	I.C.	T	r	ød1	T1 500Z			T2000Z			T1 200A			
SPMT321EFK	SPMT090304N-FK	.375	.125	.0156	.130	●			●			▲			
SPMT322EFK	SPMT090308N-FK			.0313		●			●			▲			

SPMT ELU		Rake Angle: 12° 	Cutting Conditions:				Coated					Cermet		Uncoated	
			Continuous Cut	Medium Cut	Interrupted Cut										
		Light Cutting Depth (Inches) vs Feed (Inches/Rev) graph													
Sumitomo Catalog #	ISO Catalog #	I.C.	T	r	ød1	AC810P									
SPMT321ELU	SPMT090304N-LU	.375	.125	.0156	.130	●									
SPMT322ELU	SPMT090308N-LU			.0313		●									

SPMR EFK		Rake Angle: 0° 	Cutting Conditions:				Coated			Cermet			Uncoated		
			Continuous Cut	Medium Cut	Interrupted Cut										
		Light Cutting Depth (Inches) vs Feed (Inches/Rev) graph													
Sumitomo Catalog #	ISO Catalog #	I.C.	T	r	ød1	T1 500Z			T2000Z			T1 500A			
SPMR321EFK	SPMR090304N-FK	.375		.0156		●			●			▲			
SPMR322EFK	SPMR090308N-FK			.0313		●			●			▲			
SPMR421EFK	SPMR120304N-FK		.125	.0156	-	●			★			▲			
SPMR422EFK	SPMR120308N-FK	.500		.0313		●			●			▲			
SPMR423EFK	SPMR120312N-FK			.0469		●			●			▲			



SP



90° Square Type



11° Relief

Without Insert Hole

- P** Steel
- M** Stainless Steel
- K** Cast Iron
- N** Non-ferrous
- S** Exotic Materials
- H** Hardened Steel

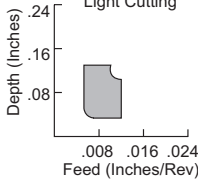
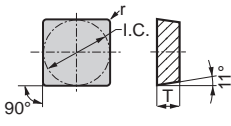
- USA Stocked Item
- ★ Worldwide Warehouse Item
- ▲ USA Limited Availability Item
- In stock by 1st Quarter 2017

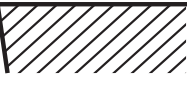
SPMR ENF		Rake Angle: 0° 	Cutting Conditions:						Coated		Cermet		Uncoated	
			Continuous Cut	Medium Cut	Interrupted Cut	●	●							
		Light Cutting  Depth (Inches) vs Feed (Inches/Rev)			AC820P		AC830P							
					Sumitomo Catalog #	ISO Catalog #	I.C.	T	r	ød1				
SPMR321ENF		SPMR090304N-SF	.375		.0156		●	●						
SPMR322ENF		SPMR090308N-SF			.0313		●	●						
SPMR421ENF		SPMR120304N-SF		.125	.0156		●	●						
SPMR422ENF		SPMR120308N-SF	.500		.0313		●	●						
SPMR423ENF		SPMR120312N-SF			.0469		●	●						

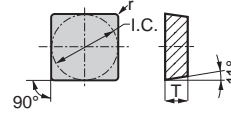
SPMN -		No Breaker 	Cutting Conditions:						Coated		Cermet		Uncoated													
			Continuous Cut	Medium Cut	Interrupted Cut	●	●	●	●	●	●	●	●													
					AC8025P		AC820P		AC700G		AC410K		AC415K		AC420K		T1500A		T1200A		G10E		A30		ST20E	
					Sumitomo Catalog #	ISO Catalog #	I.C.	T	r	ød1																
SPMN321		SPMN090304	.375		.0156		●	●																		
SPMN322		SPMN090308			.0313		●	●	★																	
SPMN421		SPMN120304		.125	.0156		●	●	★																	
SPMN422		SPMN120308	.500		.0313		●	●	★																	
SPMN423		SPMN120312			.0469		●	●	★																	
SPMN532		SPMN150408	.625		.0313		●	●	★																	
SPMN533		SPMN150412			.0469		●	●	★																	
SPMN631		SPMN190404		.1875	.0156		●	●	★																	
SPMN632		SPMN190408			.0313		●	●	★																	
SPMN633		SPMN190412	.750		.0469		●	●	★																	
SPMN634		SPMN190416			.0625		●	●	★																	



Positive Inserts

C

D

R

S

T

V

W

Swiss Tooling

TRIANGULAR TYPE

POSITIVE INSERT

Indexable Inserts for Turning

TB

Triangular Type

5° Relief

With Insert Hole

- P** Steel
- M** Stainless Steel
- K** Cast Iron
- N** Non-ferrous
- S** Exotic Materials
- H** Hardened Steel

- USA Stocked Item
- ★ Worldwide Warehouse Item
- ▲ USA Limited Availability Item
- In stock by 1st Quarter 2017

Positive Inserts

C

D

R



S



T

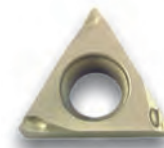

V

W

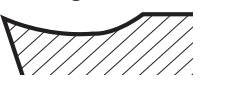
Swiss Tooling

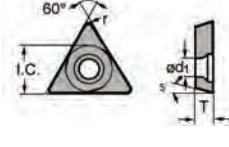
TBGT FW		Rake Angle: 20° 	Cutting Conditions:			Coated		Cermet		Uncoated					
			Continuous Cut	Medium Cut	Interrupted Cut										
		Light Cutting Depth (Inches) vs Feed (IPR) graph Feed (IPR) scale: .008, .016, .024					T1500Z		T2000Z						
							T1500A		T1200A						
Sumitomo Catalog #	ISO Catalog #	I.C.	T	r	ød1										
TBGT520.5RFX	TBGT060102R-FW	.156	.0625	.0078	.090										
TBGT520.5LFX	TBGT060102L-FW			.0078											
TBGT521RFX	TBGT060104R-FW			.0156											
TBGT521LFX	TBGT060104L-FW			.0156											

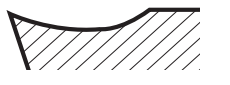
TBGT FX		Rake Angle: 15° 	Cutting Conditions:			Coated		Cermet	Uncoated	
			Continuous Cut	Medium Cut	Interrupted Cut					
		Finishing Depth (Inches) vs Feed (IPR) graph Feed (IPR) scale: .008, .016, .024					AC8025P			
							AC820P			
Sumitomo Catalog #	ISO Catalog #	I.C.	T	r	ød1					
TBGT520.5RFX	TBGT060102R-FX	.156	.0625	.0078	.090					
TBGT520.5LFX	TBGT060102L-FX			.0078						
TBGT521RFX	TBGT060104R-FX			.0156						
TBGT521LFX	TBGT060104L-FX			.0156						

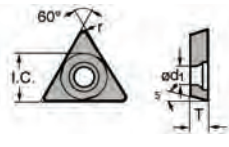
TBGT FY		Rake Angle: 15° 	Cutting Conditions:			Coated		Cermet		Uncoated					
			Continuous Cut	Medium Cut	Interrupted Cut										
		Depth of Cut (Inches) vs Feed (IPR) graph Feed (IPR) scale: .008, .016, .024					AC530U		ACZ310						
							T1500A		T1200A						
Sumitomo Catalog #	ISO Catalog #	I.C.	T	r	ød1										
TBGT520RFY	TBGT060101R-FY	.156	.0625	.0039	.090										
TBGT520LFY	TBGT060101L-FY			.0039											
TBGT520.5RFY	TBGT060102R-FY			.0078											
TBGT520.5LFY	TBGT060102L-FY			.0078											
TBGT521RFY	TBGT060104R-FY			.0156											
TBGT521LFY	TBGT060104L-FY			.0156											



TB	Triangular Type	TC	Triangular Type
	5° Relief		7° Relief
	With Insert Hole		With Insert Hole

- USA Stocked Item
- ★ Worldwide Warehouse Item
- ▲ USA Limited Availability Item
- In stock by 1st Quarter 2017

TBGT		Rake Angle: 10°		Cutting Conditions:		Coated				Cermet				Uncoated					
W																			
Sumitomo Catalog #	ISO Catalog #	I.C.	T	r	ød1	AC8025P	AC820P	AC530U	ACZ310	T1500Z	T2000Z	T3000Z	T1500A	T1200A	G10E				
TBGT520.5R	TBGT060102R-W			.0078		●	●	●	○	●	●	●	●	●					
TBGT520.5L	TBGT060102L-W			.0078		●	●	●	○	●	●	●	●	●					
TBGT521R	TBGT060104R-W	.156	.0625	.0156	.090	●	●	★	▲	●	●	●	●	▲	●				
TBGT521L	TBGT060104L-W			.0156		●	●	★	▲	●	●	●	●	▲					

TCGT		Rake Angle: 15°		Cutting Conditions:		Coated				Cermet				Uncoated					
FX																			
Sumitomo Catalog #	ISO Catalog #	I.C.	T	r	ød1	AC530U	ACZ310												
TCGT1.81.50RFX	TCGT090201R-FX			.0039		★													
TCGT1.81.50.5RFX	TCGT090202R-FX	.219		.0078	.098	★	▲												
TCGT1.81.50.5LFX	TCGT090202L-FX			.0078		★													
TCGT21.50RFX	TCGT110201R-FX		.094	.0039		★													
TCGT21.50LFX	TCGT110201L-FX	.250		.0039	.110	★	▲												
TCGT21.50.5RFX	TCGT110202R-FX			.0078		★	▲												

TCGT		Rake Angle: 15°		Cutting Conditions:		Coated				Cermet				Uncoated					
FY																			
Sumitomo Catalog #	ISO Catalog #	I.C.	T	r	ød1	AC530U	ACZ310												
TCGT1.81.50LFY	TCGT090201L-FY			.0039		★													
TCGT1.81.50.5LFY	TCGT090202L-FY	.219		.0078	.098	★	▲												
TCGT21.50RFY	TCGT110201R-FY		.094	.0039		★													
TCGT21.50LFY	TCGT110201L-FY			.0039		★													
TCGT21.50.5RFY	TCGT110202R-FY	.250		.0078	.110	★	▲												
TCGT21.50.5LFY	TCGT110202L-FY			.0078		★	▲												



Positive Inserts



Swiss Tooling

TRIANGULAR TYPE

POSITIVE INSERT

Indexable Inserts for Turning

TC

Triangular Type

7° Relief

With Insert Hole

- P** Steel
- M** Stainless Steel
- K** Cast Iron
- N** Non-ferrous
- S** Exotic Materials
- H** Hardened Steel

- USA Stocked Item
- ★ Worldwide Warehouse Item
- ▲ USA Limited Availability Item
- In stock by 1st Quarter 2017

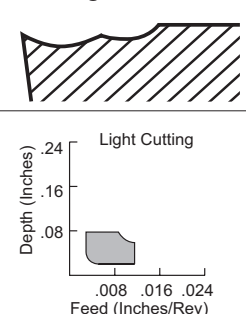
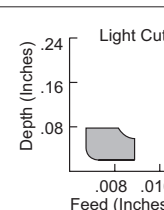
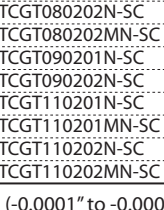
TCGT EFM		Rake Angle: 6°		Cutting Conditions:		Coated		Cermet		Uncoated			
						Continuous Cut	<input type="checkbox"/>	<input type="checkbox"/>	<input checked="" type="checkbox"/>	<input checked="" type="checkbox"/>	<input checked="" type="checkbox"/>	<input checked="" type="checkbox"/>	
						Medium Cut	<input checked="" type="checkbox"/>	<input checked="" type="checkbox"/>	<input checked="" type="checkbox"/>	<input checked="" type="checkbox"/>	<input checked="" type="checkbox"/>	<input checked="" type="checkbox"/>	
						Interrupted Cut	<input checked="" type="checkbox"/>	<input checked="" type="checkbox"/>	<input checked="" type="checkbox"/>	<input checked="" type="checkbox"/>	<input checked="" type="checkbox"/>	<input checked="" type="checkbox"/>	
Sumitomo Catalog #		ISO Catalog #		I.C.	T	r	ød1	AC530U	ACZ310	T1500Z	T2000Z	T1500A	T1200A
TCGT630EFM	TCGT080201N-SC					.0039		★					
TCGT630MEFM	TCGT080201MN-SC			.1875		.0039						★	
TCGT630.5EFM	TCGT080202N-SC					.0078		●					●
TCGT630.5MEFM	TCGT080202MN-SC					.0078						★	
TCGT1.81.50EFM	TCGT090201N-SC			.219	.094	.0039	.098		▲			★	▲
TCGT1.81.50.5EFM	TCGT090202N-SC					.0078		●	▲			★	▲
TCGT21.50EFM	TCGT110201N-SC					.0039		●	▲			●	▲
TCGT21.50MEFM	TCGT110201MN-SC					.0039						★	
TCGT21.50.5EFM	TCGT110202N-SC			.250		.0078	.110	●	▲			●	▲
TCGT21.50.5MEFM	TCGT110202MN-SC					.0078						●	▲

M = Negative nose radius tolerance (-0.0001" to -0.0004")

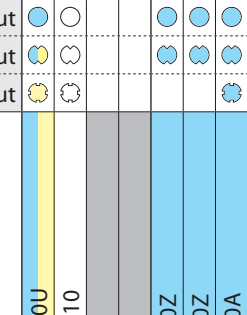
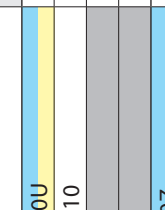
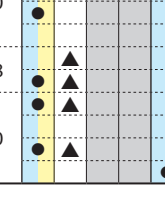
TCGT MESI		Rake Angle: 15°		Cutting Conditions:		Coated		Cermet		Uncoated		
						Continuous Cut	<input type="checkbox"/>	<input type="checkbox"/>	<input checked="" type="checkbox"/>	<input type="checkbox"/>	<input type="checkbox"/>	<input type="checkbox"/>
						Medium Cut	<input type="checkbox"/>	<input type="checkbox"/>	<input checked="" type="checkbox"/>	<input type="checkbox"/>	<input type="checkbox"/>	<input type="checkbox"/>
						Interrupted Cut	<input type="checkbox"/>	<input type="checkbox"/>	<input checked="" type="checkbox"/>	<input type="checkbox"/>	<input type="checkbox"/>	<input type="checkbox"/>
Sumitomo Catalog #		ISO Catalog #		I.C.	T	r	ød1	T1500A				
TCGT21.51MESI	TCGT110204MN-SI			.250	.094	.0156	.110	●				

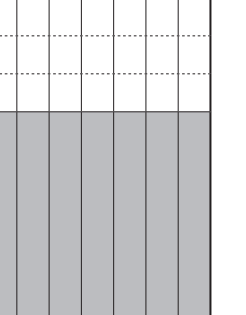
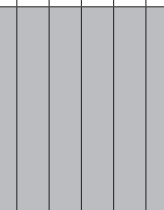
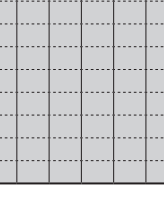
TCMT EFB		Rake Angle: 20°		Cutting Conditions:		Coated		Cermet		Uncoated		
						Continuous Cut	<input type="checkbox"/>	<input type="checkbox"/>	<input checked="" type="checkbox"/>	<input checked="" type="checkbox"/>	<input type="checkbox"/>	<input type="checkbox"/>
						Medium Cut	<input checked="" type="checkbox"/>	<input checked="" type="checkbox"/>	<input checked="" type="checkbox"/>	<input checked="" type="checkbox"/>	<input type="checkbox"/>	<input type="checkbox"/>
						Interrupted Cut	<input checked="" type="checkbox"/>	<input checked="" type="checkbox"/>	<input checked="" type="checkbox"/>	<input checked="" type="checkbox"/>	<input type="checkbox"/>	<input type="checkbox"/>
Sumitomo Catalog #		ISO Catalog #		I.C.	T	r	ød1	T1500Z	T1500A			
TCMT21.51EFB	TCMT110204N-FB			.250	.094	.0156	.110	●	●			
TCMT21.52EFB	TCMT110208N-FB					.0313		●	●			



TC



Triangular Type



7° Relief

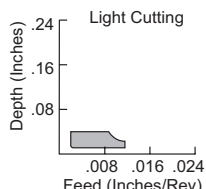

With Insert Hole

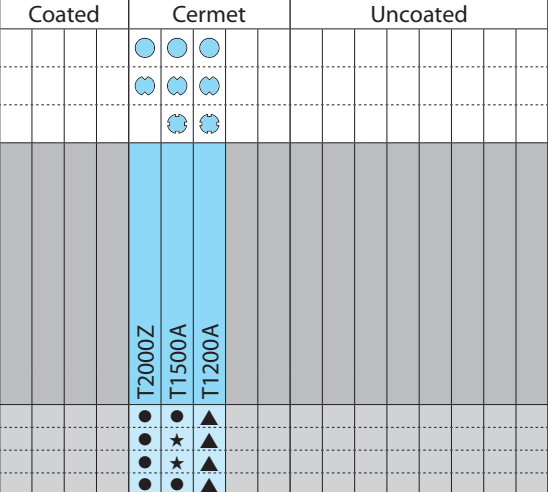
- P** Steel
- M** Stainless Steel
- K** Cast Iron
- N** Non-ferrous
- S** Exotic Materials
- H** Hardened Steel

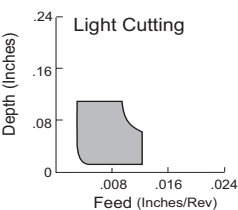
- USA Stocked Item
- ★ Worldwide Warehouse Item
- ▲ USA Limited Availability Item
- In stock by 1st Quarter 2017

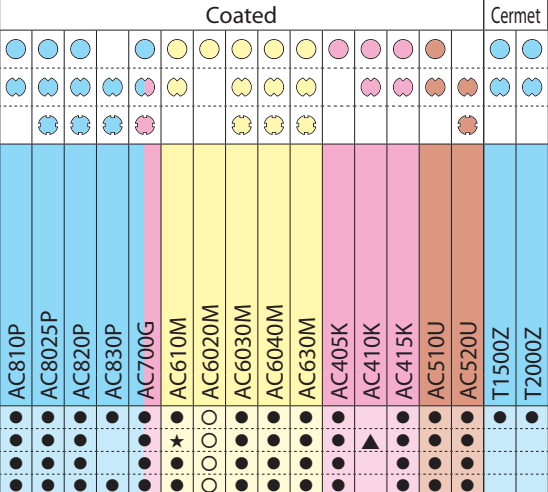
TCMT EFP		Rake Angle: 10°	Cutting Conditions:				Coated			Cermets			Uncoated				
			Continuous Cut	Medium Cut	Interrupted Cut												
																	
Sumitomo Catalog #	ISO Catalog #	I.C.	T	r	ød1												
TCMT21.51EFP	TCMT110204N-FP	.250	.094	.0156	.110												
TCMT21.52EFP	TCMT110208N-FP			.0313													
TCMT32.51EFP	TCMT16T304N-FP	.375	.156	.0156	.1693												
TCMT32.52EFP	TCMT16T308N-FP			.0313													

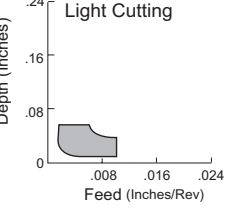
TCMT ESU		Rake Angle: 8°	Cutting Conditions:				Coated												Cermets		
			Continuous Cut	Medium Cut	Interrupted Cut																
																					
Sumitomo Catalog #	ISO Catalog #	I.C.	T	r	ød1																
TCMT21.51ESU	TCMT110204N-SU	.250	.094	.0156	.110																
TCMT21.52ESU	TCMT110208N-SU			.0313																	
TCMT32.51ESU	TCMT16T304N-SU	.375	.156	.0156	.1693																
TCMT32.52ESU	TCMT16T308N-SU			.0313																	

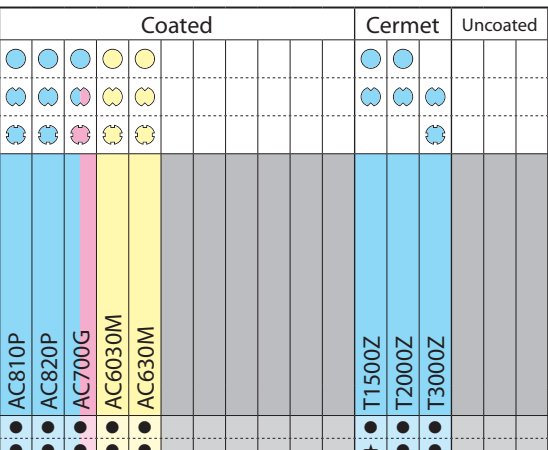
TCMT ELU		Rake Angle: 15°	Cutting Conditions:				Coated						Cermets			Uncoated	
			Continuous Cut	Medium Cut	Interrupted Cut												
																	
Sumitomo Catalog #	ISO Catalog #	I.C.	T	r	ød1												
TCMT21.51ELU	TCMT110204N-LU	.250	.094	.0156	.110												
TCMT21.52ELU	TCMT110208N-LU			.0313													



Positive Inserts

C

D

R

S

T

V

W

Swiss Tooling

TRIANGULAR TYPE

POSITIVE INSERT

Indexable Inserts for Turning

TC	Triangular Type
	7° Relief
	With Insert Hole

- P** Steel
- M** Stainless Steel
- K** Cast Iron
- N** Non-ferrous
- S** Exotic Materials
- H** Hardened Steel

- USA Stocked Item
- ★ Worldwide Warehouse Item
- ▲ USA Limited Availability Item
- In stock by 1st Quarter 2017

TCMT	Rake Angle: 15°	Cutting Conditions:						Coated		Cermet		Uncoated	
		Continuous Cut	Medium Cut	Interrupted Cut	●	○							
ELB													
Sumitomo Catalog #	ISO Catalog #	I.C.	T	r	ød1	AC8025P	AC6020M						
TCMT21.51ELB	TCMT110204N-LB	.250	.094	.0156	.110	●	○						
TCMT21.52ELB	TCMT110208N-LB					●	○						

TCMT	Rake Angle: 8°	Cutting Conditions:						Coated		Cermet		Uncoated	
		Continuous Cut	Medium Cut	Interrupted Cut	●	○							
ENK													
Sumitomo Catalog #	ISO Catalog #	I.C.	T	r	ød1	AC810P	AC8025P	AC820P	AC830P	AC700G			
TCMT21.51ENK	TCMT110204N-SK	.250	.094	.0156	.110	●	●	●	●	●			
TCMT21.52ENK	TCMT110208N-SK					●	●	●	●	●			
TCMT32.51ENK	TCMT16T304N-SK			.0156		●	●	●	●	●			
TCMT32.52ENK	TCMT16T308N-SK	.375	.156	.0313	.1693	●	●	●	●	●			
TCMT32.53ENK	TCMT16T312N-SK			.0469		●	●	●	●	●			

TCMA	No Breaker	Cutting Conditions:						Coated		Cermet		Uncoated	
		Continuous Cut	Medium Cut	Interrupted Cut	●	○							
-													
Sumitomo Catalog #	ISO Catalog #	I.C.	T	r	ød1	AC700G	AC405K	AC415K	AC420K				
TCMA21.51	TCMW 110204	.250	.094	.0156	.110	●	●	●	●				
TCMA21.52	TCMW 110208			.0313		●	●	●	●				
TCMA32.51	TCMW 16T304			.0156		●	●	●	★				
TCMA32.52	TCMW 16T308	.375	.156	.0313	.1693	●	●	●	●				
TCMA32.53	TCMW 16T312			.0469		●	●	●	●				



TP

Triangular Type

11° Relief

With Insert Hole

- P** Steel
- M** Stainless Steel
- K** Cast Iron
- N** Non-ferrous
- S** Exotic Materials
- H** Hardened Steel

- USA Stocked Item
- ★ Worldwide Warehouse Item
- ▲ USA Limited Availability Item
- In stock by 1st Quarter 2017

TPGT FW		Rake Angle: 20° 	Cutting Conditions:						Coated				Cermet				Uncoated									
			Continuous Cut						Medium Cut						Interrupted Cut											
		Light Cutting Depth (Inches) .24 .16 .08 .008 .016 .024 Feed (IPR)																								
Sumitomo Catalog #	ISO Catalog #	I.C.	T	r	ød1						T1500Z				T2000Z				T1500A				T1200A			
TPGT630.5RFX	TPGT080202R-FW	.1875	.094	.0078	.090						★				★				★							
TPGT630.5LFX	TPGT080202L-FW																									
TPGT631RFX	TPGT080204R-FW	.1875	.094	.0156	.090						●				●				●							
TPGT631LFX	TPGT080204L-FW																									
TPGT21.50.5RFX	TPGT110202R-FW	.250	.110	.0078	.110						★				★				★							
TPGT21.50.5LFX	TPGT110202L-FW																									
TPGT21.51RFX	TPGT110204R-FW	.250	.110	.0156	.110						●				●				●							
TPGT21.51LFX	TPGT110204L-FW																									

TPGT FX		Rake Angle: 15° 	Cutting Conditions:						Coated				Cermet				Uncoated									
			Continuous Cut						Medium Cut						Interrupted Cut											
		Finishing Depth (Inches) .24 .16 .08 .008 .016 .024 Feed (IPR)																								
Sumitomo Catalog #	ISO Catalog #	I.C.	T	r	ød1		AC530U				AC510U				ACZ310				T1500A				T1200A			
TPGT630.5RFX	TPGT080202R-FX	.1875	.094	.0078	.090		★				★				★				★							
TPGT630.5LFX	TPGT080202L-FX																									
TPGT631RFX	TPGT080204R-FX	.1875	.094	.0156	.090		●				●				●				●							
TPGT631LFX	TPGT080204L-FX																									
TPGT1.81.51LFX	TPGT090204L-FX	.219	.094	.0156	.102																					
TPGT21.50.5RFX	TPGT110202R-FX																									
TPGT21.50.5LFX	TPGT110202L-FX	.250	.110	.0078	.110																					
TPGT21.51RFX	TPGT110204R-FX																									
TPGT21.51LFX	TPGT110204L-FX	.250	.110	.0156	.110																					
TPGT21.52LFX	TPGT110208L-FX																									
TPGT220.5RFX	TPGT110302R-FX	.125	.130	.0078	.130		★				★				★				★							
TPGT220.5LFX	TPGT110302L-FX																									
TPGT221RFX	TPGT110304R-FX	.125	.130	.0156	.130		●				●				●				●							
TPGT221LFX	TPGT110304L-FX																									

- Positive Inserts
- C
- D
- R
- S
- T
- V
- W
- Swiss Tooling



TRIANGULAR TYPE

POSITIVE INSERT

Indexable Inserts for Turning

TP

Triangular Type



11° Relief

With Insert Hole

- P** Steel
- M** Stainless Steel
- K** Cast Iron
- N** Non-ferrous
- S** Exotic Materials
- H** Hardened Steel

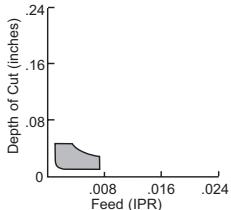
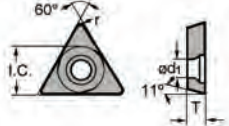
- USA Stocked Item
- ★ Worldwide Warehouse Item
- ▲ USA Limited Availability Item
- In stock by 1st Quarter 2017

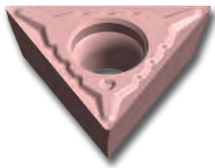
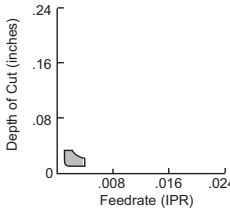
TPGT FY		Rake Angle: 15°	Cutting Conditions:		Coated		Cermet					Uncoated									
			Continuous Cut	Medium Cut	Interrupted Cut	●	○	●	○	●	○	●	○	●	○	●	○				
  				AC530U	ACZ310																
						T1500Z	T2000Z	T3000Z	T1500A	T1200A											
Sumitomo Catalog #	ISO Catalog #	I.C.	T	r	ød1																
TPGT630RFY	TPGT080201R-FY	.1875		.0039	.090	●	▲														
TPGT630LFY	TPGT080201L-FY					●	▲														
TPGT630.5RFY	TPGT080202R-FY					★	▲														
TPGT630.5LFY	TPGT080202L-FY					★	▲														
TPGT631RFY	TPGT080204R-FY	.094		.0156		●	▲														
TPGT631LFY	TPGT080204L-FY					★	▲														
TPGT21.50.5RFY	TPGT110202R-FY	.250		.0078	.110	●	▲														
TPGT21.50.5LFY	TPGT110202L-FY					●	▲														
TPGT21.51RFY	TPGT110204R-FY					★	▲														
TPGT21.51LFY	TPGT110204L-FY					★	▲														
TPGT21.52LFY	TPGT110208L-FY	.125		.0313	.130	●	▲														
TPGT220RFY	TPGT110301R-FY					★	▲														
TPGT220LFY	TPGT110301L-FY					★	▲														
TPGT220.5RFY	TPGT110302R-FY					★	▲														
TPGT220.5LFY	TPGT110302L-FY	.125		.0078	.130	●	▲														
TPGT221RFY	TPGT110304R-FY					★	▲														
TPGT221LFY	TPGT110304L-FY					★	▲														
TPGT222RFY	TPGT110308R-FY					★	▲														
TPGT222LFY	TPGT110308L-FY			.0313		●	▲														
				.0313		●	▲														

TPGT EFC		Rake Angle: 15°	Cutting Conditions:		Coated		Cermet					Uncoated									
			Continuous Cut	Medium Cut	Interrupted Cut	●	○	●	○	●	○	●	○	●	○	●	○				
  				AC530U																	
						T1500A															
Sumitomo Catalog #	ISO Catalog #	I.C.	T	r	ød1																
TPGT220.5EFC	TPGT110302N-FC	.250	.125	.0078	.130	●	○														
TPGT220.5MEFC	TPGT110302MN-FC					●	○														
TPGT221EFC	TPGT110304N-FC					●	○														
TPGT221MEFC	TPGT110304MN-FC					●	○														

M = Negative nose radius tolerance (-0.0001" to -0.0004")



TP

Triangular Type

11° Relief

With Insert Hole

- P** Steel
- M** Stainless Steel
- K** Cast Iron
- N** Non-ferrous
- S** Exotic Materials
- H** Hardened Steel

- USA Stocked Item
- ★ Worldwide Warehouse Item
- ▲ USA Limited Availability Item
- In stock by 1st Quarter 2017

TPGT W		Rake Angle: 10°		Cutting Conditions:		Coated			Cermet			Uncoated		
				Continuous Cut	Medium Cut	Interrupted Cut	●	○	○	●	○	○	●	○
		<p>Light Cutting</p>												
Sumitomo Catalog #	ISO Catalog #	I.C.	T	r	ød1									
TPGT630.5R	TPGT080202R-W	.1875	.094	.0078	.090	★	●	○	●	○	○			
TPGT630.5L	TPGT080202L-W					★	●	○	●	○	○			
TPGT631R	TPGT080204R-W					★	●	○	●	○	○			
TPGT631L	TPGT080204L-W					★	●	○	●	○	○			

TPMT EFB		Rake Angle: 20°		Cutting Conditions:		Coated			Cermet			Uncoated		
				Continuous Cut	Medium Cut	Interrupted Cut	●	○	○	●	○	○	●	○
		<p>Finishing</p>												
Sumitomo Catalog #	ISO Catalog #	I.C.	T	r	ød1									
TPMT222EFB	TPMT110308N-FB	.250	.125	.0313	.110				●	○	○			

- Positive Inserts
- C
- D
- R
- S
- T
- V
- W
- Swiss Tooling



TRIANGULAR TYPE

POSITIVE INSERT

Indexable Inserts for Turning

TP

Triangular Type

11° Relief

With Insert Hole

- P** Steel
- M** Stainless Steel
- K** Cast Iron
- N** Non-ferrous
- S** Exotic Materials
- H** Hardened Steel

- USA Stocked Item
- ★ Worldwide Warehouse Item
- ▲ USA Limited Availability Item
- In stock by 1st Quarter 2017

TPMT		Rake Angle: 0°	Cutting Conditions:						Coated		Cermet		Uncoated					
EFK			Continuous Cut								●	●	●	●				
		Medium Cut								●	●	●	●					
		Interrupted Cut										●	●					
		<p>Light Cutting</p> <p>Depth (Inches)</p> <p>Feed (Inches/Rev)</p>								T1500Z	T2000Z	T1500A	T1200A					
Sumitomo Catalog #	ISO Catalog #	I.C.	T	r	ød1													
TPMT221EFK	TPMT110304N-FK	.250	.125	.0156	.110					●	●	▲						
TPMT222EFK	TPMT110308N-FK			.0313						●	●	▲						
TPMT331EFK	TPMT160404N-FK	.375	.1875	.0156	.1693					●	●	▲						
TPMT332EFK	TPMT160408N-FK			.0313						●	●	▲						

TPMT		Rake Angle: 12°	Cutting Conditions:						Coated				Cermet		Uncoated								
ELU			Continuous Cut						●	●	●	●	●	○	●	●							
		Medium Cut						●	●	●	●	●	●	●	●	●	●						
		Interrupted Cut						●	●	●	●	●	●	●	●	●	●						
		<p>Light Cutting</p> <p>Depth (Inches)</p> <p>Feed (Inches/Rev)</p>								AC810P	AC8025P	AC820P	AC700G	AC530U	ACZ310	AC6030M	AC6040M	AC630M	T1500Z	T2000Z	T3000Z		
Sumitomo Catalog #	ISO Catalog #	I.C.	T	r	ød1																		
TPMT1.81.50.5ELU	TPMT090202N-LU	.219	.094	.0078	.102					●	●	●											
TPMT1.81.51ELU	TPMT090204N-LU			.0156						●	●	●											
TPMT221ELU	TPMT110304N-LU	.250	.125	.0156	.130					●	●	●	★	▲	●	●	●	●	●				
TPMT222ELU	TPMT110308N-LU			.0313						●	●	●	★		●	●	●	●	●				

- Positive Inserts
- C
- D
- R
- S
- T
- V
- W
- Swiss Tooling



TP



Triangular Type

11° Relief

With Insert Hole

- P** Steel
- M** Stainless Steel
- K** Cast Iron
- N** Non-ferrous
- S** Exotic Materials
- H** Hardened Steel

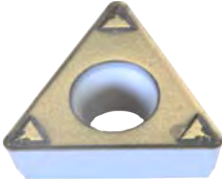
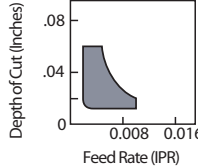
- USA Stocked Item
- ★ Worldwide Warehouse Item
- ▲ USA Limited Availability Item
- In stock by 1st Quarter 2017

TPMT ELB		Rake Angle: 15°	Cutting Conditions:						Coated				Cermet		Uncoated		
			Continuous Cut	Medium Cut	Interrupted Cut	●	○	○	○	○	○	○	○	○			
  			AC8025P	AC6020M													
Sumitomo Catalog #	ISO Catalog #	I.C.	T	r	ød1	●	○	○	○	○	○	○	○	○	○	○	○
TPMT630.5ELB	TPMT080202N-LB	.1875	.094	.0078	.090	●	○										
TPMT631ELB	TPMT080204N-LB			.0156		○	○										
TPMT1.81.50.5ELB	TPMT090202N-LB	.219	.094	.0078	.102	●	○										
TPMT1.81.51ELB	TPMT090204N-LB			.0156		●	○										
TPMT220.5ELB	TPMT110302N-LB			.0078		●	○										
TPMT221ELB	TPMT110304N-LB	.250		.0156	.130	●	○										
TPMT222ELB	TPMT110308N-LB		.125	.0313		●	○										
TPMT321ELB	TPMT160304N-LB			.0156		●	○										
TPMT322ELB	TPMT160308N-LB			.0313		●	○										
TPMT331ELB	TPMT160404N-LB	.375		.0156	.1693	●	○										
TPMT332ELB	TPMT160408N-LB		.1875	.0313		●	○										

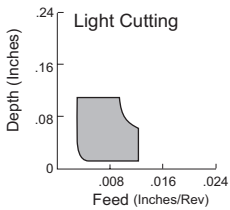
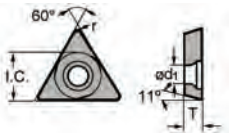
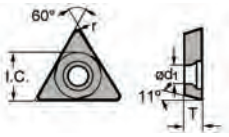
TPMT ESU		Rake Angle: 8°	Cutting Conditions:						Coated						Cermet					
			Continuous Cut	Medium Cut	Interrupted Cut	●	○	○	○	○	○	○	○	○	○	○	○	○	○	
  			AC810P	AC8025P	AC820P	AC830P	AC700G	AC530U	AC610M	AC6020M	AC6030M	AC6040M	AC630M	AC510U	AC520U	T1 500Z	T2000Z	T3000Z	T1 500A	T1 200A
Sumitomo Catalog #	ISO Catalog #	I.C.	T	r	ød1	●	○	○	○	○	○	○	○	○	○	○	○	○	○	○
TPMT630.5ESU	TPMT080202N-SU	.1875		.0078	.090	●	○													
TPMT631ESU	TPMT080204N-SU			.0156		○	○													
TPMT1.81.50.5ESU	TPMT090202N-SU	.219	.094	.0078	.102	●	○													
TPMT1.81.51ESU	TPMT090204N-SU			.0156		●	○													
TPMT21.50.5ESU	TPMT110202N-SU			.0078		●	○													
TPMT21.51ESU	TPMT110204N-SU			.0156	.107	●	○													
TPMT21.52ESU	TPMT110208N-SU			.0313		●	○													
TPMT220.5ESU	TPMT110302N-SU	.250		.0078		●	○													
TPMT221ESU	TPMT110304N-SU		.125	.0156	.130	●	○													
TPMT222ESU	TPMT110308N-SU			.0313		●	○													
TPMT32.51ESU	TPMT16T304N-SU		.156	.0156		●	○													
TPMT32.52ESU	TPMT16T308N-SU			.0313		●	○													
TPMT331ESU	TPMT160404N-SU	.375		.0156	.1693	●	○													
TPMT332ESU	TPMT160408N-SU		.1875	.0313		●	○													



Positive Inserts

C

D

R

S

T

V

W

Swiss Tooling

TRIANGULAR TYPE

POSITIVE INSERT

Indexable Inserts for Turning

TP Triangular Type
 11° Relief
 With Insert Hole

- P** Steel
- M** Stainless Steel
- K** Cast Iron
- N** Non-ferrous
- S** Exotic Materials
- H** Hardened Steel

- USA Stocked Item
- ★ Worldwide Warehouse Item
- ▲ USA Limited Availability Item
- In stock by 1st Quarter 2017

TPMT ENF	Rake Angle: 0° 	Cutting Conditions:		Coated					Cermets		Uncoated		
		Continuous Cut	Medium Cut	Interrupted Cut	●	●	●	●	●	●	●	●	
	Light Cutting Depth (Inches) vs Feed (Inches/Rev) graph Feed: .008, .016, .024												
Sumitomo Catalog #	ISO Catalog #	I.C.	T	r	ød1	AC8025P	AC820P	AC830P	AC700G	AC510U			
TPMT221ENF	TPMT110304N-SF	.250	.125	.0156	.130	●	●	●	●	●			
TPMT222ENF	TPMT110308N-SF			.0313		●	●	●	●	●			
TPMT331ENF	TPMT160404N-SF	.375	.1875	.0156	.1693	●	●	●	●	●			
TPMT332ENF	TPMT160408N-SF			.0313		●	●	●	●	●			

TPMT EMU	Rake Angle: 0° 	Cutting Conditions:		Coated							Cermets		Uncoated	
		Continuous Cut	Medium Cut	Interrupted Cut	●	●	●	●	●	●	●	●	●	●
	Medium Cutting Depth (Inches) vs Feed (Inches/Rev) graph Feed: .008, .016, .024													
Sumitomo Catalog #	ISO Catalog #	I.C.	T	r	ød1	AC810P	AC8025P	AC820P	AC700G	AC405K	AC415K	AC420K	AC6020M	
TPMT221EMU	TPMT110304N-MU	.250	.125	.0156	.130	●	●	●	●	●	●	●	○	
TPMT222EMU	TPMT110308N-MU			.0313		●	●	●	●	●	●	●	○	
TPMT331EMU	TPMT160404N-MU	.375	.1875	.0156	.1693	●	●	●	●	●	●	●	○	
TPMT332EMU	TPMT160408N-MU			.0313		●	●	●	●	●	●	●	○	



Positive Inserts
C
D
R
S
T
V
W
Swiss Tooling

TP

Triangular Type

11° Relief

With Insert Hole

- P** Steel
- M** Stainless Steel
- K** Cast Iron
- N** Non-ferrous
- S** Exotic Materials
- H** Hardened Steel

- USA Stocked Item
- ★ Worldwide Warehouse Item
- ▲ USA Limited Availability Item
- In stock by 1st Quarter 2017

TPGG SD			Cutting Conditions:						Coated			Cermet			Uncoated										
			Continuous Cut	Medium Cut	Interrupted Cut	●	●	○	●	●	○	●	●	○	●	●	○								
							AC530U	AC510U	ACZ310				T1500Z	T2000Z	T3000Z	T1500A	T1200A	G10E							
Sumitomo Catalog #	ISO Catalog #	I.C.	T	r	ød1																				
TPGG220.5R	TPGT110302R-SD	.250	.125	.0078	.130	★							★	●	●	●	▲								
TPGG220.5L	TPGT110302L-SD									★	●						★	●	●	●	▲				
TPGG221R	TPGT110304R-SD							.0156		★	●						★	●	●	●	▲				
TPGG221RW	TPGX110304R-SDW							.0156										●	●	●	▲				
TPGG221L	TPGT110304L-SD							.0156		★	●	▲					●	●	●	●	▲				●
TPGG221LW	TPGX110304L-SDW							.0156										●	●	●	▲				
TPGG222R	TPGT110308R-SD							.0313		★		▲								●	▲				
TPGG222RW	TPGX110308R-SDW							.0313										●	●	●	▲				
TPGG222L	TPGT110308L-SD							.0313									★	●	●	●	▲				
TPGG222LW	TPGX110308L-SDW							.0313										●	●	●	▲				
TPGG321R	TPGT160304R-SD	.375	.1875	.0156	.1693												▲								
TPGG321L	TPGT160304L-SD							.0156													▲				
TPGG322R	TPGT160308R-SD							.0313													▲				
TPGG322L	TPGT160308L-SD							.0313													▲				
TPGG330R	TPGT160401R-SD							.0039														●			
TPGG330L	TPGT160401L-SD							.0039														●			
TPGG330.5R	TPGT160402R-SD							.0078														●			
TPGG330.5L	TPGT160402L-SD							.0078														●			
TPGG331R	TPGT160404R-SD							.0156														●			
TPGG331L	TPGT160404L-SD							.0156														●			
TPGG332R	TPGT160408R-SD			.0313														●							
TPGG332L	TPGT160408L-SD			.0313														●							

W = Wiper insert

TPEW EW			Cutting Conditions:						Coated			Cermet			Uncoated									
			Continuous Cut	Medium Cut	Interrupted Cut	●	●	○	●	●	○	●	●	○	●	●	○							
Sumitomo Catalog #	ISO Catalog #	I.C.	T	r	ød1																			
TPEW1.81.51	TPEW090204	.219	.094	.0156	.102																			
TPEW21.51	TPEW110204	.250																						
TPEW21.52	TPEW110208							.0313	.110															



Positive Inserts



SWISS Tooling

TRIANGULAR TYPE



POSITIVE INSERT

Indexable Inserts for Turning

TP Triangular Type
 11° Relief
 With Insert Hole

- P** Steel
- M** Stainless Steel
- K** Cast Iron
- N** Non-ferrous
- S** Exotic Materials
- H** Hardened Steel

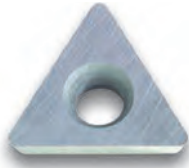
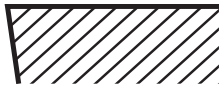
- USA Stocked Item
- ★ Worldwide Warehouse Item
- ▲ USA Limited Availability Item
- In stock by 1st Quarter 2017

TPGA	No Breaker	Cutting Conditions:						Coated			Cermet			Uncoated					
		Continuous Cut	Medium Cut	Interrupted Cut															
																			
Sumitomo Catalog #	ISO Catalog #	I.C.	T	r	ød ₁														
TPGA220.5	TPGW110302			.0078															
TPGA221	TPGW110304	.250	.125	.0156	.130														
TPGA222	TPGW110308			.0313															
TPGA331	TPGW160404	.375	.1875	.0156	.1693														

- Positive Inserts
- C
- D
- R
- S
- T
- V
- W
- Swiss Tooling



TP

Triangular Type

11° Relief

Without Insert Hole

- P** Steel
- M** Stainless Steel
- K** Cast Iron
- N** Non-ferrous
- S** Exotic Materials
- H** Hardened Steel

- USA Stocked Item
- ★ Worldwide Warehouse Item
- ▲ USA Limited Availability Item
- In stock by 1st Quarter 2017

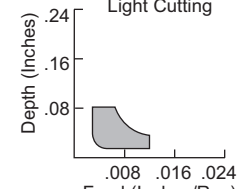
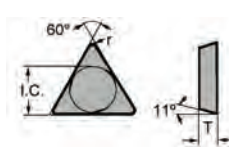
TPMR EFK		Rake Angle: 0°	Cutting Conditions:						Coated				Cermet				Uncoated											
			Continuous Cut	Medium Cut	Interrupted Cut																							
													T1500Z				T2000Z				T1500A				T1200A			
Sumitomo Catalog #	ISO Catalog #	I.C.	T	r	ød1																							
TPMR1.81.50.5EFK	TPMR090202N-FK	.219	.094	.0078																								
TPMR1.81.51EFK	TPMR090204N-FK			.0156																								
TPMR1.81.52EFK	TPMR090208N-FK			.0313																								
TPMR220.5EFK	TPMR110302N-FK	.250	.125	.0078																								
TPMR221EFK	TPMR110304N-FK			.0156																								
TPMR222EFK	TPMR110308N-FK			.0313																								
TPMR321EFK	TPMR160304N-FK	.375		.0156																								
TPMR322EFK	TPMR160308N-FK			.0313																								
TPMR323EFK	TPMR160312N-FK			.0469																								

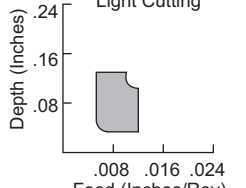
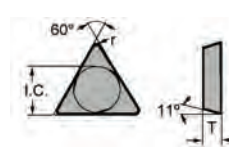
TPMR ENF		Rake Angle: 0°	Cutting Conditions:						Coated				Cermet				Uncoated											
			Continuous Cut	Medium Cut	Interrupted Cut																							
													AC8025P				AC820P				AC830P				AC700G			
Sumitomo Catalog #	ISO Catalog #	I.C.	T	r	ød1																							
TPMR221ENF	TPMR110304N-SF	.250	.125	.0156																								
TPMR222ENF	TPMR110308N-SF			.0313																								
TPMR321ENF	TPMR160304N-SF			.0156																								
TPMR322ENF	TPMR160308N-SF	.375		.0313																								
TPMR323ENF	TPMR160312N-SF			.0469																								
TPMR432ENF	TPMR220408N-SF			.0313																								
TPMR433ENF	TPMR220412N-SF	.500	.1875	.0313																								

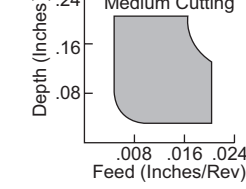
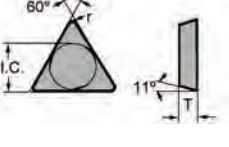
TPMR EUJ		Rake Angle: 0°	Cutting Conditions:						Coated				Cermet				Uncoated							
			Continuous Cut	Medium Cut	Interrupted Cut																			
													AC8025P											
Sumitomo Catalog #	ISO Catalog #	I.C.	T	r	ød1																			
TPMR322EUJ	TPMR160308N-UJ	.375	.125	.0313	-																			



Positive Inserts



Swiss Tooling

TRIANGULAR TYPE

POSITIVE INSERT

Indexable Inserts for Turning

TP

Triangular Type



11° Relief

Without Insert Hole

- P Steel
- M Stainless Steel
- K Cast Iron
- N Non-ferrous
- S Exotic Materials
- H Hardened Steel

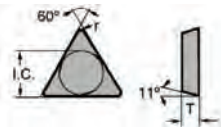
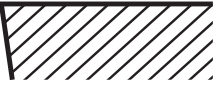
- USA Stocked Item
- ★ Worldwide Warehouse Item
- ▲ USA Limited Availability Item
- In stock by 1st Quarter 2017

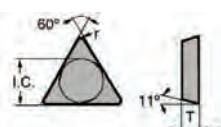
TPG		No Breaker	Cutting Conditions:						Coated			Cermet				Uncoated			
			Continuous Cut	Medium Cut	Interrupted Cut	●	●	●	●	●	●	●	●	●	●	●	●	●	●
 			I.C.	T	r	ød1	AC8025P	AC820P	AC510U	T1500Z	T2000Z	T1500A	T1200A	A30	G10E	H1	ST30E	EH20Z	
			Sumitomo Catalog #	ISO Catalog #															
TPG220.5	TPGN110302		.250		.0078	●	●				●	▲							
TPG221	TPGN110304				.0156	●	●												
TPG222	TPGN110308				.0313	●	●												
TPG320.5	TPGN160302			.125	.0078	●	●		●	●	●	▲							
TPG321	TPGN160304				.0156	●	●												
TPG322	TPGN160308				.0313	●	●												
TPG323	TPGN160312		.375		.0469	●	●												
TPG324	TPGN160316				.0625	●	●												
TPG332	TPGN160408				.0313	●	●												
TPG431	TPGN220404				.0156	●	●												
TPG432	TPGN220408		.500	.1875	.0313	●	●	●				▲							
TPG433	TPGN220412				.0469	●	●												
TPG434	TPGN220416				.0625	●	●												
TPG436	TPGN220424				.0938	●	●												

TPMN		No Breaker	Cutting Conditions:						Coated			Cermet		Uncoated		
			Continuous Cut	Medium Cut	Interrupted Cut	●	●	●	●	●	●	●	●	●		
 			I.C.	T	r	ød1	AC8025P	AC820P	AC700G	AC410K	AC420K	T1500A	T1200A	A30	ST20E	ST30E
			Sumitomo Catalog #	ISO Catalog #												
TPMN221	TPMN110304		.250		.0156	●	●	★	▲	●					★	
TPMN222	TPMN110308				.0313	●	●	★	▲	●					★	
TPMN321	TPMN160304			.125	.0156	●	●	★	▲	●					★	
TPMN322	TPMN160308				.0313	●	●	★	▲	●					★	
TPMN323	TPMN160312		.375		.0469	●	●	★	▲	●					★	
TPMN431	TPMN220404				.0156	●	●								★	
TPMN432	TPMN220408				.0313	●	●								★	
TPMN433	TPMN220412		.500	.1875	.0469	●	●				★	▲			●	
TPMN434	TPMN220416				.0625	●	●								★	★



TE



Triangular Type



20° Relief

Without Insert Hole

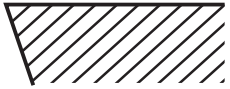
- P** Steel
- M** Stainless Steel
- K** Cast Iron
- N** Non-ferrous
- S** Exotic Materials
- H** Hardened Steel

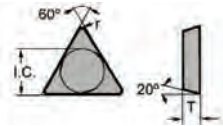
- USA Stocked Item
- ★ Worldwide Warehouse Item
- ▲ USA Limited Availability Item
- In stock by 1st Quarter 2017

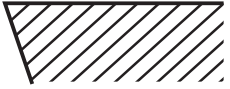
TEGE		No Breaker 	Cutting Conditions:				Coated		Cermet		Uncoated			
			Continuous Cut	Medium Cut	Interrupted Cut									
 														
		Sumitomo Catalog #		ISO Catalog #		I.C.	T	r	ød1					
TEGE21.50.5		TEGE110202		.250	.094	.0078	-							
TEGE21.51		TEGE110204				.0156								

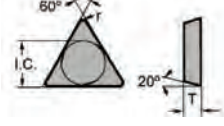
TEGN		No Breaker 	Cutting Conditions:				Coated		Cermet		Uncoated			
			Continuous Cut	Medium Cut	Interrupted Cut									
 														
		Sumitomo Catalog #		ISO Catalog #		I.C.	T	r	ød1	T1500A	T1200A			
TEGN220.5		TEGN110302		.250		.0078								
TEGN222		TEGN110308			.125	.0313								
TEGN320.5		TEGN160302				.0078								
TEGN322		TEGN160308		.375		.0313		★	▲					

Positive Inserts

C

D

R

S

T

V

W

Swiss Tooling



35° DIAMOND TYPE

POSITIVE INSERT

Indexable Inserts for Turning

VB

35° Diamond Type

5° Relief

With Insert Hole

- P** Steel
- M** Stainless Steel
- K** Cast Iron
- N** Non-ferrous
- S** Exotic Materials
- H** Hardened Steel

- USA Stocked Item
- ★ Worldwide Warehouse Item
- ▲ USA Limited Availability Item
- In stock by 1st Quarter 2017

Positive Inserts

C

D

R





S



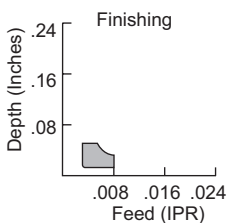

T

V

W

Swiss Tooling

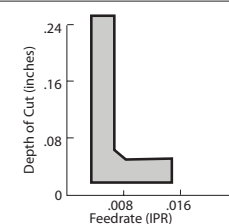
VBGT FX		Rake Angle: 15° 	Cutting Conditions:				Coated		Cermet		Uncoated	
			Continuous Cut	Medium Cut	Interrupted Cut							
  Finishing Depth (Inches): .24, .16, .08 Feed (IPR): .008, .016, .024		 I.C. 35° T r ød1		AC530U								
				Sumitomo Catalog #	ISO Catalog #	I.C.	T	r	ød1			
VBGT220.5LFX	VBGT110302L-FX	.250	.125	.0078	.110	★						

VBGT ESI		Rake Angle: 15° 	Cutting Conditions:				Coated		Cermet		Uncoated	
			Continuous Cut	Medium Cut	Interrupted Cut							
  Depth of Cut (Inches): .24, .16, .08 Feedrate (IPR): .008, .016		 I.C. 35° T r ød1		AC530U, AC6030M, AC510U, AC520U								
				Sumitomo Catalog #	ISO Catalog #	I.C.	T	r	ød1			
VBGT220MESI	VBGT110301MN-SI			.0039		●	●	●	●			
VBGT220.5MESI	VBGT110302MN-SI	.250	.125	.0078	.110	●	●	●	●			
VBGT221MESI	VBGT110304MN-SI			.0156		●	●	●	●			
VBGT222MESI	VBGT110308MN-SI			.0313		●	●	●	●			
VBGT330MESI	VBGT160401MN-SI			.0039		●	●	●	●			
VBGT330.5MESI	VBGT160402MN-SI	.375	.1875	.0078	.1732	●	●	●	●			
VBGT331MESI	VBGT160404MN-SI			.0156		●	●	●	●			
VBGT332MESI	VBGT160408MN-SI			.0313		●	●	●	●			

M = Negative nose radius tolerance (-0.0001" to -0.0004") as with similar items.



VB



35° Diamond Type



5° Relief

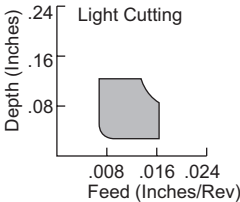

With Insert Hole

- P** Steel
- M** Stainless Steel
- K** Cast Iron
- N** Non-ferrous
- S** Exotic Materials
- H** Hardened Steel

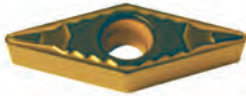
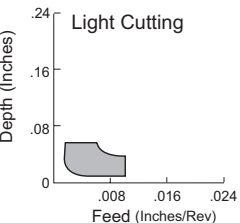
- USA Stocked Item
- ★ Worldwide Warehouse Item
- ▲ USA Limited Availability Item
- In stock by 1st Quarter 2017

VBMT ENK		Rake Angle: 8°	Cutting Conditions:						Coated			Cermets			Uncoated					
			Continuous Cut	Medium Cut	Interrupted Cut	●	●													
									AC8025P	AC820P										
									●	●										
Sumitomo Catalog #	ISO Catalog #	I.C.	T	r	ød1															
VBMT332ENK	VBMT160408N-SK	.375	.1875	.0313	.1732															

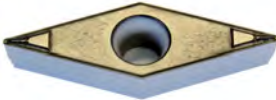
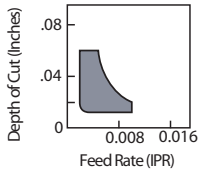
VBMT ELU		Rake Angle: 15°	Cutting Conditions:						Coated						Cermets			Uncoated											
			Continuous Cut	Medium Cut	Interrupted Cut	●	●	●	●	●	●	●	●	●	●	●	●	●	●	●	●	●	●	●	●	●	●		
									AC810P	AC8025P	AC820P	AC700G	AC530U	AC6030M	AC6040M	AC630M	ACZ310	T1500Z	T2000Z	T3000Z									
									●	●	★	●	●	●	●	●	▲	●	●	●	●	●	●	●	●	●			
Sumitomo Catalog #	ISO Catalog #	I.C.	T	r	ød1																								
VBMT221ELU	VBMT110304N-LU	.250	.125	.0156	.110																								
VBMT331ELU	VBMT160404N-LU	.375	.1875	.0156	.1732																								
VBMT332ELU	VBMT160408N-LU			.0313																									

VBMT ELB		Rake Angle: 15°	Cutting Conditions:						Coated						Cermets			Uncoated											
			Continuous Cut	Medium Cut	Interrupted Cut	●	●	●	●	●	●	●	●	●	●	●	●	●	●	●	●	●	●	●	●	●			
									AC8025P	AC6020M																			
									●	○																			
Sumitomo Catalog #	ISO Catalog #	I.C.	T	r	ød1																								
VBMT220.5ELB	VBMT110302N-LB			.0078																									
VBMT221ELB	VBMT110304N-LB	.250	.125	.0156	.110																								
VBMT222ELB	VBMT110308N-LB			.0313																									
VBMT331ELB	VBMT160404N-LB			.0156																									
VBMT332ELB	VBMT160408N-LB	.375	.1875	.0313	.1732																								
VBMT333ELB	VBMT160412N-LB			.0469																									



Positive Inserts

C

D

R

S

T

V

W

Swiss Tooling

35° DIAMOND TYPE

POSITIVE INSERT

Indexable Inserts for Turning

VB 35° Diamond Type
5° Relief
With Insert Hole

- P** Steel
 - M** Stainless Steel
 - K** Cast Iron
 - N** Non-ferrous
 - S** Exotic Materials
 - H** Hardened Steel
- USA Stocked Item
 - ★ Worldwide Warehouse Item
 - ▲ USA Limited Availability Item
 - In stock by 1st Quarter 2017

VBMT ESU	Rake Angle: 8° 	Cutting Conditions:						Coated						Cermet									
		Continuous Cut						●	●	●	●	●	●	●	●	●	●	●	●	●			
		Medium Cut						●	●	●	●	●	●	●	●	●	●	●	●	●			
								●	●	●	●	●	●	●	●	●	●	●	●	●	●	●	
Sumitomo Catalog #	ISO Catalog #	I.C.	T	r	ød1		AC810P	AC8025P	AC820P	AC830P	AC700G	AC610M	AC6030M	AC630M	AC510U	AC520U	T1500Z	T2000Z	T3000Z	T1500A	T1200A		
VBMT221ESU	VBMT110304N-SU	.250	.125	.0156	.110	●	●	●	●	●	●	●	●	●	●	●	●	●	●	●	●	▲	
VBMT222ESU	VBMT110308N-SU			.0313		●	●	●	●	●	●	●	●	●	●	●	●	●	●	●	●	●	●
VBMT331ESU	VBMT160404N-SU	.375	.1875	.0156	.1732	●	●	●	●	●	●	●	●	●	●	●	●	●	●	●	●	●	▲
VBMT332ESU	VBMT160408N-SU			.0313		●	●	●	●	●	●	●	●	●	●	●	●	●	●	●	●	●	▲

VBMA	No Breaker 	Cutting Conditions:						Coated				Cermet				Uncoated							
		Continuous Cut						●	●	●													
		Medium Cut						●	●	●	●												
								●	●	●	●												
Sumitomo Catalog #	ISO Catalog #	I.C.	T	r	ød1		AC700G	AC405K	AC415K	AC420K													
VBMA331	VBMA160404	.375	.1875	.0156	.1732	●	★	●	●	●													
VBMA332	VBMA160408			.0313		●	★	★	★	●													



Positive Inserts
C
D
R
S
T
V
W
Swiss Tooling

VC



35° Diamond Type



7° Relief

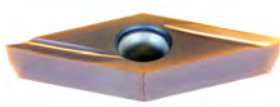
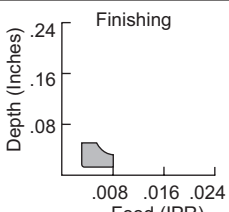

With Insert Hole

- P** Steel
- M** Stainless Steel
- K** Cast Iron
- N** Non-ferrous
- S** Exotic Materials
- H** Hardened Steel

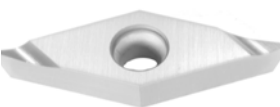
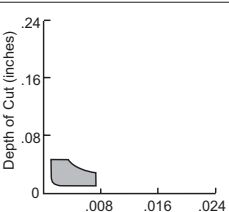
- USA Stocked Item
- ★ Worldwide Warehouse Item
- ▲ USA Limited Availability Item
- In stock by 1st Quarter 2017

VCGT FX		Rake Angle: 15°		Cutting Conditions:		Coated		Cermet		Uncoated	
  		Finishing Depth (inches) .24 .16 .08 .008 .016 .024 Feed (IPR)		Continuous Cut Medium Cut Interrupted Cut		● ○		● ●			
						● ○		● ●			
						● ○		● ●			
Sumitomo Catalog #	ISO Catalog #	I.C.	T	r	ød1	AC530U	ACZ310	T1500A	T1200A		
VCGT220RFX	VCGT110301R-FX	.250	.125	.0039	.110	★	▲	★	▲		
VCGT220LFX	VCGT110301L-FX			.0039		★	▲	★	▲		
VCGT220.5RFX	VCGT110302R-FX			.0078		●	▲	●	▲		
VCGT220.5LFX	VCGT110302L-FX			.0078		●	▲	●	▲		
VCGT221RFX	VCGT110304R-FX			.0156		●	▲	●	▲		
VCGT221LFX	VCGT110304L-FX			.0156		●	▲	●	▲		

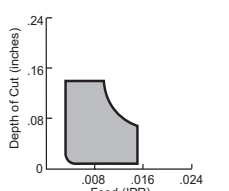
VCGT FY		Rake Angle:		Cutting Conditions:		Coated		Cermet		Uncoated	
  		Depth of Cut (inches) .24 .16 .08 0 .008 .016 .024 Feed (IPR)		Continuous Cut Medium Cut Interrupted Cut		● ○					
						● ○					
						● ○					
Sumitomo Catalog #	ISO Catalog #	I.C.	T	r	ød1	AC530U	ACZ310				
VCGT220RFY	VCGT110301R-FX	.250	.125	.0039	.110	★	▲				
VCGT220.5RFY	VCGT110302R-FX			.0078		★	▲				

VCGT NAG		Rake Angle: 8°		Cutting Conditions:		Coated		Cermet		Uncoated	
  		Depth of Cut (inches) .24 .16 .08 0 .008 .016 .024 Feed (IPR)		Continuous Cut Medium Cut Interrupted Cut						●	
										●	
										●	
Sumitomo Catalog #	ISO Catalog #	I.C.	T	r	ød1					H1	
VCGT220.5NAG	VCGT110302N-AG	.250	.125	.0078	.110					●	
VCGT221NAG	VCGT110304N-AG			.0156						●	
VCGT332NAG	VCGT160408N-AG			.375		.1875	.0313	.1732			



Positive Inserts

C

D

R

S

T

V

W

W

35° DIAMOND TYPE

POSITIVE INSERT

Indexable Inserts for Turning

VC

35° Diamond Type

7° Relief

With Insert Hole

- P** Steel
- M** Stainless Steel
- K** Cast Iron
- N** Non-ferrous
- S** Exotic Materials
- H** Hardened Steel

- USA Stocked Item
- ★ Worldwide Warehouse Item
- ▲ USA Limited Availability Item
- In stock by 1st Quarter 2017

Positive Inserts

C

D

R





S

T



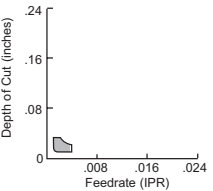

V

W

Swiss Tooling

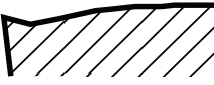
<h3>VC GT EFC</h3>		Rake Angle: 15° 	Cutting Conditions:						Coated			Cermet			Uncoated						
			Continuous Cut	Medium Cut	Interrupted Cut	●	●	●	●	●	●	●	●	●	●	●	●				
						AC530U															
Sumitomo Catalog #	ISO Catalog #	I.C.	T	r	ød1	●	●	●	●	●	●	●	●	●	●	●	●	●	●		
VC GT220EFC	VC GT110301N-FC	.250	.125	.0039	.110	●	●	●	●	●	●	●	●	●	●	●	●	●	●		
VC GT220MEFC	VC GT110301MN-FC			.0039		●	●	●	●	●	●	●	●	●	●	●	●	●	●	●	●
VC GT220.5EFC	VC GT110302N-FC			.0078		●	●	●	●	●	●	●	●	●	●	●	●	●	●	●	●
VC GT220.5MEFC	VC GT110302MN-FC			.0078		●	●	●	●	●	●	●	●	●	●	●	●	●	●	●	●
VC GT221EFC	VC GT110304N-FC			.0156		●	●	●	●	●	●	●	●	●	●	●	●	●	●	●	●
VC GT221MEFC	VC GT110304MN-FC			.0156		●	●	●	●	●	●	●	●	●	●	●	●	●	●	●	●

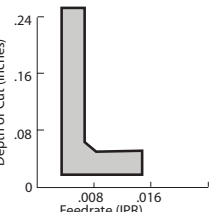
M = Negative nose radius tolerance (-0.0001" to -0.0004")

<h3>VC GT ESI</h3>		Rake Angle: 15° 	Cutting Conditions:						Coated			Cermet			Uncoated						
			Continuous Cut	Medium Cut	Interrupted Cut	●	●	●	●	●	●	●	●	●	●	●	●	●			
						AC530U	AC610M	AC6030M	AC630M	AC510U	AC520U	T1500Z	T1500A								
Sumitomo Catalog #	ISO Catalog #	I.C.	T	r	ød1	●	●	●	●	●	●	●	●	●	●	●	●	●	●		
VC GT220MESI	VC GT110301MN-SI	.250	.125	.0039	.110	●	●	●	●	●	●	●	●	●	●	●	●	●	●		
VC GT220.5MESI	VC GT110302MN-SI			.0078		●	●	●	●	●	●	●	●	●	●	●	●	●	●	●	●
VC GT221MESI	VC GT110304MN-SI			.0156		●	●	●	●	●	●	●	●	●	●	●	●	●	●	●	●
VC GT222MESI	VC GT110308MN-SI			.0313		●	●	●	●	●	●	●	●	●	●	●	●	●	●	●	●
VC GT330MESI	VC GT160401MN-SI			.0039		●	●	●	●	●	●	●	●	●	●	●	●	●	●	●	●
VC GT330.5MESI	VC GT160402MN-SI			.0078		●	●	●	●	●	●	●	●	●	●	●	●	●	●	●	●
VC GT331MESI	VC GT160404MN-SI	.0156	●	●	●	●	●	●	●	●	●	●	●	●	●	●	●	●			
VC GT332MESI	VC GT160408MN-SI	.0313	●	●	●	●	●	●	●	●	●	●	●	●	●	●	●	●			

M = Negative nose radius tolerance (-0.0001" to -0.0004")



VC

- 35° Diamond Type
- 7° Relief
- With Insert Hole

- P** Steel
- M** Stainless Steel
- K** Cast Iron
- N** Non-ferrous
- S** Exotic Materials
- H** Hardened Steel

- USA Stocked Item
- ★ Worldwide Warehouse Item
- ▲ USA Limited Availability Item
- In stock by 1st Quarter 2017

VCMT EFB		Rake Angle: 20°	Cutting Conditions:				Coated	Cermet	Uncoated				
			Continuous Cut					● ●					
			Medium Cut					● ●					
			Interrupted Cut					●					
		<p>Depth (Inches)</p> <p>Feed (Inches/Rev)</p>						T1500Z	T1500A				
Sumitomo Catalog #	ISO Catalog #	I.C.	T	r	ød1								
VCMT331EFB	VCMT160404N-FB	.375	.1875	.0156	.1732		★	●					
VCMT332EFB	VCMT160408N-FB			.0313			★	●					

VCMT EFP		Rake Angle: 10°	Cutting Conditions:				Coated	Cermet	Uncoated				
			Continuous Cut					● ●					
			Medium Cut					● ●					
			Interrupted Cut					●					
		<p>Depth (Inches)</p> <p>Feed (Inches/Rev)</p>						T2000Z	T1200A				
Sumitomo Catalog #	ISO Catalog #	I.C.	T	r	ød1								
VCMT331EFP	VCMT160404N-FP	.375	.1875	.0156	.1732		●	▲					
VCMT332EFP	VCMT160408N-FP			.0313			●	▲					

VCMT ENK		Rake Angle: 8°	Cutting Conditions:				Coated	Cermet	Uncoated				
			Continuous Cut				● ●						
			Medium Cut				● ● ●						
			Interrupted Cut				● ● ●						
		<p>Depth (Inches)</p> <p>Feed (IPR)</p>						AC8025P	AC820P	AC830P			
Sumitomo Catalog #	ISO Catalog #	I.C.	T	r	ød1								
VCMT331ENK	VCMT160404N-SK	.375	.1875	.0156	.1732		●	●	●				
VCMT332ENK	VCMT160408N-SK			.0313			●	●	●				

- Positive Inserts
- C
- D
- R
- S
- T
- V
- W
- Swiss Tooling



35° DIAMOND TYPE

POSITIVE INSERT

Indexable Inserts for Turning

VC

35° Diamond Type

7° Relief

With Insert Hole

- P** Steel
- M** Stainless Steel
- K** Cast Iron
- N** Non-ferrous
- S** Exotic Materials
- H** Hardened Steel

- USA Stocked Item
- ★ Worldwide Warehouse Item
- ▲ USA Limited Availability Item
- In stock by 1st Quarter 2017

Positive Inserts

C

D

R





S



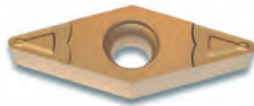

T

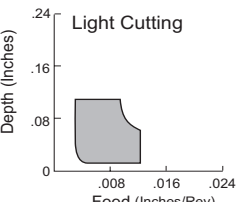

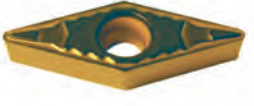

V

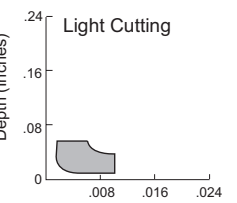
W

Swiss Tooling

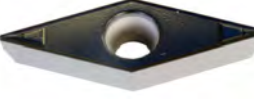
VCMT ESU		Rake Angle: 8°	Cutting Conditions:						Coated						Cermets		Uncoated			
			Continuous Cut	Medium Cut	Interrupted Cut	AC810P	AC8025P	AC820P	AC830P	AC610M	AC6020M	AC6030M	AC630M	AC510U	AC520U					
																				
Sumitomo Catalog #	ISO Catalog #	I.C.	T	r	ød1	AC810P	AC8025P	AC820P	AC830P	AC610M	AC6020M	AC6030M	AC630M	AC510U	AC520U					
VCMT220.5ESU	VCMT110302N-SU			.0078																
VCMT221ESU	VCMT110304N-SU	.250	.125	.0156	.110															
VCMT222ESU	VCMT110308N-SU			.0313																
VCMT331ESU	VCMT160404N-SU	.375	.1875	.0156	.1732	●	●	●	●	○	○	○	○	○	○	○	○	○	○	
VCMT332ESU	VCMT160408N-SU			.0313		●	●	●	●	○	○	○	○	○	○	○	○	○	○	

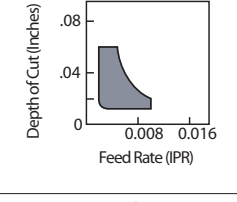
VCMT ELU		Rake Angle: 12°	Cutting Conditions:						Coated						Cermets		Uncoated			
			Continuous Cut	Medium Cut	Interrupted Cut	AC810P	AC8025P	AC820P	AC700G	AC6030M	AC630M					T1500Z	T2000Z	T3000Z		
																				
Sumitomo Catalog #	ISO Catalog #	I.C.	T	r	ød1	AC810P	AC8025P	AC820P	AC700G	AC6030M	AC630M					T1500Z	T2000Z	T3000Z		
VCMT331ELU	VCMT160404N-LU	.375	.1875	.0156	.1732	●	●	●	●	●	★					●	●	●		
VCMT332ELU	VCMT160408N-LU			.0313		●	●	●	●	●						★	●	●		

VCMT ELB		Rake Angle: 15°	Cutting Conditions:						Coated						Cermets		Uncoated			
			Continuous Cut	Medium Cut	Interrupted Cut	AC8025P														
																				
Sumitomo Catalog #	ISO Catalog #	I.C.	T	r	ød1	AC8025P														
VCMT331ELB	VCMT160404N-LB	.375	.1875	.0156	.1732	●														
VCMT332ELB	VCMT160408N-LB			.0313		●														



WB



80° Trigon Type

5° Relief

With Insert Hole

- P Steel
- M Stainless Steel
- K Cast Iron
- N Non-ferrous
- S Exotic Materials
- H Hardened Steel

- USA Stocked Item
- ★ Worldwide Warehouse Item
- ▲ USA Limited Availability Item
- In stock by 1st Quarter 2017

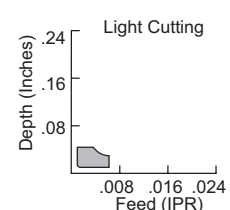
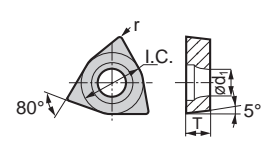
WBGT		Rake Angle: 15°	Cutting Conditions:				Coated				Cermet				Uncoated							
FW			Continuous Cut				●	●	●	●	●	●	●	●	●	●	●	●				
			Medium Cut				●	●	●	●	●	●	●	●	●	●	●	●				
		Interrupted Cut				●	●	●	●	●	●	●	●	●	●	●	●					
							T1500Z				T2000Z				T1500A				T1200A			
Sumitomo Catalog #		ISO Catalog #		I.C.	T	r	ød1															
WBGT520.5RFW		WBGT060102R-FW				.0078																
WBGT520.5LFW		WBGT060102L-FW		.156	.0625	.0078		●	●	●	●	●	●	●	●	●	●	●	●			
WBGT521RFW		WBGT060104R-FW				.0156																
WBGT521LFW		WBGT060104L-FW				.0156		●	●	●	●	●	●	●	●	●	●	●	●			
WBGT630.5RFW		WBGT080202R-FW				.0078	.090															
WBGT630.5LFW		WBGT080202L-FW		.1875	.094	.0078		●	●	●	●	●	●	●	●	●	●	●	●			
WBGT631RFW		WBGT080204R-FW				.0156																
WBGT631LFW		WBGT080204L-FW				.0156																

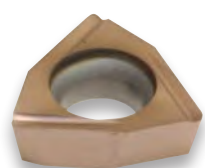
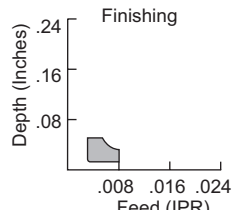
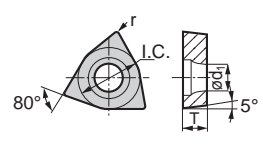
WBGT		Rake Angle: 15°	Cutting Conditions:				Coated				Cermet				Uncoated				
FX			Continuous Cut				●	○											
			Medium Cut				●	○											
		Interrupted Cut				●	○												
							AC530U				ACZ310								
Sumitomo Catalog #		ISO Catalog #		I.C.	T	r	ød1												
WBGT520.5RFX		WBGT060102R-FX		.156	.0625	.0078													
WBGT630.5RFX		WBGT080202R-FX				.0078		●	●	●	●	●	●	●	●	●	●	●	●
WBGT630.5LFX		WBGT080202L-FX		.1875	.094	.0078													
WBGT631RFX		WBGT080204R-FX				.0156		●	●	●	●	●	●	●	●	●	●	●	●
WBGT631LFX		WBGT080204L-FX				.0156		●	●	●	●	●	●	●	●	●	●	●	●

- Positive Inserts
- C
- D
- R
- S
- T
- V
- W
- Swiss Tooling



80° TRIGON TYPE

POSITIVE INSERT

Indexable Inserts for Turning

WB

80° Trigon Type

5° Relief

With Insert Hole

- P** Steel
- M** Stainless Steel
- K** Cast Iron
- N** Non-ferrous
- S** Exotic Materials
- H** Hardened Steel

- USA Stocked Item
- ★ Worldwide Warehouse Item
- ▲ USA Limited Availability Item
- In stock by 1st Quarter 2017

Positive Inserts

C

D

R















S

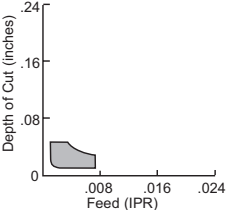





T

V

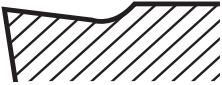
W

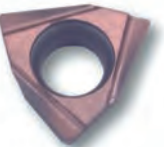
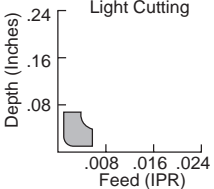
Swiss Tooling

WBGT		Rake Angle: 15°	Cutting Conditions:				Coated	Cermet		Uncoated			
FY			Continuous Cut										
			Medium Cut										
			Interrupted Cut										
Sumitomo Catalog #		ISO Catalog #	I.C.	T	r	ød1	AC530U	ACZ310	T1 500A	T1 200A			
WBGT52.001LFY	WBGT0601003L-FY				.0012								
WBGT520.5RFY	WBGT060102R-FY				.0078								
WBGT520.5LFY	WBGT060102L-FY				.0078								
WBGT520LFY	WBGT060101L-FY		.156	.0625	.0039	.090	●	▲	★	▲			
WBGT521RFY	WBGT060104R-FY				.0156				★				
WBGT521LFY	WBGT060104L-FY				.0156		▲		●	▲			

WBGT		Rake Angle: 10°	Cutting Conditions:				Coated	Cermet		Uncoated			
W			Continuous Cut										
			Medium Cut										
			Interrupted Cut										
Sumitomo Catalog #		ISO Catalog #	I.C.	T	r	ød1			T1 500Z	T1 500A			
WBGT520.5L	WBGT060102L-W				.0078				●				
WBGT521R	WBGT060104R-W				.0156				★				
WBGT521L	WBGT060104L-W		.156	.0625	.0156	.090			●	★			



Swiss Tooling Inserts

for precision turning applications:

- Cut-off
- Back Turn
- Boring Rough
- Boring Finishing

- P** Steel
- M** Stainless Steel
- K** Cast Iron
- N** Non-ferrous
- S** Exotic Materials
- H** Hardened Steel

- USA Stocked Item
- ★ Worldwide Warehouse Item
- ▲ USA Limited Availability Item
- In stock by 1st Quarter 2017

CTL CTR for SCT Type Holder (p. 313)						Coated	Cermet	Uncoated		
Sumitomo Catalog #	ISO Catalog #	t	R	W	H	AC530U				
CTL121005R	CTL121005R	1.0	0.05	19.0	7.0	★				
CTL121005N	CTL121005N					★				
CTL121005L	CTL121005L					★				
CTL121505R	CTL121505R	1.5						★		
CTL121505N	CTL121505N					★				
CTL121505L	CTL121505L					★				
CTL122005R	CTL122005R	2.0						★		
CTL122005N	CTL122005N					★				
CTL122005L	CTL122005L					★				
CTR121005R	CTR121005R	1.0						●		
CTR121005N	CTR121005N		●							
CTR121005L	CTR121005L		●							
CTR121505R	CTR121505R	1.5			●					
CTR121505N	CTR121505N		●							
CTR121505L	CTR121505L		●							
CTR122005R	CTR122005R	2.0			●					
CTR122005N	CTR122005N		●							

BTR for SBT Type Holder (p. 228)						Coated	Cermet	Uncoated
Sumitomo Catalog #	ISO Catalog #	I.C.	T	L	r	AC530U	T1500A	T1200A
BTR3505	BTR3505	6.8	3.8	3.5	0.05	●		
BTR3515	BTR3515			3.5	0.15	★	★	
BTR5505	BTR5505			5.5	0.05	★		
BTR5515	BTR5515			5.5	0.15	★		
BTR8005	BTR8005			8.0	0.05	★		
BTR8015	BTR8015			8.0	0.15	★		

Positive Inserts



Swiss Tooling



Swiss Tooling Inserts (cont.)

for precision turning applications:

- Cut-off
- Back Turn
- Boring/Roughing
- Boring Finishing

- P** Steel
- M** Stainless Steel
- K** Cast Iron
- N** Non-ferrous
- S** Exotic Materials
- H** Hardened Steel

- USA Stocked Item
- ★ Worldwide Warehouse Item
- ▲ USA Limited Availability Item
- In stock by 1st Quarter 2017

KBMXR

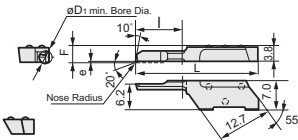

KBMZ

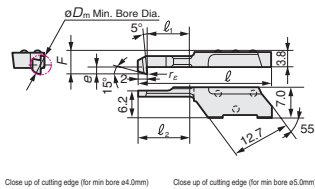

KBMFR

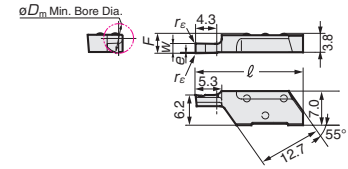

KBMXL

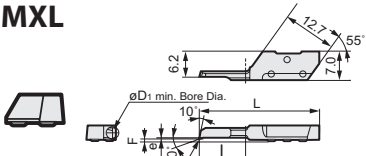

KBMG

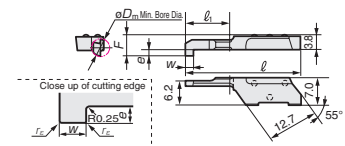

Left hand insert with right hand cut shown

Boring Rough Inserts (p. 234-235 for holder)

Sumitomo Catalog #	Dimensions (mm)						ACZ310	DA2200
	Min. Bore Dia.	F	e	Nose Radius	L	l		
KBMXR0103-05	1.0	4.00	0.20	0.05	20.5	3	▲	
KBMXR0103-20	1.0	4.00	0.20	0.20	20.5	3	★	
KBMXR01506-05	1.5	4.05	0.25	0.05	23.5	6	★	
KBMXR01506-20	1.5	4.05	0.25	0.20	23.5	6	★	
KBMXR0206-05	2.0	4.05	0.25	0.05	23.5	6	▲	
KBMXR0206-20	2.0	4.05	0.25	0.20	23.5	6	★	
KBMXR0311-05	3.0	4.10	0.30	0.05	28.5	11	★	
KBMXR0311-10	3.0	4.10	0.30	0.10	28.5	11	★	
KBMXR0311-20	3.0	4.10	0.30	0.20	28.5	11	★	
KBMXR0411-05	4.0	4.30	0.50	0.05	28.5	11	▲	
KBMXR0411-10	4.0	4.30	0.50	0.10	28.5	11	★	
KBMXR0411-20	4.0	4.30	0.50	0.20	28.5	11	▲	
KBMXR0420-05	4.0	4.30	0.50	0.05	37.5	20	▲	
KBMXR0420-20	4.0	4.30	0.50	0.20	37.5	20	▲	
KBMXR0511-05	5.0	4.50	0.70	0.05	28.5	11	▲	
KBMXR0511-10	5.0	4.50	0.70	0.10	28.5	11	★	
KBMXR0511-20	5.0	4.50	0.70	0.20	28.5	11	▲	
KBMXR0520-05	5.0	4.50	0.70	0.05	37.5	20	★	
KBMXR0520-20	5.0	4.50	0.70	0.20	37.5	20	★	

Boring Rough Inserts Right Hand Cut (p. 234-235 for holder)

Sumitomo Catalog #	Dimensions (mm)						ACZ310
	Min. Bore Dia.	F	e	Nose Radius	L	l	
KBMXL0206-05R	2.0	0.50	0.25	0.05	23.5	6	▲
KBMXL0206-20R	2.0	0.50	0.25	0.20	23.5	6	★
KBMXL0311-05R	3.0	0.50	0.30	0.05	28.5	11	★
KBMXL0311-20R	3.0	0.50	0.30	0.20	28.5	11	★
KBMXL0411-05R	4.0	0.50	0.50	0.05	28.5	11	▲
KBMXL0411-20R	4.0	0.50	0.50	0.20	28.5	11	▲
KBMXL0511-05R	5.0	0.50	0.50	0.05	28.5	11	★
KBMXL0511-20R	5.0	0.50	0.50	0.20	28.5	11	★
KBMXL0520-05R	5.0	0.50	0.50	0.05	37.5	20	★
KBMXL0520-20R	5.0	0.50	0.50	0.20	37.5	20	★

Back Boring (p. 234-235 for holder)

Sumitomo Catalog #	Dimensions (mm)							ACZ310
	Min. Bore Dia.	F	e	Nose Radius	L	l ₁	l ₂	
KBMZR0411-05	4.0	5.10	1.10	0.05	28.5	9	11	★
KBMZR0411-20				0.20				★
KBMZR0511-05	5.0	5.10	1.30	0.05	28.5	9	11	★
KBMZR0511-20				0.20				★

Boring Finishing Inserts (p. 234-235 for holder)

Sumitomo Catalog #	Dimensions (mm)						ACZ310	ACZ150
	Min. Bore Dia.	F	e	Nose Radius	L	l		
KBMXR0103-05T	1.0	4.00	0.20	0.05	20.5	3	▲	
KBMXR0103-20T	1.0	4.00	0.20	0.20	20.5	3	★	
KBMXR01506-05T	1.5	4.05	0.25	0.05	23.5	6	★	
KBMXR01506-20T	1.5	4.05	0.25	0.20	23.5	6	★	
KBMXR0206-05T	2.0	4.05	0.25	0.05	23.5	6	▲	
KBMXR0206-20T	2.0	4.05	0.25	0.20	23.5	6	★	
KBMXR0311-05T	3.0	4.10	0.30	0.05	28.5	11	★	
KBMXR0311-20T	3.0	4.10	0.30	0.20	28.5	11	★	
KBMXR0411-05T	4.0	4.30	0.50	0.05	28.5	11	▲	
KBMXR0411-20T	4.0	4.30	0.50	0.20	28.5	11	▲	
KBMXR0511-05T	5.0	4.50	0.70	0.05	28.5	11	▲	
KBMXR0511-20T	5.0	4.50	0.70	0.20	28.5	11	▲	

T = Free cutting

Face Grooving (p. 234-235 for holder)

Sumitomo Catalog #	Dimensions (mm)							ACZ150
	Min. Bore Dia.	W	F	e	Corner Radius	L	Maximum groove depth	
KBMFR0615-05	6.0	1.5	4.00	0.20	0.05	21.8	4.0	★
KBMFR0620-05	6.0	2.0	4.00	0.20	0.05	21.8	4.0	★
KBMFR0630-05	6.0	3.0	4.00	0.20	0.05	21.8	4.0	★

Internal Grooving (p. 234-235 for holder)

Sumitomo Catalog #	Dimensions (mm)							ACZ310
	Min. Bore Dia.	W	F	e	Corner Radius	L	l	
KBMGR0411-05	4.0	1.0	4.90	1.10	0.05	28.5	11	★
KBMGR0411-10		2.0			0.10			★
KBMGR0511-05	5.0	1.0	5.10	1.30	0.05	28.5	11	★
KBMGR0511-10		2.0			0.10			★



Swiss Tooling Inserts (cont.)

for precision turning applications:

- Cut-off
- Back Turn
- Boring Rough
- Boring Finishing

- P** Steel
- M** Stainless Steel
- K** Cast Iron
- N** Non-ferrous
- S** Exotic Materials
- H** Hardened Steel

- USA Stocked Item
- ★ Worldwide Warehouse Item
- ▲ USA Limited Availability Item
- In stock by 1st Quarter 2017

Blank Inserts for SPB Type holder (p. 233)				Uncoated	
Sumitomo Catalog #	Dim. E (mm)	Application	Fig.	BL130	
PBVX1102R-NB	17.20	General	1		
PBVX1102R-SB	20.14	Sharp Edge	2		
PBVX1102R-BB	14.20	Special	3		

Grooving Inserts for SPB Type holder (p. 233)				Uncoated	
Sumitomo Catalog #	Dimensions (mm)		BL130		
	Groove Depth	t			
PBVG1102R-030	0.5	0.3			
PBVG1102R-050	1.0	0.5			
PBVG1102R-100	2.0	1.0	★		

Turning Inserts for SPB Type holder (p. 233)				Uncoated	
Sumitomo Catalog #	Cutting Edge Width (mm)	Wiper Edge	Fig.	BL130	
PBVF1102R	1.0	Yes	1		
PBVF1102R	1.0	No	2		

Threading Inserts for SPB Type holder (p. 233)				Uncoated	
Sumitomo Catalog #	Pitch (mm)	Fig.	BL130		
PBVT1102R	0.2 ~ 0.5	1			
PBVT1102R	0.2 ~ 0.5	2			

Back Turning Inserts for SPB Type holder (p. 233)				Uncoated	
Sumitomo Catalog #	Cutting Edge Width (mm)	Wiper Edge	Fig.	BL130	
PBVB1102R	1.0	Yes	1		
PBVB1102R	1.0	No	2		

Cut-off Inserts for SPB Type holder (p. 233)				Uncoated	
Sumitomo Catalog #	Cutting Edge Width (mm)	Maximum Cut-off diameter	Fig.	BL130	
PBVC1102L-50	1.0	5.0	1		
PBVC1102R-50	1.0	5.0	2		

- Positive Inserts
- C
- D
- R
- S
- T
- V
- W
- Swiss Tooling





SUMITOMO

CARBIDE - CBN - DIAMOND

1-800-950-5202

www.sumicarbide.com

GROOVING, CUT-OFF & THREADING INSERTS

Pages 143-149

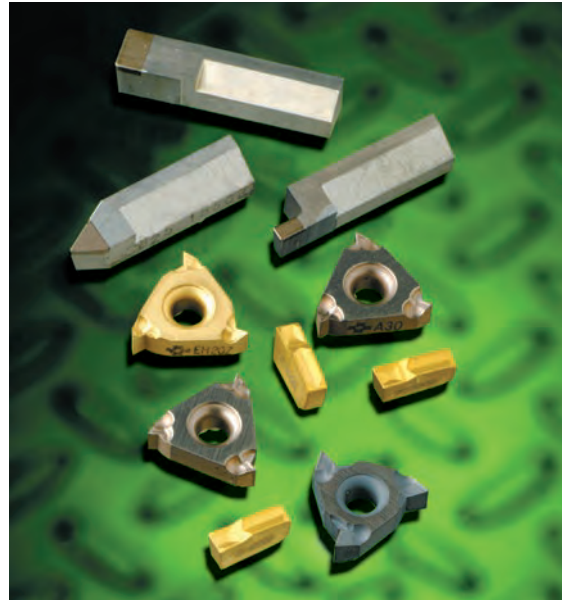

Threading,
Grooving &
Cut-off Inserts

GROOVING, CUT-OFF & THREADING INSERTS

PAGES

Grooving Inserts.....	144-146
Cut-Off Inserts.....	147
Threading Inserts	148-149

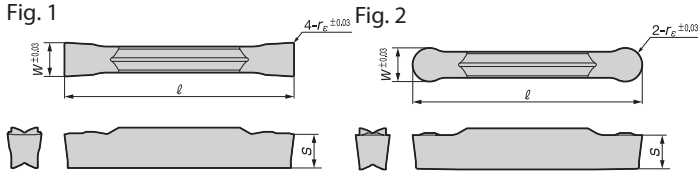

Threading, Grooving & Cut-off Inserts

Type	Cat. No.	Coated Carbide					Cermet	Uncoated Carbide	Dimensions (inch)					Figure
		S		K	P		N	W	r _f	ℓ	Seat	S		
		AC520U	AC530U	AC425K	AC830P	T2500A	H10							
Deep Grooving Cut Off	General Feed GG Type	GCMN2002-GG	●	●	●	●			.078	.0078	.831	2	.142	1
		GCMN2094R0.5-GG	●	●	●	●			.094	.0078	.831	2	.142	
		GCMN3002-GG	●	●	●	●			.118	.0078	.831	3	.150	
		GCMN3004-GG	●	●	●	●			.118	.0156	.831	3	.150	
		GCMN3125R0.5-GG	●	●	●	●			.125	.0078	.831	3	.150	
		GCMN4002-GG	●	●	●	●			.157	.0078	1.039	4	.157	
		GCMN4004-GG	●	●	●	●			.157	.0156	1.039	4	.157	
		GCMN5187R0.5-GG	●	●	●	●			.187	.0078	1.039	5	.161	
		GCMN5002-GG	●	●	●	●			.197	.0078	1.039	5	.161	
		GCMN5004-GG	●	●	●	●			.197	.0156	1.039	5	.161	
		GCMN6002-GG	●	●	●	●			.236	.0078	1.039	6	.177	
		GCMN6004-GG	●	●	●	●			.236	.0156	1.039	6	.177	
		GCMN6250R0.5-GG	●	●	●	●			.250	.0078	1.039	6	.177	
		GCMN6250R1.0-GG	●	●	●	●			.250	.0156	1.039	6	.177	
	GCMN7004-GG	●	●	●	●			.276	.0156	1.132	7	.217		
	GCMN8004-GG	●	●	●	●			.315	.0156	1.132	8	.236		
	Low Feed GL Type	GCMN2002-GL	●	●	●	●	○		.078	.0078	.831	2	.142	
		GCMN2094R0.5-GL	●	●	●	●			.094	.0078	.831	2	.142	
		GCMN3002-GL	●	●	●	●	○		.118	.0078	.831	3	.150	
		GCMN3125R0.5-GL	●	●	●	●			.125	.0078	.831	3	.150	
		GCMN4002-GL	●	●	●	●	○		.157	.0078	1.039	4	.157	
		GCMN5187R0.5-GL	●	●	●	●			.187	.0078	1.039	5	.161	
		GCMN5002-GL	●	●	●	●			.197	.0078	1.039	5	.161	
		GCMN6002-GL	●	●	●	●			.236	.0078	1.039	6	.177	
		GCMN6250R0.5-GL	●	●	●	●			.250	.0078	1.039	6	.177	
		GCMN7004-GL	●	●	●	●			.276	.0156	1.132	7	.217	
		GCMN8004-GL	●	●	●	●			.315	.0156	1.132	8	.236	
		Multi function (traversing)	General Feed MG Type	GCMN3004-MG	●	●	●	●			.118	.0156	.831	
GCMN3125R1.0-MG				●	●	●	●			.125	.0156	.831	3	.150
GCMN4008-MG				●	●	●	●			.157	.0312	1.039	4	.157
GCMN5187R2.0-MG	●			●	●	●			.187	.0312	1.039	5	.161	
GCMN5008-MG	●			●	●	●			.197	.0312	1.039	5	.161	
GCMN6008-MG	●			●	●	●			.236	.0312	1.039	6	.177	
GCMN6250R2.0-MG	●			●	●	●			.250	.0312	1.039	6	.177	
GCMN7008-MG	●			●	●	●			.276	.0313	1.132	7	.217	
GCMN8008-MG	●			●	●	●			.315	.0313	1.132	8	.236	
Low Feed ML Type	GCMN3002-ML			●	●	●	●	○		.118	.0078	.831	3	.150
	GCMN3125R0.5-ML		●	●	●	●			.125	.0078	.831	3	.150	
	GCMN4004-ML		●	●	●	●	○		.157	.0156	1.039	4	.157	
	GCMN5187R1.0-ML		●	●	●	●			.187	.0156	1.039	5	.161	
	GCMN5004-ML		●	●	●	●			.197	.0156	1.039	5	.161	
	GCMN6004-ML		●	●	●	●			.236	.0156	1.039	6	.177	
	GCMN6250R1.0-ML		●	●	●	●			.250	.0156	1.039	6	.177	
	GCMN7004-ML		●	●	●	●			.276	.0156	1.132	7	.217	
	GCMN8004-ML		●	●	●	●			.315	.0156	1.132	8	.236	
	Profiling		General Feed RG Type	GCMN3015-RG	●	●	●	●	○		.118	.059	.831	3
GCMN3125-RG				●	●	●	●			.125	.0625	.831	3	.150
GCMN4020-RG		●		●	●	●	○		.157	.078	1.039	4	.157	
GCMN5187-RG		●		●	●	●			.187	.0938	1.039	5	.161	
GCMN5025-RG		●		●	●	●			.197	.098	1.039	5	.161	
GCMN6030-RG		●		●	●	●			.236	.118	1.039	6	.177	
GCMN6250-RG		●		●	●	●			.250	.125	1.039	6	.177	
GCMN7035-RG		●		●	●	●			.276	.138	1.144	7	.217	
GCMN8040-RG	●	●	●	●			.315	.157	1.152	8	.236			



GND Series - Inserts Cont'd

Type	Cat. No.	Coated Carbide						Cermet	Uncoated Carbide	Dimensions (inch)					Figure						
		S		K		P				N	W	r _s	ℓ	Seat		S					
		AC520U	AC530U	AC425K	AC830P	T2500A	H10			○											
For Non-ferrous Materials	GA Type	GCGN2002-GA							○	.078	.0078	.831	2	.142	1						
		GCGN3002-GA							○	.118	.0078	.831	3	.150							
		GCGN4004-GA							○	.157	.0156	1.039	4	.157							
		GCGN5004-GA							○	.197	.0156	1.039	5	.161							
		GCGN6004-GA							○	.236	.0156	1.039	6	.177							
Type	Cat. No.	R	L	R	L	R	L	R	L	R	L	R	L	Dimensions (inch)					Figure		
Cut-off (Handed)	CG-05 Type	GCM_2002-CG-05	●	●	●	●	●	●	●	●					.078	.0078	.831	2		.142	1
		GCM_3002-CG-05	●	●	●	●	●	●	●	●					.118	.0078	.831	3		.150	
		GCM_4002-CG-05	●	●	●	●	●	●	●	●					.157	.0078	1.039	4	.157		

Threading, Grooving & Cut-off Inserts

SumiNotch GROOVING INSERTS

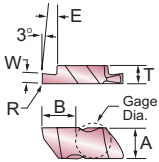

- USA Stocked Item
- ★ Worldwide Warehouse Item
- ▲ USA Limited Availability Item
- In stock by 1st Quarter 2017

Left		Dimension (in)										Right			
SG	Coated	W ± .001	R	E ± .001	T	A	B	Gage Dia.	SG	Coated	BN2000	BN350	Ceramic		
	EH520V									BN2000				BN350	SN2000K
SG-2031L	●	.031	.002/.005	.050					SG-2031R	●					
SG-2041L	●	.041	.002/.005	.050					SG-2041R	●					
SG-2047L	●	.047	.002/.005	.050					SG-2047R	●					
SG-2058L	●	.058	.005/.010	.050	.150	.219	.2700	.1875	SG-2058R	●					
SG-2062L	●	.062	.005/.010	.110					SG-2062R	●					
SG-2094L	●	.094	.005/.010	.110					SG-2094R	●					
SG-2125L	●	.125	.005/.010	.110					SG-2125R	●					
SG-3047L	●	.047	.005/.010	.120					SG-3047R	●	●	●	●		
SG-3062L	●	.062	.005/.010	.120					SG-3062R	●	●	●	●		
SG-3072L	●	.072	.005/.010	.120					SG-3072R	●					
SG-3088L	●	.088	.005/.010	.180					SG-3088R	●					
SG-3094L	●	.094	.005/.010	.180					SG-3094R	●	●	●	●		
SG-3097L	●	.097	.005/.010	.180					SG-3097R	●					
SG-3105L	●	.105	.005/.010	.180					SG-3105R	●					
SG-3110L	●	.110	.005/.010	.180	.195	.344	.4050	.3750	SG-3110R	●					
SG-3122L	●	.122	.005/.010	.180					SG-3122R	●					
SG-3125L	●	.125	.005/.010	.180					SG-3125R	●	●	●	●		
SG-3142L	●	.142	.005/.010	.180					SG-3142R	●					
SG-3156L	●	.156	.005/.010	.180					SG-3156R	●					
SG-3178L	●	.178	.005/.010	.180					SG-3178R	●					
SG-3185L	●	.185	.020/.025	.180					SG-3185R	●					
SG-3189L	●	.189	.020/.025	.180					SG-3189R	●	●				

Left		Dimension (in)							Right	
SG-CB	Coated	W ± .001	R	E ± .001	T	A	B	Gage Dia.	SG	Coated
	EH520V									EH520V
SG-2047L-CB	●	.047	.002/.005	.050					SG-2047R-CB	●
SG-2062L-CB	●	.062	.005/.010	.110					SG-2062R-CB	●
SG-2078L-CB	●	.078	.005/.010	.110	.150	.219	.2700	.1875	SG-2078R-CB	●
SG-2094L-CB	●	.094	.005/.010	.110					SG-2094R-CB	●
SG-2125L-CB	●	.125	.005/.010	.110					SG-2125R-CB	●
SG-3047L-CB	●	.047	.005/.010	.075					SG-3047R-CB	●
SG-3062L-CB	●	.062	.005/.010	.094					SG-3062R-CB	●
SG-3072L-CB	●	.072	.005/.010	.094					SG-3072R-CB	●
SG-3078L-CB	●	.078	.005/.010	.094	.195	.344	.4050	.3750	SG-3078R-CB	●
SG-3088L-CB	●	.088	.005/.010	.094					SG-3088R-CB	●
SG-3094L-CB	●	.094	.005/.010	.150					SG-3094R-CB	●
SG-3189L-CB	●	.189	.020/.025	.150					SG-3189R-CB	●

GROOVING INSERTS FOR CF HOLDERS

Sumitomo Catalog No.	Uncoated	Dimensions (in)		Holder
		B	T	
CFB3	●	.118	.1875	CF3-3
CFB3T	●			

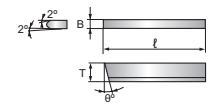

GROOVING INSERTS

CGA • BNGNT

Indexable Inserts for Grooving

BNC30G



BN2000

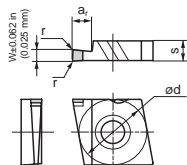

- USA Stocked Item
- ★ Worldwide Warehouse Item
- ▲ USA Limited Availability Item
- In stock by 1st Quarter 2017

GROOVING INSERTS FOR GWB HOLDERS

CGA	Coated	Uncoated	Dimensions				
	BNC30G	BN2000	W ± .001 in. ± .025 (mm)	a _r in (mm)	r in (mm)	ød in (mm)	s in (mm)
CGAR4062	●	●	.062 (1.575)	.1378 (3.5)	.0078 (.2)	.625 (15.875)	.1875 (4.76)
CGAL4062							
CGAR4094	●	●	.094 (2.388)	.1575 (4.0)			
CGAL4094							
CGAR4125	●	●	.125 (3.175)	.1969 (5.0)			
CGAL4125							
CGAR6189	●	●	.189 (4.801)			.25 (6.35)	
CGAL6189							
CGAR1504150	●		.0591 (1.5)	.1378 (3.5)	.0078 (.2)	.625 (15.875)	.1875 (4.76)
CGAL1504150		●					
CGAR1504200	●	●	.0787 (2.0)				
CGAL1504200							
CGAR1504250	●		.0984 (2.5)	.1575 (4.0)			
CGAL1504250		●					
CGAR1504300	●	●	.1181 (3.0)				
CGAL1504300							
CGAR1504350	●		.1378 (3.5)	.1969 (5.0)			
CGAL1504350							
CGAR1504400	●	●	.1575 (4.0)				
CGAL1504400							
CGAR1504450	●		.1772 (4.5)				
CGAL1504450							
CGAR1506500	●	●	.1969 (5.0)			.25 (6.35)	
CGAL1506500							
CGAR1506550	●		.2165 (5.5)				
CGAL1506550							
CGAR1506600	●	●	.2362 (6.0)				
CGAL1506600							

GROOVING INSERTS FOR BNGG HOLDERS

BNGNT <i>for holders (p. 263)</i>	CBN		Dimensions (mm)				
	BN250	BN350	W	I	R	L	S
BNGNT0200L	●		2.0	4.0	0.2	25.0	6.0
BNGNT0200R	●	●					
BNGNT0250L	●		2.5	4.0	0.2	25.0	6.0
BNGNT0250R	●						
BNGNT0300L	●		3.0	5.0	0.4	25.0	6.0
BNGNT0300R	●	●					
BNGNT0400L	●		4.0	6.0	0.4	26.0	6.0
BNGNT0400R	●	●					
BNGNT0500L			5.0	6.0	0.4	26.0	6.0
BNGNT0500R	●						
BNGNT0600L			6.0	7.0	0.4	27.0	6.0
BNGNT0600R	●						

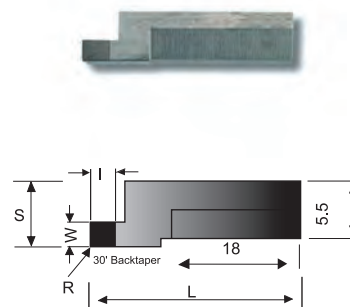

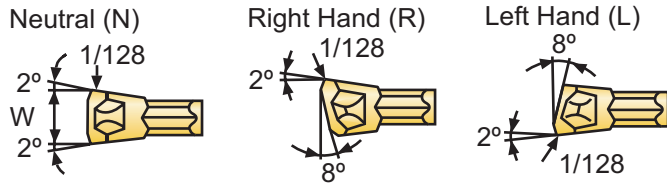

- USA Stocked Item
- ★ Worldwide Warehouse Item
- ▲ USA Limited Availability Item
- In stock by 1st Quarter 2017

WCF□○□ General Steel			WCF□○A Hard-to-cut metals Slow feed			WCF□○GF Hard-to-cut metals Slow feed			WCF□○CF Hard-to-cut metals Slow feed			WCF□○B Cast iron Aluminum alloy		
Catalog Number	Coated AC830P	W	Catalog Number	Coated AC1030U	Coated AC225	Cermet T130A	Uncoated A30 G10E		W	Catalog Number	Uncoated G10E	W		
WCFN2T	●	.0787	WCFN2-GF	●					.0787					
WCFR2T	●		WCFN3A		●	●	●	●	.1181	WCFN3B	●	.1181		
WCFN2-GG	●		WCFR3A		●	●	●	▲		WCFR3B	●			
WCFN3	●	WCFL3A		●	●	●	●	WCFL3B		●				
WCFR3	●	.1181	WCFN3-GF	●					.1575	WCFN4B	●	.1575		
WCFL3	●		WCFR3-CF	●						WCFR4B	●			
WCFN3-GG	●		WCFL3-CF	●						WCFL4B	●			
WCFN4	●	.1575	WCFN4A		●	●		●	.1969	WCFN5B	●	.1969		
WCFR4	●		WCFR4A		●					WCFR5B	●			
WCFL4	●		WCFL4A							WCFL5B	●			
WCFN4-GG	●	.1969	WCFN4-GF	●					.1969					
WCFN5	●		WCFR4-CF	●										
WCFR5	●		WCFL4-CF	●										
WCFL5	●	.1969	WCFN5A		●	●		●	.1969					
WCFN5-GG	●		WCFR5A		●									
			WCFL5A											
			WCFN5-GF	●										

Threading,
Grooving &
Cut-off Inserts



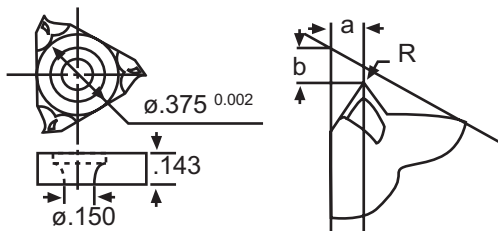

- USA Stocked Item
- ★ Worldwide Warehouse Item
- ▲ USA Limited Availability Item
- In stock by 1st Quarter 2017

EXTERNAL LAYDOWN - Full Profile (ISO Metric) *for holders (p. 305)*

Sumitomo Catalog Number	Pitch (mm)	Threads/in	Stock Grade		R	Included Angle θ°	a	b
			Coated	Cermet				
			AC225	T130A				
TME100R	1.00	-	●	●	.0050	60	.031	.047
TME125R	1.25	-	●	●	.0067			
TME150R	1.50	-	●	●	.0080			
TME175R	1.75	-	●	●	.0094			
TME200R	2.00	-	●	●	.0106			
TME250R	2.50	-	●	●	.0140			
TME300R	3.00	-	●	●	.0165			

Full Profile (Inch)

Sumitomo Catalog Number	Pitch (mm)	Threads/in	Stock Grade		R	Included Angle θ°	a	b
			Coated	Cermet				
			AC225	T130A				
TUE24R	-	24	●	●	.0047	60	.031	.047
TUE20R	-	20	●	●	.0059			
TUE18R	-	18	●	●	.0067			
TUE16R	-	16	●	●	.0079			
TUE14R	-	14	●	●	.0091			
TUE12R	-	12	●	●	.0110			
TUE08R	-	8	●	●	.0169			

Partial Profile (60°)

Sumitomo Catalog Number	Pitch (mm)	Threads/in	Stock Grade		R	Included Angle θ°	a	b
			Coated	Cermet				
			AC225	T130A				
TME1020R	1.0 ~ 2.0	24 ~ 12	●	●	.005	60	.043	.047
TME1530R	1.50 ~ 3.00	16 ~ 8	●	●	.008			

Partial Profile (55°)

Sumitomo Catalog Number	Inch	Threads/in	Stock Grade		R	Included Angle θ°	a	b
			Coated	Cermet				
			AC225	T130A				
TWE1410R	-	14 ~ 10	●	●	.009	55	.055	.047
TWE2416R	-	24 ~ 16	●	●	.005			



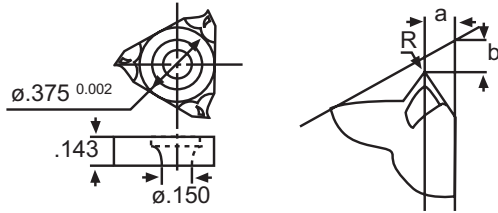

- USA Stocked Item
- ★ Worldwide Warehouse Item
- ▲ USA Limited Availability Item
- In stock by 1st Quarter 2017

INTERNAL LAYDOWN - Full Profile (ISO Metric)

Sumitomo Catalog Number	Pitch (mm)	Threads/in	Stock Grade		R	Included Angle θ°	a	b
			Coated	Cermet				
			AC225	T130A				
TMI100R	1.00	-	●		.0024	60	.031	.047
TMI125R	1.25	-	●		.0030			
TMI150R	1.50	-	●	●	.0035			
TMI175R	1.75	-	●		.0043			
TMI200R	2.00	-	●	●	.0050			
TMI250R	2.50	-	●		.0063			
TMI300R	3.00	-	●	●	.0080			

Partial Profile (60°)

Sumitomo Catalog Number	Pitch (mm)	Threads/in	Stock Grade		R	Included Angle θ°	a	b
			Coated	Cermet				
			AC225	T130A				
TMI1020R	1.0 ~ 2.0	24 ~ 12	●	●	.0024	60	.039	.047
TMI1530R	1.50 ~ 3.00	16 ~ 8	●	●	.0035			

Partial Profile (NPT)

Sumitomo Catalog Number	Pitch (mm)	Threads/in	Stock Grade		R	Included Angle θ°	a	b
			Coated	Cermet				
			AC225	T130A				
TNPT115R	-	11.5	●	●	.0004	60	.059	.043

THREADING INSERTS FOR BGG HOLDERS

Sumitomo Catalog Number	Pitch (mm)	Threads/in	Stock Grade		R	Included Angle θ°	a	b
			CBN					
			BN250					
BNTT1020R	1.0 ~ 2.0	-	●		.0024	60	.039	.047
BNTT1530R	1.50 ~ 3.00	-	●		.0035			

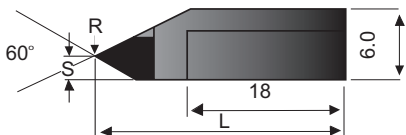



SUMITOMO

CARBIDE - CBN - DIAMOND

1-800-950-5202

www.sumicarbide.com



CERAMIC INSERTS

Pages 151-155

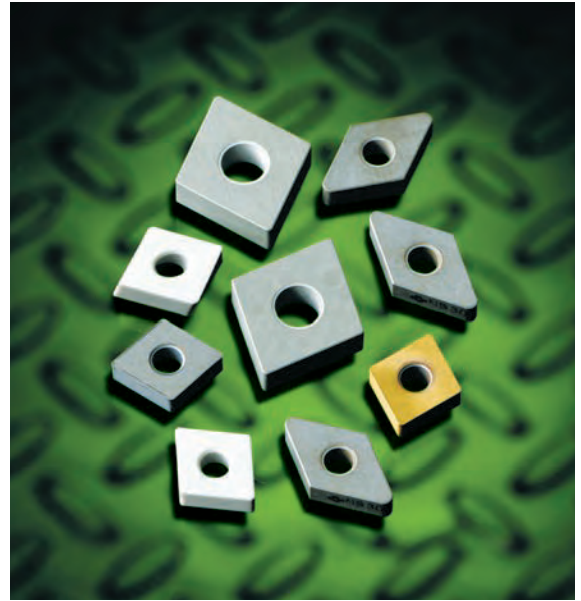

Ceramic Inserts

CERAMIC INSERTS	PAGES
Ceramic Inserts	151-155

CERAMIC INSERTS - NEGATIVE

Advanced Cutting Materials

SN2000K* → Finishing and roughing of cast iron

SN2100K* → Interrupted turning /milling of cast iron

SN1000S → SiAlON grade for continuous turning of exotic alloys

SN2000S → SiAlON grade for continuous to medium interrupted turning of exotic alloys

*SN2000K & SN2100K grades not shown in stock can be made to order. Call for price and delivery.

WX1500 → Cold pressed whiskered ceramic grade for continuous turning of exotic alloys

WX2500 → High speed turning of super alloys

WX2000 → High speed turning of super alloys

NB150H → High speed finishing of hardened steels

NB90S → High speed finishing of hardened steels

■ NEGATIVE

● USA Stocked Item ★ Worldwide Warehouse Item ▲ USA Limited Availability Item ○ In stock by 1st Quarter 2017

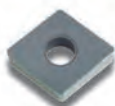
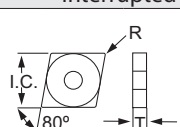
CNMA	Cutting Conditions:				
	Continuous Cut				
	Medium Cut				
	Interrupted Cut				
					SN2000K
Catalog #	I.C.	T	r	Hole Dia.	
CNMA432	.500	.1875	.0313	.2031	●
CNMA433			.0469		●
CNMA434			.0625		●
CNMA454			.3125		.0625
CNMA543	.625	.250	.0469	.250	●
CNMA544			.0625		●

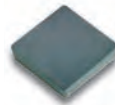
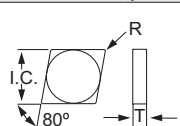
CNMN	Cutting Conditions:				
	Continuous Cut				
	Medium Cut				
	Interrupted Cut				
					SN2000K
Catalog #	I.C.	T	r	Hole Dia.	
CNMN434	.500	.1875	.0625	-	●

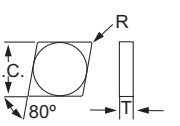
CNGX	Cutting Conditions:				
	Continuous Cut				
	Medium Cut				
	Interrupted Cut				
					SN2000K
Catalog #	I.C.	T	r	Hole Dia.	
CNGX452	.500	.3125	.0313	-	●

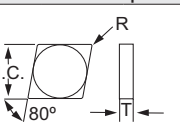
CNMX	Cutting Conditions:				
	Continuous Cut				
	Medium Cut				
	Interrupted Cut				
					SN2000K
Sumitomo Catalog #	I.C.	T	r	Hole Dia.	
CNMX453	.500	.3125	.0469	-	●
CNMX454	.500	.3125	.0625	-	●

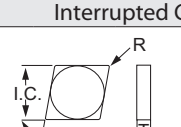
CNG	Cutting Conditions:					Grades		
	Continuous Cut					●	●	●
	Medium Cut					●	●	●
	Interrupted Cut					●	●	●
					SN2000K	WX2000	NB90S	
Catalog #	I.C.	T	r	Hole Dia.				
CNG432	.500	.1875	.0313	-	●	●	●	
CNG433			.0469		●	●	●	
CNG434			.0625		●	●	●	
CNG452			.0313		●	●	●	
CNG453	.3125	.0469	.0469	-	●	●	●	
CNG454			.0625		●	●	●	
CNG643			.250		.0469	●	●	●

K Cast Iron
S Exotic Materials
H Hardened Steel

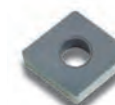
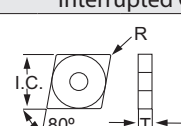
CNGA	Cutting Conditions:					Grades											
	Continuous Cut					●	●	●	●	●	●	●	●	●	●	●	●
	Medium Cut					●	●	●	●	●	●	●	●	●	●	●	●
	Interrupted Cut					●	●	●	●	●	●	●	●	●	●	●	●
					SN2000K	SN2100K	SN1000S	SN2000S	WX1500	WX2500	WX2000	NB150H	NB90S				
Catalog #	I.C.	T	r	Hole Dia.													
CNGA431	.500	.1875	.0156	.2031	●	●	○	○	○	○	▲	○	▲				
CNGA432			.0313		●	●	○	○	○	○	○	○	○	○	○		
CNGA433			.0469		●	●	○	○	○	○	○	○	○	○	○	○	
CNGA434			.0625		●	●	○	○	○	○	○	○	○	○	○	○	
CNGA542	.625	.250	.0313	.250	●	●	○	○	○	○	○	○	○				
CNGA543			.0469		●	●	○	○	○	○	○	○	○	○			
CNGA544			.0625		●	●	○	○	○	○	○	○	○	○	○		
CNGA643	.750	.250	.0469	.3126	●	●	○	○	○	○	○	○	○				
CNGA644			.0625		●	●	○	○	○	○	○	○	○	○			

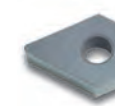
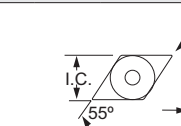
DNGA	Cutting Conditions:					Grades						
	Continuous Cut					●	●	●	●	●	●	●
	Medium Cut					●	●	●	●	●	●	●
	Interrupted Cut					●	●	●	●	●	●	●
					SN2000K	SN1000S	SN2000S	WX2500	WX2000	NB150H	NB90S	
Catalog #	I.C.	T	r	Hole Dia.								
DNGA432	.500	.1875	.0313	.2031	●	○	○	○	▲	○	▲	
DNGA433			.0469		●	○	○	○	○	○	○	○
DNGA434			.0625		●	○	○	○	○	○	○	○



- SN2000K*** → Finishing and roughing of cast iron
- SN2100K*** → Interrupted turning /milling of cast iron
- SN1000S** → SiAlON grade for continuous turning of exotic alloys
- SN2000S** → SiAlON grade for continuous to medium interrupted turning of exotic alloys

*SN2000K & SN2100K grades not shown in stock can be made to order. Call for price and delivery.

- USA Stocked Item
- ★ Worldwide Warehouse Item
- ▲ USA Limited Availability Item
- In stock by 1st Quarter 2017

- K** Cast Iron
- S** Exotic Materials
- H** Hardened Steel

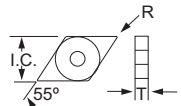
DNMX					
Cutting Conditions:					
Continuous Cut					
Medium Cut					
Interrupted Cut					
					
Catalog #	I.C.	T	r	Hole Dia.	SN2000K
DNMX354	.375	.3125	.0625	.2031	●
DNMX454	.500		.0625		●

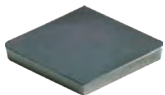
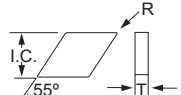
DNG					
Cutting Conditions:					
Continuous Cut					
Medium Cut					
Interrupted Cut					
					
Catalog #	I.C.	T	r	Hole Dia.	SN2000K
DNG432			.0313		●
DNG433	.500	.1875	.0469	.2031	●
DNG434			.0625		●

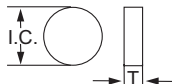
RNG						Grades									
Cutting Conditions:															
Continuous Cut						●	●	○	○	○	○	○	○	○	○
Medium Cut						●	●	○	○	○	○	○	○	○	○
Interrupted Cut						●	●	○	○	○	○	○	○	○	○
															
Catalog #	I.C.	T	r	Hole Dia.	SN2000K	SN2100K	SN1000S	SN2000S	WX1500	WX2500	WX2000	NB150H	NB90S		
RNG32	.375	.125			●	●	○	○	○	○	○	○	▲		
RNG33		.1875			●	●	○	○	○	○	○	○	▲		
RNG42		.125			●	●	○	○	○	○	○	○	▲		
RNG43	.500	.1875	-	-	●	●	○	○	○	○	○	○	▲		
RNG45					●	●	○	○	○	○	○	○	▲		
RNG55	.625	.3125			●	●	○	○	○	○	○	○	○		
RNG65	.750				○	○	○	○	○	○	○	○	○		
RNG86	1.00	.375	-	-	○	○	○	○	○	○	○	○	○		

- WX1500** → Cold pressed whiskered ceramic grade for continuous turning of exotic alloys
- WX2500** → High speed turning of super alloys
- WX2000** → High speed turning of super alloys
- NB150H** → High speed finishing of hardened steels
- NB90S** → High speed finishing of hardened steels

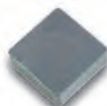
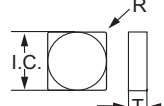
SNMN					
Cutting Conditions:					
Continuous Cut					
Medium Cut					
Interrupted Cut					
					
Catalog #	I.C.	T	r	Hole Dia.	SN2000K
SNMN434	.500	.1875	.0625	.2031	●

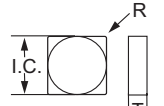
SNMX					
Cutting Conditions:					
Continuous Cut					
Medium Cut					
Interrupted Cut					
					
Catalog #	I.C.	T	r	Hole Dia.	SN2000K
SNMX453	.500		.0469		●
SNMX454	.500	.3125	.0625	-	●
SNMX554	.625		.0625		●

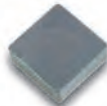
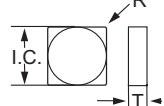
SNG						Grades		
Cutting Conditions:								
Continuous Cut						●	●	○
Medium Cut						●	●	○
Interrupted Cut						●	●	○
								
Catalog #	I.C.	T	r	Hole Dia.	SN2000K	SN2100K	WX2000	
SNG432			.0313		●	●	○	
SNG433	.500	.1875	.0469	-	●	●	○	
SNG434			.0625		●	●	○	

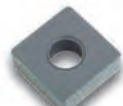
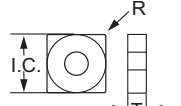
SNGA						Grades		
Cutting Conditions:								
Continuous Cut						●	●	○
Medium Cut						●	●	○
Interrupted Cut						●	●	○
								
Catalog #	I.C.	T	r	Hole Dia.	SN2000K	WX2000	NB90S	
SNGA432			.0313		●	●	○	
SNGA433	.500	.1875	.0469	.2031	●	●	○	
SNGA434			.0625		●	●	○	



CERAMIC INSERTS - NEGATIVE

Advanced Cutting Materials

*SN2000K & SN2100K grades not shown in stock can be made to order. Call for price and delivery.

- K** Cast Iron
- S** Exotic Materials
- H** Hardened Steel

- USA Stocked Item
- ★ Worldwide Warehouse Item
- ▲ USA Limited Availability Item
- In stock by 1st Quarter 2017

- SN2000K*** → Finishing and roughing of cast iron
- SN2100K*** → Interrupted turning /milling of cast iron
- SN1000S** → SiAlON grade for continuous turning of exotic alloys
- SN2000S** → SiAlON grade for continuous to medium interrupted turning of exotic alloys
- WX1500** → Cold pressed whiskered ceramic grade for continuous turning of exotic alloys
- WX2500** → High speed turning of super alloys
- WX2000** → High speed turning of super alloys
- NB150H** → High speed finishing of hardened steels
- NB90S** → High speed finishing of hardened steels

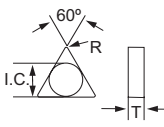
TNG	Cutting Conditions:				Grades	
	Continuous Cut				●	●
	Medium Cut				●	●
Interrupted Cut				●	●	
					SN2000K	NB90S
Catalog #	I.C.	T	r	Hole Dia.		
TNG321	.375	.125	.0156	.150	●	●
TNG322			.0313		●	●
TNG331			.0156		●	●
TNG332	.1875	.3125	.0313	-	●	●
TNG333			.0469		●	●
TNG334			.0625		●	●
TNG352	.500	.3125	.0313	-	●	●
TNG353			.0469		●	●
TNG432	.500	.3125	.0313	.2031	●	●
TNG433			.0469		●	●
TNG434			.0625		●	●
TNG436			.0938		●	●

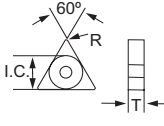
TNGA	Cutting Conditions:				Grades	
	Continuous Cut				●	●
	Medium Cut				●	●
Interrupted Cut				●	●	
					SN2000K	NB90S
Catalog #	I.C.	T	r	Hole Dia.		
TNGA321	.375	.125	.0156	.150	●	●
TNGA322			.0313		●	●
TNGA332			.0313		●	●
TNGA333	.1875	.3125	.0469	.2031	●	●
TNGA334			.0625		●	●
TNGA432			.0313		●	●
TNGA433	.500	.3125	.0469	.250	●	●
TNGA434			.0625		●	●
TNGA436			.0938		●	●
TNGA438			.1250		●	●
TNGA543	.625	.250	.0469	.250	●	●
TNGA544			.0625		●	●

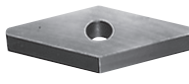
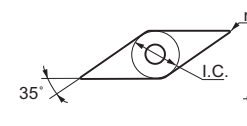
VNGA	Cutting Conditions:				Grades		
	Continuous Cut				●	●	●
	Medium Cut				●	●	●
Interrupted Cut				●	●	●	
					SN2000K	WX2000	NB90S
Catalog #	I.C.	T	r	Hole Dia.			
VNGA331	.375	.1875	.0156	.150	●	●	●
VNGA332			.0313		●	●	
VNGA333			.0469		●	●	
VNGA432	.500	.1875	.0313	.2031	●	●	●
VNGA433			.0469		●	●	

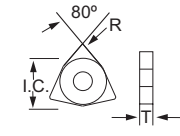
WNGA	Cutting Conditions:				Grades					
	Continuous Cut				●	●	●	●	●	●
	Medium Cut				●	●	●	●	●	●
Interrupted Cut				●	●	●	●	●	●	
					SN2000K	SN2100K	SN1000S	SN2000S	WX2000	NB150H
Catalog #	I.C.	T	r	Hole Dia.						
WNGA432	.500	.1875	.0313	.2031	●	●	○	○	●	●
WNGA433			.0469		●	○	○	●	●	
WNGA434			.0625		○	○	●	●		

POSITIVE

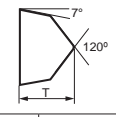
RCGX	Cutting Conditions:				Grades							
	Continuous Cut				●	●	●	●	●	●		
	Medium Cut				●	●	●	●	●	●		
Interrupted Cut				●	●	●	●	●	●			
					SN2000K	SN1000S	SN2000S	WX1500	WX2500	WX2000	NB150H	NB90S
Catalog #	I.C.	T	r	Hole Dia.								
RCGX35	.375	.3125	-	-	●	○	○	○	○	▲	●	
RCGX45	.500		●	○	○	○	○	○	○	▲	●	
RCGX55	.625		○	○	○	○	○	○	○	●	●	

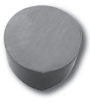
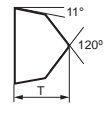
RPGX	Cutting Conditions:				Grades				
	Continuous Cut				●	●	●	●	●
	Medium Cut				●	●	●	●	●
Interrupted Cut				●	●	●	●	●	
					SN1000S	SN2000S	WX1500	WX2500	WX2000
Catalog #	I.C.	T	r	Hole Dia.					
RPGX35	.375	.3125	-	-	○	○	○	○	▲
RPGX45	.500		○	○	○	○	○	○	▲
RPGX55	.625		○	○	○	○	○	○	○



SN2000K* → Finishing and roughing of cast iron

SN2100K* → Interrupted turning /milling of cast iron

SN1000S → SiAlON grade for continuous turning of exotic alloys

SN2000S → SiAlON grade for continuous to medium interrupted turning of exotic alloys

*SN2000K & SN2100K grades not shown in stock can be made to order. Call for price and delivery.

- USA Stocked Item
- ★ Worldwide Warehouse Item
- ▲ USA Limited Availability Item
- In stock by 1st Quarter 2017

WX1500 → Cold pressed whiskered ceramic grade for continuous turning of exotic alloys

WX2500 → High speed turning of super alloys

WX2000 → High speed turning of super alloys

NB150H → High speed finishing of hardened steels

NB90S → High speed finishing of hardened steels

- K** Cast Iron
- S** Exotic Materials
- H** Hardened Steel

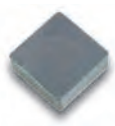
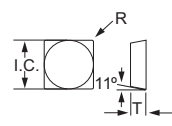
SPG	Cutting Conditions:				Grades		
	Continuous Cut				●	●	●
	Medium Cut				●	●	●
Interrupted Cut				●	●	●	
					SN2000K	SN2100K	NB90S
Catalog #	I.C.	T	r	Hole Dia.			
SPG422	.500	.125	.0313	-	●	●	●
SPG423			.0469		●	●	
SPG424			.0625		●	●	
SPG432			.0313		●	●	
SPG433	.1875	.0469	.0313	-	●	●	●
SPG632			.0313		●	●	
SPG633			.0469		●	●	
SPG634			.0625		●	●	

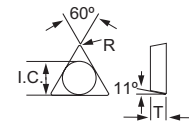
TPG	Cutting Conditions:				Grades		
	Continuous Cut				●	●	●
	Medium Cut				●	●	●
Interrupted Cut				●	●	●	
					SN2000K	SN2100K	NB90S
Catalog #	I.C.	T	r	Hole Dia.			
TPG221	.250	.125	.0156	-	●	●	●
TPG222			.0313		●	●	
TPG321			.0156		●	●	
TPG322	.375	.125	.0313	-	●	●	●
TPG323			.0469		●	●	
TPG332			.0313		●	●	
TPG432	.500	.1875	.0313	-	●	●	●
TPG433			.0469		●	●	

For GROOVING

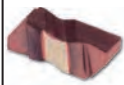
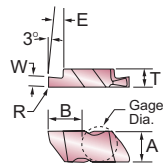
SG	Cutting Conditions:							Grades			
	Continuous Cut							●	●	●	●
	Medium Cut							●	●	●	●
Interrupted Cut							●	●	●	●	
								SN2000K	SN2100K	WX2000	NB90S
Catalog #	W ± .001	R	E ± .001	T	A	B	Gage Dia.				
SG-3047R	.047	.005/.010	.075	.195	.344	.4050	.3750	●	●	●	●
SG-3062R	.062	.005/.010	.094					●	●	●	●
SG-3094R	.094	.005/.010	.150					●	●	●	●
SG-3125R	.125	.005/.010	.150					●	●	●	●

For MILLING

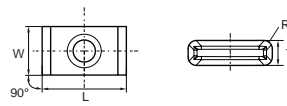
LNGX	Cutting Conditions:				Grades			
	Continuous Cut				●	●	●	●
	Medium Cut				●	●	●	●
Interrupted Cut				●	●	●	●	
					SN2000K	SN2100K	WX2000	NB90S
Catalog #	L	W	T	R				
LNGX160516PNFN-W	.625	.375	.187	.063	●	●	●	●





SUMITOMO

CARBIDE - CBN - DIAMOND

1-800-950-5202

www.sumicarbide.com

PCBN & PCD INSERTS

Pages 157-195



PCBN & PCD
Inserts

PCBN & PCD INSERTS	PAGES
PCBN Inserts	158-182
Threading & Grooving Inserts	181-182
PCD Inserts	182-195

CN

80° Diamond Type

Negative

- K** Cast Iron
- S** Exotic Materials
- H** Hardened Steel
- S_M** Sintered Materials

- USA Stocked Item
- ★ Worldwide Warehouse Item
- ▲ USA Limited Availability Item
- Available 1st Quarter 2017

***EDGE PREPARATIONS:**
See page 579 for descriptions and performance ranges of CBN edge treatments.

PCBN & PCD Inserts

CNMA

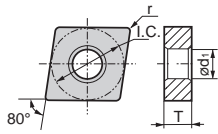

	Catalog No.	ISO Cat. No.	Coated		Uncoated					Dimensions														
			H	K	H	K	S	S _M	Inscribed Circle	Thickness	Nose Radius	Max. D. O. C.	Hole Dia. (ødi)											
			BNC2010	BNC2020	BNC100	BNC160	BNC200	BNC300	BNC500	BNX10	BNX20	BNX25	BN1000	BN2000	BN250	BN350	BN7000	BN700	BNS800	BN7500				
Full Tip	CNMA431	CNMA120404							●											.500	.1875	.0156	.020	.2031
	CNMA432	CNMA120408							●											.500	.1875	.0313	.020	.2031
	CNMA433	CNMA120412							●											.500	.1875	.0469	.020	.2031
Multi-Mid Tip	2MD-CNMA431	2MD-CNMA120404							●											.500	.1875	.0156	.020	.2031
	2MD-CNMA432	2MD-CNMA120408							●											.500	.1875	.0313	.020	.2031
	2MD-CNMA433	2MD-CNMA120412							●											.500	.1875	.0469	.020	.2031
Mini Tip	NS-CNMA431	NS-CNMA120404							●											.500	.1875	.0156	.015	.2031
	NS-CNMA432	NS-CNMA120408							●											.500	.1875	.0313	.015	.2031
	NS-CNMA433	NS-CNMA120412							●											.500	.1875	.0469	.015	.2031
	NU-CNMA430.5	NU-CNMA120402																		.500	.1875	.0078	.015	.2031
	NU-CNMA431	NU-CNMA120404							▲											.500	.1875	.0156	.015	.2031
	NU-CNMA432	NU-CNMA120408							●											.500	.1875	.0313	.015	.2031
	NU-CNMA433	NU-CNMA120412							●											.500	.1875	.0469	.015	.2031

Note: Maximum depth of cut is based on hardened steel applications. Other materials may allow for increased maximum depths of cut.

CNGA

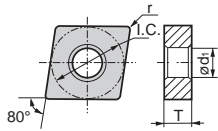

	Catalog No.	ISO Cat. No.	Coated		Uncoated					Dimensions														
			H	K	H	K	S	S _M	Inscribed Circle	Thickness	Nose Radius	Max. D. O. C.	Hole Dia. (ødi)											
			BNC2010	BNC2020	BNC100	BNC160	BNC200	BNC300	BNC500	BNX10	BNX20	BNX25	BN1000	BN2000	BN250	BN350	BN7000	BN700	BNS800	BN7500				
Coated Mini Tip	2NC-CNGA430.5LT*	2NC-CNGA120402LT		★																.500	.1875	.0078	.015	.2031
	2NC-CNGA431LE*	2NC-CNGA120404LE	★																	.500	.1875	.0156	.015	.2031
	2NC-CNGA431LS*	2NC-CNGA120404LS						★												.500	.1875	.0156	.015	.2031
	2NC-CNGA431LT*	2NC-CNGA120404LT		●																.500	.1875	.0156	.015	.2031
	2NC-CNGA432	2NC-CNGA120408	●	●	●	●	●	●												.500	.1875	.0313	.015	.2031
	2NC-CNGA432LE*	2NC-CNGA120408LE	★																	.500	.1875	.0313	.015	.2031
	2NC-CNGA432LS*	2NC-CNGA120408LS			●			★												.500	.1875	.0313	.015	.2031
	2NC-CNGA432LT*	2NC-CNGA120408LT		●																.500	.1875	.0313	.015	.2031
	2NC-CNGA432HS*	2NC-CNGA120408HS	●	●		●	●	●												.500	.1875	.0313	.015	.2031
	2NC-CNGA433	2NC-CNGA120412	●	●	●	●	●	●												.500	.1875	.0469	.015	.2031
	2NC-CNGA433LE*	2NC-CNGA120412	★																	.500	.1875	.0469	.015	.2031
	2NC-CNGA433LS*	2NC-CNGA120412LS			●			★												.500	.1875	.0469	.015	.2031
	2NC-CNGA433LT*	2NC-CNGA120412LT		●																.500	.1875	.0469	.015	.2031
	2NC-CNGA433HS*	2NC-CNGA120412HS	●	●	●	●	●	●												.500	.1875	.0469	.015	.2031
	4NC-CNGA431	4NC-CNGA120404	●	●	●	●	●	★												.500	.1875	.0156	.015	.2031
	4NC-CNGA431ES*	4NC-CNGA120404ES		★																.500	.1875	.0156	.015	.2031
	4NC-CNGA431LS*	4NC-CNGA120404LS			●	●	★													.500	.1875	.0156	.015	.2031
	4NC-CNGA431HS*	4NC-CNGA120404HS	●	●				★												.500	.1875	.0156	.015	.2031
	4NC-CNGA431W*	4NC-CNGA120404W	●	●	●	●	●	●												.500	.1875	.0156	.015	.2031
	4NC-CNGA431WG	4NC-CNGA120404WH	●	●				●												.500	.1875	.0156	.015	.2031
	4NC-CNGA431WH	4NC-CNGA120404WH	●	●	●	●	●	●												.500	.1875	.0156	.015	.2031
	4NC-CNGA432	4NC-CNGA120408	●	●	●	●	●	★												.500	.1875	.0313	.015	.2031
	4NC-CNGA432ES*	4NC-CNGA120408ES		●																.500	.1875	.0313	.015	.2031
	4NC-CNGA432LS*	4NC-CNGA120408LS			●	●	●													.500	.1875	.0313	.015	.2031
	4NC-CNGA432HS*	4NC-CNGA120408HS	●	●	●	●	●	★												.500	.1875	.0313	.015	.2031
	4NC-CNGA432W*	4NC-CNGA120408W	●	●	●	●	●	★												.500	.1875	.0313	.015	.2031
	4NC-CNGA432WG	4NC-CNGA120408WG	●	●				●												.500	.1875	.0313	.015	.2031
	4NC-CNGA432WH	4NC-CNGA120408WH	●	●	●	●	●	●												.500	.1875	.0313	.015	.2031
	4NC-CNGA433	4NC-CNGA120412	●	●	●	●	●	★												.500	.1875	.0469	.015	.2031
	4NC-CNGA433ES	4NC-CNGA120412ES		●																.500	.1875	.0469	.015	.2031
	4NC-CNGA433LS*	4NC-CNGA120412LS			●	●	★													.500	.1875	.0469	.015	.2031
	4NC-CNGA433HS*	4NC-CNGA120412HS	●	●	●	●	●	★												.500	.1875	.0469	.015	.2031



Cubic Boron Nitride (CBN) Inserts

See pages 580 - 581 for running parameters.

PCBN

INSERTS - NEGATIVE

CNGA • CNGG

CN

80° Diamond Type

Negative

- K** Cast Iron
- S** Exotic Materials
- H** Hardened Steel
- S/M** Sintered Materials

- USA Stocked Item
- ★ Worldwide Warehouse Item
- ▲ USA Limited Availability Item
- Available 1st Quarter 2017

***EDGE PREPARATIONS:**

See page 579 for descriptions and performance ranges of CBN edge treatments.

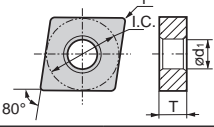
	CNGA (cont.)		Coated														Uncoated								Dimensions				
			H														K				S				Inscribed Circle	Thickness	Nose Radius	Max. D. O. C.	Hole Dia. (ød1)
			BNC2010	BNC2020	BNC100	BNC160	BNC200	BNC300	BNC500	BNX10	BNX20	BNX25	BN1000	BN2000	BN250	BN350	BN7000	BN700	BN5800	BN7500	K	S	S	M					
Multi-Mini Tip	4NC-CNGA433W*	4NC-CNGA120412W	●	●	●	●	●																		.500	.1875	.0469	.015	.2031
	4NC-CNGA433WG	4NC-CNGA120412WG																							.500	.1875	.0469	.015	.2031
	4NC-CNGA433WH	4NC-CNGA120412WH	●	●																					.500	.1875	.0469	.015	.2031
	2NU-CNGA431	2NU-CNGA120404							▲	▲		●	●	●	●	●	●	●	●	●	●	●	●	●	.500	.1875	.0156	.015	.2031
	2NU-CNGA431HS*	2NU-CNGA120404HS										●				●									.500	.1875	.0156	.015	.2031
	2NU-CNGA431F*	2NU-CNGA120404F														●									.500	.1875	.0156	.015	.2031
	2NU-CNGA431T*	2NU-CNGA120404T														★									.500	.1875	.0156	.015	.2031
	2NU-CNGA431W*	2NU-CNGA120404W														●									.500	.1875	.0156	.015	.2031
	2NU-CNGA431WG	2NU-CNGA120404WG														●									.500	.1875	.0156	.015	.2031
	2NU-CNGA431WH	2NU-CNGA120404WH														●									.500	.1875	.0156	.015	.2031
	2NU-CNGA431LE*	2NU-CNGA120404LE														●									.500	.1875	.0156	.015	.2031
	2NU-CNGA431LF*	2NU-CNGA120404LF														●									.500	.1875	.0156	.015	.2031
	2NU-CNGA431LS*	2NU-CNGA120404LS														●									.500	.1875	.0156	.015	.2031
	2NU-CNGA431LT*	2NU-CNGA120404LT														●									.500	.1875	.0156	.015	.2031
	2NU-CNGA432	2NU-CNGA120408								▲						●	●	●	●	●	●	●	●	●	.500	.1875	.0313	.015	.2031
	2NU-CNGA432HS*	2NU-CNGA120408HS														●									.500	.1875	.0313	.015	.2031
	2NU-CNGA432F*	2NU-CNGA120408F														●									.500	.1875	.0313	.015	.2031
	2NU-CNGA432T*	2NU-CNGA120408T														●									.500	.1875	.0313	.015	.2031
	2NU-CNGA432W*	2NU-CNGA120408W														●									.500	.1875	.0313	.015	.2031
	2NU-CNGA432WG	2NU-CNGA120408WG														●									.500	.1875	.0313	.015	.2031
	2NU-CNGA432WH	2NU-CNGA120408WH														●									.500	.1875	.0313	.015	.2031
	2NU-CNGA432LE*	2NU-CNGA120408LE														●									.500	.1875	.0313	.015	.2031
	2NU-CNGA432LF*	2NU-CNGA120408LF														●									.500	.1875	.0313	.015	.2031
	2NU-CNGA432LS*	2NU-CNGA120408LS														●									.500	.1875	.0313	.015	.2031
	2NU-CNGA432LT*	2NU-CNGA120408LT														●									.500	.1875	.0313	.015	.2031
	2NU-CNGA433	2NU-CNGA120412								▲						●	●	●	●	●	●	●	●	●	.500	.1875	.0469	.015	.2031
	2NU-CNGA433HS*	2NU-CNGA120412HS														●									.500	.1875	.0469	.015	.2031
	2NU-CNGA433W*	2NU-CNGA120412W														●									.500	.1875	.0469	.015	.2031
	2NU-CNGA433T*	2NU-CNGA120412T														●									.500	.1875	.0469	.015	.2031
	2NU-CNGA433LT*	2NU-CNGA120412LT														●									.500	.1875	.0469	.015	.2031
Solid	CNGA432	CNGA120408																						.500	.1875	.0313	.150	.2031	
	CNGA433	CNGA120412																						.500	.1875	.0469	.150	.2031	

Note: Maximum depth of cut is based on hardened steel applications. Other materials may allow for increased maximum depths of cut.

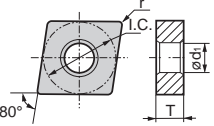
	CNGG		Coated														Uncoated								Dimensions				
			H														K				S				Inscribed Circle	Thickness	Nose Radius	Max. D. O. C.	Hole Dia. (ød1)
			BNC2010	BNC2020	BNC100	BNC160	BNC200	BNC300	BNC500	BNX10	BNX20	BNX25	BN1000	BN2000	BN250	BN350	BN7000	BN700	BN5800	BN7500	K	S	S	M					
Coated Mini	2NU-CNGG431FV	2NC-CNGG120404FV																							.500	.1875	.0156	.015	.2031
	2NU-CNGG431LV	2NC-CNGG120404LV																							.500	.1875	.0156	.015	.2031
	2NU-CNGG432FV	2NC-CNGG120408FV																							.500	.1875	.0313	.015	.2031
	2NU-CNGG432LV	2NC-CNGG120408LV																							.500	.1875	.0313	.015	.2031
	4NC-CNGG431FV	4NC-CNGG120404FV	●	●	●	●	●																		.500	.1875	.0156	.015	.2031
	4NC-CNGG431LV	4NC-CNGG120404LV	●	●	●	●	●																		.500	.1875	.0156	.015	.2031
	4NC-CNGG432FV	4NC-CNGG120408FV	●	●	●	●	●																		.500	.1875	.0313	.015	.2031
	4NC-CNGG432LV	4NC-CNGG120408LV	●	●	●	●	●																		.500	.1875	.0313	.015	.2031
	4NC-CNGG432SV	4NC-CNGG120408SV																							.500	.1875	.0313	.015	.2031
	4NC-CNGG432SVW	4NC-CNGG120408SVW																							.500	.1875	.0313	.015	.2031
	4NC-CNGG433SV	4NC-CNGG120412SV	●																						.500	.1875	.0469	.015	.2031

Note: SV style chipbreaker (see page 262 for more info).



PCBN & PCD Inserts

Cubic Boron Nitride (CBN) Inserts

See pages 580 - 581 for running parameters.

PCBN

INSERTS - NEGATIVE

DNMA • DNGA

DN

55° Diamond Type

Negative

- K** Cast Iron
- S** Exotic Materials
- H** Hardened Steel
- SM** Sintered Materials

- USA Stocked Item
- ★ Worldwide Warehouse Item
- ▲ USA Limited Availability Item
- Available 1st Quarter 2017

***EDGE PREPARATIONS:**

See page 579 for descriptions and performance ranges of CBN edge treatments.

	DNMA	Diagram	Catalog No.		Material													Dimensions												
			Catalog No.	ISO Cat. No.	Coated			Uncoated						S	M	Inscribed Circle	Thickness	Nose Radius	Max. D. O. C.	Hole Dia. (ød1)										
					H	K	H	K	S	M																				
Full Tip		55°	DNMA431	DNMA150404	BNC2010	BNC2020	BNC100	BNC160	BNC200	BNC300	BNC500	BNCX10	BNCX20	BNCX25	BN1000	BN2000	BN250	BN350	BN7000	BN700	BN7500	BN7500	.500	.1875	.0156	.020	.2031			
			DNMA432	DNMA150408																					.500	.1875	.0313	.020	.2031	
			DNMA433	DNMA150412																					.500	.1875	.0469	.020	.2031	
Multi-Min Tip		55°	2MD-DNMA431	2MD-DNMA150404																			.500	.1875	.0156	.020	.2031			
			2MD-DNMA432	2MD-DNMA150408																					.500	.1875	.0313	.020	.2031	
			2MD-DNMA433	2MD-DNMA150412																					.500	.1875	.0469	.020	.2031	
Single Mini Tip		55°	NS-DNMA431	NS-DNMA150404																				.500	.1875	.0156	.015	.2031		
			NS-DNMA432	NS-DNMA150408																					.500	.1875	.0313	.015	.2031	
			NS-DNMA433	NS-DNMA150412																					.500	.1875	.0469	.015	.2031	
			NU-DNMA430	NU-DNMA150401																						.500	.1875	.0039	.015	.2031
			NU-DNMA430.5	NU-DNMA150402																						.500	.1875	.0078	.015	.2031
			NU-DNMA431	NU-DNMA150404																						.500	.1875	.0156	.015	.2031
			NU-DNMA432	NU-DNMA150408																						.500	.1875	.0313	.015	.2031
NU-DNMA433	NU-DNMA150412																						.500	.1875	.0469	.015	.2031			

Note: Maximum depth of cut is based on hardened steel applications. Other materials may allow for increased maximum depths of cut.

	DNGA	Diagram	Catalog No.		Material													Dimensions												
			Catalog No.	ISO Cat. No.	Coated			Uncoated						S	M	Inscribed Circle	Thickness	Nose Radius	Max. D. O. C.	Hole Dia. (ød1)										
					H	K	H	K	S	M																				
Coated Mini Tip		55°	2MD-DNGA432	2MD-DNGA150408	BNC2010	BNC2020	BNC100	BNC160	BNC200	BNC300	BNC500	BNCX10	BNCX20	BNCX25	BN1000	BN2000	BN250	BN350	BN7000	BN700	BN7500	BN7500	.500	.1875	.0313	.020	.2031			
			2NC-DNGA431LE*	2NC-DNGA150404LE	★																				.500	.1875	.0156	.015	.2031	
			2NC-DNGA431LS*	2NC-DNGA150404LS								★														.500	.1875	.0156	.015	.2031
			2NC-DNGA431LT*	2NC-DNGA150404LT																						.500	.1875	.0156	.015	.2031
			2NC-DNGA432	2NC-DNGA150408																						.500	.1875	.0313	.015	.2031
			2NC-DNGA432LE*	2NC-DNGA150408LE	★																					.500	.1875	.0313	.015	.2031
			2NC-DNGA432LS*	2NC-DNGA150408LS																						.500	.1875	.0313	.015	.2031
			2NC-DNGA432LT*	2NC-DNGA150408LT																						.500	.1875	.0313	.015	.2031
			2NC-DNGA432HS*	2NC-DNGA150408HS																						.500	.1875	.0313	.015	.2031
			2NC-DNGA433	2NC-DNGA150412																						.500	.1875	.0469	.015	.2031
			2NC-DNGA433LE*	2NC-DNGA150412LE	★																					.500	.1875	.0469	.015	.2031
			2NC-DNGA433LS*	2NC-DNGA150412LS																						.500	.1875	.0469	.015	.2031
			2NC-DNGA433LT*	2NC-DNGA150412LT																						.500	.1875	.0469	.015	.2031
			2NC-DNGA433HS*	2NC-DNGA150412HS																						.500	.1875	.0469	.015	.2031
			4NC-DNGA431	4NC-DNGA150404																						.500	.1875	.0156	.015	.2031
			4NC-DNGA431ES*	4NC-DNGA150404ES																						.500	.1875	.0156	.015	.2031
			4NC-DNGA431LS*	4NC-DNGA150404LS																						.500	.1875	.0156	.015	.2031
			4NC-DNGA431HS*	4NC-DNGA150404HS																						.500	.1875	.0156	.015	.2031
			4NC-DNGA431WG	4NC-DNGA150404WG																						.500	.1875	.0156	.015	.2031
			4NC-DNGA431WH	4NC-DNGA150404WH																						.500	.1875	.0156	.015	.2031
			4NC-DNGA432	4NC-DNGA150408																						.500	.1875	.0313	.015	.2031
			4NC-DNGA432ES*	4NC-DNGA150408ES																						.500	.1875	.0313	.015	.2031
			4NC-DNGA432LS*	4NC-DNGA150408LS																						.500	.1875	.0313	.015	.2031
			4NC-DNGA432HS*	4NC-DNGA150408HS																						.500	.1875	.0313	.015	.2031
			4NC-DNGA432WG	4NC-DNGA150408WG																						.500	.1875	.0313	.015	.2031
			4NC-DNGA432WH	4NC-DNGA150408WH																						.500	.1875	.0313	.015	.2031
			4NC-DNGA433	4NC-DNGA150412																						.500	.1875	.0469	.015	.2031
			4NC-DNGA433ES*	4NC-DNGA150412ES																						.500	.1875	.0469	.015	.2031
4NC-DNGA433LS*	4NC-DNGA150412LS																						.500	.1875	.0469	.015	.2031			
4NC-DNGA433HS*	4NC-DNGA150412HS																						.500	.1875	.0469	.015	.2031			



DN

55° Diamond Type

Negative

- K** Cast Iron
- S** Exotic Materials
- H** Hardened Steel
- S_M** Sintered Materials

- USA Stocked Item
- ★ Worldwide Warehouse Item
- ▲ USA Limited Availability Item
- Available 1st Quarter 2017

***EDGE PREPARATIONS:**

See page 579 for descriptions and performance ranges of CBN edge treatments.

DNGA

(cont.)

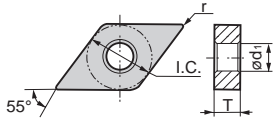

Multi-Mini Tip

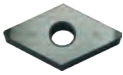

Catalog No.	ISO Cat. No.	Coated		Uncoated					Dimensions								
		H		H		K		S	M	Inscribed Circle	Thickness	Nose Radius	Max. D. O. C.	Hole Dia. (ød1)			
		BNC80	BNC100	BNC150	BNC160	BNC200	BNC300								BNC500	BNCX10	BNCX20
2NU-DNGA431	2NU-DNGA150404										.500	.1875	.0156	.015	.2031		
2NU-DNGA431HS*	2NU-DNGA15040HS										.500	.1875	.0156	.015	.2031		
2NU-DNGA431F*	2NU-DNGA150404F										.500	.1875	.0156	.015	.2031		
2NU-DNGA431T*	2NU-DNGA150404T										.500	.1875	.0156	.015	.2031		
2NU-DNGA431LF*	2NU-DNGA150404LF										.500	.1875	.0156	.015	.2031		
2NU-DNGA431LT*	2NU-DNGA150404LT										.500	.1875	.0156	.015	.2031		
2NU-DNGA431WG	2NU-DNGA150408WG										.500	.1875	.0156	.015	.2031		
2NU-DNGA431WH	2NU-DNGA150404WH										.500	.1875	.0156	.015	.2031		
2NU-DNGA432	2NU-DNGA150408										.500	.1875	.0313	.015	.2031		
2NU-DNGA432HS*	2NU-DNGA150408HS										.500	.1875	.0313	.015	.2031		
2NU-DNGA432F*	2NU-DNGA150408F										.500	.1875	.0313	.015	.2031		
2NU-DNGA432T*	2NU-DNGA150408T										.500	.1875	.0313	.015	.2031		
2NU-DNGA432LF*	2NU-DNGA150408LF										.500	.1875	.0313	.015	.2031		
2NU-DNGA432LT*	2NU-DNGA150408LT										.500	.1875	.0313	.015	.2031		
2NU-DNGA432WG	2NU-DNGA150408WG										.500	.1875	.0313	.015	.2031		
2NU-DNGA432WH	2NU-DNGA150408WH										.500	.1875	.0313	.015	.2031		
2NU-DNGA433	2NU-DNGA150412										.500	.1875	.0469	.015	.2031		
2NU-DNGA433HS*	2NU-DNGA150412HS										.500	.1875	.0469	.015	.2031		
2NU-DNGA433T*	2NU-DNGA150412T										.500	.1875	.0469	.015	.2031		
2NU-DNGA433LT*	2NU-DNGA150412LT										.500	.1875	.0469	.015	.2031		

Note: Maximum depth of cut is based on hardened steel applications. Other materials may allow for increased maximum depths of cut.

DNG

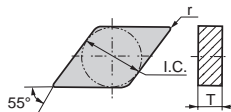

Solid

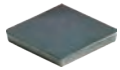

Catalog No.	ISO Cat. No.	Coated		Uncoated					Dimensions								
		H		H		K		S	M	Inscribed Circle	Thickness	Nose Radius	Max. D. O. C.	Hole Dia. (ød1)			
		BNC2010	BNC2020	BNC100	BNC160	BNC200	BNC300								BNC500	BNCX10	BNCX20
DNG322	DNGN110308										.375	.125	.0313	.150	-		
DNG322F	DNGN110308F										.375	.125	.0313	.150	-		
DNG323	DNGN110312										.375	.125	.0469	.150	-		
DNG323F	DNGN110312F										.375	.125	.0469	.150	-		

Note: Maximum depth of cut is based on hardened steel applications. Other materials may allow for increased maximum depths of cut.

DNGG

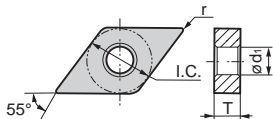

Coated Mini

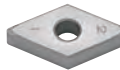

Catalog No.	ISO Cat. No.	Coated		Uncoated					Dimensions								
		H		H		K		S	M	Inscribed Circle	Thickness	Nose Radius	Max. D. O. C.	Hole Dia. (ød1)			
		BNC2010	BNC2020	BNC100	BNC160	BNC200	BNC300								BNC500	BNCX10	BNCX20
2NU-DNGG431FV	2NU-DNGG150404FV										.500	.1875	.0156	.015	.2031		
2NU-DNGG431LV	2NU-DNGG150404LV										.500	.1875	.0156	.015	.2031		
2NU-DNGG432FV	2NU-DNGG150408FV										.500	.1875	.0313	.015	.2031		
2NU-DNGG432LV	2NU-DNGG150408LV										.500	.1875	.0313	.015	.2031		
4NC-DNGG431FV	4NC-DNGG150404FV										.500	.1875	.0156	.015	.2031		
4NC-DNGG431LV	4NC-DNGG150404LV										.500	.1875	.0156	.015	.2031		
4NC-DNGG432FV	4NC-DNGG150408FV										.500	.1875	.0313	.015	.2031		
4NC-DNGG432LV	4NC-DNGG150408LV										.500	.1875	.0313	.015	.2031		
4NC-DNGG432SV	4NC-DNGG150408SV										.500	.1875	.0313	.015	.2031		
4NC-DNGG433SV	4NC-DNGG150412SV										.500	.1875	.0469	.015	.2031		

Note: SV style chipbreaker (see page 262 for more info).



Cubic Boron Nitride (CBN) Inserts

See pages 580 - 581 for running parameters.

PCBN

INSERTS - NEGATIVE

RNG

RN	Round Type
	Negative

- K** Cast Iron
- S** Exotic Materials
- H** Hardened Steel
- S_M** Sintered Materials

- USA Stocked Item
- ★ Worldwide Warehouse Item
- ▲ USA Limited Availability Item
- Available 1st Quarter 2017

***EDGE PREPARATIONS:**

See page 579 for descriptions and performance ranges of CBN edge treatments.

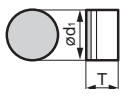
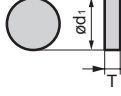
	RNG	Fig. 1 	Fig. 2 	Coated		Uncoated						Dimensions							
				H				K		S		M		Inscribed Circle	Thickness	Nose Radius	Max. D. O. C.	Fig.	
				BNC2010	BNC2020	BNC100	BNC160	BNC200	BNC300	BNC500	BNX10	BNX20	BNX25						BN1000
Full Top		RNG32B RNG43B	RNGN090300B RNGN120400B																
Solid		RNG32 RNG32F RNG42 RNG42F RNG43	RNGN090300 RNGN090300F RNGN120300 RNGN120300F RNGN120400																

Note: Holders available for RNG inserts. Contact the Engineering Department.

PCBN & PCD Inserts



SN

Square Type

Negative

K Cast Iron

S Exotic Materials

H Hardened Steel

S_M Sintered Materials

- USA Stocked Item
- ★ Worldwide Warehouse Item
- ▲ USA Limited Availability Item
- Available 1st Quarter 2017

***EDGE PREPARATIONS:**

See page 579 for descriptions and performance ranges of CBN edge treatments.

PCBN & PCD Inserts

SNMA			Coated		Uncoated						Dimensions									
			H		K	H			K	S	S _M	Inscribed Circle	Thickness	Nose Radius	Max. D. O. C.	Hole Dia. (ød1)				
			BNC2010	BNC2020	BNC100	BNC160	BNC200	BNC300	BNC500	BNX10	BNX20						BNX25	BN1000	BN2000	BN250
Full Tip	SNMA432	SNMA120408														.500	.1875	.0313	.020	.2031
	SNMA433	SNMA120412										★	●				.500	.1875	.0469	.020
Multi-Mid Tip	2MD-SNMA431	2MD-SNMA120404											●			.500	.1875	.0156	.020	.2031
	2MD-SNMA432	2MD-SNMA120408											●			.500	.1875	.0313	.020	.2031
	2MD-SNMA433	2MD-SNMA120412												●		.500	.1875	.0469	.020	.2031
Mini Tip	NU-SNMA431	NU-SNMA120404										●	●			.500	.1875	.0156	.015	.2031
	NU-SNMA432	NU-SNMA120408										●	★	●		.500	.1875	.0313	.015	.2031
	NU-SNMA433	NU-SNMA120412										●	★	●		.500	.1875	.0469	.015	.2031

Note: Maximum depth of cut is based on hardened steel applications. Other materials may allow for increased maximum depths of cut.

SNGA			Coated		Uncoated						Dimensions										
			H		K	H			K	S	S _M	Inscribed Circle	Thickness	Nose Radius	Max. D. O. C.	Hole Dia. (ød1)					
			BNC2010	BNC2020	BNC100	BNC160	BNC200	BNC300	BNC500	BNX10	BNX20						BNX25	BN1000	BN2000	BN250	BN350
Coated Mini Tip	2NC-SNGA432	2NC-SNGA120408		●												.500	.1875	.0313	.015	.2031	
	2NC-SNGA433	2NC-SNGA120412		●												.500	.1875	.0469	.015	.2031	
Multi-Mini Tip	2NU-SNGA431	2NU-SNGA120404											★		●	★	.500	.1875	.0156	.015	.2031
	2NU-SNGA431HS*	2NU-SNGA120404HS													★		.500	.1875	.0156	.015	.2031
	2NU-SNGA431LT*	2NU-SNGA120404LT													★		.500	.1875	.0156	.015	.2031
	2NU-SNGA432	2NU-SNGA120408											★		●	●	.500	.1875	.0313	.015	.2031
	2NU-SNGA432HS*	2NU-SNGA120408HS													★		.500	.1875	.0313	.015	.2031
	2NU-SNGA432LT*	2NU-SNGA120408LT													★		.500	.1875	.0313	.015	.2031
	2NU-SNGA433	2NU-SNGA120412											●	●	●	●	.500	.1875	.0469	.015	.2031
	2NU-SNGA433HS*	2NU-SNGA120412HS													★		.500	.1875	.0469	.015	.2031
	2NU-SNGA433T*	2NU-SNGA120412T														●	.500	.1875	.0469	.015	.2031
2NU-SNGA433LT*	2NU-SNGA120412LT													★		.500	.1875	.0469	.015	.2031	
Solid	SNGA432	SNGA120408															.500	.1875	.0313	.150	.2031
	SNGA433	SNGA120412															.500	.1875	.0469	.150	.2031

Note: Maximum depth of cut is based on hardened steel applications. Other materials may allow for increased maximum depths of cut.



Cubic Boron Nitride (CBN) Inserts

See pages 580 - 581 for running parameters.

PCBN

INSERTS - NEGATIVE

SNGX • SNG

SN

Square Type

Negative

- K Cast Iron
- S Exotic Materials
- H Hardened Steel
- S_M Sintered Materials

- USA Stocked Item
- ★ Worldwide Warehouse Item
- ▲ USA Limited Availability Item
- Available 1st Quarter 2017

***EDGE PREPARATIONS:**
See page 579 for descriptions and performance ranges of CBN edge treatments.

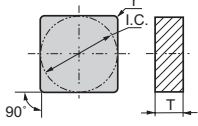
Solid CBN	SNGX		Coated										Uncoated				Dimensions					
			H					K	H					K	S	S _M	Inscribed Circle	Thickness	Nose Radius	Max. D. O. C.	Hole Dia. (ød1)	
			BNC2010	BNC2020	BNC100	BNC160	BNC200	BNC300	BNC500	BNX10	BNX20	BNX25	BN1000	BN2000	BN250	BN350						BN7000
	SNGX433	SNGX120412															●	.500	.1875	.0469	.150	-
	SNGX434	SNGX120416															●	.500	.1875	.0625	.150	-

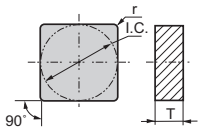
Solid	SNG		Coated										Uncoated				Dimensions					
			H					K	H					K	S	S _M	Inscribed Circle	Thickness	Nose Radius	Max. D. O. C.	Hole Dia. (ød1)	
			BNC2010	BNC2020	BNC100	BNC160	BNC200	BNC300	BNC500	BNX10	BNX20	BNX25	BN1000	BN2000	BN250	BN350						BN7000
	SNG322	SNGN090308															●	.375	.125	.0313	.150	-
	SNG322F*	SNGN090308F															★	.375	.125	.0313	.150	-
	SNG323	SNGN090312															●	.375	.125	.0469	.150	-
	SNG323F*	SNGN090312F															★	.375	.125	.0469	.150	-
	SNG422	SNGN120308															●	.500	.125	.0313	.150	-
	SNG422F*	SNGN120308F															★	.500	.125	.0313	.150	-
	SNG423	SNGN120312															●	.500	.125	.0469	.150	-
	SNG423F*	SNGN120312F															★	.500	.125	.0469	.150	-
	SNG424	SNGN120316															●	.500	.125	.0625	.150	-
	SNG432	SNGN120408								★		★					●	.500	.1875	.0313	.150	-
	SNG433	SNGN120412										★					●	.500	.1875	.0469	.150	-
	SNG434	SNGN120416															●	.500	.1875	.0625	.150	-



TN

60° Triangle Type

Negative

- K** Cast Iron
- S** Exotic Materials
- H** Hardened Steel
- S_M** Sintered Materials

- USA Stocked Item
- ★ Worldwide Warehouse Item
- ▲ USA Limited Availability Item
- Available 1st Quarter 2017

***EDGE PREPARATIONS:**

See page 579 for descriptions and performance ranges of CBN edge treatments.

TNMA

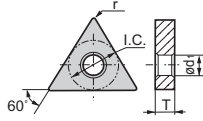

	Catalog No.	ISO Cat. No.	Coated		Uncoated							Dimensions									
			H		K		H			K		S		Inscribed Circle	Thickness	Nose Radius	Max. D. O. C.	Hole Dia. (ød1)			
			BNC2010	BNC2020	BNC100	BNC160	BNC200	BNC300	BNC500	BNX10	BNX20	BNX25	BN1000						BN2000	BN250	BN350
Full Tip	TNMA330.5	TNMA160402															.375	.1875	.0078	.020	.150
	TNMA331	TNMA160404															.375	.1875	.0156	.020	.150
	TNMA332	TNMA160408															.375	.1875	.0313	.020	.150
	TNMA333	TNMA160412															.375	.1875	.0469	.020	.150
	TNMA431	TNMA220404															.500	.1875	.0156	.020	.2031
	TNMA432	TNMA220408															.500	.1875	.0313	.020	.2031
	TNMA433	TNMA220412															.500	.1875	.0469	.020	.2031
Multi-Mid Tip	3MD-TNMA331	3MD-TNMA160404															.375	.1875	.0156	.020	.150
	3MD-TNMA332	3MD-TNMA160408															.375	.1875	.0313	.020	.150
Mini Tip	NS-TNMA331	NS-TNMA160404															.375	.1875	.0156	.015	.150
	NS-TNMA332	NS-TNMA160408															.375	.1875	.0313	.015	.150
	NU-TNMA330	NU-TNMA160401															.375	.1875	.0039	.015	.150
	NU-TNMA330.5	NU-TNMA160402															.375	.1875	.0078	.015	.150
	NU-TNMA331	NU-TNMA160404															.375	.1875	.0156	.015	.150
	NU-TNMA332	NU-TNMA160408															.375	.1875	.0313	.015	.150
	NU-TNMA333	NU-TNMA160412															.375	.1875	.0469	.015	.150
	NU-TNMA431	NU-TNMA220404															.500	.1875	.0156	.015	.2031
	NU-TNMA432	NU-TNMA220408															.500	.1875	.0313	.015	.2031
	NU-TNMA433	NU-TNMA150412															.500	.1875	.0469	.015	.2031

Note: Maximum depth of cut is based on hardened steel applications. Other materials may allow for increased maximum depths of cut.



Cubic Boron Nitride (CBN) Inserts

See pages 580 - 581 for running parameters.

PCBN

INSERTS - NEGATIVE

TNGA

TN

60° Triangle Type

Negative

- K** Cast Iron
- S** Exotic Materials
- H** Hardened Steel
- S_M** Sintered Materials

- USA Stocked Item
- ★ Worldwide Warehouse Item
- ▲ USA Limited Availability Item
- Available 1st Quarter 2017

***EDGE PREPARATIONS:**

See page 579 for descriptions and performance ranges of CBN edge treatments.

TNGA	Catalog No.	ISO Cat. No.	Coated													Uncoated					Dimensions								
			H													H					Inscribed Circle	Thickness	Nose Radius	Max. D. O. C.	Hole Dia. (ød1)				
			BNC2010	BNC2020	BNC100	BNC160	BNC200	BNC300	BNC500	BNX10	BNX20	BNX25	BN1000	BN2000	BN250	BN350	BN7000	BN700	BN5800	BN7500						K	S	S _M	
Coated Mini-Tip	3NC-TNGA330.5LT*	3NC-TNGA160402LT	★																					.375	.1875	.0078	.015	.150	
	3NC-TNGA331LE*	3NC-TNGA160404LE	★																						.375	.1875	.0156	.015	.150
	3NC-TNGA331LS*	3NC-TNGA160404LS																							.375	.1875	.0156	.015	.150
	3NC-TNGA331LT*	3NC-TNGA160404LT																							.375	.1875	.0156	.015	.150
	3NC-TNGA332	3NC-TNGA160408	●	●	●	●	●	●																	.375	.1875	.0313	.015	.150
	3NC-TNGA332LE*	3NC-TNGA160408LE	★																						.375	.1875	.0313	.015	.150
	3NC-TNGA332LS*	3NC-TNGA160408LS				●																			.375	.1875	.0313	.015	.150
	3NC-TNGA332LT*	3NC-TNGA160408LT				●																			.375	.1875	.0313	.015	.150
	3NC-TNGA332HS*	3NC-TNGA160408HS				●																			.375	.1875	.0313	.015	.150
	3NC-TNGA333LE*	3NC-TNGA160412LE																							.375	.1875	.0469	.015	.150
	3NC-TNGA333LT*	3NC-TNGA160412LT																							.375	.1875	.0469	.015	.150
	6NC-TNGA331	6NC-TNGA160404	●	●	●	●	●	●	★																.375	.1875	.0156	.015	.150
	6NC-TNGA331ES*	6NC-TNGA160404ES		★																					.375	.1875	.0156	.015	.150
	6NC-TNGA331LS*	6NC-TNGA160404LS					●	★																	.375	.1875	.0156	.015	.150
	6NC-TNGA331HS*	6NC-TNGA160404HS	●	●	●	●	●	★																	.375	.1875	.0156	.015	.150
	6NC-TNGA332	6NC-TNGA160408	●	●	●	●	●	★																	.375	.1875	.0313	.015	.150
	6NC-TNGA332ES*	6NC-TNGA160408ES		★																					.375	.1875	.0313	.015	.150
	6NC-TNGA332LS*	6NC-TNGA160408LS				●	●	★																	.375	.1875	.0313	.015	.150
	6NC-TNGA332HS*	6NC-TNGA160408HS	●	●	●	●	●	★																	.375	.1875	.0313	.015	.150
	6NC-TNGA333	6NC-TNGA160412	●	●	●	●	●	★																	.375	.1875	.0469	.015	.150
6NC-TNGA333ES*	6NC-TNGA160412ES		★																					.375	.1875	.0469	.015	.150	
6NC-TNGA333LS*	6NC-TNGA160412LS				●		★	★																.375	.1875	.0469	.015	.150	
6NC-TNGA333HS*	6NC-TNGA160412HS	●	●	●	●	●	★																	.375	.1875	.0469	.015	.150	
Multi-Mini Tip	3NU-TNGA331	3NU-TNGA160404								★	●	●	●	●	●	●	●	●	●	●	●	●	●	.375	.1875	.0156	.015	.150	
	3NU-TNGA331LS*	3NU-TNGA160404LS																					●	.375	.1875	.0156	.015	.150	
	3NU-TNGA331HS*	3NU-TNGA160404HS										●											●	.375	.1875	.0156	.015	.150	
	3NU-TNGA331T*	3NU-TNGA160404T																					★	.375	.1875	.0156	.015	.150	
	3NU-TNGA331LE*	3NU-TNGA160404LE																					●	.375	.1875	.0156	.015	.150	
	3NU-TNGA331LF*	3NU-TNGA160404LF																					●	.375	.1875	.0156	.015	.150	
	3NU-TNGA331LT*	3NU-TNGA160404LT																					●	.375	.1875	.0156	.015	.150	
	3NU-TNGA332	3NU-TNGA160408								★	●	●	●	●	●	●	●	●	●	●	●	●	●	●	.375	.1875	.0313	.015	.150
	3NU-TNGA332LS*	3NU-TNGA160408LS																					●	.375	.1875	.0313	.015	.150	
	3NU-TNGA332HS*	3NU-TNGA160408HS										●											●	.375	.1875	.0313	.015	.150	
	3NU-TNGA332T*	3NU-TNGA160408T																					●	.375	.1875	.0313	.015	.150	
	3NU-TNGA332LE*	3NU-TNGA160408LE																					●	.375	.1875	.0313	.015	.150	
	3NU-TNGA332LF*	3NU-TNGA160408LF																					●	.375	.1875	.0313	.015	.150	
	3NU-TNGA332LT*	3NU-TNGA160408LT										●	●										●	.375	.1875	.0313	.015	.150	
	3NU-TNGA333	3NU-TNGA160412								★	●	●	●	●	●	●	●	●	●	●	●	●	●	●	.375	.1875	.0469	.015	.150
3NU-TNGA333HS*	3NU-TNGA160412HS										●											●	.375	.1875	.0469	.015	.150		
3NU-TNGA333LT*	3NU-TNGA160412LT										●	●										●	.375	.1875	.0469	.015	.150		
Solid CBN	TNGA332	TNGA160408																					★	.375	.1875	.0313	.150	.150	
	TNGA333	TNGA160412																					★	.375	.1875	.0469	.150	.150	

PCBN & PCD Inserts



TN

60° Triangle Type

Negative

- K Cast Iron
- S Exotic Materials
- H Hardened Steel
- S_M Sintered Materials

- USA Stocked Item
- ★ Worldwide Warehouse Item
- ▲ USA Limited Availability Item
- Available 1st Quarter 2017

***EDGE PREPARATIONS:**
See page 579 for descriptions and performance ranges of CBN edge treatments.

	TNG	Diagram	Catalog No.		Coated										Uncoated					Dimensions				
			ISO Cat. No.	H	K	H					K	S	S _M	Inscribed Circle	Thickness	Nose Radius	Max. D. O. C.	Hole Dia. (ød1)						
						BNC2010	BNC2020	BNC100	BNC160	BNC200									BNC300	BNC500	BNX10	BNX20	BNX25	BN1000
Full Tip	TNG331	TNGN160408																	.375	.1875	.0156	.150	-	
	TNG332	TNGN160408																	.375	.1875	.0313	.150	-	
	TNG333	TNGN160412																	.375	.1875	.0469	.150	-	
Solid CBN	TNG222	TNGN110308																	●	.250	.125	.0313	.150	-
	TNG222F*	TNGN110308F																	★	.250	.125	.0313	.150	-
	TNG223	TNGN110312																	★	.250	.125	.0469	.150	-
	TNG223F*	TNGN110312F																	★	.250	.125	.0469	.150	-
	TNG333	TNGN160412																	●	.375	.1875	.0469	.150	-
	TNG334	TNGN160416																	★	.375	.1875	.0625	.150	-

VN

35° Diamond Type

Negative

	VNMA	Diagram	Catalog No.		Coated										Uncoated					Dimensions				
			ISO Cat. No.	H	K	H					K	S	S _M	Inscribed Circle	Thickness	Nose Radius	Max. D. O. C.	Hole Dia. (ød1)						
						BNC2010	BNC2020	BNC100	BNC160	BNC200									BNC300	BNC500	BNX10	BNX20	BNX25	BN1000
Full Tip	VNMA331	VNMA160404																		.375	.1875	.0156	.020	.150
	VNMA332	VNMA160408																		.375	.1875	.0313	.020	.150
Multi-Mid Tip	2MD-VNMA331	2MD-VNMA160404																		.375	.1875	.0156	.020	.150
	2MD-VNMA332	2MD-VNMA160408																		.375	.1875	.0313	.020	.150
	2MD-VNMA333	2MD-VNMA160412																		.375	.1875	.0469	.020	.150
Mini Tip	NS-VNMA331	NS-VNMA160404																		.375	.1875	.0156	.015	.150
	NS-VNMA332	NS-VNMA160408																		.375	.1875	.0313	.015	.150
	NU-VNMA330	NU-VNMA160401																		.375	.1875	.0039	.015	.150
	NU-VNMA330.5	NU-VNMA160402																		.375	.1875	.0078	.015	.150
	NU-VNMA331	NU-VNMA160404																		.375	.1875	.0156	.015	.150
	NU-VNMA332	NU-VNMA160408																		.375	.1875	.0313	.015	.150
	NU-VNMA333	NU-VNMA160412																		.375	.1875	.0469	.015	.150

Note: Maximum depth of cut is based on hardened steel applications. Other materials may allow for increased maximum depths of cut.



Cubic Boron Nitride (PCBN) Inserts

See pages 580 - 581 for running parameters.

PCBN

INSERTS - NEGATIVE

VNGA

VN

35° Diamond Type

Negative

- K** Cast Iron
- S** Exotic Materials
- H** Hardened Steel
- SiM** Sintered Materials

- USA Stocked Item
- ★ Worldwide Warehouse Item
- ▲ USA Limited Availability Item
- Available 1st Quarter 2017

***EDGE PREPARATIONS:**

See page 579 for descriptions and performance ranges of CBN edge treatments.

VNGA

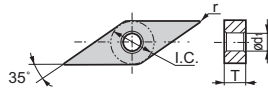

Coated Mini Tip

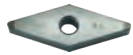
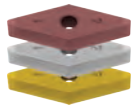

Multi-Mini Tip

Catalog No.	ISO Cat. No.	Coated					Uncoated					Dimensions											
		BNC2010	BNC2020	BNC100	BNC160	BNC200	BNC300	BNC500	BNX10	BNX20	BNX25	BN1000	BN2000	BN250	BN350	BN7000	BN700	BN5800	BN7500	Inscribed Circle	Thickness	Nose Radius	Max. D. O. C.
2NC-VNGA330.5LT	2NC-VNGA160402LT	★																	.375	.1875	.0078	.015	.150
2NC-VNGA331LT	2NC-VNGA160404LT	●																	.375	.1875	.0156	.015	.150
2NC-VNGA332	2NC-VNGA160408	●	●	●	●	●													.375	.1875	.0313	.015	.150
2NC-VNGA332LS*	2NC-VNGA160408LS					●													.375	.1875	.0313	.015	.150
2NC-VNGA332LT*	2NC-VNGA160408LT	●																	.375	.1875	.0313	.015	.150
2NC-VNGA332HS*	2NC-VNGA160408HS	●				●	●												.375	.1875	.0313	.015	.150
2NC-VNGA333LT*	2NC-VNGA160412LT	★																	.375	.1875	.0469	.015	.150
4NC-VNGA331	4NC-VNGA160404	●	●	●	●	●	★												.375	.1875	.0156	.015	.150
4NC-VNGA331ES*	4NC-VNGA160404ES		●																.375	.1875	.0156	.015	.150
4NC-VNGA331LS*	4NC-VNGA160404LS			●	●	●													.375	.1875	.0156	.015	.150
4NC-VNGA331HS*	4NC-VNGA160404HS	●	●	●	●	●	★												.375	.1875	.0156	.015	.150
4NC-VNGA332	4NC-VNGA160408	●	●	●	●	●	★												.375	.1875	.0313	.015	.150
4NC-VNGA332ES*	4NC-VNGA160408ES		●																.375	.1875	.0313	.015	.150
4NC-VNGA332LS*	4NC-VNGA160408LS			●	●	●													.375	.1875	.0313	.015	.150
4NC-VNGA332HS*	4NC-VNGA160408HS	●	●	●	●	●	★												.375	.1875	.0313	.015	.150
4NC-VNGA333	4NC-VNGA160412	●				●													.375	.1875	.0469	.015	.150
4NC-VNGA333ES*	4NC-VNGA160412ES	★																	.375	.1875	.0469	.015	.150
2NU-VNGA331	2NU-VNGA160404							★	●	●	●	●	●	●	●	●	●	●	.375	.1875	.0156	.015	.150
2NU-VNGA331HS*	2NU-VNGA160404HS								●	●	●	●	●	●	●	●	●	●	.375	.1875	.0156	.015	.150
2NU-VNGA331LT*	2NU-VNGA160404LT								●	●	●	●	●	●	●	●	●	●	.375	.1875	.0156	.015	.150
2NU-VNGA332	2NU-VNGA160408							●	●	●	●	●	●	●	●	●	●	●	.375	.1875	.0313	.015	.150
2NU-VNGA332HS*	2NU-VNGA160408HS								●	●	●	●	●	●	●	●	●	●	.375	.1875	.0313	.015	.150
2NU-VNGA332F*	2NU-VNGA160408F														●	●	●	●	.375	.1875	.0313	.015	.150
2NU-VNGA332T*	2NU-VNGA160408T														●	●	●	●	.375	.1875	.0313	.015	.150
2NU-VNGA332LF*	2NU-VNGA160408LF														●	●	●	●	.375	.1875	.0313	.015	.150
2NU-VNGA332LT*	2NU-VNGA160408LT								●	●	●	●	●	●	●	●	●	●	.375	.1875	.0313	.015	.150
2NU-VNGA333	2NU-VNGA160412														●	●	●	●	.375	.1875	.0469	.015	.150

Note: Maximum depth of cut is based on hardened steel applications. Other materials may allow for increased maximum depths of cut.



WN

80° Trigon Type

Negative

- K Cast Iron
- S Exotic Materials
- H Hardened Steel
- S_M Sintered Materials

- USA Stocked Item
- ★ Worldwide Warehouse Item
- ▲ USA Limited Availability Item
- Available 1st Quarter 2017

***EDGE PREPARATIONS:**
See page 579 for descriptions and performance ranges of CBN edge treatments.

PCBN & PCD Inserts

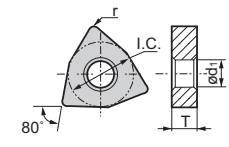
Mini Tip	WNMA		Coated		Uncoated						Dimensions														
			H		K	H			K		S	Inscribed Circle	Thickness	Nose Radius	Max. D. O. C.	Hole Dia. (ød1)									
			BNC2010	BNC2020	BNC100	BNC160	BNC200	BNC300	BNC500	BNX10	BNX20						BNX25	BN1000	BN2000	BN250	BN350	BN7000	BN700	BN5800	BN7500
	Catalog No.	ISO Cat. No.																							
	NU-WNMA431	NU-WNMA080404									●	●	●	●							.500	.1875	.0156	.015	.2031
	NU-WNMA432	NU-WNMA080408									●	●	●	●							.500	.1875	.0313	.015	.2031
	NU-WNMA433	NU-WNMA080412												●							.500	.1875	.0469	.015	.2031

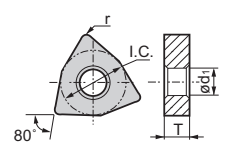
Coated Mini Tip	WNGA		Coated		Uncoated						Dimensions															
			H		K	H			K		S	Inscribed Circle	Thickness	Nose Radius	Max. D. O. C.	Hole Dia. (ød1)										
			BNC2010	BNC2020	BNC100	BNC160	BNC200	BNC300	BNC500	BNX10	BNX20						BNX25	BN1000	BN2000	BN250	BN350	BN7000	BN700	BN5800	BN7500	
	Catalog No.	ISO Cat. No.																								
	3NC-WNGA432LT	3NC-WNGA080408LT		★																		.500	.1875	.0313	.015	.2031
	6NC-WNGA432	6NC-WNGA080408	●	●	●	●																.500	.1875	.0313	.015	.2031
	6NC-WNGA432LS	6NC-WNGA080408LS																				.500	.1875	.0313	.015	.2031
	6NC-WNGA432HS	6NC-WNGA080408HS		●			★															.500	.1875	.0313	.015	.2031
	6NC-WNGA432WG	6NC-WNGA080408WG	●	●		●	●															.500	.1875	.0313	.015	.2031
	6NC-WNGA432WH	6NC-WNGA080408WH	●	●		●	●															.500	.1875	.0313	.015	.2031
	6NC-WNGA433WG	6NC-WNGA080412WG	●	●		●	●															.500	.1875	.0469	.015	.2031
	6NC-WNGA433WH	6NC-WNGA080412WH	●	●		●	●															.500	.1875	.0469	.015	.2031
	3NU-WNGA432	3NU-WNGA080408									●			●	●							.500	.1875	.0313	.015	.2031
	3NU-WNGA433	3NU-WNGA080412												●	●							.500	.1875	.0469	.015	.2031

Note: Maximum depth of cut is based on hardened steel applications. Other materials may allow for increased maximum depths of cut.



CC

80° Diamond Type

7° Relief

- K** Cast Iron
- S** Exotic Materials
- H** Hardened Steel
- S_M** Sintered Materials

- USA Stocked Item
- ★ Worldwide Warehouse Item
- ▲ USA Limited Availability Item
- Available 1st Quarter 2017

***EDGE PREPARATIONS:**

See page 579 for descriptions and performance ranges of CBN edge treatments.

PCBN & PCD Inserts

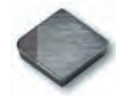
			Coated		Uncoated							Dimensions															
			H	K	H				K		S	M	Inscribed Circle	Thickness	Nose Radius	Max. D. O. C.	Hole Diameter										
			BNC2010	BNC2020	BNC100	BNC160	BNC200	BNC300	BNC500	BNX10	BNX20	BNX25	BN1000	BN2000	BN250	BN350	BN7000	BN700	BN5800	BN7500							
Mini Tip		Catalog No.	NU-CCGE621	NU-CCGW040104																	.1875	.062	.0156	.015	-		
		ISO Cat. No.	NU-CCGE621HS*	NU-CCGW040104HS																		.1875	.062	.0156	.015	-	
			NU-CCGE622	NU-CCGW040108																			.1875	.062	.0313	.015	-
			NU-CCGE622HS*	NU-CCGW040108HS																			.1875	.062	.0313	.015	-

Note: Maximum depth of cut is based on hardened steel applications. Other materials may allow for increased maximum depths of cut.

CP

80° Diamond Type

11° Relief

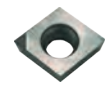
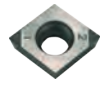
			Coated		Uncoated							Dimensions															
			H	K	H				K		S	M	Inscribed Circle	Thickness	Nose Radius	Max. D. O. C.	Hole Dia. (ødt)										
			BNC2010	BNC2020	BNC100	BNC160	BNC200	BNC300	BNC500	BNX10	BNX20	BNX25	BN1000	BN2000	BN250	BN350	BN7000	BN700	BN5800	BN7500							
Mini Tip		Catalog No.	NU-CPGA2.51.50.5	NU-CPGW080202																	.3125	.094	.0078	.015	.134		
		ISO Cat. No.	NU-CPGA2.51.50.5HS*	NU-CPGW080202HS																		.3125	.094	.0078	.015	.134	
			NU-CPGA2.51.51	NU-CPGW080204																			.3125	.094	.0156	.015	.134
			NU-CPGA2.51.51HS*	NU-CPGW080204HS																			.3125	.094	.0156	.015	.134
			NU-CPGA2.51.51LT*	NU-CPGW080204LT																			.3125	.094	.0156	.015	.134
			NU-CPGA2.51.52	NU-CPGW080208																			.3125	.094	.0313	.015	.134
			NU-CPGA2.51.52HS*	NU-CPGW080208HS																			.3125	.094	.0313	.015	.134
			NU-CPGA320.5	NU-CPGW090302																			.375	.125	.0078	.015	.1732
			NU-CPGA320.5HS*	NU-CPGW090302HS																			.375	.125	.0078	.015	.1732
			NU-CPGA320.5LT*	NU-CPGW090302LT																			.375	.125	.0078	.015	.1732
			NU-CPGA321	NU-CPGW090304																			.375	.125	.0156	.015	.1732
			NU-CPGA321HS*	NU-CPGW090304HS																			.375	.125	.0156	.015	.1732
			NU-CPGA321LT*	NU-CPGW090304LT																			.375	.125	.0156	.015	.1732
			NU-CPGA322	NU-CPGW090308																			.375	.125	.0313	.015	.1732
Multi-Mini Tip		Catalog No.	NU-CPGA322HS*	NU-CPGW090308HS																	.375	.125	.0313	.015	.1732		
		ISO Cat. No.	NU-CPGA322LT*	NU-CPGW090308LT																		.375	.125	.0313	.015	.1732	
			2NU-CPGA32.51	2NU-CPGW09T304																		.375	.156	.0156	.015	.1732	
	2NU-CPGA32.52	2NU-CPGW09T308																			.375	.156	.0313	.015	.1732		

Note: Maximum depth of cut is based on hardened steel applications. Other materials may allow for increased maximum depths of cut.



Cubic Boron Nitride (PCBN) Inserts

See pages 580 - 581 for running parameters.

PCBN

INSERTS - POSITIVE

DCGA • DCGD

DC

55° Diamond Type

7° Relief

- K Cast Iron
- S Exotic Materials
- H Hardened Steel
- S/M Sintered Materials

- USA Stocked Item
- ★ Worldwide Warehouse Item
- ▲ USA Limited Availability Item
- Available 1st Quarter 2017

*EDGE PREPARATIONS:

See page 579 for descriptions and performance ranges of CBN edge treatments.

DCGA DCGD

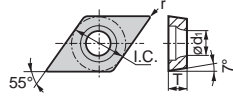

Catalog No. ISO Cat. No.

	Coated	Coated		Uncoated											Dimensions								
		H		K	H		K		S		S		Inscribed Circle	Thickness	Nose Radius	Max. D. O. C.	Hole Dia. (øD1)						
		BNC2010	BNC2020	BNC100	BNC160	BNC200	BNC300	BNC500	BNX10	BNX20	BNX25	BN2000						BN250	BN350	BN7000	BN700	BN800	BN7500
2NC-DCGA21.50.5	2NC-DCGW070202	●	●	●	●														.250	.094	.0078	.015	.110
2NC-DCGA21.50.5LT*	2NC-DCGW070202LT	●	●	●	●														.250	.094	.0078	.015	.110
2NC-DCGA21.50.5WG	2NC-DCGW070202WG	●	●	●	●														.250	.094	.0078	.015	.110
2NC-DCGA21.51	2NC-DCGW070204	●	●	●	●														.250	.094	.0156	.015	.110
2NC-DCGA21.51LS*	2NC-DCGW070204LS	●	●	●	●														.250	.094	.0156	.015	.110
2NC-DCGA21.51LT*	2NC-DCGW070204LT	●	●	●	●														.250	.094	.0156	.015	.110
2NC-DCGA21.51WG	2NC-DCGW070204WG	●	●	●	●														.250	.094	.0156	.015	.110
2NC-DCGA21.52WG	2NC-DCGW070208WG	●	●	●	●														.250	.094	.0313	.015	.110
2NC-DCGA32.50.5	2NC-DCGW11T302	●	●	●	●														.375	.156	.0078	.015	.1732
2NC-DCGA32.50.5LE*	2NC-DCGW11T302LE	★																	.375	.156	.0078	.015	.1732
2NC-DCGA32.50.5LT*	2NC-DCGW11T302LT		★																.375	.156	.0078	.015	.1732
2NC-DCGA32.50.5WG	2NC-DCGW11T302WG	●	●	●	●														.375	.156	.0078	.015	.1732
2NC-DCGA32.51	2NC-DCGW11T304	●	●	●	●														.375	.156	.0156	.015	.1732
2NC-DCGA32.51LE*	2NC-DCGW11T304LE	★																	.375	.156	.0156	.015	.1732
2NC-DCGA32.51LS*	2NC-DCGW11T304LS		●			★													.375	.156	.0156	.015	.1732
2NC-DCGA32.51LT*	2NC-DCGW11T304LT		●			★													.375	.156	.0156	.015	.1732
2NC-DCGA32.51WG	2NC-DCGW11T304WG	●	●	●	●														.375	.156	.0156	.015	.1732
2NC-DCGA32.52	2NC-DCGW11T308	●	●	●	●														.375	.156	.0313	.015	.1732
2NC-DCGA32.52LE*	2NC-DCGW11T308LE	★																	.375	.156	.0313	.015	.1732
2NC-DCGA32.52LS*	2NC-DCGW11T308LS		●			★													.375	.156	.0313	.015	.1732
2NC-DCGA32.52LT*	2NC-DCGW11T308LT		●			★													.375	.156	.0313	.015	.1732
2NC-DCGA32.52WG	2NC-DCGW11T308WG	●	●	●	●														.375	.156	.0313	.015	.1732
NU-DCGD21.50.5	NU-DCGW070202																		.250	.094	.0078	.015	.110
NU-DCGD21.51	NU-DCGW070204																		.250	.094	.0156	.015	.110
NU-DCGA21.50.5	NU-DCGW070202									●	●								.250	.094	.0078	.015	.110
NU-DCGA21.50.5HS*	NU-DCGW070202HS									●	●								.250	.094	.0078	.015	.110
NU-DCGA21.50.5LT*	NU-DCGW070202LT									●	●								.250	.094	.0078	.015	.110
NU-DCGA21.51	NU-DCGW070204									●	●								.250	.094	.0156	.015	.110
NU-DCGA21.51HS*	NU-DCGW070204HS									●	●								.250	.094	.0156	.015	.110
NU-DCGA21.51LT*	NU-DCGW070204LT									●	●								.250	.094	.0156	.015	.110
NU-DCGA21.52	NU-DCGW070208									●	●								.250	.094	.0313	.015	.110
NU-DCGA21.52LT*	NU-DCGW070208LT									●	●								.250	.094	.0313	.015	.110
NU-DCGA32.50.5	NU-DCGW11T302									●	●								.375	.156	.0078	.015	.1732
NU-DCGA32.50.5HS*	NU-DCGW11T302HS									●	●								.375	.156	.0078	.015	.1732
NU-DCGA32.50.5LT*	NU-DCGW11T302LT									●	●								.375	.156	.0078	.015	.1732
NU-DCGA32.51	NU-DCGW11T304									●	●								.375	.156	.0156	.015	.1732
NU-DCGA32.51HS*	NU-DCGW11T304HS									●	●								.375	.156	.0156	.015	.1732
NU-DCGA32.51LT*	NU-DCGW11T304LT									●	●								.375	.156	.0156	.015	.1732
NU-DCGA32.52	NU-DCGW11T308									●	●								.375	.156	.0313	.015	.1732
NU-DCGA32.52LS*	NU-DCGW11T308LS									●	●								.375	.156	.0313	.015	.1732
NU-DCGA32.52LE*	NU-DCGW11T308LE									●	●								.375	.156	.0313	.015	.1732
NU-DCGA32.53	NU-DCGW11T312									●	●								.375	.156	.0469	.015	.1732
NU-DCGA32.53LT*	NU-DCGW11T312LT									●	●								.375	.156	.0469	.015	.1732
2NU-DCGA21.50.5	2NU-DCGW070202																		.250	.094	.0078	.015	.110
2NU-DCGA21.50.5WG	2NU-DCGW070202WG																		.250	.094	.0078	.015	.110
2NU-DCGA21.51	2NU-DCGW070204										●	●							.250	.094	.0156	.015	.110
2NU-DCGA21.51W	2NU-DCGW070204W											●	●						.250	.094	.0156	.015	.110
2NU-DCGA21.51WG	2NU-DCGW070204WG												●	●					.250	.094	.0156	.015	.110
2NU-DCGA21.52	2NU-DCGW070208																		.250	.094	.0313	.015	.110
2NU-DCGA21.52WG	2NU-DCGW070208WG																		.250	.094	.0313	.015	.110
2NU-DCGA32.50.5	2NU-DCGW11T302																		.375	.156	.0078	.015	.1732
2NU-DCGA32.50.5LS*	2NU-DCGW11T302LS																		.375	.156	.0078	.015	.1732
2NU-DCGA32.50.5LE*	2NU-DCGW11T302LE																		.375	.156	.0078	.015	.1732
2NU-DCGA32.50.5LF*	2NU-DCGW11T302LF																		.375	.156	.0078	.015	.1732
2NU-DCGA32.50.5WG	2NU-DCGW11T302WG																		.375	.156	.0078	.015	.1732
2NU-DCGA32.51	2NU-DCGW11T304																		.375	.156	.0156	.015	.1732
2NU-DCGA32.51LS*	2NU-DCGW11T304LS																		.375	.156	.0156	.015	.1732
2NU-DCGA32.51LE*	2NU-DCGW11T304LE																		.375	.156	.0156	.015	.1732
2NU-DCGA32.51LF*	2NU-DCGW11T304LF																		.375	.156	.0156	.015	.1732
2NU-DCGA32.51W	2NU-DCGW11T304W																		.375	.156	.0156	.015	.1732
2NU-DCGA32.51WG	2NU-DCGW11T304WG																		.375	.156	.0156	.015	.1732
2NU-DCGA32.52	2NU-DCGW11T308																		.375	.156	.0313	.015	.1732
2NU-DCGA32.52LS*	2NU-DCGW11T308LS																		.375	.156	.0313	.015	.1732
2NU-DCGA32.52LE*	2NU-DCGW11T308LE																		.375	.156	.0313	.015	.1732
2NU-DCGA32.52LF*	2NU-DCGW11T308LF																		.375	.156	.0313	.015	.1732
2NU-DCGA32.52W	2NU-DCGW11T308W																		.375	.156	.0313	.015	.1732
2NU-DCGA32.52WG	2NU-DCGW11T308WG																		.375	.156	.0313	.015	.1732

Note: Maximum depth of cut is based on hardened steel applications. Other materials may allow for increased maximum depths of cut.

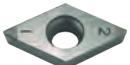
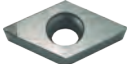

PCBN & PCD Inserts

***EDGE PREPARATIONS:**

See page 579 for descriptions and performance ranges of CBN edge treatments.

- K** Cast Iron
- S** Exotic Materials
- H** Hardened Steel
- S_M** Sintered Materials

- USA Stocked Item
- ★ Worldwide Warehouse Item
- ▲ USA Limited Availability Item
- Available 1st Quarter 2017

DC

55° Diamond Type

7° Relief

DCGT

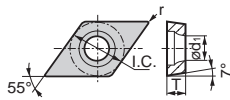

PCBN & PCD Inserts

	Catalog No.	ISO Cat. No.	Coated		Uncoated						Dimensions											
			H		K		H		K		S	M	Inscribed Circle	Thickness	Nose Radius	Max. D. O. C.	Hole Dia. (ød _h)					
			BNC2010	BNC2020	BNC100	BNC160	BNC200	BNC300	BNC500	BNX10								BNX20	BNX25	BN1000	BN2000	BN250
Coated Mini Tip	2NCDCGT21.50.5FV	2NC-DCGT070202N-FV	●	●	●	●											.250	.094	.0078	.015	.110	
	2NCDCGT21.51FV	2NC-DCGT070204N-FV	●	●	●	●												.250	.094	.0156	.015	.110
	2NCDCGT21.52FV	2NC-DCGT070208N-FV	●	●	●	●												.250	.094	.0313	.015	.110
	2NCDCGT32.50.5LV	2NC-DCGT11T302N-FV	●	●	●	●												.375	.156	.0078	.015	.1732
	2NCDCGT32.51LV	2NC-DCGT11T304N-FV	●	●	●	●												.375	.156	.0156	.015	.1732
	2NCDCGT32.52LV	2NC-DCGT11T308N-FV	●	●	●	●												.375	.156	.0313	.015	.1732
Mini Tip	2NUDCGT21.50.5FV	2NU-DCGT070202N-FV																.250	.094	.0078	.015	.110
	2NUDCGT32.50.5FV	2NU-DCGT11T302N-FV																.375	.156	.0078	.015	.1732
	2NUDCGT32.50.5LV	2NU-DCGT11T302N-LV																.375	.156	.0078	.015	.1732
	2NUDCGT32.51LV	2NU-DCGT11T304N-LV																.375	.156	.0156	.015	.1732
	2NUDCGT32.52LV	2NU-DCGT11T308N-LV																.375	.156	.0313	.015	.1732

Note: Maximum depth of cut is based on hardened steel applications. Other materials may allow for increased maximum depths of cut.

RC

Round Type

7° Relief

RCGA RCGX

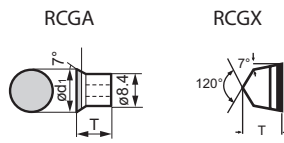

	Catalog No.	ISO Cat. No.	Coated		Uncoated						Dimensions										
			H		K		H		K		S	M	Inscribed Circle	Thickness	Nose Radius	Max. D. O. C.	Hole Diameter				
			BNC2010	BNC2020	BNC100	BNC160	BNC200	BNC300	BNX10	BNX20								BNX25	BN1000	BN2000	BN250
Full Tip	RCGA094	RCGA0906MO															.354	.250	-	.040	-
	RCGX25	RCGX060700															.250	.309	-	.040	-
	RCGX35	RCGX090700															.375	.309	-	.040	-
	RCGX45	RCGX120700															.500	.312	-	.040	-

SP

Square Type

11° Relief

SPG

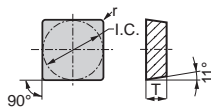

	Catalog No.	ISO Cat. No.	Coated		Uncoated						Dimensions										
			H		K		H		K		S	M	Inscribed Circle	Thickness	Nose Radius	Max. D. O. C.	Hole Diameter				
			BNC2010	BNC2020	BNC100	BNC160	BNC200	BNC300	BNC500	BNX10								BNX20	BNX25	BN1000	BN2000
Full Tip	SPG322	SPGN090308															.375	.125	.0313	.020	-
	SPG421	SPGN120304															.500	.125	.0156	.020	-
Mini Tip	NU-SPG321HS*	NU-SPGN090304HS															.375	.125	.0156	.015	-
	NU-SPG321LT*	NU-SPGN090304LT															.375	.125	.0156	.015	-
	NU-SPG322	NU-SPGN090308															.375	.125	.0313	.015	-
	NU-SPG322HS*	NU-SPGN090308HS															.375	.125	.0313	.015	-
	NU-SPG322LT*	NU-SPGN090308LT															.375	.125	.0313	.015	-

Note: Maximum depth of cut is based on hardened steel applications. Other materials may allow for increased maximum depths of cut.



Cubic Boron Nitride (PCBN) Inserts

See pages 580 - 581 for running parameters.

PCBN

INSERTS - POSITIVE

SPGA • TBGE • TCGA

PCBN & PCD
Inserts

SP

Square Type

11° Relief

- K** Cast Iron
- S** Exotic Materials
- H** Hardened Steel
- S_M** Sintered Materials

- USA Stocked Item
- ★ Worldwide Warehouse Item
- ▲ USA Limited Availability Item
- Available 1st Quarter 2017

***EDGE PREPARATIONS:**
See page 579 for descriptions and performance ranges of CBN edge treatments.

	Catalog No.	ISO Cat. No.	Coated		Uncoated					Dimensions								
			H	K	H	K	S	S	S _M	Inscribed Circle	Thickness	Nose Radius	Max. D. O. C.	Hole Diameter				
Full Tip	SPGA322	SPGW090308	BNC80										.375	.125	.0313	.020	.130	
			BNC100															
			BNC150															
			BNC160															
			BNC200															
			BNC300															
			BNC500															
			BNX10															
			BNX20															
			BNX25															
			BN1000															
			BN2000															
			BN250															
			BN350															
BN7000																		
BN700																		
BN5800																		
BN7500																		

Note: Maximum depth of cut is based on hardened steel applications. Other materials may allow for increased maximum depths of cut.

TB

60° Triangle Type

5° Relief

	Catalog No.	ISO Cat. No.	Coated		Uncoated					Dimensions							
			H	K	H	K	S	S	S _M	Inscribed Circle	Thickness	Nose Radius	Max. D. O. C.	Hole Diameter			
Full Top	TBGE520.5B	TBGE060102B											.156	.0625	.0078	.020	-
	TBGE520.5BSN	TBGE060102-BSN											.156	.0625	.0078	.020	-
	TBGE521B	TBGE060104B											.156	.0625	.0156	.020	-
	TBGE521BSN												.156	.0625	.0156	.020	-
	TBGE522B	TBGE060108B											.156	.0625	.0313	.020	-
	TBGE522BSN												.156	.0625	.0313	.020	-
														.156	.0625	.0313	.020

Note: Maximum depth of cut is based on hardened steel applications. Other materials may allow for increased maximum depths of cut.
BSN = Light edge preparation

TC

60° Triangle Type

7° Relief

	Catalog No.	ISO Cat. No.	Coated		Uncoated					Dimensions								
			H	K	H	K	S	S	S _M	Inscribed Circle	Thickness	Nose Radius	Max. D. O. C.	Hole Diameter				
Multi-Min Tip	3NU-TCGA21.51	3NU-TCGW110204											.250	.156	.0156	.015	.110	
	3NU-TCGA21.52	3NU-TCGW110208											.250	.156	.0313	.015	.110	
	3NU-TCGA32.51	3NU-TCGW16T304											.375	.1875	.0156	.015	.1693	
	3NU-TCGA32.52	3NU-TCGW16T308											.375	.1875	.0313	.015	.1693	
Coated Min Tip	3NC-TCGA21.51	3NC-TCGW110204											.250	.094	.0156	.015	.110	
	3NC-TCGA32.52	3NC-TCGW16T308											.375	.156	.0313	.015	.1693	
	NC-TCGA21.51	NC-TCGW110204											.250	.094	.0156	.015	.110	
	NC-TCGA21.52	NC-TCGW110208											.250	.094	.0313	.015	.110	
														.250	.094	.0313	.015	.110
														.250	.094	.0313	.015	.110

Note: Maximum depth of cut is based on hardened steel applications. Other materials may allow for increased maximum depths of cut.



TP

60° Triangle Type

11° Relief

- K** Cast Iron
- S** Exotic Materials
- H** Hardened Steel
- S_M** Sintered Materials

- USA Stocked Item
- ★ Worldwide Warehouse Item
- ▲ USA Limited Availability Item
- Available 1st Quarter 2017

***EDGE PREPARATIONS:**

See page 579 for descriptions and performance ranges of CBN edge treatments.

PCBN & PCD Inserts

Full Top	TPEE		Coated		Uncoated							Dimensions									
			H		K	H				K		S	S _M	Inscribed Circle	Thickness	Nose Radius	Max. D. O. C.	Hole Diameter			
			BNC80	BNC100	BNC150	BNC160	BNC200	BNC300	BNC500	BNX10	BNX20	BNX25	BN1000						BN2000	BN250	BN350
	TPEE632B	TPEE080208B															.1875	.094	.0313	.020	-
	TPEE632BH	TPEE080208BH															.1875	.094	.0313	.020	-

Note: Maximum depth of cut is based on hardened steel applications. Other materials may allow for increased maximum depths of cut.
H = Hone only

Full Tip	TPG		Coated		Uncoated							Dimensions									
			H		K	H				K		S	S _M	Inscribed Circle	Thickness	Nose Radius	Max. D. O. C.	Hole Diameter			
			BNC2010	BNC2020	BNC100	BNC160	BNC200	BNC300	BNC500	BNX10	BNX20	BNX25	BN1000						BN2000	BN250	BN350
Full Tip	TPG1.81.51	TPGN090204															.219	.094	.0156	.020	-
	TPG1.81.51HS*	TPGN090204HS															.219	.094	.0156	.020	-
	TPG221	TPGN110304															.250	.125	.0156	.020	-
	TPG221HS*	TPGN110304HS															.250	.125	.0156	.020	-
	TPG222	TPGN110308															.250	.125	.0313	.020	-
	TPG222HS*	TPGN110308HS															.250	.125	.0313	.020	-
	TPG321	TPGN160304															.375	.125	.0156	.020	-
	TPG321HS*	TPGN160304HS															.375	.125	.0156	.020	-
	TPG322	TPGN160308															.375	.125	.0313	.020	-
	TPG322HS*	TPGN160308HS															.375	.125	.0313	.020	-
	TPG323	TPGN160312															.375	.125	.0469	.020	-
	TPG432	TPGN220408															.500	.1875	.0313	.020	-
TPG432HS*	TPGN220408HS															.500	.1875	.0313	.020	-	
Multi-Mini Tip	3NU-TPG221	3NU-TPGN110304															.250	.125	.0156	.015	-
	3NU-TPG222	3NU-TPGN110308															.250	.125	.0313	.015	-
	3NU-TPG321	3NU-TPGN160304															.375	.125	.0156	.015	-
	3NU-TPG322	3NU-TPGN160308															.375	.125	.0313	.015	-
Mini Tip	NU-TPG220.5	NU-TPGN110302															.250	.125	.0078	.015	-
	NU-TPG220.5LT*	NU-TPGN110302LT															.250	.125	.0078	.015	-
	NU-TPG221	NU-TPGN110304															.250	.125	.0156	.015	-
	NU-TPG221HS*	NU-TPGN110304HS															.250	.125	.0156	.015	-
	NU-TPG221LT*	NU-TPGN110304LT															.250	.125	.0156	.015	-
	NU-TPG222	NU-TPGN110308															.250	.125	.0313	.015	-
	NU-TPG222HS*	NU-TPGN110308HS															.250	.125	.0313	.015	-
	NU-TPG222LT*	NU-TPGN110308LT															.250	.125	.0313	.015	-
	NU-TPG320.5	NU-TPGN160302															.375	.125	.0078	.015	-
	NU-TPG321	NU-TPGN160304															.375	.125	.0156	.015	-
	NU-TPG321HS*	NU-TPGN160304HS															.375	.125	.0156	.015	-
	NU-TPG321LT*	NU-TPGN160304LT															.375	.125	.0156	.015	-
	NU-TPG322	NU-TPGN160308															.375	.125	.0313	.015	-
	NU-TPG322HS*	NU-TPGN160308HS															.375	.125	.0313	.015	-
NU-TPG322LT*	NU-TPGN160308LT															.375	.125	.0313	.015	-	

Note: Maximum depth of cut is based on hardened steel applications. Other materials may allow for increased maximum depths of cut.



Cubic Boron Nitride (PCBN) Inserts

See pages 580 - 581 for running parameters.

PCBN

INSERTS - POSITIVE

TPGA • TPGD • TPGX

TP

60° Triangle Type

11° Relief

- K** Cast Iron
- S** Exotic Materials
- H** Hardened Steel
- S_M** Sintered Materials

- USA Stocked Item
- ★ Worldwide Warehouse Item
- ▲ USA Limited Availability Item
- Available 1st Quarter 2017

***EDGE PREPARATIONS:**
See page 579 for descriptions and performance ranges of CBN edge treatments.

PCBN & PCD Inserts

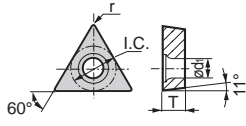
	TPGA TPGD TPGX		Coated													Uncoated					Dimensions							
			H													K	H				K	S	S _M	Inscribed Circle	Thickness	Nose Radius	Max. D. O. C.	Hole Diameter
			BNC2010	BNC2020	BNC100	BNC160	BNC200	BNC300	BNC500	BNX10	BNX20	BNX25	BN1000	BN2000	BN250	BN350	BN7000	BN700	BNS800	BN7500								
Coated Mini Tip	NC-TPGA221	NC-TPGW110304	●	●	●	●	●														.250	.125	.0156	.015	.130			
	NC-TPGA222	NC-TPGW110308	●	●	●	●																.250	.125	.0313	.015	.130		
	3NC-TPGA1.81.50.5	3NC-TPGW090202														★						.219	.094	.0078	.015	.102		
	3NC-TPGA1.81.51	3NC-TPGW090204														★						.219	.094	.0156	.015	.102		
	3NC-TPGA220.5LE*	3NU-TPGW110302LE	★																			.250	.125	.0078	.015	.130		
	3NC-TPGA220.5LT*	3NU-TPGW110302LT		★																		.250	.125	.0078	.015	.130		
	3NC-TPGA221	3NC-TPGW110304		●			●									★						.250	.125	.0156	.015	.130		
	3NC-TPGA221LE*	3NC-TPGW110304LE	★																			.250	.125	.0156	.015	.130		
	3NC-TPGA221LS*	3NC-TPGW110304LS			★	●	●	★														.250	.125	.0156	.015	.130		
	3NC-TPGA221LT*	3NC-TPGW110304LT		●																		.250	.125	.0156	.015	.130		
	3NC-TPGA222	3NC-TPGW110308		●			●									★						.250	.125	.0313	.015	.130		
	3NC-TPGA222LE*	3NC-TPGW110308LE	★																			.250	.125	.0313	.015	.130		
	3NC-TPGA222LS	3NC-TPGW110308LS					●	★														.250	.125	.0313	.015	.130		
	3NC-TPGA222LT*	3NC-TPGW110308LT		●																		.250	.125	.0313	.015	.130		
	Full Tip	3NC-TPGA331	3NC-TPGW160404	●	●	●	★	★				●										.375	.1875	.0156	.015	.1693		
3NC-TPGA331LS		3NC-TPGW160404LS			★	★															.375	.1875	.0156	.015	.1693			
3NC-TPGA332		3NC-TPGW160408	●	●	●	●	★				●										.375	.1875	.0313	.015	.1693			
3NC-TPGA332LS		3NC-TPGW160408LS			★	★															.375	.1875	.0313	.015	.1693			
TPGA221		TPGW110304							●		★	●									.250	.125	.0156	.020	.130			
TPGA221HS*		TPGW110304HS									★										.250	.125	.0156	.020	.130			
TPGA222		TPGW110308										●									.250	.125	.0313	.020	.130			
TPGA222HS*		TPGW110308HS										★									.250	.125	.0313	.020	.130			
TPGA331		TPGW160404								★			●								.375	.1875	.0156	.020	.1693			
TPGA331HS*		TPGW160404HS										★									.375	.1875	.0156	.020	.1693			
TPGA332		TPGW160408									★		★	●							.375	.1875	.0313	.020	.1693			
TPGA332HS*		TPGW160408HS										★		★							.375	.1875	.0313	.020	.1693			
Multi-Mini Tip		3NU-TPGA21.51	3NU-TPGW110204													●	●	●			.250	.094	.0156	.015	.110			
		3NU-TPGA21.51LS*	3NU-TPGW110204LS																			.250	.094	.0156	.015	.110		
		3NU-TPGA21.51LE*	3NU-TPGW110204LE																			.250	.094	.0156	.015	.110		
	3NU-TPGA21.51LF*	3NU-TPGW110204LF																			.250	.094	.0156	.015	.110			
	3NU-TPGA21.52	3NU-TPGW110208														●	●	●			.250	.094	.0313	.015	.110			
	3NU-TPGA220.5	3NU-TPGW110302														●	●	●			.250	.125	.0078	.015	.130			
	3NU-TPGA220.5LF*	3NU-TPGW110302LF																			.250	.125	.0078	.015	.130			
	3NU-TPGA221	3NU-TPGW110304														●	●	●			.250	.125	.0156	.015	.130			
	3NU-TPGA221LS*	3NU-TPGW110304LS																			.250	.125	.0156	.015	.130			
	3NU-TPGA221LE*	3NU-TPGW110304LE																			.250	.125	.0156	.015	.130			
	3NU-TPGA221LF*	3NU-TPGW110304LF																			.250	.125	.0156	.015	.130			
	3NU-TPGA222	3NU-TPGW110308																●	●	●	.250	.125	.0313	.015	.130			
	3NU-TPGA222LF*	3NU-TPGW110308LF																			.250	.125	.0313	.015	.130			
	3NU-TPGA331	3NU-TPGW160404										●		●	●	●	●				.375	.1875	.0156	.015	.1693			
	3NU-TPGA332	3NU-TPGW160408										●		●	●	●	●				.375	.1875	.0313	.015	.1693			
Mini-Tip	NU-TPGX21.50.5	NU-TPGW110202													●					.250	.094	.0078	.015	.110				
	NU-TPGX21.51	NU-TPGW110204													●					.250	.094	.0156	.015	.110				
	NU-TPGX21.51S	NU-TPGW110204S														●				.250	.094	.0156	.015	.110				
	NU-TPGD630.5	NU-TPGW080202													●	●	●	●		.1875	.094	.0078	.015	.090				
	NU-TPGD630.5HS*	NU-TPGW080202HS														●	●	●	●	.1875	.094	.0078	.015	.090				
	NU-TPGD630.5LT*	NU-TPGW080202LT														●				.1875	.094	.0078	.015	.090				
	NU-TPGD630.5S	NU-TPGW080202S														●				.1875	.094	.0078	.015	.090				
	NU-TPGD631	NU-TPGW080204													●		●	●	●	.1875	.094	.0078	.015	.090				
	NU-TPGD631HS*	NU-TPGW080204HS														●		●	●	.1875	.094	.0078	.015	.090				
	NU-TPGD631LT*	NU-TPGW080204LT															●			.1875	.094	.0078	.015	.090				
NU-TPGD631S	NU-TPGW080204S															★			.1875	.094	.0078	.015	.090					

S = Edge preparation for hardened steel boring



TP

60° Triangle Type

11° Relief

- K** Cast Iron
- S** Exotic Materials
- H** Hardened Steel
- S_M** Sintered Materials

- USA Stocked Item
- ★ Worldwide Warehouse Item
- ▲ USA Limited Availability Item
- Available 1st Quarter 2017

***EDGE PREPARATIONS:**

See page 579 for descriptions and performance ranges of CBN edge treatments.

TPGA
TPGD
TPGX
(cont.)

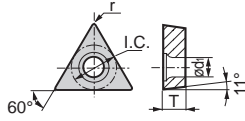

PCBN & PCD Inserts

Mini-Tip



Catalog No.	ISO Cat. No.	Coated										Uncoated					Dimensions									
		H					K	H					K	S	S _M	Inscribed Circle	Thickness	Nose Radius	Max. D. O. C.	Hole Diameter						
		BNC2010	BNC2010	BNC100	BNC160	BNC200	BNC300	BNC500	BNX10	BNX20	BNX25	BN1000	BN2000	BN250	BN350						BN7000	BN700	BN5800	BN7500		
NU-TPGD632	NU-TPGW080208																				.094	.0313	.1875	.015	.090	
NU-TPGD632HS*	NU-TPGW080208HS																					.094	.0313	.1875	.015	.090
NU-TPGA1.81.50.5	NU-TPGW090202																					.219	.094	.0078	.015	.102
NU-TPGA1.81.50.5HS*	NU-TPGW090202HS																					.219	.094	.0078	.015	.102
NU-TPGA1.81.50.5LT*	NU-TPGW090202LT																					.219	.094	.0078	.015	.102
NU-TPGA1.81.51	NU-TPGW090204																					.219	.094	.0156	.015	.102
NU-TPGA1.81.51HS*	NU-TPGW090204HS																					.219	.094	.0156	.015	.102
NU-TPGA1.81.51LT*	NU-TPGW090204LT																					.219	.094	.0156	.015	.102
NU-TPGA1.81.52	NU-TPGW090208																					.219	.094	.0313	.015	.102
NU-TPGA21.50.5	NU-TPGW110202																					.250	.094	.0078	.015	.110
NU-TPGA21.50.5LT*	NU-TPGW110202LT																					.250	.094	.0078	.015	.110
NU-TPGA21.51	NU-TPGW110204																					.250	.094	.0156	.015	.110
NU-TPGA21.51HS*	NU-TPGW110204HS																					.250	.094	.0156	.015	.110
NU-TPGA21.51LT*	NU-TPGW110204LT																					.250	.094	.0156	.015	.110
NU-TPGA220.5	NU-TPGW110302																					.250	.125	.0078	.015	.130
NU-TPGA220.5HS*	NU-TPGW110302HS																					.250	.125	.0078	.015	.130
NU-TPGA220.5LT*	NU-TPGW110302LT																					.250	.125	.0078	.015	.130
NU-TPGA221	NU-TPGW110304																					.250	.125	.0156	.015	.130
NU-TPGA221HS*	NU-TPGW110304HS																					.250	.125	.0156	.015	.130
NU-TPGA221LT*	NU-TPGW110304LT																					.250	.125	.0156	.015	.130
NU-TPGA221S	NU-TPGW110304LT																					.250	.125	.0156	.015	.130
NU-TPGA222	NU-TPGW110308																					.250	.125	.0313	.015	.130
NU-TPGA222HS*	NU-TPGW110308HS																					.250	.125	.0313	.015	.130
NU-TPGA222LT*	NU-TPGW110308LT																					.250	.125	.0313	.015	.130
NU-TPGA222S	NU-TPGW110308S																					.250	.125	.0313	.015	.130
NU-TPGA320.5	NU-TPGW160302																					.375	.125	.0078	.015	.1693
NU-TPGA321	NU-TPGW160304																					.375	.125	.0156	.015	.1693
NU-TPGA322	NU-TPGW160308																					.375	.125	.0313	.015	.1693
NU-TPGA331	NU-TPGW160404																					.375	.1875	.0156	.015	.1693
NU-TPGA331HS*	NU-TPGW160404HS																					.375	.1875	.0156	.015	.1693
NU-TPGA331LT*	NU-TPGW160404LT																					.375	.1875	.0156	.015	.1693
NU-TPGA331S	NU-TPGW160404S																					.375	.1875	.0156	.015	.1693
NU-TPGA332	NU-TPGW160408																					.375	.1875	.0313	.015	.1693
NU-TPGA332HS*	NU-TPGW160408HS																					.375	.1875	.0313	.015	.1693
NU-TPGA332LT*	NU-TPGW160408LT																					.375	.1875	.0313	.015	.1693
NU-TPGA332S	NU-TPGW160408S																					.375	.1875	.0313	.015	.1693

S = Edge preparation for hardened steel boring



Cubic Boron Nitride (PCBN) Inserts

See pages 580 - 581 for running parameters.

PCBN

INSERTS - POSITIVE

VBGA

VB

35° Diamond Type

5° Relief

- K** Cast Iron
- S** Exotic Materials
- H** Hardened Steel
- S_M** Sintered Materials

- USA Stocked Item
- ★ Worldwide Warehouse Item
- ▲ USA Limited Availability Item
- Available 1st Quarter 2017

***EDGE PREPARATIONS:**
See page 579 for descriptions and performance ranges of CBN edge treatments.

VBGA

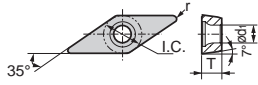

Coated Mini-Tip

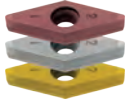

Multi-Mini Tip



Mini-Tip



Catalog No. ISO Cat. No.

		Coated							Uncoated							Dimensions									
		H			K	H			K		S	M	Inscribed Circle	Thickness	Nose Radius	Max. D. O. C.	Hole Diameter								
		BNC2010	BNC2020	BNC100	BNC160	BNC200	BNC300	BNC500	BAX10	BAX20	BAX25	BN1000						BN2000	BN250	BN350	BN7000	BN700	BN800	BN7500	
Coated Mini-Tip	2NC-VBGA220.5LT*	2NC-VBGW110302LT	★																	.250	.125	.0078	.015	.134	
	2NC-VBGA221	2NC-VBGW110304	●	●	●	●	●	★												.250	.125	.0156	.015	.134	
	2NC-VBGA221LS*	2NC-VBGW110304LS			●															.250	.125	.0156	.015	.134	
	2NC-VBGA221LT*	2NC-VBGW110304LT			●															.250	.125	.0156	.015	.134	
	2NC-VBGA222	2NC-VBGW110308				●		★												.250	.125	.0313	.015	.134	
	2NC-VBGA330.5LE*	2NC-VBGW116040LE	★																	.375	.1875	.0078	.015	.1732	
	2NC-VBGA330.5LT*	2NC-VBGW116040LT	★																	.375	.1875	.0078	.015	.1732	
	2NC-VBGA331	2NC-VBGW160404			●		★													.375	.1875	.0156	.015	.1732	
	2NC-VBGA331LE*	2NC-VBGW160404LE	★																	.375	.1875	.0156	.015	.1732	
	2NC-VBGA331LT*	2NC-VBGW160404LT			●															.375	.1875	.0156	.015	.1732	
	2NC-VBGA332	2NC-VBGW160408			●			●												.375	.1875	.0313	.015	.1732	
	2NC-VBGA332LE*	2NC-VBGW160408LE	★																	.375	.1875	.0313	.015	.1732	
	2NC-VBGA332LT*	2NC-VBGW160408LT			●															.375	.1875	.0313	.015	.1732	
Multi-Mini Tip	2NU-VBGA221	2NU-VBGW110304														●	●			.250	.125	.0156	.015	.134	
	2NU-VBGA222	2NU-VBGW110308														●	●			.250	.125	.0313	.015	.134	
	2NU-VBGA331	2NU-VBGW160404														●				.375	.1875	.0156	.015	.1732	
	2NU-VBGA332	2NU-VBGW160408														●				.375	.1875	.0313	.015	.1732	
	Mini-Tip	NU-VBGA220.5	NU-VBGA110302														●				.250	.125	.0078	.015	.134
		NU-VBGA220.5HS*	NU-VBGA110302HS														●				.250	.125	.0078	.015	.134
		NU-VBGA220.5LT*	NU-VBGA110302LT														●				.250	.125	.0078	.015	.134
		NU-VBGA221	NU-VBGA110304														●				.250	.125	.0156	.015	.134
		NU-VBGA221HS*	NU-VBGA110304HS														●				.250	.125	.0156	.015	.134
		NU-VBGA221LT*	NU-VBGA110304LT														●				.250	.125	.0156	.015	.134
		NU-VBGA222	NU-VBGA110308														●				.250	.125	.0313	.015	.134
		NU-VBGA222HS*	NU-VBGA110308HS														●				.250	.125	.0313	.015	.134
		NU-VBGA222LT*	NU-VBGA110308LT														●				.250	.125	.0313	.015	.134
		NU-VBGA330.5	NU-VBGA160402														●				.375	.1875	.0078	.015	.1732
		NU-VBGA330.5LT*	NU-VBGA160402LT														●				.375	.1875	.0078	.015	.1732
		NU-VBGA331	NU-VBGA160404														●				.375	.1875	.0156	.015	.1732
		NU-VBGA331HS*	NU-VBGA160404HS														●				.375	.1875	.0156	.015	.1732
NU-VBGA331LT*		NU-VBGA160404LT														●				.375	.1875	.0156	.015	.1732	
NU-VBGA332		NU-VBGA160408														●				.375	.1875	.0313	.015	.1732	
NU-VBGA332HS*		NU-VBGA160408HS														●				.375	.1875	.0313	.015	.1732	
NU-VBGA332LT*		NU-VBGA160408LT														●				.375	.1875	.0313	.015	.1732	

Note: Maximum depth of cut is based on hardened steel applications. Other materials may allow for increased maximum depths of cut.



***EDGE PREPARATIONS:**

See page 579 for descriptions and performance ranges of CBN edge treatments.

- USA Stocked Item
- ★ Worldwide Warehouse Item
- ▲ USA Limited Availability Item
- Available 1st Quarter 2017

- K** Cast Iron
- S** Exotic Materials
- H** Hardened Steel
- S_M** Sintered Materials

VC

35° Diamond Type

VC

7° Relief

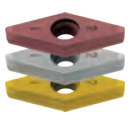
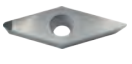
VCGA		Coated		Uncoated		Dimensions																				
				H	K	H	K	S	S _M	Inscribed Circle	Thickness	Nose Radius	Max. D. O. C.	Hole Diameter												
		Catalog No.	ISO Cat. No.	BNC2010	BNC2020	BNC100	BNC160	BNC200	BNC300	BNC500	BAX10	BAX20	BAX25	BAX1000	BN2000	BN250	BN350	BN7000	BN700	BNS800	BN7500					
Coated Mini Tip		2NC-VCGA331	2NC-VCGW160404	●	●	●	●	●																		
		2NC-VCGA331LS*	2NC-VCGW160404LS			★	★																			
		2NC-VCGA331HS*	2NC-VCGW160404HS		●			★																		
		2NC-VCGA332	2NC-VCGW160408	●	●	●	●																			
		2NC-VCGA332LS*	2NC-VCGW160408LS			★	★																			
		2NC-VCGA332HS*	2NC-VCGW160408HS		●			★																		
Mini Tip		NU-VCGA1.51.50.5	NU-VCGW080202												★											
		NU-VCGA1.51.50.5LT*	NU-VCGW080202LT												★											
		NU-VCGA1.51.51	NU-VCGW080204												★											
		NU-VCGA1.51.51HS*	NU-VCGW080204HS												★											
		NU-VCGA1.51.51LT*	NU-VCGW080204LT												★											
		NU-VCGA1.51.52	NU-VCGW080208												★											
		NU-VCGA1.51.52HS*	NU-VCGW080208HS												★											
		NU-VCGA1.51.52LT*	NU-VCGW080208LT												★											
		NU-VCGA220.5	NU-VCGW110302												●	●										
		NU-VCGA220.5HS*	NU-VCGW110302HS												●	●										
		NU-VCGA221	NU-VCGW110304												●	★										
		NU-VCGA221HS*	NU-VCGW110304												●											

Note: Maximum depth of cut is based on hardened steel applications. Other materials may allow for increased maximum depths of cut.

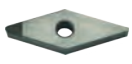
VCMA		Coated		Uncoated		Dimensions																		
				H	K	H	K	S	S _M	Inscribed Circle	Thickness	Nose Radius	Max. D. O. C.	Hole Diameter										
		Catalog No.	ISO Cat. No.	BNC2010	BNC2020	BNC1500	BNC160	BNC200	BNC300	BNC500	BAX10	BAX20	BAX25	BAX1000	BN2000	BN250	BN350	BN7000	BN700	BNS800	BN7500			
Full Tip		VCM331	VCMW160404																					
		VCM332	VCMW160404									★	★											

Note: Maximum depth of cut is based on hardened steel applications. Other materials may allow for increased maximum depths of cut.

ZN

80° Special Shape

ZN

7° Relief

ZNEX		Coated		Uncoated		Dimensions																		
				H	K	H	K	S	S _M	Inscribed Circle	Thickness	Nose Radius	Max. D. O. C.	Hole Diameter										
		Catalog No.	ISO Cat. No.	BNC2010	BNC2020	BNC100	BNC160	BNC200	BNC300	BNC500	BAX10	BAX20	BAX25	BAX1000	BN2000	BN250	BN350	BN7000	BN700	BNS800	BN7500			
Full Tip		NC-ZNEX620.5	NC-ZNEX040102		○			●																
		NC-ZNEX621	NC-ZNEX040104		○			●																
		NU-ZNEX620.5	NU-ZNEX040102												●	●			●					
		NU-ZNEX621	NU-ZNEX040104												●	●			●					

Note: Maximum depth of cut is based on hardened steel applications. Other materials may allow for increased maximum depths of cut.
ZNEX inserts are for use with BNZ holders.



Cubic Boron Nitride (PCBN) Inserts

See pages 580 - 581 for running parameters.

PCBN

INSERTS

BNTT • BNGNT • CGA

THREADING & GROOVING

Threading & Grooving

- K** Cast Iron
- S** Exotic Materials
- H** Hardened Steel
- S/M** Sintered Materials

- USA Stocked Item
- ★ Worldwide Warehouse Item
- ▲ USA Limited Availability Item
- Available 1st Quarter 2017

THREADING INSERTS for BNGG Holder

Full Tip	BNTT		Coated		Uncoated				Dimensions (mm)							
			H		K		H		K		S		Pitch	R	L	S
			BNC2010	BNC2020	BNC100	BNC160	BNC200	BNC300	BNC500	BAX10	BAX20	BAX25				
Catalog No.			BNTT1020R	BNTT1530R									1.0 ~ 2.0	.13	25.0	2.0
Full Tip													1.5 ~ 3.0	.20	25.0	2.0

GROOVING INSERTS for BNGNT Holder

Full Tip	BNGNT		Coated		Uncoated				Dimensions (mm)										
			H		K		H		K		S		W	I	R	L	S		
			BNC2010	BNC2020	BNC100	BNC160	BNC200	BNC300	BNC500	BAX10	BAX20	BAX25						BN1000	BN2000
Catalog No.			BNGNT0200L	BNGNT0200R	BNGNT0250L	BNGNT0250R	BNGNT0300L	BNGNT0300R	BNGNT0400L	BNGNT0400R	BNGNT0500L	BNGNT0500R	BNGNT0600L	BNGNT0600R					
															2.0	4.0	0.2	25.0	6.0
															2.5	4.0	0.2	25.0	6.0
															3.0	5.0	0.4	25.0	6.0
															4.0	6.0	0.4	26.0	6.0
															5.0	6.0	0.4	26.0	6.0
															6.0	7.0	0.4	27.0	6.0

GWB GROOVING INSERTS for GWB Holder

Right				Dimensions (in)					Left			
CGA	CBN			W ±.001 in ±.025 (mm)	a _r in (mm)	r in (mm)	ød in (mm)	s in (mm)	CGA	CBN		
	BN2000	BN250	BNC30G							BN2000	BN250	BNC30G
CGAR4062	●	●	●	.062 (1.575)	.1378 (3.5)				CGAL4062	●	●	●
CGAR4094	●	●	●	.094 (2.388)	.1575 (4.0)			.1875 (4.76)	CGAL4094	●	●	●
CGAR4125	●	●	●	.125 (3.175)	.1969 (5.0)				CGAL4125	●	●	●
CGAR6189	●	●	●	.189 (4.801)				.25 (6.35)	CGAL6189	●	●	●
CGAR1504150	●	●	●	.0591 (1.5)	.1378 (3.5)				CGAL1504150	●	●	●
CGAR1504200	●	●	●	.0787 (2.0)					CGAL1504200	●	●	●
CGAR1504250	●	●	●	.0984 (2.5)	.1575 (4.0)				CGAL1504250	●	●	●
CGAR1504300	●	●	●	.1181 (3.0)		.0078 (.2)	.625 (15.875)	.1875 (4.76)	CGAL1504300	●	●	●
CGAR1504350	●	●	●	.1378 (3.5)					CGAL1504350	●	●	●
CGAR1504400	●	●	●	.1575 (4.0)					CGAL1504400	●	●	●
CGAR1504450	●	●	●	.1772 (4.5)	.1969 (5.0)				CGAL1504450	●	●	●
CGAR1506500	●	★	●	.1969 (5.0)					CGAL1506500	●	★	●
CGAR1506550	●	●	●	.2165 (5.5)				.25 (6.35)	CGAL1506550	●	●	●
CGAR1506600	●	●	●	.2362 (6.0)					CGAL1506600	●	●	●

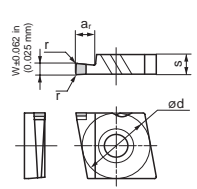

Threading & Grooving

- K** Cast Iron
- S** Exotic Materials
- H** Hardened Steel
- S_M** Sintered Materials

See pages 580 - 581 for running parameters.

- USA Stocked Item
- ★ Worldwide Warehouse Item
- ▲ USA Limited Availability Item
- Available 1st Quarter 2017

SumiNOTCH GROOVING INSERTS for SS & A-SE Holders

SG		Coated				Uncoated				Dimensions (in)															
		H		K	H		K	S																	
		BNC2010	BNC2020	BNC100	BNC160	BNC200	BNC300	BNC500	BNX10	BNX20	BNX25	BN1000	BN2000	BN250	BN350	BN700	BN5800	BN7500	W	R	E	T	A	B	Gage Dia.
Full Tip	Catalog No.																±.001		±.001						
	SG-3047R											●	●	●			.047	.005/.010	.075	.195	.344	.4050	.3750		
	SG-3062L											●	●	●			.062	.005/.010	.094	.195	.344	.4050	.3750		
	SG-3062R											●	●	●			.062	.005/.010	.094	.195	.344	.4050	.3750		
	SG-3094L											●	●	●			.094	.005/.010	.150	.195	.344	.4050	.3750		
	SG-3094R											●	●	●			.094	.005/.010	.150	.195	.344	.4050	.3750		
	SG-3125L											●	●	●			.125	.005/.010	.150	.195	.344	.4050	.3750		
	SG-3125R											●	●	●			.125	.005/.010	.150	.195	.344	.4050	.3750		
	SG-3189R											●	●	●			.189	.020/.025	.150	.195	.344	.4050	.3750		

PCD INSERTS - NEGATIVE

CN 80° Diamond Type
Negative

EDGE PREPARATIONS:

- S Standard
- H Honed
- K Reinforced
- AW Chipbreaker Stud
- WF High Luster "Mirror-Like" Finish

CNMA		Stock				Dimensions						
		N				Inscribed Circle	Thickness	Nose Radius	Hole Diameter	Edge Preparation	Rake Angle	
Catalog No.	ISO Cat. No.	DA90	DA150	DA1000	DA2200							
Standard Tip	CNMA432	CNMA120408				●	.500	.1875	.0313	.2031	S	0°
	CNMA432H	CNMA120408H				●	.500	.1875	.0313	.2031	H	0°
NF Tip	NF-CNMA432	NF-CNMA120408				●	.500	.1875	.0313	.2031	S	0°
	NF-CNMA432H	NF-CNMA120408H				●	.500	.1875	.0313	.2031	H	0°

CNMX		Stock				Dimensions						
		N				Inscribed Circle	Thickness	Nose Radius	Hole Diameter	Edge Preparation	Rake Angle	
Catalog No.	ISO Cat. No.	DA90	DA150	DA1000	DA2200							
Standard Tip	CNMX431	CNMX120404				●	.500	.1875	.0156	.2031	S	10°
	CNMX432	CNMX120408				●	.500	.1875	.0313	.2031	S	10°
	CNMX433	CNMX120412				●	.500	.1875	.0469	.2031	S	10°
NF Tip	NF-CNMX431	NF-CNMX120404				●	.500	.1875	.0156	.2031	S	10°
	NF-CNMX432	NF-CNMX120408				●	.500	.1875	.0313	.2031	S	10°
	NF-CNMX433	NF-CNMX120412				★	.500	.1875	.0469	.2031	S	10°



Polycrystalline Diamond (PCD) Inserts

See page 583 for running parameters.

PCD

INSERTS - NEGATIVE

CNMX • DNMA • DNMX

CN

80° Diamond Type

Negative

EDGE PREPARATIONS:

- S Standard
- H Honed
- K Reinforced
- AW Chipbreaker Stud
- WF High Luster "Mirror-Like" Finish

- USA Stocked Item
- ★ Worldwide Warehouse Item
- ▲ USA Limited Availability Item
- Available 1st Quarter 2017

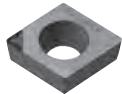
	Catalog No.	ISO Cat. No.	Stock					Dimensions					
			N					Inscribed Circle	Thickness	Nose Radius	Hole Diameter	Edge Preparation	Rake Angle
			DA90	DA150	DA200	DA1000	DA2200						
	NF-CNMX431LD	NF-CNMX120404LD				●	.500	.1875	.0156	.2031	S	0°	
	NF-CNMX431GD	NF-CNMX120404GD				●	.500	.1875	.0156	.2031	S	0°	
	NF-CNMX432LD	NF-CNMX120408LD				●	.500	.1875	.0312	.2031	S	0°	
	NF-CNMX432GD	NF-CNMX120408GD				●	.500	.1875	.0312	.2031	S	0°	
	NF-CNMX433LD	NF-CNMX120412LD				●	.500	.1875	.0469	.2031	S	0°	
	NF-CNMX433GD	NF-CNMX120412GD				●	.500	.1875	.0469	.2031	S	0°	
							●	.500	.1875	.0469	.2031	S	0°

DN

55° Diamond Type

Negative

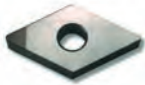
	Catalog No.	ISO Cat. No.	Stock				Dimensions					
			N				Inscribed Circle	Thickness	Nose Radius	Hole Diameter	Edge Preparation	Rake Angle
			DA90	DA150	DA1000	DA2200						
	DNMA432	DNMA150408				●	.500	.1875	.0313	.2031	S	0°
	DNMA432H	DNMA150408H				●	.500	.1875	.0313	.2031	H	0°
	NF-DNMA432	NF-DNMA150408				●	.500	.1875	.0313	.2031	S	0°
	NF-DNMA432H	NF-DNMA150408H				●	.500	.1875	.0313	.2031	H	0°

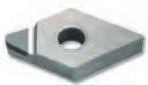
	Catalog No.	ISO Cat. No.	Stock				Dimensions					
			N				Inscribed Circle	Thickness	Nose Radius	Hole Diameter	Edge Preparation	Rake Angle
			DA90	DA150	DA1000	DA2200						
	DNMX431	DNMX150404		●	●	.500	.1875	.0156	.2031	S	10°	
	DNMX432	DNMX150408		●	●	.500	.1875	.0313	.2031	S	10°	
	DNMX433	DNMX150412		●	●	.500	.1875	.0469	.2031	S	10°	
	NF-DNMX430.5	NF-DNMX150402			●	●	.500	.1875	.0078	.2031	S	10°
	NF-DNMX431	NF-DNMX150404			●	●	.500	.1875	.0156	.2031	S	10°
	NF-DNMX432	NF-DNMX150408			●	●	.500	.1875	.0313	.2031	S	10°
NF-DNMX433	NF-DNMX150412			★	★	.500	.1875	.0469	.2031	S	10°	



DN

55° Diamond Type

Negative

EDGE PREPARATIONS:

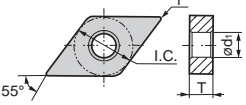
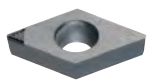

- | | | | |
|----|----------------------------------|---|-------------------------------|
| S | Standard | ● | USA Stocked Item |
| H | Honed | ★ | Worldwide Warehouse Item |
| K | Reinforced | ▲ | USA Limited Availability Item |
| AW | Chipbreaker Stud | ○ | Available 1st Quarter 2017 |
| WF | High Luster "Mirror-Like" Finish | | |

DNMX with Chipbreaker			Stock					Dimensions					
			DA90	DA150	DA200	DA1000	DA2200	Inscribed Circle	Thickness	Nose Radius	Hole Diameter	Edge Preparation	Rake Angle
	Catalog No.	ISO Cat. No.				●		.500	.1875	.0078	.2031	S	0°
	NF-DNMX430.5LD	NF-DNMX150402LD				●		.500	.1875	.0078	.2031	S	0°
	NF-DNMX430.5GD	NF-DNMX150402GD				●		.500	.1875	.0156	.2031	S	0°
	NF-DNMX431LD	NF-DNMX150404LD				●		.500	.1875	.0156	.2031	S	0°
	NF-DNMX431GD	NF-DNMX150404GD				●		.500	.1875	.0312	.2031	S	0°
	NF-DNMX432LD	NF-DNMX150408LD				●		.500	.1875	.0312	.2031	S	0°
	NF-DNMX432GD	NF-DNMX150408GD				●		.500	.1875	.0469	.2031	S	0°
	NF-DNMX433LD	NF-DNMX150412LD				●		.500	.1875	.0469	.2031	S	0°
NF-DNMX433GD	NF-DNMX150412GD				●		.500	.1875	.0469	.2031	S	0°	

TN

60° Diamond Type

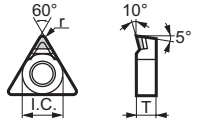
Negative

TNMX			Stock				Dimensions						
			DA90	DA150	DA1000	DA2200	Inscribed Circle	Thickness	Nose Radius	Hole Diameter	Edge Preparation	Rake Angle	
	Catalog No.	ISO Cat. No.				★		.375	.1875	.0156	.150	S	10°
	TNMX331	TNMX160404				★		.375	.1875	.0313	.150	S	10°
	NF-TNMX330.5	NF-TNMX160402			●	●		.375	.1875	.0078	.150	S	10°
	NF-TNMX331	NF-TNMX160404			●	●		.375	.1875	.0156	.150	S	10°
	NF-TNMX332	NF-TNMX160408			●	●		.375	.1875	.0313	.150	S	10°

VN

35° Diamond Type

Negative

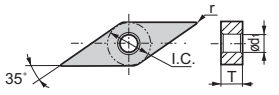
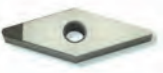
VNMA			Stock				Dimensions						
			DA90	DA150	DA1000	DA2200	Inscribed Circle	Thickness	Nose Radius	Hole Diameter	Edge Preparation	Rake Angle	
	Catalog No.	ISO Cat. No.	●			●		.375	.1875	.0469	.150	H	0°
	VNMA333H	VNMA160412H				●	●	.375	.1875	.0313	.150	S	0°
	NF-VNMA332	NF-VNMA160408				●	●	.375	.1875	.0469	.150	S	0°
	NF-VNMA333	NF-VNMA160412				●	●	.375	.1875	.0469	.150	H	0°
NF-VNMA333H	NF-VNMA160412H				●		.375	.1875	.0469	.150	H	0°	



Polycrystalline Diamond (PCD) Inserts

See page 583 for running parameters.

PCD

INSERTS - POSITIVE

VNMX • CCMT

VN

35° Diamond Type

Negative

EDGE PREPARATIONS:

- | | | | |
|----|----------------------------------|---|-------------------------------|
| S | Standard | ● | USA Stocked Item |
| H | Honed | ★ | Worldwide Warehouse Item |
| K | Reinforced | ▲ | USA Limited Availability Item |
| AW | Chipbreaker Stud | ○ | Available 1st Quarter 2017 |
| WF | High Luster "Mirror-Like" Finish | | |

	VNMX	Diagram		Stock				Dimensions					
				DA90	DA150	DA1000	DA2200	Inscribed Circle	Thickness	Nose Radius	Hole Diameter	Edge Preparation	Rake Angle
		Catalog No.	ISO Cat. No.										
Standard Tip		VNMX331	VNMX160404	●	●	●	●	.375	.1875	.0156	.150	S	10°
		VNMX332	VNMX160408	●	●	●	●	.375	.1875	.0313	.150	S	10°
		VNMX333	VNMX160412	●	●	●	●	.375	.1875	.0469	.150	S	10°
NF Tip		NF-VNMX330.5	NF-VNMX160402		●	●	●	.375	.1875	.0078	.150	S	10°
		NF-VNMX331	NF-VNMX160404		●	●	●	.375	.1875	.0156	.150	S	10°
		NF-VNMX332	NF-VNMX160408		●	●	●	.375	.1875	.0313	.150	S	10°
		NF-VNMX333	NF-VNMX160412		★	●	●	.375	.1875	.0469	.150	S	10°

	VNMX with Chipbreaker	Diagram		Stock					Dimensions					
				DA90	DA150	DA200	DA1000	DA2200	Inscribed Circle	Thickness	Nose Radius	Hole Diameter	Edge Preparation	Rake Angle
		Catalog No.	ISO Cat. No.											
		NF-VNMX330.5LD	NF-VNMX160402LD				●		.375	.1875	.0078	.150	S	0°
		NF-VNMX330.5GD	NF-VNMX160402GD				●		.375	.1875	.0078	.150	S	0°
		NF-VNMX331LD	NF-VNMX160404LD				●		.375	.1875	.0156	.150	S	0°
		NF-VNMX331GD	NF-VNMX160404GD				●		.375	.1875	.0156	.150	S	0°
		NF-VNMX332LD	NF-VNMX160408LD				●		.375	.1875	.0312	.150	S	0°
		NF-VNMX332GD	NF-VNMX160408GD				●		.375	.1875	.0312	.150	S	0°
		NF-VNMX333LD	NF-VNMX160412LD				●		.375	.1875	.0469	.150	S	0°
		NF-VNMX333GD	NF-VNMX160412GD				●		.375	.1875	.0469	.150	S	0°

PCD INSERTS - POSITIVE

CC

80° Diamond Type

7° Relief

	CCMT with Chipbreaker	Diagram		Stock					Dimensions					
				DA90	DA150	DA200	DA1000	DA2200	Inscribed Circle	Thickness	Nose Radius	Hole Diameter	Edge Preparation	Rake Angle
		Catalog No.	ISO Cat. No.											
		NF-CCMT21.50.5GD	NF-CCMT060202N-GD				●		.250	.094	.0078	.107	S	0°
		NF-CCMT21.50.5LD	NF-CCMT060202N-LD				●		.250	.094	.0078	.107	S	0°
		NF-CCMT21.51GD	NF-CCMT060204N-GD				●		.250	.094	.0156	.107	S	0°
		NF-CCMT21.51LD	NF-CCMT060204N-LD				●		.250	.094	.0156	.107	S	0°
		NF-CCMT32.50.5GD	NF-CCMT09T302N-GD				●		.375	.156	.0078	.1732	S	0°
		NF-CCMT32.50.5LD	NF-CCMT09T302N-LD				●		.375	.156	.0078	.1732	S	0°
		NF-CCMT32.51GD	NF-CCMT09T304N-GD				●		.375	.156	.0156	.1732	S	0°
		NF-CCMT32.51LD	NF-CCMT09T304N-LD				●		.375	.156	.0156	.1732	S	0°
		NF-CCMT32.52GD	NF-CCMT09T308N-GD				●		.375	.156	.0312	.1732	S	0°
		NF-CCMT32.52LD	NF-CCMT09T308N-LD				●		.375	.156	.0312	.1732	S	0°



CC

80° Diamond Type

CC

7° Relief

EDGE PREPARATIONS:

- | | | | |
|----|----------------------------------|---|-------------------------------|
| S | Standard | ● | USA Stocked Item |
| H | Honed | ★ | Worldwide Warehouse Item |
| K | Reinforced | ▲ | USA Limited Availability Item |
| AW | Chipbreaker Stud | ○ | Available 1st Quarter 2017 |
| WF | High Luster "Mirror-Like" Finish | | |

	Catalog No.	ISO Cat. No.	Stock				Dimensions					
			DA90	DA150	DA1000	DA2200	Inscribed Circle	Thickness	Nose Radius	Hole Diameter	Edge Preparation	Rake Angle
NF Tip	NF-CCMX21.50	NF-CCMT060201			●	●	.250	.094	.0039	.110	S	10°
	NF-CCMX21.50.5	NF-CCMT060202			●	●	.250	.094	.0078	.110	S	10°
	NF-CCMX21.51	NF-CCMT060204			●	●	.250	.094	.0156	.110	S	10°
	NF-CCMX32.50.5	NF-CCMT09T302			●	●	.375	.156	.0078	.1732	S	10°
	NF-CCMX32.51	NF-CCMT09T304			●	●	.375	.156	.0156	.1732	S	10°
	NF-CCMX32.52	NF-CCMT09T308			●	●	.375	.156	.0313	.1732	S	10°

CP

80° Diamond Type

CP

11° Relief

	Catalog No.	ISO Cat. No.	Stock				Dimensions					
			DA90	DA150	DA1000	DA2200	Inscribed Circle	Thickness	Nose Radius	Hole Diameter	Edge Preparation	Rake Angle
Standard Tip	CPMX2.51.50.5	CPMT080202			●	●	.3125	.094	.0078	.134	S	10°
	CPMX2.51.51	CPMT080204			●	●	.3125	.094	.0156	.134	S	10°
	CPMX2.51.52	CPMT080208			●	●	.3125	.094	.0313	.134	S	10°
	CPMX320.5	CPMT090302			●	●	.375	.125	.0078	.1732	S	10°
	CPMX321	CPMT090304			●	●	.375	.125	.0156	.1732	S	10°
	CPMX322	CPMT090308			●	●	.375	.125	.0313	.1732	S	10°
NF Tip	NF-CPMX21.51	NF-CPMT060204			●	●	.250	.094	.0156	.110	S	10°
	NF-CPMX21.52	NF-CPMT060208			●	●	.250	.094	.0313	.110	S	10°
	NF-CPMX32.51	NF-CPMT09T304			●	●	.375	.156	.0156	.1732	S	10°
	NF-CPMX32.52	NF-CPMT09T308			●	●	.375	.156	.0313	.1732	S	10°
	NF-CPMX320.5	NF-CPMT090302			●	●	.375	.125	.0078	.1732	S	10°
	NF-CPMX321	NF-CPMT090304			●	●	.375	.125	.0156	.1732	S	10°
NF-CPMX322	NF-CPMT090308			●	●	.375	.125	.0313	.1732	S	10°	

	Catalog No.	ISO Cat. No.	Stock				Dimensions					
			DA90	DA150	DA1000	DA2200	Inscribed Circle	Thickness	Nose Radius	Hole Diameter	Edge Preparation	Rake Angle
Standard Tip	CPG422	CPGN120308			●	●	.500	.125	.0313	-	S	0°



Polycrystalline Diamond (PCD) Inserts

See page 583 for running parameters.

PCD

INSERTS - POSITIVE

CPGA • CPEW • DCGA • DCMT



CP



80° Diamond Type

11° Relief

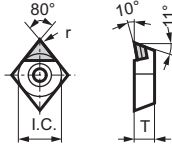
EDGE PREPARATIONS:

- S Standard
- H Honed
- K Reinforced
- AW Chipbreaker Stud
- WF High Luster "Mirror-Like" Finish
- USA Stocked Item
- ★ Worldwide Warehouse Item
- ▲ USA Limited Availability Item
- Available 1st Quarter 2017

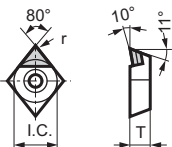

	CPGA			Stock				Dimensions				
				DA90	DA150	DA1000	DA2200	Inscribed Circle	Thickness	Nose Radius	Hole Diameter	Edge Preparation
NF Tip		Catalog No.	ISO Cat. No.									
		NF-CPGA321	NF-CPGW090304	●		.375	.125	.0156	.1732	S	10°	
		NF-CPGA322	NF-CPGW090308	●		.375	.125	.0313	.1732	S	10°	

	CPEW			Stock				Dimensions				
				DA90	DA150	DA1000	DA2200	Inscribed Circle	Thickness	Nose Radius	Hole Diameter	Edge Preparation
Standard Tip		Catalog No.	ISO Cat. No.									
		CPEW32.52	CPEW09T308	●		.375	.156	.0313	.1732	S	10°	

DC

55° Diamond Type

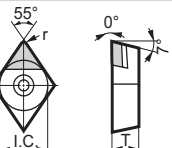
7° Relief

	DCGA			Stock				Dimensions				
				DA90	DA150	DA1000	DA2200	Inscribed Circle	Thickness	Nose Radius	Hole Diameter	Edge Preparation
NF Tip		Catalog No.	ISO Cat. No.									
		NF-DCGA32.50.5	NF-DCGT11T302	●		.375	.156	.0078	.1732	S	0°	
		NF-DCGA32.51	NF-DCGT11T304	●		.375	.156	.0156	.1732	S	0°	
		NF-DCGA32.52	NF-DCGT11T308	●		.375	.156	.0313	.1732	S	0°	

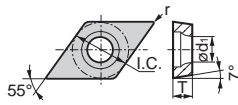
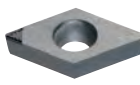
	DCMT with Chipbreaker			Stock				Dimensions				
				DA90	DA150	DA200	DA1000	DA2200	Inscribed Circle	Thickness	Nose Radius	Hole Diameter
	Catalog No.	ISO Cat. No.										
	NF-DCMT21.50.5GD	NF-DCMT070202N-GD	●		.250	.094	.0078	.107	S	0°		
	NF-DCMT21.50.5LD	NF-DCMT070202N-LD	●		.250	.094	.0078	.107	S	0°		
	NF-DCMT21.51GD	NF-DCMT070204N-GD	●		.250	.094	.0156	.107	S	0°		
	NF-DCMT21.51LD	NF-DCMT070204N-LD	●		.250	.094	.0156	.107	S	0°		
	NF-DCMT32.50.5GD	NF-DCMT11T302N-GD	●		.375	.156	.0078	.1732	S	0°		
	NF-DCMT32.50.5LD	NF-DCMT11T302N-LD	●		.375	.156	.0078	.1732	S	0°		
	NF-DCMT32.51GD	NF-DCMT11T304N-GD	●		.375	.156	.0156	.1732	S	0°		
	NF-DCMT32.51LD	NF-DCMT11T304N-LD	●		.375	.156	.0156	.1732	S	0°		
	NF-DCMT32.52GD	NF-DCMT11T308N-GD	●		.375	.156	.0312	.1732	S	0°		
	NF-DCMT32.52LD	NF-DCMT11T308N-LD	●		.375	.156	.0312	.1732	S	0°		



DC

55° Diamond Type

7° Relief

EDGE PREPARATIONS:

- | | | | |
|----|----------------------------------|---|-------------------------------|
| S | Standard | ● | USA Stocked Item |
| H | Honed | ★ | Worldwide Warehouse Item |
| K | Reinforced | ▲ | USA Limited Availability Item |
| AW | Chipbreaker Stud | ○ | Available 1st Quarter 2017 |
| WF | High Luster "Mirror-Like" Finish | | |

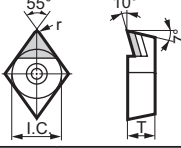
	DCMX			Stock				Dimensions				
				N				Inscribed Circle	Thickness	Nose Radius	Hole Diameter	Edge Preparation
	Catalog No.	ISO Cat. No.	DA90	DA150	DA1000	DA2200						
Standard Tip	DCMX21.50	DCMT070201				●	.250	.094	.0039	.110	S	10°
	DCMX21.50.5	DCMT070202				●	.250	.094	.0078	.110	S	10°
	DCMX21.51	DCMT070204				●	.250	.094	.0156	.110	S	10°
	DCMX32.50	DCMT11T301				●	.375	.156	.0039	.1732	S	10°
	DCMX32.50.5	DCMT11T302				●	.375	.156	.0078	.1732	S	10°
	DCMX32.51	DCMT11T304				●	.375	.156	.0156	.1732	S	10°
NF Tip	NF-DCMX21.50	NF-DCMT070201			●	●	.250	.094	.0039	.110	S	10°
	NF-DCMX21.50.5	NF-DCMT070202			●	●	.250	.094	.0078	.110	S	10°
	NF-DCMX21.51	NF-DCMT070204			●	●	.250	.094	.0156	.110	S	10°
	NF-DCMX32.50	NF-DCMT11T301			●	●	.375	.156	.0039	.1732	S	10°
	NF-DCMX32.50.5	NF-DCMT11T302			●	●	.375	.156	.0078	.1732	S	10°
	NF-DCMX32.51	NF-DCMT11T304			●	●	.375	.156	.0156	.1732	S	10°
	NF-DCMX32.52	NF-DCMT11T308			●	●	.375	.156	.0313	.1732	S	10°

SP

Square Type

11° Relief

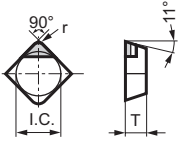
	SPG			Stock				Dimensions					
				N				Inscribed Circle	Thickness	Nose Radius	Hole Diameter	Edge Preparation	Rake Angle
	Catalog No.	ISO Cat. No.	DA90	DA150	DA1000	DA2200							
Standard Tip	SPG322	SPGN090308		●		●	.375	.125	.0313	-	S	0°	
	SPG421	SPGN120304		●		●	.500	.125	.0156	-	S	0°	
	SPG422	SPGN120308					●	.500	.125	.0313	-	S	0°
NF Tip	NF-SPG321	NF-SPGN090304				★	.375	.125	.0156	-	S	0°	
	NF-SPG322	NF-SPGN090308				★	.375	.125	.0313	-	S	0°	
	NF-SPG421	NF-SPGN120304				★	▲	.500	.125	.0156	-	S	0°
	NF-SPG422	NF-SPGN120308				★	●	.500	.125	.0313	-	S	0°



Polycrystalline Diamond (PCD) Inserts

See page 583 for running parameters.

PCD

INSERTS - POSITIVE

TBGE • TCMX • TEGN

PCBN & PCD
Inserts



TB

60° Triangle Type

5° Relief

EDGE PREPARATIONS:

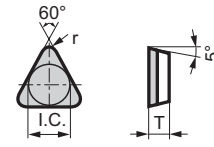

- | | |
|--|---|
| <p>S Standard
H Honed
K Reinforced
AW Chipbreaker Stud
WF High Luster "Mirror-Like" Finish</p> | <p>● USA Stocked Item
★ Worldwide Warehouse Item
▲ USA Limited Availability Item
○ Available 1st Quarter 2017</p> |
|--|---|

	TBGE			Stock				Dimensions					
				DA90	DA150	DA1000	DA2200	Inscribed Circle	Thickness	Nose Radius	Hole Diameter	Edge Preparation	Rake Angle
		Catalog No.	ISO Cat. No.										
Full Tip		TBGE520.5B	TBGE060102BSN	●	●	.156	.0625	.0078	-	S	0°		
		TBGE521B	TBGE060104BSN	●	●	.156	.0625	.0156	-	S	0°		
		TBGE522B	TBGE060108BSN	●	●	.156	.0625	.0313	-	S	0°		
NF Tip		NF-TBGE520.5	NF-TBGN060102	●	●	.156	.0625	.0078	-	S	0°		
		NF-TBGE521	NF-TBGN060104	★	★	.156	.0625	.0156	-	S	0°		

TC

60° Triangle Type

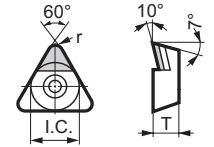

7° Relief

	TCMX			Stock				Dimensions				
				DA90	DA150	DA1000	DA2200	Inscribed Circle	Thickness	Nose Radius	Hole Diameter	Edge Preparation
		Catalog No.	ISO Cat. No.									
Standard Tip		TCMX1.81.50.5	TCMT090202	●	●	.219	.094	.0078	.110	S	10°	
		TCMX1.81.51	TCMT090204	●	●	.219	.094	.0156	.110	S	10°	
		TCMX21.50	TCMT110201	●	●	.250	.094	.0039	.110	S	10°	
		TCMX21.50.5	TCMT110202	▲	●	.250	.094	.0078	.110	S	10°	
		TCMX21.51	TCMT110204	●	●	.250	.094	.0156	.110	S	10°	
NF Tip		NF-TCMX1.81.50.5	NF-TCMT090202	●	▲	.219	.094	.0078	.098	S	10°	
		NF-TCMX1.81.51	NF-TCMT090204	●	●	.219	.094	.0156	.098	S	10°	
		NF-TCMX21.50	NF-TCMT110201	●	▲	.250	.094	.0039	.110	S	10°	
		NF-TCMX21.50.5	NF-TCMT110202	●	●	.250	.094	.0078	.110	S	10°	
		NF-TCMX21.51	NF-TCMT110204	●	●	.250	.094	.0156	.110	S	10°	

TE

60° Triangle Type

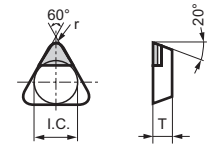
20° Relief

	TEGN			Stock				Dimensions					
				DA90	DA150	DA1000	DA2200	Inscribed Circle	Thickness	Nose Radius	Hole Diameter	Edge Preparation	Rake Angle
		Catalog No.	ISO Cat. No.										
Standard Tip		TEGN321	TEGN160304				★	.375	.125	.0156	-	S	0°



TP

60° Triangle Type

11° Relief

EDGE PREPARATIONS:

S Standard
 H Honed
 K Reinforced
 AW Chipbreaker Stud
 WF High Luster "Mirror-Like"
 Finish

● USA Stocked Item
 ★ Worldwide Warehouse Item
 ▲ USA Limited Availability Item
 ○ Available 1st Quarter 2017

TPG

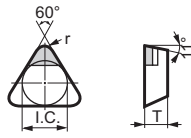

Catalog No.

ISO Cat. No.

	Stock					Dimensions					
	N					Inscribed Circle	Thickness	Nose Radius	Hole Diameter	Edge Preparation	Rake Angle
	DA90	DA150	DA200	DA1000	DA2200						
Standard Tip	TPG221	TPGN110304	●	★	●	.250	.125	.0156	-	S	0°
	TPG222	TPGN110308	●	●	●	.250	.125	.0313	-	S	0°
	TPG321	TPGN160304	●	●	●	.375	.125	.0156	-	S	0°
	TPG322	TPGN160308	●	▲	●	.375	.125	.0313	-	S	0°
	TPG323	TPGN160312	●	●	●	.375	.125	.0469	-	S	0°
	TPG431	TPGN220404		▲	●	.500	.1875	.0156	-	S	0°
	TPG432	TPGN220408		●	●	.500	.1875	.0313	-	S	0°
NF Tip	NF-TPG1.81.51	NF-TPGN090204			●	.219	.094	.0156	-	S	0°
	NF-TPG220.5	NF-TPGN110302			●	.250	.125	.0078	-	S	0°
	NF-TPG221	NF-TPGN110304			●	.250	.125	.0156	-	S	0°
	NF-TPG222	NF-TPGN110308			●	.250	.125	.0313	-	S	0°
	NF-TPG320.5	NF-TPGN160302			●	.375	.125	.0078	-	S	0°
	NF-TPG321	NF-TPGN160304			●	.375	.125	.0156	-	S	0°
	NF-TPG322	NF-TPGN160308			●	.375	.125	.0313	-	S	0°

TPG-P

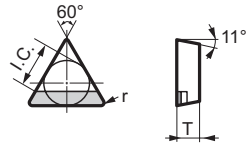

Catalog No.

ISO Cat. No.

	Stock				Dimensions					
	N				Inscribed Circle	Thickness	Nose Radius	Hole Diameter	Edge Preparation	Rake Angle
	DA90	DA150	DA1000	DA2200						
NF Tip	NF-TPG221P	NF-TPGN110304P	★	★	.250	.125	.0156	-	S	0°
	NF-TPG222P	NF-TPGN110308P	★	★	.250	.125	.0313	-	S	0°
	NF-TPG321P	NF-TPGN160304P	★	★	.375	.125	.0156	-	S	0°



Polycrystalline Diamond (PCD) Inserts

See page 583 for running parameters.

PCD

INSERTS - POSITIVE

TPGA • TPGD

TP

60° Triangle Type

11° Relief

EDGE PREPARATIONS:

- S Standard
- H Honed
- K Reinforced
- AW Chipbreaker Stud
- WF High Luster "Mirror-Like" Finish

- USA Stocked Item
- ★ Worldwide Warehouse Item
- ▲ USA Limited Availability Item
- Available 1st Quarter 2017

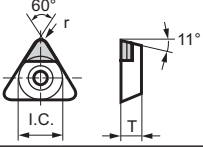
	TPGA TPGD		Stock					Dimensions					
			DA90	DA150	DA200	DA1000	DA2200	Inscribed Circle	Thickness	Nose Radius	Hole Diameter	Edge Preparation	Rake Angle
		Catalog No.	ISO Cat. No.										
Standard Tip		TPGA220	TPGW110301				●	.250	.125	.0039	.130	S	0°
		TPGA220.5	TPGW110302				●	.250	.125	.0078	.130	S	0°
		TPGA221	TPGW110304				●	.250	.125	.0156	.130	S	0°
		TPGA222	TPGW110308		★		●	.250	.125	.0313	.130	S	0°
		TPGA331	TPGW160404		●	▲	●	.375	.1875	.0156	.1693	S	0°
		TPGA332	TPGW160408		●		●	.375	.1875	.0313	.1693	S	0°
NF Tip		NF-TPGD630	NF-TPGW080201				★	.1875	.094	.0039	.090	S	0°
		NF-TPGD630.5	NF-TPGW080202				●	.1875	.094	.0078	.090	S	0°
		NF-TPGD631	NF-TPGW080204				●	.1875	.094	.0156	.090	S	0°
		NF-TPGA1.81.50.5	NF-TPGW090202				●	.219	.094	.0078	.102	S	0°
		NF-TPGA1.81.51	NF-TPGW090204				●	.219	.094	.0156	.102	S	0°
		NF-TPGA21.50	NF-TPGW110201				●	.250	.094	.0039	.107	S	0°
		NF-TPGA21.50.5	NF-TPGW110202				●	.250	.094	.0078	.107	S	0°
		NF-TPGA21.51	NF-TPGW110204				●	.250	.094	.0156	.107	S	0°
		NF-TPGA220.5	NF-TPGW110302				●	.250	.125	.0078	.130	S	0°
		NF-TPGA221	NF-TPGW110304				●	.250	.125	.0156	.130	S	0°
		NF-TPGA222	NF-TPGW110308				●	.250	.125	.0313	.130	S	0°
		NF-TPGA320.5	NF-TPGW160302				●	.375	.125	.0078	.1693	S	0°
		NF-TPGA321	NF-TPGW160304				●	.375	.125	.0156	.1693	S	0°
		NF-TPGA322	NF-TPGW160308				●	.375	.125	.0313	.1693	S	0°
		NF-TPGA330	NF-TPGW160401				★	.375	.1875	.0039	.1693	S	0°
		NF-TPGA330.5	NF-TPGW160402				●	.375	.1875	.0078	.1693	S	0°
		NF-TPGA331	NF-TPGW160404				●	.375	.1875	.0156	.1693	S	0°
		NF-TPGA332	NF-TPGW160408				●	.375	.1875	.0313	.1693	S	0°

PCBN & PCD Inserts



TP

60° Triangle Type

11° Relief

- S Standard
- H Honed
- K Reinforced
- AW Chipbreaker Stud
- WF High Luster "Mirror-Like" Finish

- USA Stocked Item
- ★ Worldwide Warehouse Item
- ▲ USA Limited Availability Item
- Available 1st Quarter 2017

TPMT

with
Chipbreaker

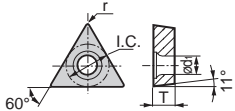

PCBN & PCD Inserts

	Catalog No.	ISO Cat. No.	Stock					Dimensions					
			N					Inscribed Circle	Thickness	Nose Radius	Hole Diameter	Edge Preparation	Rake Angle
			DA90	DA150	DA200	DA1000	DA2200						
NF-Tip 	NF-TPMT630.5GD	NF-TPMT080202N-GD				●	.1875	.094	.0078	.090	S	0°	
	NF-TPMT630.5LD	NF-TPMT080202N-LD				●	.1875	.094	.0078	.090	S	0°	
	NF-TPMT631GD	NF-TPMT080204N-GD				●	.1875	.094	.0156	.090	S	0°	
	NF-TPMT631LD	NF-TPMT080204N-LD				●	.1875	.094	.0156	.090	S	0°	
	NF-TPMT1.81.50.5GD	NF-TPMT090202N-GD				●	.219	.094	.0078	.102	S	0°	
	NF-TPMT1.81.50.5LD	NF-TPMT090202N-LD				●	.219	.094	.0078	.102	S	0°	
	NF-TPMT1.81.51GD	NF-TPMT090204N-GD				●	.219	.094	.0156	.102	S	0°	
	NF-TPMT1.81.51LD	NF-TPMT090204N-LD				●	.219	.094	.0156	.102	S	0°	
	NF-TPMT21.50.5GD	NF-TPMT110202N-GD				●	.250	.094	.0078	.107	S	0°	
	NF-TPMT21.50.5LD	NF-TPMT110202N-LD				●	.250	.094	.0078	.107	S	0°	
	NF-TPMT21.51GD	NF-TPMT110204N-GD				●	.250	.094	.0156	.107	S	0°	
	NF-TPMT21.51LD	NF-TPMT110204N-LD				●	.250	.094	.0156	.107	S	0°	
	NF-TPMT220.5GD	NF-TPMT110302N-GD				●	.250	.125	.0078	.130	S	0°	
	NF-TPMT220.5LD	NF-TPMT110302N-LD				●	.250	.125	.0078	.130	S	0°	
	NF-TPMT221GD	NF-TPMT110304N-GD				●	.250	.125	.0156	.130	S	0°	
	NF-TPMT221LD	NF-TPMT110304N-LD				●	.250	.125	.0156	.130	S	0°	
	NF-TPMT222GD	NF-TPMT110308N-GD				●	.250	.125	.0312	.130	S	0°	
	NF-TPMT222LD	NF-TPMT110308N-LD				●	.250	.125	.0312	.130	S	0°	
	NF-TPMT330.5GD	NF-TPMT160402N-GD				●	.375	.1875	.0078	.1693	S	0°	
	NF-TPMT330.5LD	NF-TPMT160402N-LD				●	.375	.1875	.0078	.1693	S	0°	
	NF-TPMT331GD	NF-TPMT160404N-GD				●	.375	.1875	.0156	.1693	S	0°	
	NF-TPMT331LD	NF-TPMT160404N-LD				●	.375	.1875	.0156	.1693	S	0°	
	NF-TPMT332GD	NF-TPMT160408N-GD				●	.375	.1875	.0312	.1693	S	0°	
	NF-TPMT332LD	NF-TPMT160408N-LD				●	.375	.1875	.0312	.1693	S	0°	

TPMX

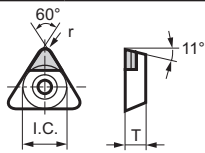

	Catalog No.	ISO Cat. No.	Stock				Dimensions					
			N				Inscribed Circle	Thickness	Nose Radius	Hole Diameter	Edge Preparation	Rake Angle
			DA90	DA150	DA1000	DA2200						
Standard Tip 	TPMX22V	TPMT110300				●	.250	.125	.0012	.130	S	0°
	TPMX220.5	TPMT110302				●	.250	.125	.0078	.130	S	0°
	TPMX221	TPMT110304				●	.250	.125	.0156	.130	S	0°
	TPMX222	TPMT110308				▲	.250	.125	.0313	.130	S	0°
	NF-TPMX220	NF-TPMT110301				●	.250	.125	.0039	.130	S	0°
NF-Tip	NF-TPMX220.5	NF-TPMT110302				●	.250	.125	.0078	.130	S	0°
	NF-TPMX221	NF-TPMT110304				●	.250	.125	.0156	.130	S	0°
	NF-TPMX222	NF-TPMT110308				●	.250	.125	.0313	.130	S	0°



Polycrystalline Diamond (PCD) Inserts

See page 583 for running parameters.

PCD

INSERTS - POSITIVE

VCMA • VCMT • VCMX

VC

35° Diamond Type

7° Relief

EDGE PREPARATIONS:

- | | | | |
|----|----------------------------------|---|-------------------------------|
| S | Standard | ● | USA Stocked Item |
| H | Honed | ★ | Worldwide Warehouse Item |
| K | Reinforced | ▲ | USA Limited Availability Item |
| AW | Chipbreaker Stud | ○ | Available 1st Quarter 2017 |
| WF | High Luster "Mirror-Like" Finish | | |

	VCMA	Catalog No.	ISO Cat. No.	Stock				Dimensions					
				DA90	DA150	DA1000	DA2200	Inscribed Circle	Thickness	Nose Radius	Hole Diameter	Edge Preparation	Rake Angle
Standard Tip		VCMA333	VCMW160412	▲				.375	.1875	.0469	.1732	S	0°
		VCMA333WF	VCMW160412WF	●				.375	.1875	.0469	.1732	WF	0°
		VCMA220520	VCMW220520					.500	.219	.3125	.1732	S	0°
		NF-VCMA332	NF-VCMW160408		●	●		.375	.1875	.0313	.1732	S	0°
NF Tip		NF-VCMA333	NF-VCMW160412					.375	.1875	.0469	.1732	S	0°
		NF-VCMA333H	NF-VCMW160412H					.375	.1875	.0469	.1732	H	0°

	VCMT with Chipbreaker	Catalog No.	ISO Cat. No.	Stock					Dimensions					
				DA90	DA150	DA2000	DA1000	DA2200	Inscribed Circle	Thickness	Nose Radius	Hole Diameter	Edge Preparation	Rake Angle
NF Tip		NF-VCMT220.5GD	NF-VCMT110302N-GD				●		.250	.125	.0078	.130	S	0°
		NF-VCMT220.5LD	NF-VCMT110302N-LD				●		.250	.125	.0078	.130	S	0°
		NF-VCMT221GD	NF-VCMT110304N-GD				●		.250	.125	.0156	.130	S	0°
		NF-VCMT221LD	NF-VCMT110304N-LD				●		.250	.125	.0156	.130	S	0°
		NF-VCMT331GD	NF-VCMT160404N-GD				●		.375	.1875	.0156	.1693	S	0°
		NF-VCMT331LD	NF-VCMT160404N-LD				●		.375	.1875	.0156	.1693	S	0°
		NF-VCMT332GD	NF-VCMT160408N-GD				●		.375	.1875	.0312	.1693	S	0°
		NF-VCMT332LD	NF-VCMT160408N-LD				●		.375	.1875	.0312	.1693	S	0°
		NF-VCMT333GD	NF-VCMT160412N-GD				●		.375	.1875	.0469	.1693	S	0°
		NF-VCMT333LD	NF-VCMT160412N-LD				●		.375	.1875	.0469	.1693	S	0°

	VCMX	Catalog No.	ISO Cat. No.	Stock				Dimensions					
				DA90	DA150	DA1000	DA2200	Inscribed Circle	Thickness	Nose Radius	Hole Diameter	Edge Preparation	Rake Angle
Standard Tip		VCMX333	VCMT160412				●	.375	.1875	.0469	.1732	S	10°
		VCMX333WF	VCMT160412WF				●	.375	.1875	.0469	.1732	WF	10°
NF Tip		NF-VCMX220	NF-VCMT110301				●	.250	.125	.0039	.134	S	10°
		NF-VCMX220.5	NF-VCMT110302				●	.250	.125	.0788	.134	S	10°
		NF-VCMX221	NF-VCMT110304				●	.250	.125	.0156	.134	S	10°
		NF-VCMX331	NF-VCMT160404				●	.375	.1875	.0156	.1732	S	10°
		NF-VCMX332	NF-VCMT160408				●	.375	.1875	.0313	.1732	S	10°
		NF-VCMX333	NF-VCMT160412				●	.375	.1875	.0469	.1732	S	10°



VP

35° Diamond Type

11° Relief

EDGE PREPARATIONS:

S Standard
 H Honed
 K Reinforced
 AW Chipbreaker Stud
 WF High Luster "Mirror-Like"
 Finish

- USA Stocked Item
- ★ Worldwide Warehouse Item
- ▲ USA Limited Availability Item
- Available 1st Quarter 2017

VPMA

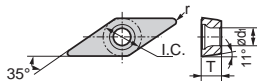

Catalog No.

ISO Cat. No.

	Stock				Dimensions					
	DA90	DA150	DA1000	DA2200	Inscribed Circle	Thickness	Nose Radius	Hole Diameter	Edge Preparation	Rake Angle
Standard Tip	VPMA443	VPMW220612		●	.500	.250	.0469	.214	S	0°
	VPMA443WF	VPMW220612WF		●	.500	.250	.0469	.214	WF	0°

WB

80° Trigon Type

5° Relief

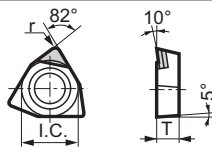

Catalog No.

ISO Cat. No.

	Stock				Dimensions					
	DA90	DA150	DA1000	DA2200	Inscribed Circle	Thickness	Nose Radius	Hole Diameter	Edge Preparation	Rake Angle
Standard Tip	WBMX520L	WBMT060101L		●	.156	.0625	.0039	.090	S	10°
	WBMX520.5L	WBMT060102L		●	.156	.0625	.0078	.090	S	10°
	WBMX521L	WBMT060104L		●	.156	.0625	.0156	.090	S	10°



Polycrystalline Diamond (PCD) Inserts

See page 583 for running parameters.

PCD

INSERTS - DOG-BONE

MDE

MDE

Dog Bone Type

for GDE Style Toolholders

EDGE PREPARATIONS:

- | | | | |
|----|----------------------------------|---|-------------------------------|
| S | Standard | ● | USA Stocked Item |
| H | Honed | ★ | Worldwide Warehouse Item |
| K | Reinforced | ▲ | USA Limited Availability Item |
| AW | Chipbreaker Stud | ○ | Available 1st Quarter 2017 |
| WF | High Luster "Mirror-Like" Finish | | |

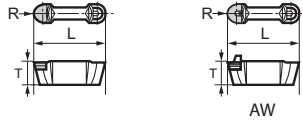
MDE			Stock				Dimensions					
			N				Inscribed Circle	Thickness	Nose Radius	Hole Diameter	Edge Preparation	Rake Angle
	Catalog No.	ISO Cat. No.	DA90	DA150	DA1000	DA2200						
Standard Tip	MDE3RN7	-				●	-	.335	.118	-	H	-7°
	MDE3RN7AW	-				●	-	.335	.118	-	AW	-7°
	MDE3RN7WF	-				▲	-	.335	.118	-	WF	-7°
	MDE3RN7AWWF	-				●	-	.335	.118	-	AW/WF	-7°
	MDE4RN7	-				●	-	.335	.157	-	H	-7°
	MDE4RN7AW	-				●	-	.335	.157	-	AW	-7°
	MDE4RN7WF	-				●	-	.335	.157	-	WF	-7°
	MDE4RN7AWWF	-				▲	-	.335	.157	-	AW/WF	-7°

Note: MDE inserts are held at a +7° rake angle by the GDER toolholder





SUMITOMO

CARBIDE - CBN - DIAMOND

1-800-950-5202

www.sumicarbide.com



TOOLHOLDERS	PAGES
Nomenclature.....	198-199
Insert Holding Method Overview.....	200
Sumitomo T-REX Holder Systems.....	201-202
D Type Toolholders.....	203-204
Toolholders for Ceramic Inserts.....	205-208
ANSI Standard Combination Toolholders.....	209-216

M

Insert Holding

D

Clamp Mechanism

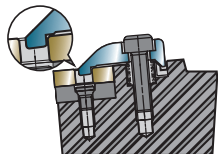

C

Clamp

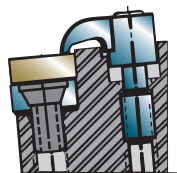

M

Clamp and Lock Pin

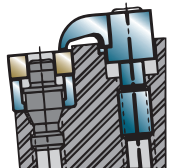

S

Screw Only

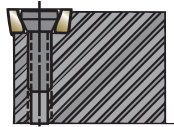

W

Wedge Clamp*

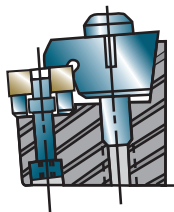

W

Insert Shape

C

Diamond



D

Diamond



R

Round

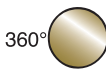

S

Square



T

Triangle



V

Diamond



W

Trigon



L

Toolholder Style



A

0° side cutting straight shank



C

0° end cutting straight shank



E

30° side cutting straight shank

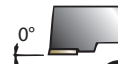

G

0° side cutting offset shank



K

15° end cutting offset shank

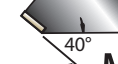

M

40° side cutting straight shank



Q

17°30' end cutting straight shank

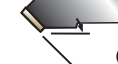

S

45° side cutting offset shank



V

17°30' side cutting straight shank

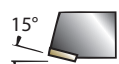

B

15° side cutting straight shank



D

45° side cutting straight shank



F

0° end cutting offset shank



J

-3° side cutting offset shank



L

5° side & end cutting offset shank



P

27°30' side cutting straight shank



R

15° side cutting offset shank



U

-3° end cutting offset shank

All lead angles are ±1°

N

Insert Relief Angle

B



5°

C



7°

N



0°

P



11°

*Sumitomo Standard Only



R

Hand

R
Right Hand

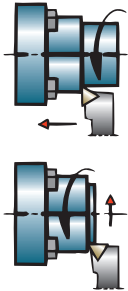

L
Left Hand

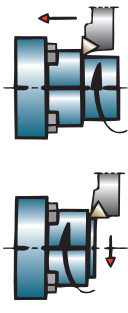

N
Neutral Hand

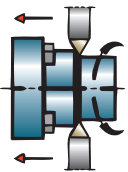

16

Shank Size

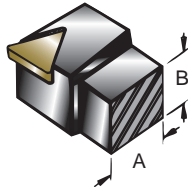

Square Shanks

This indicates the A & B dimensions in sixteenths (1/16).

examples:
 $12 = 12/16 = 3/4$ sq.
 $16 = 16/16 = 1.0$ sq.
 $20 = 20/16 = 1-1/4$ sq.

Rectangle Shanks

The first digit indicates the "A" dimension in eighths (1/8).

The second digit indicates the "B" dimension in quarters (1/4).

examples:
 $86 = A \times B$
 $1.0 \times 1-1/2$
 $85 = A \times B$
 $1.0 \times 1-1/4$

4

Insert Size

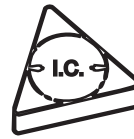

For equal sided inserts this indicates the inscribed circle (I.C.) in eighths (1/8)

examples,

$6 = 6/8 = 3/4$ " I.C.

$4 = 4/8 = 1/2$ " I.C.

$2.5 = 2.5/8 = 5/16$ I.C.

For rectangles and parallelograms two digits are necessary.

1st digit = number of eighths (1/8) in width.

2nd digit = number of quarters (1/4) in length.

D

Qualifications

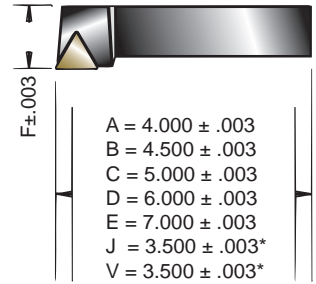

*Sumitomo standard only

Master Gage Insert Nose Radius Chart for Qualified Holders

Insert I.C.	Nose Radius
1/4, 5/16	.015
3/8, 1/2	.031
5/8, 3/4	.047
1.0	.062



Overview – Insert Holding Methods

T-Rex Toolholders

- Available in the -LU, -GU and -SU chipbreakers with grades T2000Z, AC700G, AC8025P, AC820P, AC830P, AC610M, and AC630M
- Rigid clamping system ensures accurate insert indexing
- Up to 2.5mm (0.100") depth of cut
- **Six** 55° cutting edges versus the standard **four** edges of a DNMG insert

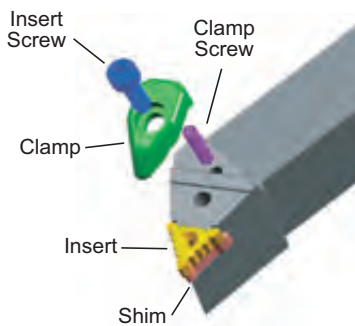

D Type Toolholders

- Stable clamp improves the fracture resistance of the insert
- Better machined workpiece accuracy with improved insert indexing precision
- Easy 1-step insert indexing

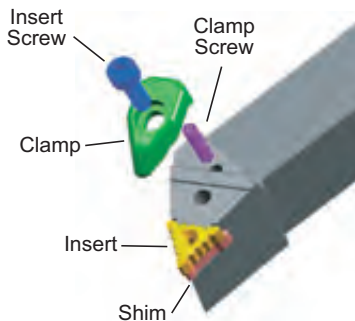

ANSI Standard Combination Toolholders

- A multiple-clamp and lock pin design for NC/CNC machines
- Maximum insert locking power with industry-standard NL lock pin mechanism
- Two different assembly options:
 1. for unground P-Type inserts
 2. for conventional precision-ground or utility-ground inserts with chipbreaker plates

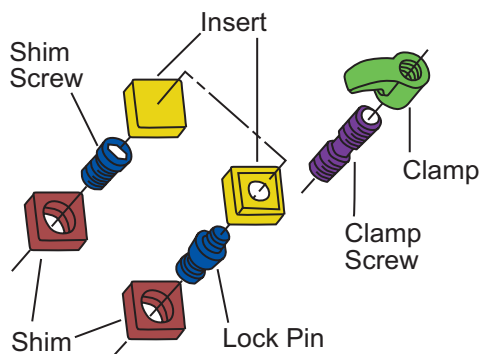

Wedge Clamp Toolholders

- Unique Sumitomo Standard multiple lock design.
- "Wedge Clamp" holding method also acts as pocket wall for Industry standard WNMG Inserts.
- Can be used for -5° end cutting and -5° side cutting applications.
- Available in 3/4" to 1-1/4" square shank sizes.

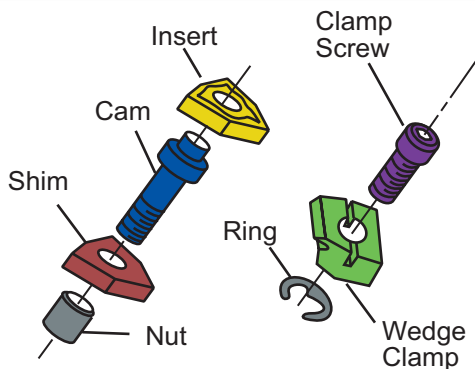

Screw-On Toolholders

- Qualified holders that conform to ISO-ANSI standards and utilize TORX® holding screws
- Shank sizes ranging from 3/8" to 1-1/2"
- Styles available for inserts with 5°, 7°, 11° clearance angles and advanced chip groove geometries

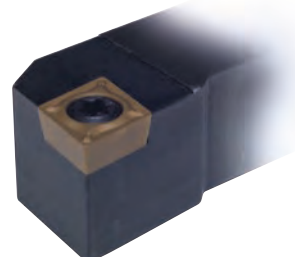
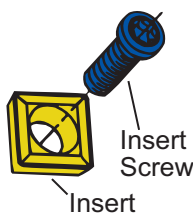

*TORX is a registered trademark of CamCar Division of Textron, Inc.





Replace your costly DNMG applications with the economical T-REX System!



Features & Benefits

- Available in the -LU, -GU and -SU chipbreakers with grades T2000Z, AC700G, AC8025P, AC820P, AC830P, AC610M, and AC630M
- Rigid clamping system ensures accurate insert indexing
- Up to 2.5mm (0.100") depth of cut
- **Six** 55° cutting edges versus the standard **four** edges of a DNMG insert



2.5mm (0.100")
Maximum
Depth of cut

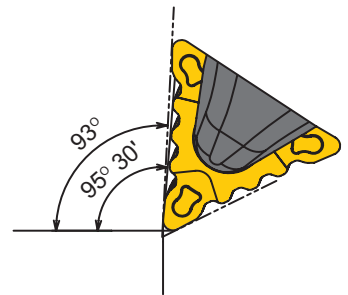

Grade Selection

Grade	Speed (SFM)		
	Steels	Stainless Steels	Gray Cast Irons
T2000Z	700 - 1400	600 - 900	-
AC700G	400 - 900	-	600 - 1200
AC610M	500 - 1000	400 - 700	-
AC6030M	200 - 800	300 - 700	-
AC810P	600 - 1200	-	-
AC8025P	300 - 800	-	-
AC830P	200 - 700	-	-

Chipbreaker Selection

Grade	Applications
-LU	Finish to medium cutting
-SU	Finish to medium cutting
-GU	General purpose cutting



Steels and Stainless Steels

AC700G
AC610M

AC8025P
AC6030M

AC830P

Continuous Cut Moderate Cut Interrupted Cut

Gray and Ductile Cast Irons

AC700G

AC820P

Continuous Cut Moderate Cut Interrupted Cut

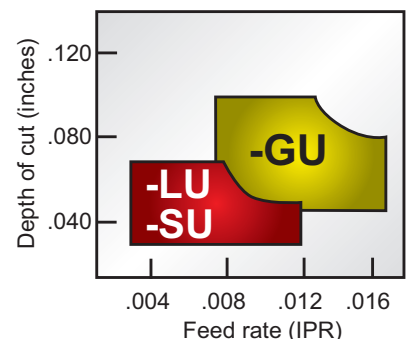

D TYPE TOOLHOLDERS

Series: DTR-C • DTR-Q

DTR Type Toolholders

T-REX Toolholder

DTR-C Series

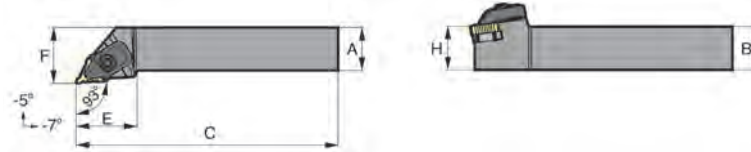

Sumitomo Cat. No.		Dimensions					
Right Hand	Left Hand	A	B	C	E	F	H
DTR55CR123B	DTR55CL123B	0.750"	0.750"	4.500"	1.375"	1.000"	0.750"
DTR55CR163D	DTR55CL163D	1.000"	1.000"	6.000"	1.375"	1.250"	1.000"
DTR55CR2525M17	DTR55CL2525M17	25.0mm	25.0mm	150.0mm	35.0mm	32.0mm	25.0mm

DTR-Q Series

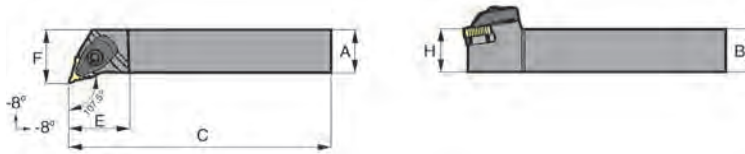

Sumitomo Cat. No.		Dimensions (Inch)					
Right Hand	Left Hand	A	B	C	E	F	H
DTR55QR163D	DTR55QL163D	1.000"	1.000"	6.000"	1.378"	1.260"	1.000"

T-REX Inserts

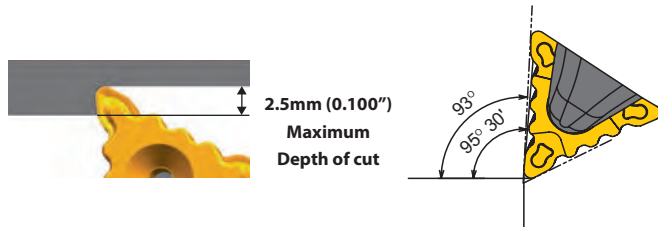

Please refer to page 70 for T-REX Inserts

Hardware

Clamp	Spring	Clamp Screw	Shim	Shim Screw	Wrench	Torx Wrench
TRCP3	SSP420	BX0520	TRW5505	BFTX0307N	TSW040	TRX10

Torque specifications for BX0520 clamp screw = 31-39 inch/lbs.



DCLN 95°

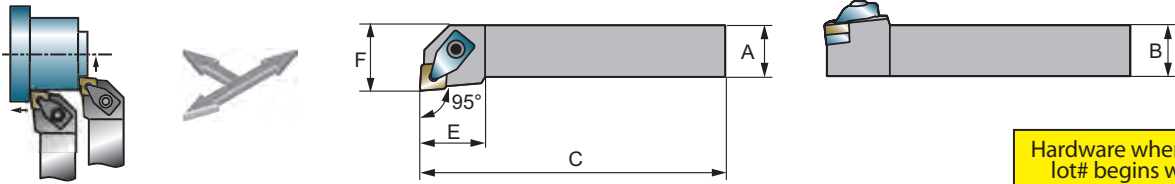

Catalog Number		Applicable Insert	A	B	C	E	F	Clamp	Spring	Clamp Screw	Shim	Shim Screw	Wrench	Hardware when Toolholder lot# begins with D####		
Right	Left													Clamp Spring Screw Set	Shim	Shim Screw
DCLNR124B	DCLNL124B	CN_43	.750	.750	4.50	1.250	1.000	CL-2312	SP-4295	CLB-1907	ICSN433	ST-1160	LH040	SCP-2	CNS1204	BFTX0409N
DCLNR164D	DCLNL164D	CN_43	1.000	1.000	6.00	1.250	1.250							N/A	N/A	N/A
DCLNR204D	DCLNL204D	CN_43	1.250	1.250	6.00	1.250	1.500	CL-2318			ICSN533	ST-1180		N/A	N/A	N/A
DCLNR205D	DCLNL205D	CN_54	1.250	1.250	6.00	1.375	1.500									
DCLNR245E	DCLNL245E	CN_54	1.500	1.500	7.00	1.375	2.000									

DDJ Series

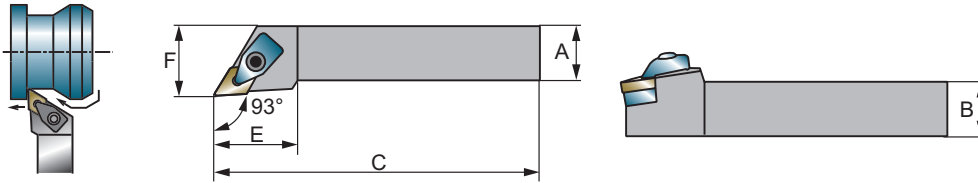

Catalog Number		Applicable Insert	A	B	C	E	F	Clamp	Spring	Clamp Screw	Shim	Shim Screw	Wrench	Hardware when Toolholder lot# begins with D####		
Right	Left													Clamp Spring Screw Set	Shim	Shim Screw
DDJNR124B	DDJNL124B	DNMG43-	.750	.750	4.50	1.535	1.000	CL-2312	SP-4295	CLB-1907	DNS1504	ST-1160	LH040	SCP-2	DNS1504	BFTX0409N
DDJNR164D	DDJNL164D	DNMG43-	1.000	1.000	6.00	1.535	1.250									

DTF Series

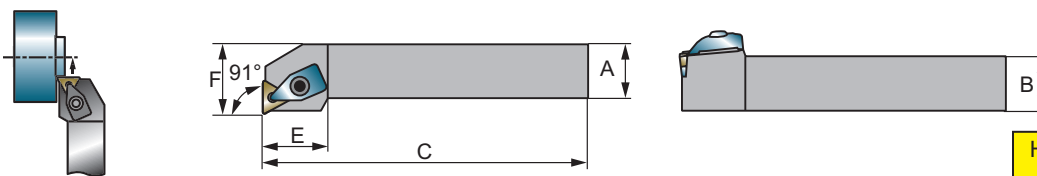

Catalog Number		Applicable Insert	A	B	C	E	F	Clamp	Spring	Clamp Screw	Shim	Shim Screw	Wrench	Hardware when Toolholder lot# begins with D####		
Right	Left													Clamp Spring Screw Set	Shim	Shim Screw
DTFNR123B	DTFNL123B	TNMG33-	.750	.750	4.50	1.000	1.000	CL-2308	SP-4295	CLB-1915	ITSN323	ST-1150	LH025	SCP-1	TNS1604	BFTX0307N
DTFNR163D	DTFNL163D	TNMG33-	1.000	1.000	6.00	1.000	1.250									



DTG Series

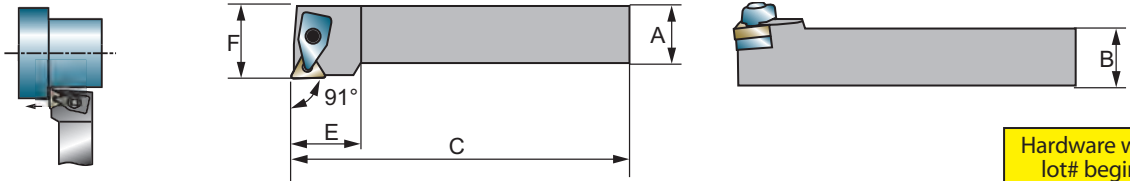

Catalog Number		Applicable Insert	A	B	C	E	F	Clamp	Spring	Clamp Screw	Shim	Shim Screw	Wrench	Hardware when Toolholder lot# begins with D####		
Right	Left													Clamp Spring Screw Set	Shim	Shim Screw
DTGNR123B	DTGNL123B	TNMG33-	.750	.750	4.50	1.102	1.000	CL-2308	SP-4295	CLB-1915	ITSN323	ST-1150	LH025	SCP-1	TNS1604	BFTX0307N
DTGNR163D	DTGNL163D		1.000	1.000	6.00	1.102	1.250									

DWL Series

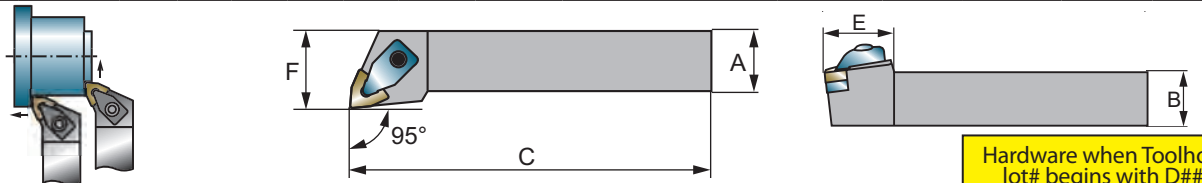

Catalog Number		Applicable Insert	A	B	C	E	F	Clamp	Spring	Clamp Screw	Shim	Shim Screw	Wrench	Hardware when Toolholder lot# begins with D####		
Right	Left													Clamp Spring Screw Set	Shim	Shim Screw
DWLN123B	DWLN123B	WNMG33-	.750	.750	4.50	1.000	1.000	SCP-4			IWSN322	S-34	LH020	N/A		
DWLN124B	DWLN124B	WNMG43-	.750	.750	4.50	1.250	1.000	CL-2312	SP-4295	CLB-1907	IWSN433	ST-1160	LH040	SCP-2	WNS0804	BFTX0409N
DWLN163D	DWLN163D	WNMG33-	1.000	1.000	6.00	1.000	1.250	SCP-4			IWSN322	S-34	LH020	N/A		
DWLN164D	DWLN164D	WNMG43-	1.000	1.000	6.00	1.250	1.250	CL-2312	SP-4295	CLB-1907	IWSN433	ST-1160	LH040	SCP-2	WNS0804	BFTX0409N



ANSI Combination Toolholders

Toolholders for Ceramic Inserts

ANSI COMBINATION

TOOLHOLDERS

Series: CCKN-CD • CCKN-CX • CCLN-CD

Toolholders

CCKN-CD

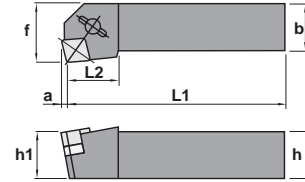
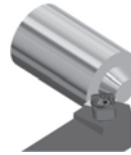

Catalog Number		Applicable Insert	b	h	h ₁	L ₁	L ₂	f	a	Shim	Screw	Chipbreaker	Clamp	Wrench
Right	Left													
CCKNR164CD	CCKNL164CD	CNG45_	1.000	1.000	1.000	6.000	1.338	1.250	0.122	ICSN434	BXD06135	CBCR45	CLCD45	LH040
CCKNR204CD	CCKNL204CD	CNMN45_	1.250	1.250	1.250			1.500						

CCKN-CX

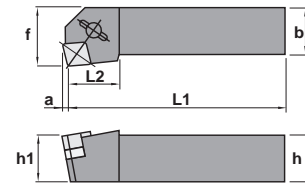
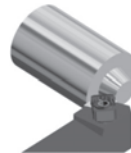

Catalog Number		Applicable Insert	b	h	h ₁	L ₁	L ₂	f	a	Shim	Screw	Chipbreaker	Clamp	Wrench
Right	Left													
CCKNR164CX	CCKNL164CX	CNGX45_	1.000	1.000	1.000	6.000	1.338	1.250	0.122	ICSN434	BXD06135	CBCR45	CLCX45	LH040
CCKNR204CX	CCKNL204CX		1.250	1.250	1.250			1.500						

CCLN-CD

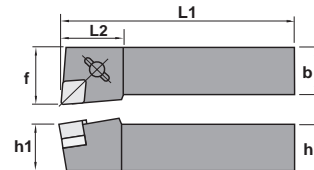
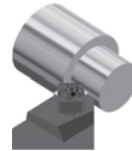

Catalog Number		Applicable Insert	b	h	h ₁	L ₁	L ₂	f	Shim	Screw	Chipbreaker	Clamp	Wrench
Right	Left												
CCLNR164CD	CCLNL164CD	CNG45_	1.000	1.000	1.000	6.000	1.338	1.250	ICSN434	BXD06135	CBCR45	CLCD45	LH040
CCLNR204CD	CCLNL204CD	CNMN45_	1.250	1.250	1.250			1.500					



ANSI COMBINATION TOOLHOLDERS

Series: CCLN-CX • CDJN-CX • CRDC-CD

ANSI Combination Toolholders

Toolholders for Ceramic Inserts

Toolholders

Catalog Number		Applicable Inserts	b	h	h ₁	L ₁	L ₂	f	Shim	Screw	Chipbreaker	Clamp	Wrench
Right	Left												
CCLNR164CX	CCLNL164CX	CNGX45_	1.000	1.000	1.000	6.000	1.338	1.250	ICSN434	BXD06135	CBCR45	CLCX44	LH040
CCKNR204CX	CCLNL204CX		1.250	1.250	1.250			1.500					

Catalog Number		Applicable Inserts	b	h	h ₁	L ₁	L ₂	f	Shim	Screw	Chipbreaker	Clamp	Wrench
Right	Left												
CDJNR164CX	CDJNL164CX	DNGX45_	1.000	1.000	1.000	6.000	1.496	1.250	IDSN434	BXD06135	-	CLCXD45	LH040
CDJNR204CX	CDJNL204CX		1.250	1.250	1.250			1.500					

Catalog Number	Applicable Insert	b	h	h ₁	L ₁	L ₂	f	Seat Screw	Seat	Clamp	Clamp Screw	Wrench	Wrench
Neutral													
CRDCN163CD	RCGX35	1.000	1.000	1.000	6.000	1.420	0.500	BFTX0315	IRSC35	CLCDRC34	BFTX0520	TRX15	LH030
CRDCN203CD		1.250	1.250	1.250			0.625						
CRDCN164CD	RCGX45	1.000	1.000	1.000	1.300	0.500	BFTX0520	IRSC45	CLCDRC45	BFTX0309	TRX20		
CRDCN204CD		1.250	1.250	1.250								0.625	



CRDN-CD

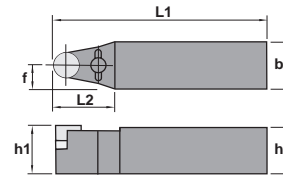

Catalog Number			b	h	h ₁	L ₁	L ₂	f					
Neutral	-	Applicable Insert							Shim	Screw	Chipbreaker	Clamp	Wrench
CRDNN164CD	-	RNG45	1.000	1.000	1.000	6.000	1.500	0.500	IRSN43	BXD06135	CBCR45	CLCD45	LH040
CRDNN205CD	-	RNG55	1.250	1.250	1.250		1.417	0.625	IRSN53	BXD08135			
CRDNN245CD	-	RNG55	1.500	1.500	1.500		0.750						

CRGN-CD

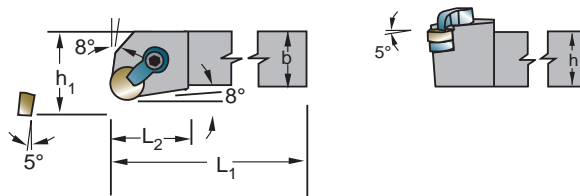

Catalog Number			b	h	h ₁	L ₁	L ₂	f					
Right	Left	Applicable Insert							Shim	Screw	Chipbreaker	Clamp	Wrench
CRGNN124CD	-	RNG45	.750	.750	.750	4.500	1.250	1.000	IRSN-43	BXD06135	CBCR45	CLCDRN55	LH040
CRGNN164CD	CRGNL164CD		1.000	1.000	1.000	6.000	1.338	1.250					
CRGNN204CD	CRGNR204CD		1.250	1.250	1.250			1.500					
CRGNN165CD	CRGNL165CD	1.000	1.000	1.000	IRSN53			BXD08135	1.250				
CRGNN205CD	CRGNL205CD	1.250	1.250	1.250		1.500							

CSDN-CX

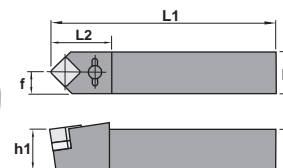

Catalog Number		b	h	h ₁	L ₁	L ₂	f					
Right	Applicable Insert							Shim	Screw	Chipbreaker	Clamp	Wrench
CSDNN164CX	SNMX45	1.000	1.000	1.000	6.000	1.653	0.500	ISSN434	BXD06135	-	CLCX44	LH040
CSDNN204CX		1.250	1.250	1.250			0.625					

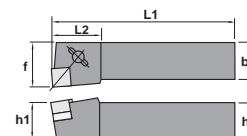
CSKN-CX

Catalog Number			b	h	h ₁	L ₁	L ₂	f					
Right	Left	Applicable Insert							Shim	Screw	Chipbreaker	Clamp	Wrench
CSKNR164CX	CSKNL164CX	SNMX45	1.000	1.000	1.000	6.000	1.338	1.250	ISSN434	BXD06135	-	CLCX44	LH040
CSKNR204CX	CSKNL204CX		1.250	1.250	1.250								

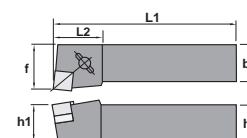
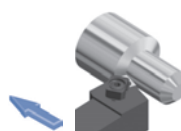
CSRN-CX

Catalog Number			b	h	h ₁	L ₁	L ₂	f					
Right	Left	Applicable Insert							Shim	Screw	Chipbreaker	Clamp	Wrench
CSRNR164CX	CSRNL164CX	SNMX45	1.000	1.000	1.000	6.000	1.338	1.130	ISSN434	BXD06135	-	CLCX44	LH040
CSRNR204CX	CSRNL204CX		1.250	1.250	1.250			1.379					

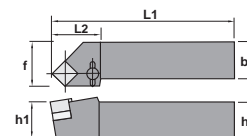
CSSN-CX

Catalog Number			b	h	h ₁	L ₁	L ₂	f					
Right	Left	Applicable Insert							Shim	Screw	Chipbreaker	Clamp	Wrench
CSSNR164CX	CSSNL164CX	SNMX45	1.000	1.000	1.000	6.000	1.653	1.250	ISSN434	BXD06135	-	CLCX44	LH040
CSSNR204CX	CSSNL204CX		1.250	1.250	1.250			1.500					

MCGN 90°



Catalog Number		Applicable Insert	A	B	C	D	F	Shim	Lock Pin	Clamp	Clamp Screw	Shim Screw	Wrench	Wrench
Right	Left													
MCGNR124B	MCGNL124B	CN__43	.750	.750	4.50	1.120	1.000							
MCGNR164D	MCGNL164D	CN__43	1.000	1.000	6.00	1.120	1.250	ICSN433	NL46	CL-20	XNS48	S46	LH3/32	LH030
MCGNR204D	MCGNL204D	CN__43	1.250	1.250	6.00	1.120	1.500							
MCGNL165D	MCGNR165D	CN__54	1.00	1.000	6.00	1.500	1.250	ICSN533	NL58	CL-12	XNS510	S58	LH030	LH040
MCGNR205D	MCGNL205D	CN__54	1.250	1.250	6.00	1.500	1.500							
MCGNR206D	MCGNL206D	CN__64	1.250	1.250	6.00	1.650	1.500	ICSN633	NL68					

MCK Series

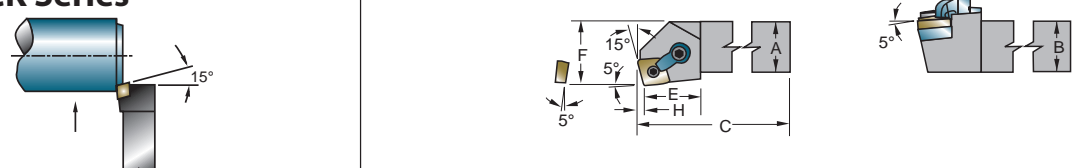

Sumitomo Cat. No.		Applicable Insert	A	B	C	E	F	H	Shim	Lock Pin	Clamp	Clamp Screw	Shim Screw	Wrench	Wrench
Right Hand	Left Hand														
MCKNR124B	MCKNL124B	CNMG43-	.750	.750	4.500	1.20	1.000	.123	ICSN433	NL46	CL20	XNS48	S46	LH3/32	LH030
MCKNR164D	MCKNL164D	CNMG43-	1.000	1.000	6.000	1.20	1.250	.123	ICSN433	NL46	CL20	XNS48	S46	LH3/32	LH030
MCKNR206D	MCKNL206D	CNMG64-	1.250	1.250	6.000	1.47	1.500	.184	ICSN633	NL68	CL12	XNS510	S68	LH040	LH040

MCL Series

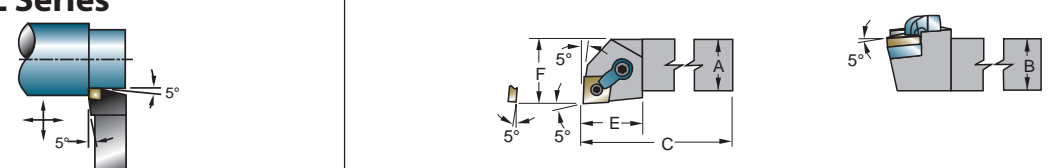

Sumitomo Cat. No.		Applicable Insert	A	B	C	E	F	Shim	Lock Pin	Clamp	Clamp Screw	Shim Screw	Wrench	Wrench
Right Hand	Left Hand													
MCLNR083A	MCLNL083A	CNMG32-	.500	.500	4.000	1.000	.750	N/A	NL-33	CL-6	XNS-37	-	-	-
MCLNR103A	MCLNL103A	CNMG32-	.625	.625	4.000	1.000	.875	N/A	NL-33	CL-6	XNS-37	-	-	-
MCLNR123B	MCLNL123B	CNMG32-	.750	.750	4.500	1.000	1.000	ICSN-322	NL-34L	CL-6	XNS-37	S-34	-	-
MCLNR124B	MCLNL124B	CNMG43-	.750	.750	4.500	1.130	1.000	ICSN433	NL46	CL20	XNS48	S46	LH3/32	LH030
MCLNR164C	MCLNL164C	CNMG43-	1.000	1.000	5.000	1.250	1.250	ICSN433	NL46	CL20	XNS48	S46	LH3/32	LH030
MCLNR164D	MCLNL164D	CNMG43-	1.000	1.000	6.000	1.130	1.250	ICSN433	NL46	CL20	XNS48	S46	LH3/32	LH030
MCLNR165D	MCLNL165D	CNMG54-	1.000	1.000	6.000	1.470	1.250	ICSN533	NL58	CL12	XNS510	S58	LH040	LH030
MCLNR166D	MCLNL166D	CNMG64-	1.000	1.000	6.000	1.510	1.250	ICSN633	NL68	CL12	XNS510	S68	LH9/64	LH040
MCLNR204D	MCLNL204D	CNMG43-	1.250	1.250	6.000	1.130	1.500	ICSN433	NL46	CL20	XNS48	S46	LH3/32	LH030
MCLNR205D	MCLNL205D	CNMG54-	1.250	1.250	6.000	1.470	1.500	ICSN533	NL58	CL12	XNS510	S58	LH040	LH030
MCLNR206D	MCLNL206D	CNMG64-	1.250	1.250	6.000	1.510	1.500	ICSN633	NL68	CL12	XNS510	S68	LH9/64	LH040
MCLNR244D	MCLNL244D	CNMG43-	1.500	1.500	6.000	1.250	2.000	ICSN433	NL46	CL20	XNS48	S46	LH3/32	LH030
MCLNR245E	MCLNL245E	CNMG54-	1.500	1.500	7.000	1.375	2.000	ICSN533	NL58	CL12	XNS510	S58	LH040	LH030
MCLNR246E	MCLNL246E	CNMG64-	1.500	1.500	7.000	1.500	2.000	ICSN633	NL68	CL12	XNS510	S68	LH9/64	LH040

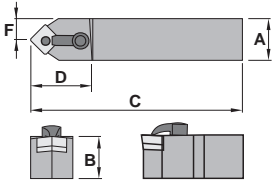

MCMN 50°

Catalog Number	Applicable Insert	A	B	C	D	Shim	Lock Pin	Clamp	Clamp Screw	Shim Screw	Wrench	Wrench
MCMNN124B	CN__43	.750	.750	4.50	1.280							
MCMNN164D	CN__43	1.000	1.000	6.00	1.280	ICSN433	NL46	CL20	XNS48	S46	LH3/32	LH030
MCMNN204D	CN__43	1.250	1.250	6.00	1.390							
MCMNN165D	CN__54	1.00	1.000	6.00	1.750	ICSN533	NL58	CL12	XNS510	S58	LH030	LH040
MCMNN205D	CN__54	1.250	1.250	6.00	1.610						-	

MCR Series

OPTIONAL HARDWARE

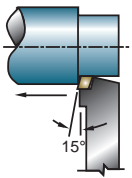
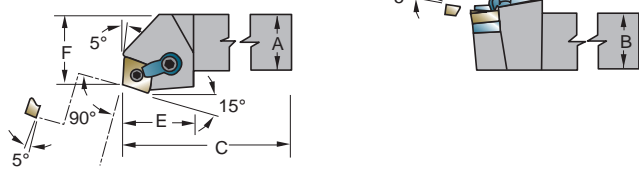
Sumitomo Cat. No.		Applicable Insert	A	B	C	E	F	Shim	Lock Pin	Clamp	Clamp Screw	Shim Screw	Wrench	Wrench
Right Hand	Left Hand													
MCRNR124B	MCRNL124B	CNMG43-	.750	.750	4.500	1.180	.750	ICSN433	NL46	CL20	XNS48	S46	LH3/32	LH030
MCRNR164D	MCRNL164D	CNMG43-	1.000	1.000	6.000	1.180	1.250	ICSN433	NL46	CL20	XNS48	S46	LH3/32	LH030
MCRNR204D	MCRNL204D	CNMG43-	1.250	1.250	6.000	1.180	1.500	ICSN433	NL46	CL20	XNS48	S46	LH3/32	LH030
MCRNR246E	MCRNL246E	CNMG64-	1.500	1.500	7.000	1.500	2.000	ICSN633	NL68	CL12	XNS510	S68	LH9/64	LH040

MDJN 93°

Catalog Number		Applicable Insert	A	B	C	D	F	Shim	Lock Pin	Clamp	Clamp Screw	Shim Screw	Wrench	Wrench
Right	Left													
MDJNR083A	MDJNL083A	DN__33	.500	.500	4.00	1.062	.625							
MDJNR103B	MDJNL103B	DN__33	.625	.625	4.50	1.250	.875							
MDJNR123B	MDJNL123B	DN__33	.750	.750	4.50	1.250	1.000			CL7	XNS36			LH020
MDJNR163D	MDJNL163D	DN__33	1.000	1.000	6.00	1.250	1.250							
MDJNR124B	MDJNL124B	DN__43	.750	.750	4.50	1.500	1.000							
MDJNR164C	MDJNL164C	DN__43	1.000	1.000	5.00	1.250	1.250							
MDJNR164D	MDJNL164D	DN__43	1.000	1.000	6.00	1.500	1.250	IDSN433	NL46	CL20	XNS48	S46		LH030
MDJNR204D	MDJNL204D	DN__43	1.250	1.250	6.00	1.500	1.500							

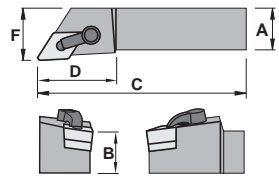

MDPN 62° 30'

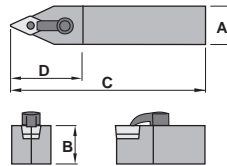
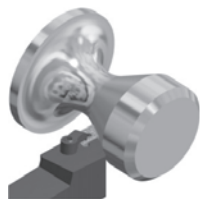

Catalog Number	Applicable Insert	A	B	C	D	Shim	Lock Pin	Clamp	Clamp Screw	Shim Screw	Wrench	Wrench
MDPNN123B	DN_ 33	.750	.750	4.50	1.620	-	NL34L	CL7	XNS36	-		LH020
MDPNN124B	DN_ 43	.750	.750	4.50	1.620	IDSN433	NL-46	CL-22	XNS48	S46	LH3/32	LH030
MDPNN164D	DN_ 43	1.00	1.00	6.00	1.620			CL20				
MDPNN204D	DN_ 43	1.250	1.250	6.00	1.620							

MDQ Series

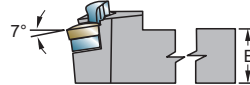
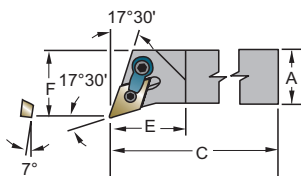
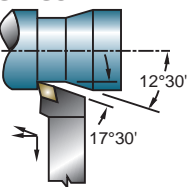

Sumitomo Cat. No.		Applicable Insert	A	B	C	E	F	Shim	Lock Pin	Clamp	Clamp Screw	Shim Screw	Wrench	Wrench	OPTIONAL HARDWARE
Right Hand	Left Hand														
MDQNR124B	MDQNL124B	DNMG43-	.750	.750	4.500	1.370	1.000	IDSN433	NL46	CL20	XNS48	S46	LH3/32	LH030	
MDQNR164C	MDQNL164C	DNMG43-	1.000	1.000	5.000	1.370	1.250	IDSN433	NL46	CL20	XNS48	S46	LH3/32	LH030	
MDQNR164D	MDQNL164D	DNMG43-	1.000	1.000	6.000	1.370	1.250	IDSN433	NL46	CL20	XNS48	S46	LH3/32	LH030	
MDQNR204D	MDQNL204D	DNMG43-	1.250	1.250	6.000	1.370	1.500	IDSN433	NL46	CL20	XNS48	S46	LH3/32	LH030	

MRG Series

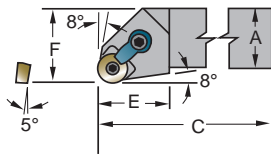
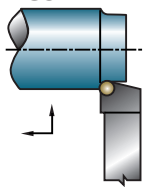

Sumitomo Cat. No.		Applicable Insert	A	B	C	E	F	Shim	Lock Pin	Clamp	Clamp Screw	Shim Screw	Shim	Wrench	Wrench	OPTIONAL HARDWARE
Right Hand	Left Hand															
MRGNR124B	MRGNL124B	RNMG43	.750	.750	4.500	1.060	1.000	IRSN43	NL46	CL20	XNS48	S46	IRSN-44	LH3/32	LH030	
MRGNR164D	MRGNL164D	RNMG43	1.000	1.000	6.000	1.060	1.250	IRSN43	NL46	CL20	XNS48	S46	IRSN-44	LH3/32	LH030	
MRGNR204D	MRGNL204D	RNMG43	1.250	1.250	6.000	1.060	1.500	IRSN43	NL46	CL20	XNS48	S46	IRSN-44	LH3/32	LH030	



MSD Series							OPTIONAL HARDWARE								
Sumitomo Cat. No.			A	B	C	E	F								
Neutral Hand		Applicable Insert						Shim	Lock Pin	Clamp	Clamp Screw	Shim Screw	Shim	Wrench	Wrench
MSDNN124B		SNMG43-	.750	.750	4.500	1.300	.375	ISSN433	NL46	CL20	XNS48	S46	ISSN-443	LH3/32	LH030
MSDNN164D		SNMG43-	1.000	1.000	6.000	1.300	.500	ISSN433	NL46	CL20	XNS48	S46	ISSN-443	LH3/32	LH030

MSR Series								OPTIONAL HARDWARE							
Sumitomo Cat. No.			A	B	C	E	F								
Right Hand	Left Hand	Applicable Insert						Shim	Lock Pin	Clamp	Clamp Screw	Shim Screw	Shim	Wrench	Wrench
MSRNR124B	MSRNL124B	SNMG43-	.750	.750	4.500	1.250	.880	ISSN433	NL46	CL20	XNS48	S46	ISSN-443	LH3/32	LH030
MSRNR164D	MSRNL164D	SNMG43-	1.000	1.000	6.000	1.250	1.130	ISSN433	NL46	CL20	XNS48	S46	ISSN-443	LH3/32	LH030
MSRNR205D	MSRNL205D	SNMG54-	1.250	1.250	6.000	1.500	1.353	ISSN533	NL58	CL12	XNS510	S58	ISSN-543	LH040	LH030
MSRNR206D	MSRNL206D	SNMG64-	1.250	1.250	6.000	1.590	1.321	ISSN633	NL68	CL12	XNS610	S68	ISSN-643	LH9/64	LH040

MSSN 45°							OPTIONAL HARDWARE							
Catalog Number			A	B	C	D	F							
Right	Left	Applicable Insert						Shim	Lock Pin	Clamp	Clamp Screw	Shim Screw	Wrench	Wrench
MSSNR124B	MSSNL124B	SNM_43	.750	.750	4.50	1.230	.675	ISSN433	NL46	CL20	XNS48	S46	LH3/32	LH030
MSSNR164D	MSSNL164D	SNM_43	1.000	1.000	6.00	1.230	.925							
MSSNR165D	MSSNL165D	SNM_54	1.000	1.000	6.00	1.380	.847	ISSN533	NL58	CL12	XNS510	S58	LH040	LH030
MSSNR205D	MSSNL205D	SNM_54	1.250	1.250	6.00	1.380	1.097							
MSSNR206D	MSSNL206D	SNM_64	1.250	1.250	6.00	1.470	1.011	ISSN633	NL68	CL12	XNS610	S68	LH9/64	LH040
MSSNR246E	MSSNL246E	SNM_64	1.500	1.500	7.00	1.470	1.511							



MTAN 90°



Catalog Number		Applicable Insert	A	B	C	D	F	Shim	Lock Pin	Clamp	Clamp Screw	Shim Screw	Wrench	Wrench	Optional Shim
Right	Left														
MTANR082A	MTANL082A	TN__22	.500	.500	4.00	.875	.500	-	NL-23	CL7	XNS-34	-	LH3/32	LH1/16	-
MTANR103B	MTANL103B	TN__32	.625	.625	4.50	1.000	1.000	ITSN323	NL34L	CL20	XNS48	S34	LH020	LH030	ITSN333
MTANR123B	MTANL123B	TN__33	.750	.750	4.50	1.060	.750								-
MTANR163D	MTANL163D	TN__33	1.000	1.00	6.00	1.060	1.000								-
MTANR164D	MTANL164D	TN__43	1.000	1.000	6.00	1.220	1.000	ITSN433	NL46	-	-	S46	LH3/32	-	-

MTENN(S) 60°

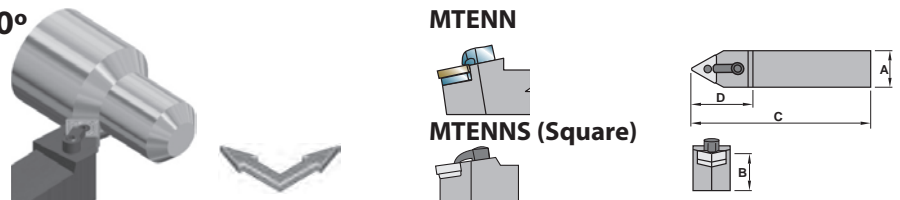

MTENN
MTENNS (Square)

Catalog Number	Applicable Insert	A	B	C	D	F	Shim	Lock Pin	Clamp	Clamp Screw	Shim Screw	Wrench	Wrench
MTENN082A	TN__22	.500	.500	4.000	1.000	.250	-	NL23	CL7	XNS-34	-	LH3/32	LH1/16
MTENN103B	TN__32	.625	.625	4.500	1.125	.312	ITSN323	NL34L	CL20	XNS48	S34	LH020	LH030
MTENN123B	TN__32	.750	.750	4.500	1.125	.375					-		
MTENNS163D	TN__33	1.000	1.000	6.000	1.500	.500					-	S46	LH3/32
MTENN164D	TN__43	1.000	1.000	6.000	1.500	.500	ITSN433	-	-	S34	LH020	LH030	
MTENN205D	TN__54	1.250	1.250	6.000	1.625	.625	ITSN533	NL58	CL12	XNS510	S58	LH040	LH030
MTENN205E	TN__54	1.250	1.250	6.00	1.620	.625							

MTGN 90°



Catalog Number		Applicable Insert	A	B	C	D	F	Shim	Lock Pin	Clamp	Clamp Screw	Shim Screw	Wrench	Wrench	
Right	Left														
MTGNR103B	MTGNL103B	TN__32	.625	.625	4.50	1.000	.875	ITSN323	NL34L	CL20	XNS48	S34	LH020	LH030	
MTGNR123B	MTGNL123B	TN__32	.750	.750	4.50	1.060	1.000								-
MTGNR163D	MTGNL163D	TN__33	1.000	1.000	6.00	1.060	1.250								-
MTGNR164D	MTGNL164D	TN__43	1.000	1.000	6.00	1.220	1.250	ITSN433	NL46	-	-	S46	LH3/32	LH030	

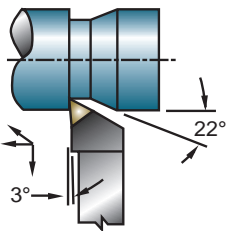
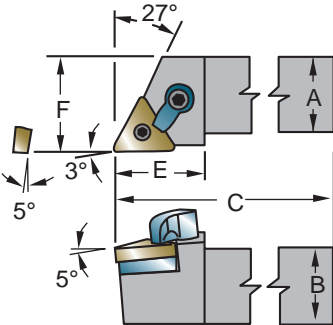
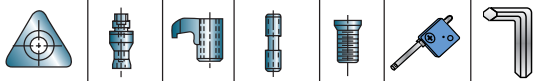

MTJ Series								OPTIONAL HARDWARE						
														
Sumitomo Cat. No.		Applicable Insert	A	B	C	E	F	Shim	Lock Pin	Clamp	Clamp Screw	Shim Screw	Wrench	Wrench
Right Hand	Left Hand													
MTJNR123B	MTJNL123B	TNMG32-	.750	.750	4.500	1.030	1.000	ITSN323	NL34L	CL20	XNS48	S34	LH020	LH030
MTJNR124B	-	TNMG43-	.750	.750	4.500	1.190	1.000	ITSN433	NL46	CL20	XNS48	S46	LH3/32	LH030
MTJNR163D	MTJNL163D	TNMG32-	1.000	1.000	6.000	1.030	1.250	ITSN323	NL34L	CL20	XNS48	S34	LH020	LH030
MTJNR164D	MTJNL164D	TNMG43-	1.000	1.000	6.000	1.250	1.250	ITSN433	NL46	CL20	XNS48	S46	LH3/32	LH030
-	MTJNL204D	TNMG43-	1.250	1.250	6.000	1.250	1.500	ITSN433	NL46	CL20	XNS48	S46	LH3/32	LH030
MTJNR204E	MTJNL204E	TNMG43-	1.250	1.250	7.000	1.190	1.250	ITSN433	NL46	CL20	XNS48	S46	LH3/32	LH030

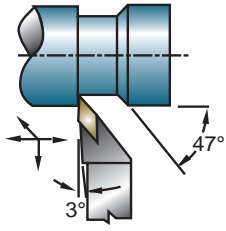
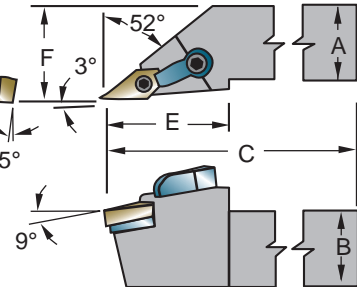
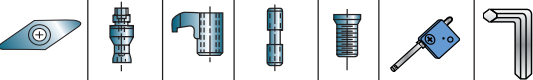
MVJ Series								OPTIONAL HARDWARE						
														
Sumitomo Cat. No.		Applicable Insert	A	B	C	E	F	Shim	Lock Pin	Clamp	Clamp Screw	Shim Screw	Wrench	Wrench
Right Hand	Left Hand													
MVJNR123B	MVJNL123B	VNMG33-	.750	.750	4.500	1.620	1.000	IVSN322	NL34L	CL-22	XNS48	S34	LH020	LH030
MVJNR163D	MVJNL163D	VNMG33-	1.000	1.000	6.000	1.620	1.250	IVSN322	NL34L	CL-22	XNS48	S34	LH020	LH030
MVJNR164C	MVJNL164C	VNMG43-	1.000	1.000	5.000	2.125	1.250	IVSN433	NL46	CL30	XNS510	S46	LH3/32	LH040
MVJNR164D	MVJNL164D	VNMG43-	1.000	1.000	6.000	1.880	1.250	IVSN433	NL46	CL30	XNS510	S46	LH3/32	LH040
MVJNR203D	MVJNL203D	VNMG33-	1.250	1.250	6.000	1.750	1.500	IVSN322	NL34L	CL-22	XNS48	S34	LH020	LH030
MVJNR204D	MVJNL204D	VNMG43-	1.250	1.250	6.000	1.880	1.500	IVSN433	NL-46	CL30	XNS510	S46	LH3/32	LH040









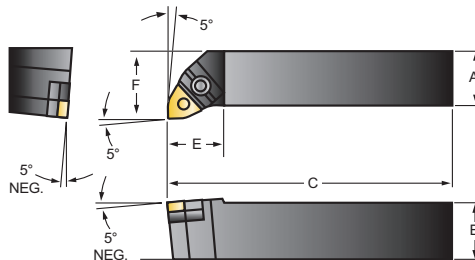
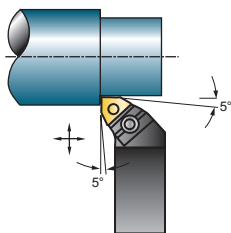

MVV Series														OPTIONAL HARDWARE	
Sumitomo Cat. No.		A	B	C	E	F									
Neutral Hand	Applicable Insert						Shim	Lock Pin	Clamp	Clamp Screw	Shim Screw	Wrench	Wrench		
MVVNN123B	VNMG33-	.750	.750	4.500	1.620	.375	IVSN322	NL34L	CL-22	XNS48	S34	LH020	LH030		
MVVNN163D	VNMG33-	1.000	1.000	6.000	1.620	.500	IVSN322	NL34L	CL-22	XNS48	S34	LH020	LH030		
MVVNN164D	VNMG43-	1.000	1.000	6.000	2.060	.500	IVSN433	NL46	CL30	XNS510	S46	LH3/32	LH030		

MWLN 95°														
Catalog Number			A	B	C	D	F							
Right	Left	Applicable Insert						Shim	Lock Pin	Clamp	Clamp Screw	Shim Screw	Wrench	Wrench
MWLN123B	MWLN123B	WN__33	.750	.750	4.50	1.000	1.000	IWSN322		CL6	XNS-36	-		LH020
MWLN163C	MWLN163C	WN__33	1.000	1.000	5.00	1.000	1.250							
MWLN163D	MWLN163D	WN__33	1.000	1.000	6.00	1.000	1.250							
MWLN243D	MWLN243D	WN__33	1.500	1.500	6.00	1.000	2.000	IWSN433	NL46	CL20	XNS48	S46	LH3/32	LH030
MWLN124B	MWLN124B	WN__43	.750	.750	5.00	1.070	1.250							
MWLN164C	MWLN164C	WN__43	1.000	1.000	5.00	1.125	1.250							
MWLN164D	MWLN164D	WN__43	1.000	1.000	6.00	1.070	1.250							
MWLN204D	MWLN204D	WN__43	1.250	1.250	6.00	1.250	1.500							
MWLN244D	MWLN244D	WN__43	1.500	1.500	6.00	1.070	2.000							



WWL Series



Sumitomo Cat. No.		 Applicable Insert	A	B	C	E	F	 Shim	 Cam	 Nut	 Wedge Clamp	 Clamp Screw	 Ring	 Wrench
Right Hand	Left Hand													
WWLNR124B	WWLNL124B	WNMG43-	.750	.750	4.500	1.070	1.000	SWW-433	MP-416	CPM-43S	MWW-40	BHA-0625	ER05	LH030
WWLNR164D	WWLNL164D	WNMG43-	1.000	1.000	6.000	1.070	1.250	SWW-433	MP-420	CPM-43N	MWW-40	BHA-0625	ER05	LH040
WWLNR165D	WWLNL165D	WNMG54-	1.000	1.000	6.000	1.593	1.500	SWW-544	MP-531	CPM-54N	MWW-50	BHA-0834	ER07	LH040
WWLNR204D	WWLNL204D	WNMG43-	1.250	1.250	6.000	1.070	1.500	SWW-433	MP-420	CPM-43N	MWW-40	BHA-0625	ER05	LH040
WWLNR205D	WWLNL205D	WNMG54-	1.250	1.250	6.000	1.593	1.500	SWW-544	MP-534	CPM-54N	MWW-50	BHA-0834	ER07	LH060

Mini TOOLHOLDERS

Pages 217 - 238



Toolholders

TOOLHOLDERS	PAGES
Mini Toolholders.....	218-227
Back Turning Toolholder.....	228
Round Shank Toolholders.....	230-232
SPB Toolholders.....	233
CKB Toolholders.....	234
Twin Head Toolholders.....	236-237
KBM Inserts.....	238



SCAC Series

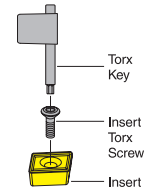
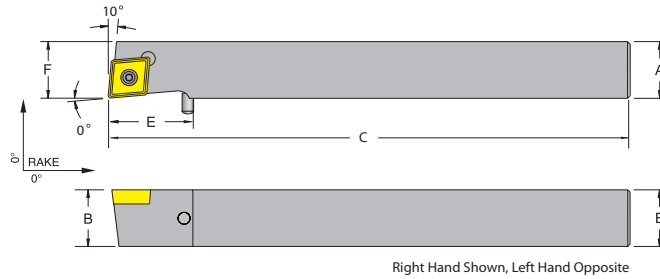
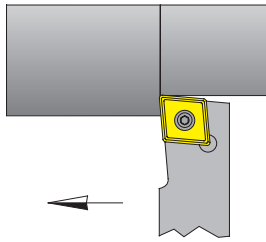

Right Hand Shown, Left Hand Opposite

Catalog Number		Applicable Insert	A	B	C	E (Tool Stop)	F	Insert Torx Screw	Wrench
Right Hand	Left Hand								
SCACR062B	SCACL062B	CC_21.51	0.375	0.375	4.500	1.000	0.375	TS25.45-6M2	TRX08
SCACR062D	SCACL062D		0.375	0.375	6.000	1.000	0.375		
SCACR083B	SCACL083B	CC_32.52	0.500	0.500	4.500	1.000	0.500	TS4.7-10M1	TRX15
SCACR083D	SCACL083D		0.500	0.500	6.000	1.000	0.500		
SCACR103B	SCACL103B		0.625	0.625	4.500	1.000	0.625		
SCACR103D	SCACL103D		0.625	0.625	6.000	1.000	0.625		

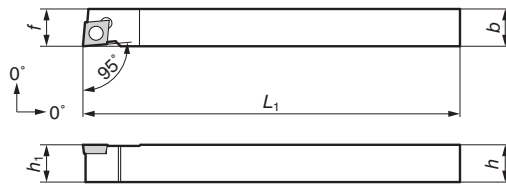
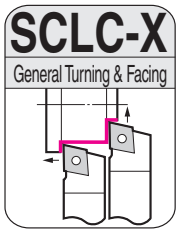

Holder

Above figures show right hand tools.

Parts



Catalog Number	Stock		Applicable Insert	Dimensions (mm)						Screw	Wrench
	R	L		h	b	L1	f	h1			
SCLCR/L1010-H06X	★	★	CC_T21.5	10	10	100	10	10		BFTX02506N	TRX08
SCLCR/L1215-K09X	★	★	CC_T32.5	12	15	125	15	12		BFTX0409N	TRX15
SCLCR/L1215-F09X	★	★	CC_T32.5	12	15	85	15	12			

85mm Shank

★ = Worldwide Warehouse item

SCNC Series

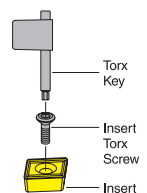
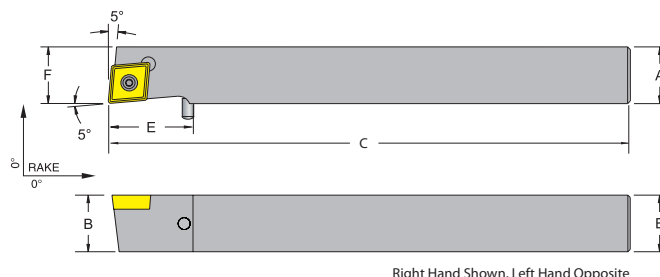
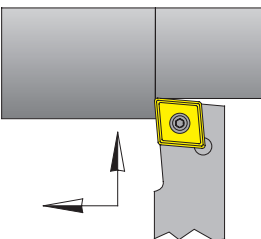

Right Hand Shown, Left Hand Opposite

Catalog Number		Applicable Insert	A	B	C	E (Tool Stop)	F	Insert Torx Screw	Wrench
Right Hand	Left Hand								
SCNCR062B	SCNCL062B	CC_21.51	0.375	0.375	4.500	1.000	0.375	TS25.456M2	TRX08
SCNCR062D	SCNCL062D		0.375	0.375	6.000	1.000	0.375		
SCNCR082B	SCNCL082B	CC_32.52	0.500	0.500	4.500	1.000	0.500	TS4.710M1	TRX15
SCNCR083B	SCNCL083B		0.500	0.500	4.500	1.000	0.500		
SCNCR083D	SCNCL083D		0.500	0.500	6.000	1.000	0.500		
SCNCR103B	SCNCL103B		0.625	0.625	4.500	1.000	0.625		
SCNCR103D	SCNCL103D	0.625	0.625	4.500	1.000	0.625			



Zero Offset Toolholders, Screw Lock

SDAC Series

Right Hand Shown, Left Hand Opposite

Catalog Number		Applicable Insert	A	B	C	E (Tool Stop)	F	Insert Torx Screw	Wrench
Right Hand	Left Hand								
SDACR062B	SDACL062B	DC_21.51	0.375	0.375	4.500	1.000	0.375	TS25.456M2	TRX08
SDACR062D	SDACL062D		0.375	0.375	6.000	1.000	0.375		
SDACR082B	SDACL082B		0.500	0.500	4.500	1.000	0.500		
SDACR082D	SDACL082D		0.500	0.500	6.000	1.000	0.500		
SDACR083B	SDACL083B	DC_32.52	0.500	0.500	4.500	1.000	0.500	TS4.710M1	TRX15
SDACR083D	SDACL083D		0.500	0.500	6.000	.875	0.500		
SDACR103B	SDACL103B		0.625	0.625	4.500	1.000	0.500		
SDACR103D	SDACL103D		0.625	0.625	6.000	1.000	0.625		
SDACR123B	SDACL123B	DC_32.52	0.750	0.750	4.500	1.000	0.750		
SDACR1010-H07X*	SDACL1010-H07X*	DC_21.51	10	10	100	10	10	BFTX02506N	TRX08
SDACR1215-K11X*	SDACL1215-K11X*	DC_32.52	12	15	125	15	12	BFTX0409N	TRX15
SDACR1215-F11X*	SDACL1215-F11X*	DC_32.52	12	15	85	15	12		

* = Worldwide Warehouse Stock

SDJC-X

General Turning & Copying

Above figures show right hand tools.

Catalog Number	Stock		Applicable Insert	Dimensions (mm)					Screw	Wrench
	R	L		h	b	L ₁	f	h ₁		
SDJC R/L1010-H07X	★	★	DC_T21.5	10	10	100	10	10	BFTX02506N	TRX08
SDJC R/L1215-K11X	★	★	DC_T32.5	12	15	125	15	12	BFTX0409N	TRX15
SDJC R/L1215-F11X	★	★	DC_T32.5	12	15	85	15	12		

85mm Shank

SDNC Series

Right Hand Shown, Left Hand Opposite

Catalog Number		Applicable Insert	A	B	C	E (Tool Stop)	F	Insert Torx Screw	Wrench
Right Hand	Left Hand								
SDNCR062B	SDNCL062B	DC_21.51	0.375	0.375	4.500	1.000	0.375	TS25.456M2	TRX08
SDNCR082B	SDNCL082B		0.500	0.500	4.500	1.000	0.500		
SDNCR103B	SDNCL103B	DC_32.52	0.625	0.625	4.500	1.000	0.625	TS4.710M1	TRX15



SDPC Series

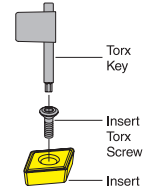
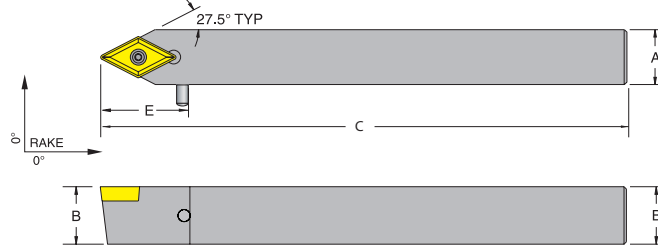
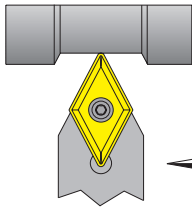

Neutral Hand Shown

Catalog Number	Applicable Insert	A	B	C	E (Tool Stop)	Insert Torx Screw	Wrench
SDPCN062B	DC__21.51	0.375	0.375	4.500	1.000	TS25.456M2	TRX08
SDPCN062D		0.375	0.375	6.000	1.000		
SDPCN082B		0.500	0.500	4.500	1.000		
SDPCN083B	DC__32.52	0.500	0.500	4.500	1.000	TS4.710M1	TRX15
SDPCN083D		0.500	0.500	6.000	1.000		
SDPCN103B		0.625	0.625	4.500	1.000		
SDPCN103D		0.625	0.625	6.000	1.000		

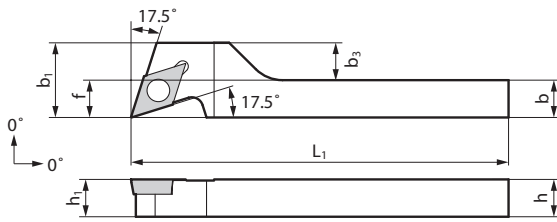
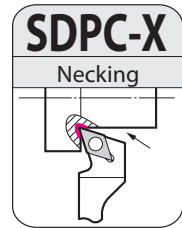

Holder

Above figures show right hand tools.

Parts



Catalog Number	Stock		Applicable Insert	Dimensions (mm)							Screw	Wrench
	R	L		h	b	L1	f	h1	b1	b3		
SDPCR/L1010-H11X	★	★	DC_T32.5	10	10	100	10	10	20	10	BFTX0409N	TRX15

★ = Worldwide Warehouse item

SSDC 45°

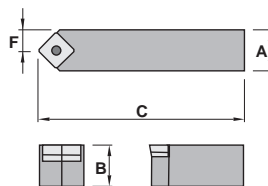
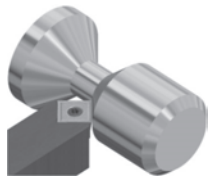

Catalog Number	Applicable Insert	A	B	C	F	Shim	Screw	Shim Screw	Wrench
SSDCN083	SC__32.5	.500	.500	3.5	.263	-	BFTX0407N	-	TRX15
SSDCN124B	SC__43	.750	.750	4.5	.388	SH-3514	ST-1540	TRX15040	BFTX0405



STAC R/L Series

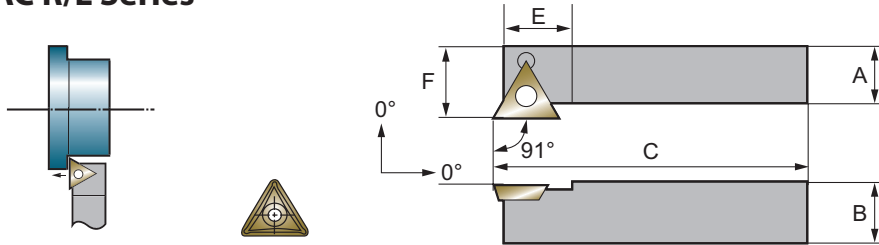

Catalog Number		7° Positive Applicable Insert	Stock	A	B	C	E	F	Insert Screw	Wrench
Right Hand	Left Hand									
STACR062B	STACL062B	TCMT21.51	•	.375	.375	4.500	0.625	0.375	ST-21.5	TRX08
STACR082B	STACL082B	TCMT21.51	•	.500	.500	4.500				
STACR103B	STACL103B	TCMT32.52	•	.625	.625	4.500	0.750	0.625	ST-32.5	TRX15
STACR062D	STACL062D	TCMT21.51	•	.375	.375	6.000	0.625	0.375	ST-21.5	TRX08
STACR082D	STACL082D	TCMT21.51	•	.500	.500	6.000				
STACR102D	STACL102D	TCMT21.51	•	.625	.625	6.000	.625	.625	BFTX02507	TRX15040
STACR103D	STACL103D	TCMT32.52	•	.625	.625	6.000	0.750	0.625	ST-32.5	TRX15
STACR1010-11*	STACL1010-11*	TCMT21.51	★	10.0	10.0	100.0	16.0	12.0	ST-21.5	TRX08
STACR1212-11*	STACL1212-11*	TCMT21.51	★	12.0	12.0	100.0	16.0	16.0	ST-21.5	
STACR1616-16*	STACL1616-16*	TCMT32.52	★	16.0	16.0	100.0	16.0	20.0	ST-32.5	TRX15

* Not zero offset

• = USA stocked item

★ = Worldwide Warehouse item

SVAB R/L Series

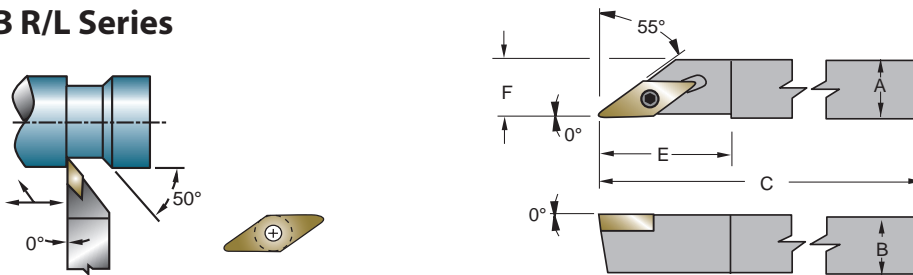

Catalog Number		5° Positive Applicable Insert	Stock	A	B	C	E	F	Insert Screw	Wrench
Right Hand	Left Hand									
SVABR103B	SVABL103B	VBMT332	•	.625	.625	4.500	1.375	0.625	ST-32.5	TRX15
SVABR062D	SVABL062D	VBMT221	•	.375	.375	6.000	0.875	0.375	TS-25.45-8M2	TRX08
SVABR082D	SVABL082D	VBMT221	•	.500	.500	6.000				
SVABR103D	SVABL103D	VBMT332	•	.625	.625	6.000	1.375	0.625	ST-32.5	TRX15
SVABR1010-11	SVABL1010-11	VBMT221		10.0	10.0	150.0	22.0	10.0	ST-21.5	TRX08
SVABR1212-11	SVABL1212-11	VBMT221		12.0	12.0	150.0				
SVABR1616-16	SVABL1616-16	VBMT332		16.0	16.0	150.0	35.0	16.0	ST-32.5	TRX15

• = USA stocked item



Mini TOOLHOLDERS

Series: SVJB • SVJC • SVJC-X

Zero Offset Toolholders, Screw Lock

SVJB 93°

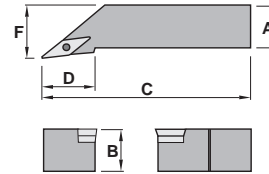

Catalog Number		Applicable Insert	A	B	C	D	F	Shim	Screw	Shim Screw	Wrench
Right	Left										
SVJBR123B	SVJBL123B	VB__33	.750	.750	4.5	.940	.375	SH-3718	BFTX03515	ST-1750	TRX15
SVJBR163D	SVJBL163D	VB__33	1.000	1.000	6.0	1.614	1.500				

SVJC 93°

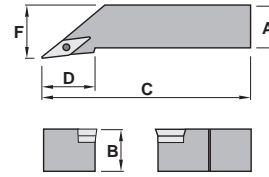

Catalog Number		Applicable Insert	A	B	C	D	F	Shim	Screw	Shim Screw	Wrench
Right	Left										
SVJCR062D	SVJCL062D	VC__22	.375	.375	6.0	.940	.375	-	BFTX02507	-	TRX15040
SVJCR082D	SVJCL082D	VC__22	.500	.500	6.0	.940	.500				
SVJCR083D	SVJCL083D	VC__33	.500	.500	6.0	1.100	.500				
SVJCR103D	SVJCL103D	VC__33	.625	.625	6.0	1.440	.625				
SVJCR123B	SVJCL123B	VC__33	.750	.750	4.5	1.614	1.000	SH-3718	BFTX03515	ST-1750	TRX15
SVJCR163D	SVJCL163D	VC__33	1.000	1.000	6.0	1.614	1.250				
SVJCR203D	SVJCL203D	VC__33	1.250	1.250	6.0	1.614	1.500				

SVJC-X

General Turning & Copying

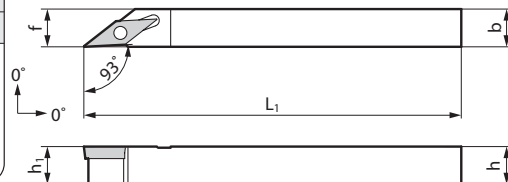
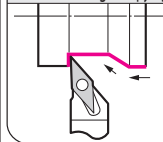

Parts

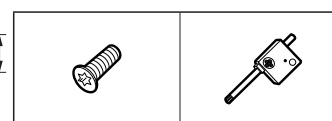

Holder

Above figures show right hand tools.

Catalog Number	Stock		Applicable Insert	Dimensions (mm)					Screw	Wrench
	R	L		h	b	L ₁	f	h ₁		
SVJCR/L1010-H11X	★	★	VC_T22	10	10	100	10	10	BFTX02506N	TRX08
SVJCR/L1212-K11X	★	★	VC_T22	12	12	125	12	12		
SVJCR/L1212-F11X	★	★	VC_T22	12	12	85	12	12		

★ = Worldwide Warehouse item



SVNB Series

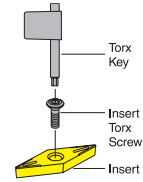
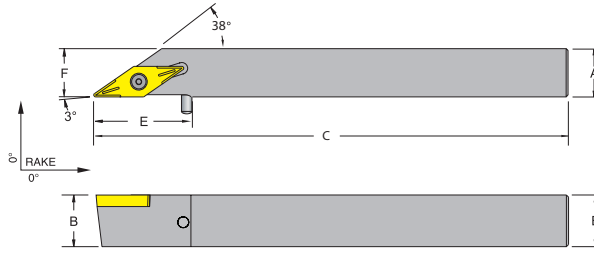
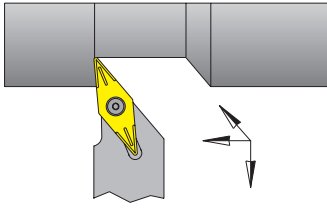

Catalog Number		Applicable Insert	A	B	C	E (Tool Stop)	F	Insert Torx Screw	Wrench
Right Hand	Left Hand								
SVNBR062B	SVNBL062B	VB_22	0.375	0.375	4.500	1.000	0.375	TS25.456M2	TRX08
SVNBR062D	SVNBL062D		0.375	0.375	6.000	1.000	0.375		
SVNBR082B	SVNBL082B		0.500	0.500	4.500	1.000	0.500		
SVNBR082D	SVNBL082D		0.500	0.500	6.000	1.000	0.500		
SVNBR103B	SVNBL103B	VB_33	0.625	0.625	4.500	1.000	0.625	TS4.710M1	TRX15
SVNBR103D	SVNBL103D		0.625	0.625	6.000	1.000	0.625		

SVVC 72° 30'

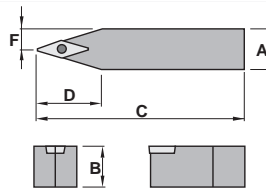
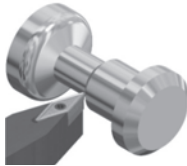

Catalog Number	Applicable Insert	A	B	C	D	F	Shim	Screw	Shim Screw	Wrench
SVVCN123B	VC_33	.750	.750	4.5	1.212	.398	SH-3718	BFTX03515	ST-1750	TRX15
SVVCN163D	VC_33	1.000	1.000	6.0	1.610	.523				



External Turning

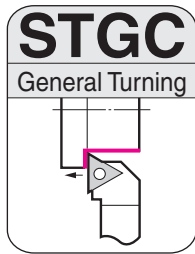

■ Holder

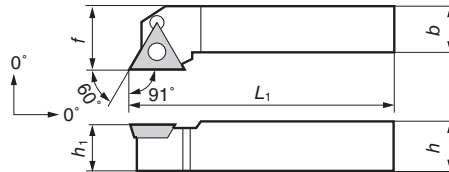

Above figures show right hand tools.

■ Parts

Screw	Wrench
Recommended Tightening Torque (N•m)	

Cat. No.	Stock		Applicable Insert	Dimensions (mm)					Screw	Recommended Tightening Torque (N•m)	Wrench
	R	L		h	b	L ₁	f	h ₁			
STGC R/L0808-09	★		TC□□1.81.5□	8	8	100	10	8	BFTX02205N	0.5	TRX06
STGC R/L1010-09	★	★		10	10	100	12	10			
STGC R/L1212-11	★	★	TC□□21.5□	12	12	100	16	12	BFTX02506N	1.5	TRX08
STGC R/L1616-11	★	★		16	16	100	20	16			
STGC R/L2020-11	★	★		20	20	125	25	20			

★ = Worldwide Warehouse item

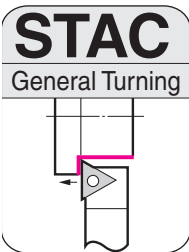

■ Holder

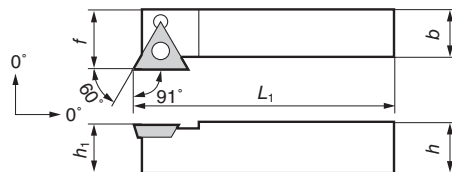

Above figures show right hand tools.

■ Parts

Screw	Wrench
Recommended Tightening Torque (N•m)	

Cat. No.	Stock		Applicable Insert	Dimensions (mm)					Screw	Recommended Tightening Torque (N•m)	Wrench
	R	L		h	b	L ₁	f	h ₁			
STAC R/L0808-09		★	TC□□1.81.5□	8	8	100	8.5	8	BFTX02205N	0.5	TRX06
STAC R/L1010-09	★			10	10	100	10.5	10			
STAC R/L1212-11	★	★	TC□□21.5□	12	12	100	12.5	12	BFTX02506N	1.5	TRX08
STAC R/L1616-11	★	★		16	16	100	16.5	16			
STAC R/L2020-11	★	★		20	20	125	20.5	20			

★ = Worldwide Warehouse item



General Turning and Copying

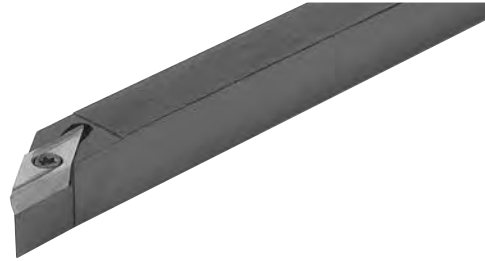

SVLC
General Turning & Copying

Parts

For Torx Holes

Holder Above figures show right hand tools.

Cat. No.	Stock		Applicable Insert	Dimensions (mm)					Screw	Recommended Tightening Torque (N•m)	Wrench
	R	L		h	b	L ₁	f	h ₁			
SVLC R/L1010-H11	★	★	VC□□22□	10	10	100	10.5	10	BFTX02508NV	1.5	TRX08
SVLC R/L1212-H11	★	★		12	12	100	12.5	12			
SVLC R/L1616-H11	★	★		16	16	100	16.5	16			
SVLC R/L2020-K11*	★	★		20	20	125	20.5	20			

★ = Worldwide Warehouse item

* Previous Cat. No SVLCR/L2020-H11

SVPC
Necking

Parts

For Torx Holes

Holder Above figures show right hand tools.

Cat. No.	Stock		Applicable Insert	Dimensions (mm)					Screw	Recommended Tightening Torque (N•m)	Wrench
	R	L		h	b	L ₁	f	h ₁			
SVPC R/L1010-H11	★	★	VC□□22□	10	10	100	14.5	10	BFTX02508NV	1.5	TRX08
SVPC R/L1212-H11	★	★		12	12	100	16.5	12			
SVPC R/L1616-H11	★	★		16	16	100	20.5	16			
SVPC R/L2020-K11*	★	★		20	20	125	24.5	20			

★ = Worldwide Warehouse item

* Previous Cat. No SVLCR/L2020-H11



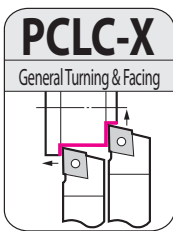

PCLC-X
General Turning & Facing

PCLC R/L1212-K09X

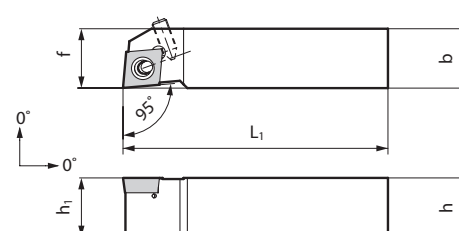
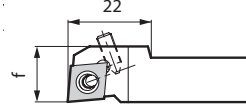
Side lever locking holders

■ Parts

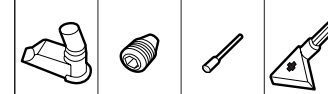

■ Holder

Above figures show right hand tools.

Catalog Number	Stock		Applicable Insert	Dimensions (mm)					Lever Pin	Set Screw	Pin	Wrench
	R	L		h	b	L ₁	f	h ₁				
PCLC R/L1010-K06X	★		CC_T21.5	10	10	125	10	10	LCL06	BTT0407	LP07	TH020
PCLC R/L1212-K09X	★		CC_T32.5	12	12	125	15	12	LCL09	BTT0411	LP06	
PCLC R/L1616-K09X	★		CC_T32.5	16	16	125	16	16				

★ = Worldwide Warehouse item

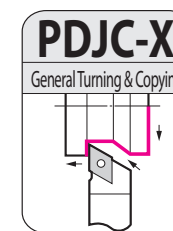

PDJC-X
General Turning & Copying

PDJC R/L1212-K11X

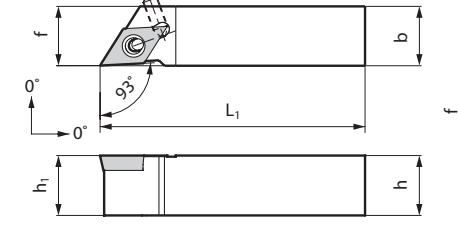
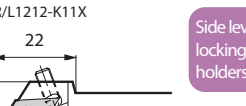
Side lever locking holders

■ Parts

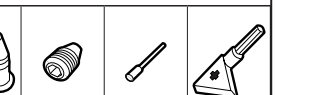

■ Holder

Above figures show right hand tools.

Catalog Number	Stock		Applicable Insert	Dimensions (mm)					Lever Pin	Set Screw	Pin	Wrench
	R	L		h	b	L ₁	f	h ₁				
PDJC R/L1010-K07X	★		DC_T21.5	10	10	125	10	10	LCL06	BTT0407	LP04	TH020
PDJC R/L1212-K11X	★		DC_T32.5	12	12	125	15	12	LCL09	BTT0411	LP07	
PDJC R/L1616-K11X	★		DC_T32.5	16	16	125	16	16				

★ = Worldwide Warehouse item

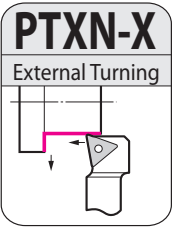

PTXN-X
External Turning

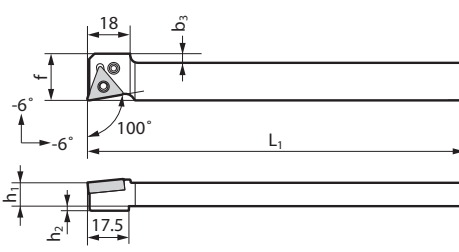







■ Parts



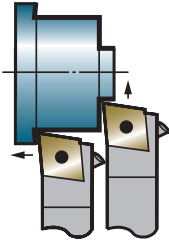
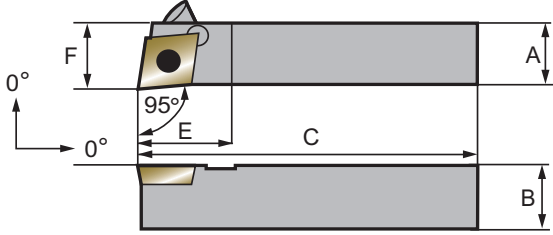





■ Holder

Catalog Number	Stock	Applicable Insert	Dimensions (mm)							Lever Pin	Screw	Wrench
			h	b	L ₁	f	h ₁	h ₂	b ₃			
PTXN R1016-X16X	★	TN□□33	10	16	120	20	10	2	4	LCL33NT	LCS33NT	LH020NT
PTXN R1216-X16X	★	TN□□33	12	16	120	20	12	0	4			
PTXN R1616-X16X	★	TN□□33	16	16	120	20	16	0	4			
PTXN R2020-X16X	★	TN□□33	20	20	120	20	20	0	0			

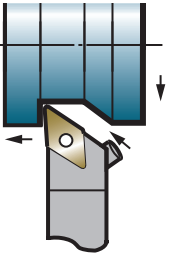
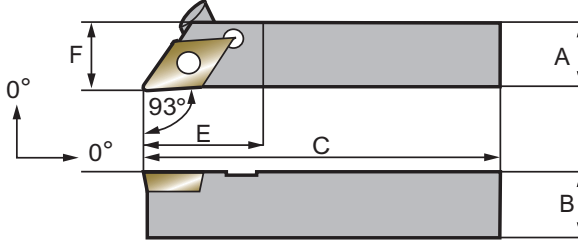
★ = Worldwide Warehouse item



PCLC R/LSeries			Side lever locking holders									
												
Sumitomo Cat. No.			Dimensions (inch/mm)									
Right Hand	Left Hand	7° Positive Applicable Insert	Stock	A	B	C	E	F	Lever Pin	Clamp Bolt	Pin	Wrench
PCLCR062D	PCLCL062D	CCMT21.51	●	.375	.375	6.000	.472	.395	LCL06	BTT0407	LP07	TH020
PCLCR083D	PCLCL083D	CCMT32.52	●	.500	.500	6.000	.591	.520	LCL09	BTT0407	LP06	TH020
PCLCR103D	PCLCL103D	CCMT32.52	●	.625	.625	6.000	.630	.645	LCL09	BTT0411	LP06	TH020
PCLCR1010-K06	PCLCL1010-K06	CCMT21.51	★	10.0	10.0	125.0	12.0	10.5	LCL06	BTT0407	LP07	TH020
PCLCR1212-K09	PCLCL1212-K09	CCMT32.52	★	12.0	12.0	150.0	16.0	12.5	LCL09	BTT0407	LP06	TH020
PCLCR1616-M09	PCLCL1616-M09	CCMT32.52	★	16.0	16.0	150.0	16.0	16.5	LCL09	BTT0411	LP06	TH020

● = USA stocked item ★ = Worldwide Warehouse item

PDJC R/LSeries			Side lever locking holders									
												
Sumitomo Cat. No.			Dimensions (Inch/mm)									
Right Hand	Left Hand	7° Positive Applicable Insert	Stock	A	B	C	E	F	Lever Pin	Clamp Bolt	Pin	Wrench
PDJCR062D	PDJCL062D	DCMT21.51	●	.375	.375	6.000	.472	.395	LCL06	BTT0407	LP04	TH020
PDJCR083D	PDJCL083D	DCMT32.52	●	.500	.500	6.000	.787	.520	LCL09	BTT0407	LP07	TH020
PDJCR103D	PDJCL103D	DCMT32.52	●	.625	.625	6.000	.787	.645	LCL09	BTT0411	LP07	TH020
PDJCR1010-K07	PDJCL1010-K07	DCMT21.51	★	10.0	10.0	125.0	15.0	10.5	LCL06	BTT0407	LP04	TH020
PDJCR1212-M11	PDJCL1212-M11	DCMT32.52	★	12.0	12.0	150.0	20.0	12.5	LCL09	BTT0407	LP07	TH020
PDJCR1616-M11	PDJCL1616-M11	DCMT32.52	★	16.0	16.0	150.0	20.0	16.5	LCL09	BTT0411	LP07	TH020

● = USA stocked item ★ = Worldwide Warehouse item

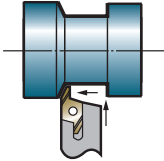
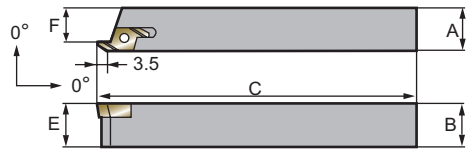

SBT R Series			Back Turning Holders								
			See page for inserts								
Sumitomo Cat. No.			Dimensions (Inch/mm)								
Right Hand	Left Hand	Applicable Insert	Stock	A	B	C	E	F	Insert Screw	Torx Wrench	
		BTR35	●	.375	.375	6.000	.375	.295	BFTX0307N	TRX10	
		BTR35	●	.500	.500	6.000	.500	.394	BFTX0307N	TRX10	
		BTR35	●	.625	.625	6.000	.625	.492	BFTX0307N	TRX10	
		BTR35	★	10.0	10.0	120.0	10.0	7.5	BFTX0307N	TRX10	
		BTR35	★	12.0	12.0	120.0	12.0	9.5	BFTX0307N	TRX10	
		BTR35	★	16.0	16.0	120.0	16.0	13.5	BFTX0307N	TRX10	
		BTR35	★	20.0	20.0	120.0	20.0	17.5	BFTX0307N	TRX10	

● = USA stocked item ★ = Worldwide Warehouse item

Swiss Tooling Inserts
for precision turning applications:

- Cut-off
- Back Turn
- Boring/Roughing
- Boring/Finishing

- P** Steel
- M** Stainless Steel
- K** Cast Iron
- N** Non-ferrous
- S** Exotic Materials
- H** Hardened Steel

- USA Stocked Item
- ★ Worldwide Warehouse Item
- ▲ USA Limited Availability Item

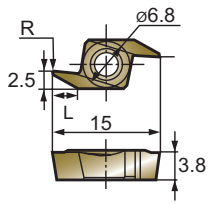
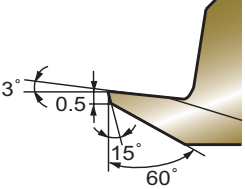
BTR for SBT Type Holder									Coated	Cermet	Uncoated	
Sumitomo Catalog #	ISO Catalog #	I.C.	T	L	r	AC530U	TI 500A	TI 200A				
BTR3505	BTR3505	6.8	3.8	3.5	0.05	●						
BTR3515	BTR3515			3.5	0.15	●						
BTR5505	BTR5505			5.5	0.05	★		★				
BTR5515	BTR5515			5.5	0.15	★		★				
BTR8005	BTR8005			8.0	0.05	★						
BTR8015	BTR8015			8.0	0.15	★						





SFT

External Turning

Parts

Screw

Wrench
(For Torx Holes)

Cat. No.	Stock	Applicable Insert	Dimensions (mm)					Screw	Wrench
			<i>h</i>	<i>b</i>	<i>L1</i>	<i>f</i>	<i>h1</i>		
SFT R1010	★	TFR33○○	10	10	120	10	10	BFTX0410NSW	RT08
SFT R1212	★		12	12	120	12	12		
SFT R1616	★		16	16	120	16	16		
SFT R2020	★		20	20	120	20	20		

★ = Worldwide Warehouse item

Insert

Cat. No.	Stock	Dimensions (mm)			Holder
		$\varnothing d$	<i>w</i>	r_E	
TF R3300	★	9.525	4.76	-	SFT R○○○○
TF R3305	★	9.525	4.76	0.05	
TF R3315	★	9.525	4.76	0.15	
TF R3320	★	9.525	4.76	0.20	

*1 Max. depth-of-cut is 4.0 mm.
*2 Indicates angle when setting the holder.

★ = Worldwide Warehouse item



Mini TOOLHOLDERS

Series: RS-SCLL Type

Round Shank Toolholders



■ Characteristics

- Shank diameters from $\varnothing 14$ to $\varnothing 25$ are stocked. Holders can be fitted on machines of different makes.
- Bars can be mounted from the rear of the sleeve to increase the tooling range.

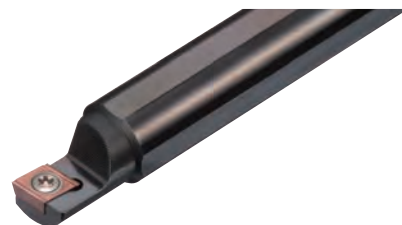

General Turning

RS-SCLL
General Turning & Copying

■ Parts

	RT08 LT25NT
	(For Torx Holes)

Above figures show left hand tools.

Cat. No.	Stock	Applicable Insert	Dimensions (mm)					Screw	Wrench
			$\varnothing D_s$	h	L_1	f	L_2		
RS15H-SCLL06	★	CC □ □ 21.5	15.875	15	100	6.0	20	BFTX02507NT	RT08
RS19X-SCLL06	★		19.05	18	120	6.0	20		
RS20X-SCLL06X	★		20	19	95	6.0	20		
RS20X-SCLL06	★		20	19	120	6.0	20		
RS22X-SCLL06	★		22	21	120	6.0	20		
RS25X-SCLL06	★		25	24	120	6.0	20		
RS25M-SCLL06	★		25.4	24	150	6.0	20		
RS15H-SCLL09	★	CC □ □ 32.5	15.875	15	100	6.0	20	BFTX0408NT	LT25NT
RS19X-SCLL09	★		19.05	18	120	6.0	20		
RS20X-SCLL09S	★		20	19	95	6.0	20		
RS20X-SCLL09	★		20	19	120	6.0	20		
RS22X-SCLL09	★		22	21	120	6.0	20		
RS25X-SCLL09	★		25	24	120	6.0	20		
RS25M-SCLL09	★		25.4	24	150	6.0	20		

★ = Worldwide Warehouse item * Right handed or neutral handed inserts are applicable.





General Turning

RS-SDUL
General Turning & Copying

Parts

RT08 LT25NT
(For Torx Holes)

Above figures show left hand tools.

Cat. No.	Stock	Applicable Insert	Dimensions (mm)					Screw	Wrench
			ϕD_s	h	L_1	f	L_2		
RS14F-SDUL07	★	DC□□21.5□	14	13	80	6.0	20	BFTX02507NT	RT08
RS15H-SDUL07	★		15.875	15	100	6.0	20		
RS16F-SDUL07	★		16	15	80	6.0	20		
RS16X-SDUL07	★		16	15	120	6.0	20		
RS19X-SDUL07	★		19.05	18	120	6.0	20		
RS20X-SDUL07S	★		20	19	95	6.0	20		
RS20X-SDUL07	★		20	19	120	6.0	20		
RS22X-SDUL07	★		22	21	120	6.0	20		
RS19X-SDUL11	★	DC□□32.5□	19.05	18	120	10.0	20	BFTX0410NT	LT25NT
RS20X-SDUL11S	★		20	19	95	10.0	20		
RS20X-SDUL11	★		20	19	120	10.0	20		
RS22X-SDUL11	★		22	21	120	10.0	20		
RS25X-SDUL11	★		25	24	120	10.0	20		
RS25M-SDUL11	★		25.4	24	150	10.0	20		

★ = Worldwide Warehouse item * Right handed or neutral handed inserts are applicable.

RS-SDXL
General Turning & Copying

Parts

(For Torx Holes)

Above figures show left hand tools.

Cat. No.	Stock	Applicable Insert	Dimensions (mm)					Screw	Wrench
			ϕD_s	h	L_1	f	L_2		
RS19X-SDXL11	★	DC□□32.5□	19.05	18	120	10.0	20	BFTX0410NT	LT25NT
RS20X-SDXL11S	★		20	19	95	10.0	20		
RS20X-SDXL11	★		20	19	120	10.0	20		
RS25X-SDXL11	★		25	24	120	10.0	20		

★ = Worldwide Warehouse item * Right handed or neutral handed inserts are applicable.



Mini TOOLHOLDERS

Series: RS-SVXL • RS-SVVP • RS-PTXN Type

Round Shank Toolholders

General Turning

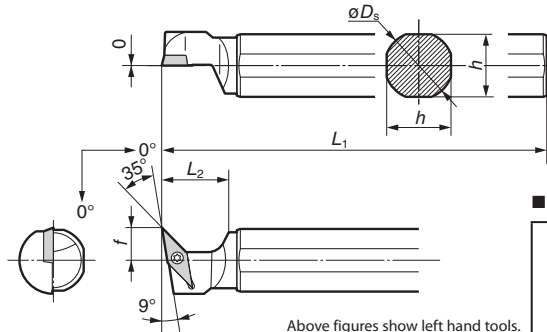
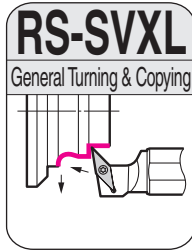

Holder

Parts



(For Torx Holes)

Cat. No.	Stock	Applicable Insert	Dimensions (mm)					Screw	Wrench
			ϕD_s	h	L_1	f	L_2		
RS15H-SVXL11	★	VC□□22□	15.875	15	100	10.0	20	BFTX02507NT	RT08
RS19X-SVXL11	★		19.05	18	120	10.0	20		
RS20X-SVXL11S	★		20	19	95	10.0	20		
RS20X-SVXL11	★		20	19	120	10.0	20		
RS22X-SVXL11	★		22	21	120	10.0	20		
RS25X-SVXL11	★		25.4	24	150	10.0	20		

★ = Worldwide Warehouse item * Right handed or neutral handed inserts are applicable.

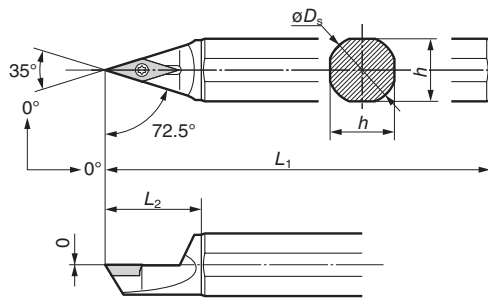
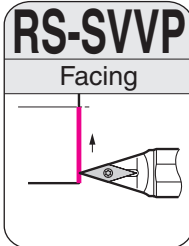

Holder

Parts



(For Torx Holes)

Cat. No.	Stock	Applicable Insert	Dimensions (mm)					Screw	Wrench
			ϕD_s	h	L_1	f	L_2		
RS19X-SVVPN11	★	VP□□22□	19.05	18	120	9.0	27	BFTX02507NT	RT08
RS22X-SVVPN11	★		22	21	120	10.5	27		

★ = Worldwide Warehouse item

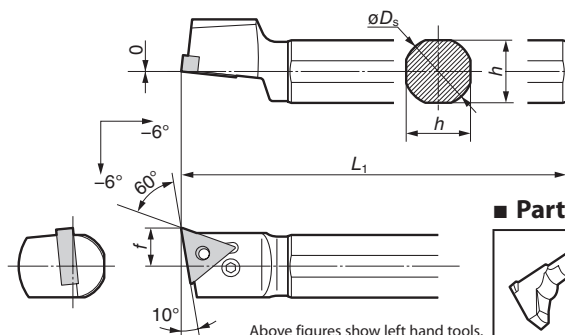
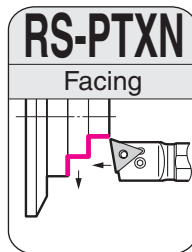

Holder

Parts



(For Hexagonal Holes)

Cat. No.	Stock	Applicable Insert	Dimensions (mm)				Lever Pin	Screw	Wrench
			ϕD_s	h	L_1	f			
RS19X-PTXNL16	★	TN□□33	19.05	18	120	11.0	LCL33NT	LCS33NT	LH020NT
RS20X-PTXNL16	★		20	19	120	11.0			
RS25M-PTXNL16	★		25.4	24	150	13.0			

★ = Worldwide Warehouse item



SPB Type Holder

Mini TOOLHOLDERS

Series: SPB Type

Swiss Toolholders

SPB R/L Series			Dimensions (Inch/mm)								
Sumitomo Cat. No.		Applicable Insert	Stock	A	B	C	E	F	Insert Screw	Torx Wrench	
SPBR063D	SPBL063D	PBV1102	●	.375	.375	6.000	.669	.375	BFTX02505N	LT08-06	
SPBR083D	SPBL083D	PBV1102	●	.500	.500	6.000	.669	.500	BFTX02505N	LT08-06	
SPBR1010-60	SPBL1010-60	PBV1102	★	10.0	10.0	150.0	17.0	10.5	BFTX02505N	LT08-06	
SPBR1212-60	SPBL1212-60	PBV1102	★	12.0	12.0	150.0	17.0	12.5	BFTX02505N	LT08-06	

● = USA stocked item ★ = Worldwide Warehouse item

Swiss Tooling Inserts

for precision turning applications:

- Cut-off
- Boring Roughing
- Back Turn
- Boring Finishing

- P Steel
- M Stainless Steel
- K Cast Iron
- N Non-ferrous
- S Exotic Materials
- H Hardened Steel

- USA Stocked Item
- ★ Worldwide Warehouse Item
- ▲ USA Limited Availability Item

Blank Inserts for SPB Type holder (See above)				Uncoated	
Fig. 1	Fig. 2	Fig. 3			
Sumitomo Catalog #	Dim. E (mm)	Application	Fig.	BL130	
PBVX1102R-NB	17.20	General	1	★	
PBVX1102R-SB	20.14	Sharp Edge	2	★	
PBVX1102R-BB	14.20	Special	3	★	

Grooving Inserts for SPB Type holder (See above)			Uncoated	
Sumitomo Catalog #	Dimensions (mm)		BL130	
	Groove Depth	t		
PBVG1102R-030	0.5	0.3	★	
PBVG1102R-050	1.0	0.5	★	
PBVG1102R-100	2.0	1.0	★	

Turning Inserts for SPB Type holder (See above)				Uncoated	
Fig. 1	Fig. 2				
Sumitomo Catalog #	Cutting Edge Width (mm)	Wiper Edge	Fig.	BL130	
PBVFW1102R	1.0	Yes	1	★	
PBVFN1102R	1.0	No	2	★	

Threading Inserts for SPB Type holder (See above)			Uncoated		
Fig. 1	Fig. 2				
Sumitomo Catalog #	Pitch (mm)	Fig.	BL130		
PBVTf1102R	0.2 ~ 0.5	1	★		
PBVTB1102R	0.2 ~ 0.5	2	★		

Back Turning Inserts for SPB Type holder (See above)				Uncoated	
Fig. 1	Fig. 2				
Sumitomo Catalog #	Cutting Edge Width (mm)	Wiper Edge	Fig.	BL130	
PBVBN1102R	1.0	Yes	1	★	
PBVBN1102R	1.0	No	2	★	

Cut-off Inserts for SPB Type holder (See above)				Uncoated	
Fig. 1	Fig. 2				
Sumitomo Catalog #	Cutting Edge Width (mm)	Maximum Cut-off diameter	Fig.	BL130	
PBVC1102L-50	1.0	5.0	1	★	
PBVC1102R-50	1.0	5.0	2	★	



CKBR Series

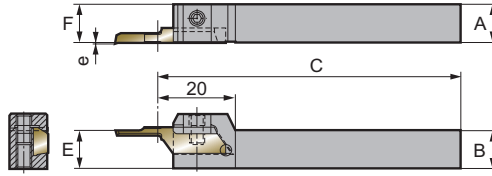
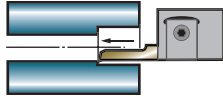

Sumitomo Cat. No.		Applicable Insert	Dimensions (Inch/mm)						Clamp	Clamp Screw	Wrench
Right Hand	Left Hand		Stock	A	B	C	E	F			
		KBMXR	•	.375	.375	6.000	.375	.375	CKBW16	WB4-8	LH020
		KBMXR	•	.500	.500	6.000	.500	.500	CKBW16	WB4-8	LH020
		KBMXR	•	.625	.625	6.000	.625	.625	CKBW16	WB4-8	LH020
		KBMXR	★	10.0	10.0	150.0	10.0	10.0	CKBW16	WB4-8	LH020
		KBMXR	★	12.0	12.0	150.0	12.0	12.0	CKBW16	WB4-8	LH020
		KBMXR	★	16.0	16.0	150.0	16.0	16.0	CKBW16	WB4-8	LH020

• = USA stocked item

★ = Worldwide Warehouse item

KB Turning Insert pg. 238

CKBSR Series

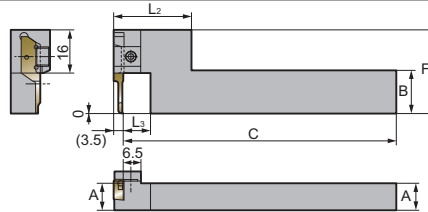
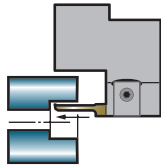

Sumitomo Cat. No.		Applicable Insert	Dimensions (Inch/mm)							Clamp	Clamp Screw	Wrench
Right Hand	Left Hand		Stock	A	B	C	F	L ₂	L ₃			
		KBMXL	•	.625	.625	6.000	1.220	1.125	.393	CKBW16	WB4-8	LH020
		KBMXL	★	10.0	16.0	150.0	31.0	28.5	10.0	CKBW16	WB4-8	LH020
		KBMXL	★	12.0	16.0	150.0	31.0	28.5	10.0	CKBW16	WB4-8	LH020
		KBMXL	★	16.0	16.0	150.0	31.0	28.5	16.0	CKBW16	WB4-8	LH020

• = USA stocked item

★ = Worldwide Warehouse item

KB Turning Insert pg. 238





Square Shank

Holder

Please refer to facing page E15 for e_1, l_1 dimensions.

Spare Parts

Clamp	Double Screw	Wrench
CKBW16	WB4-8	LH020

(For Hexagonal Holes)

Cat. No.	Stock	Dimensions (mm)					Clamp	Double Screw	Wrench
		h	b	L	f	h_1			
CKB R1010-16	★	10	10	100	10	CKBW16	WB4-8	LH020	
CKB R1212-16	★	12	12	125	12				
CKB R1616-16	★	16	16	125	16				
CKB R2020-16	★	20	20	125	20				
CKB R2525-16	★	25	25	150	25				

★ = Worldwide Warehouse item

KB Turning Insert pg. 238

Round Shank (Offset Small)

Holder

Please refer to facing page E15 for e_1, l_1 dimensions.

Spare Parts

Clamp	Double Screw	Wrench
CKBW16	WB4-8	LH020

(For Hexagonal Holes)

Cat. No.	Stock	Dimensions (mm)				Clamp	Double Screw	Wrench
		ϕD_s	h	L	f			
S1905H-CKB RS-16	★	19.05	17	100	2	CKBW16	WB4-8	LH020
S20H-CKB RS-16	★	20	18	100	2			
S22K-CKB RS-16	★	22	19	125	2			
S25K-CKB RS-16	★	25	23	125	2			
S254K-CKB RS-16	★	25.4	23	125	2			

★ = Worldwide Warehouse item

KB Turning Insert pg. 238

Round Shank

Holder

Please refer to facing page E15 for e_1, l_1 dimensions.

Spare Parts

Clamp	Double Screw	Wrench
CKBW16	WB4-8	LH020

(For Hexagonal Holes)

Cat. No.	Stock	Dimensions (mm)					Clamp	Double Screw	Wrench
		ϕD_s	h	L	L_s	f			
S10F-CKB R-16	★	10	9	80	58	5	CKBW16	WB4-8	LH020
S12F-CKB R-16	★	12	11	80	58	6			
S16H-CKB R-16	★	16	15	100	78	8			
S19K-CKB R-16	★	19.05	17	125	103	8			
S20K-CKB R-16	★	20	18	125	103	10			

★ = Worldwide Warehouse item

KB Turning Insert pg. 238



Mini TOOLHOLDERS

Series: CKBE Type

Twin Head Toolholders



Characteristics

- 1 holder that performs 2 operations is equivalent to mounting an additional tool on the machine.
- External turning possible with the aid of a drill sleeve.
- 2 holder configurations, internal+external and internal+internal, are standard stocked items.
- Height difference of the 2 cutting edges is below 40µm which is good for high precision machining.

Advantage of twin-head holder

- Conventional tool

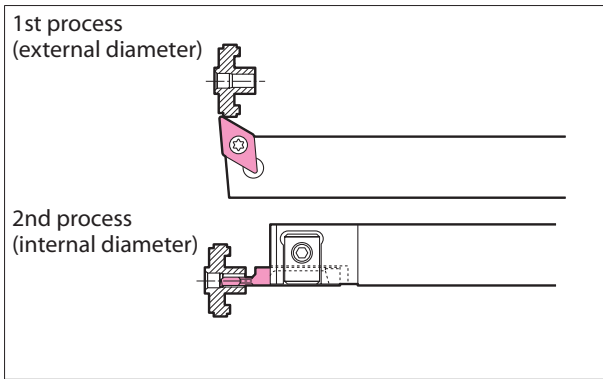

• 2 different operations requiring 2 separate tools.

- Twin head holder

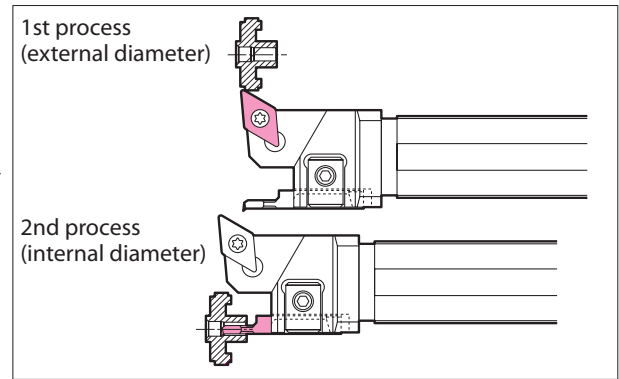

• A single tool performing 2 different operations.

• Cycle time can be reduced.

Boring External Tool Holder

CKBE type

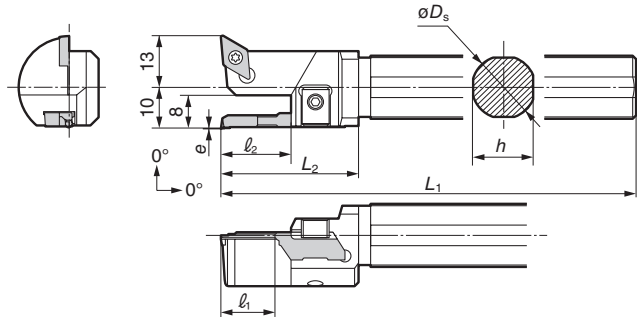
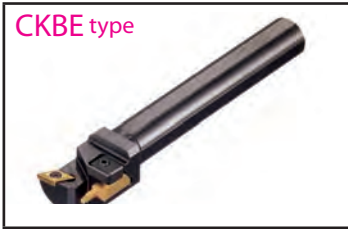

Please refer to page E13 for e.

Holder (ID boring depth 6.0mm type)

Cat. No.	Stock	Dimensions (mm)						*Maximum workpiece diameter	ID Boring Insert	OD Turning Insert
		ϕD_s	h	L_1	L_2	l_1	l_2			
S1588X-CKBE-06	★	15.875	15	130	27	6	10	12.0	KBMX R0006-00 KBMX R0006-00T	DC□□21.5□
S16X-CKBE-06	★	16	15	130	27	6	10	12.0		
S1905X-CKBE-06	★	19.05	17	130	27	6	10	12.0		
S20X-CKBE-06	★	20	18	130	27	6	10	12.0		
S22X-CKBE-06	★	22	20	130	27	6	10	12.0		

★ = Worldwide Warehouse item * When machining internal diameter

Holder (ID boring depth 11.0mm type)

Cat. No.	Stock	Dimensions (mm)						*Maximum workpiece diameter	ID Boring Insert	OD Turning Insert
		ϕD_s	h	L_1	L_2	l_1	l_2			
S1588X-CKBE-11	★	15.875	15	130	32	11	15	12.0	KBMX R0011-00 KBMX R0011-00T	DC□□21.5□
S16X-CKBE-11	★	16	15	130	32	11	15	12.0		
S1905X-CKBE-11	★	19.05	17	130	32	11	15	12.0		
S20X-CKBE-11	★	20	18	130	32	11	15	12.0		
S22X-CKBE-11	★	22	20	130	32	11	15	12.0		

★ = Worldwide Warehouse item * When machining internal diameter



Twin Head Toolholders

Mini TOOLHOLDERS

Series: CKBB

Boring + Face Grooving

CKBB type

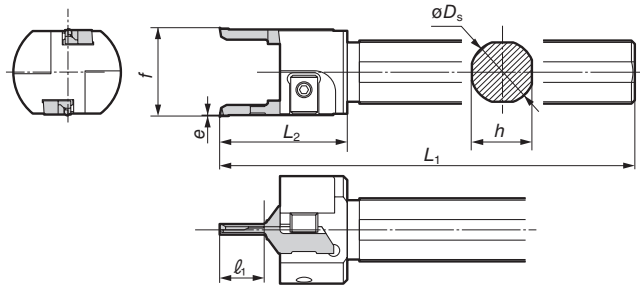

Please refer to facing page E15 for ϵ , ℓ_1 dimensions.

Holder

Cat. No.	Stock	Dimensions (mm)						ID Boring Insert	OD Turning Insert
		ϕD_s	h	L_1	L_2	f	N		
S1588X-CKBB-F	★	15.875	15	130	32	22.0	11	KBMX R○○○○-○○ KBMX R○○○○-OOT	KBMF R○○○○-05
S16X-CKBB-F	★	16	15	130	32	22.0	11		
S1905X-CKBB-F	★	19.05	17	130	32	22.0	11		
S20X-CKBB-F	★	20	18	130	32	22.0	11		
S22X-CKBB-F	★	22	20	130	32	22.0	11		

* Reference for L_1 , f , and ℓ_1 are taken with KBMXR0311-OO(T) mounted.

★ = Worldwide Warehouse item

KB Turning Insert pg. 238

Spare Parts

For use with KBM □ R insert			For use with DC □ □ insert		
Clamp	Double Screw	Wrench	Screw	Recommended Tightening Torque (N·m)	Wrench
CKBW16	WB4-8	LH020	BFTX02506N	1.5	TRX08

Special Holder Configurations

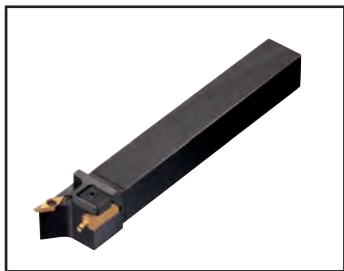

Int. diameter+Ext. diameter
(Square shank holder)



Inner diameter + Center drill



Int. diameter + Int. diameter
(Parallel boring holder)

Holder configurations for different workpieces or various machining requirements, such as guide holes, chamfering and external necking, can be custom-made.



Mini TOOLHOLDERS

Series: KBM Inserts

KBM Inserts

Swiss Tooling Inserts

for precision turning applications:

- Cut-off
- Back Turn
- Boring Rough
- Boring Finishing

- P** Steel
- M** Stainless Steel
- K** Cast Iron
- N** Non-ferrous
- S** Exotic Materials
- H** Hardened Steel

- USA Stocked Item
- ★ Worldwide Warehouse Item
- ▲ USA Limited Availability Item

KBMXR

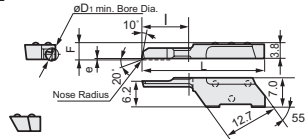

KBMZ

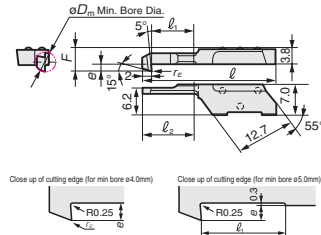

KBMFR

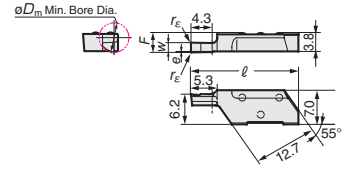

KBMXL

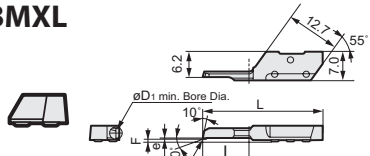

Left hand insert with right hand cut shown

KBMG

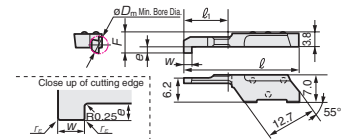

Sumitomo Catalog #	Dimensions (mm)						ACZ310	DA2200
	Min. Bore Dia.	F	e	Nose Radius	L	ℓ		
KBMXR0103-05	1.0	4.00	0.20	0.05	20.5	3	▲	
KBMXR0103-20	1.0	4.00	0.20	0.20	20.5	3	★	
KBMXR01506-05	1.5	4.05	0.25	0.05	23.5	6	★	
KBMXR01506-20	1.5	4.05	0.25	0.20	23.5	6	★	
KBMXR0206-05	2.0	4.05	0.25	0.05	23.5	6	▲	
KBMXR0206-20	2.0	4.05	0.25	0.20	23.5	6	★	
KBMXR0311-05	3.0	4.10	0.30	0.05	28.5	11	★	
KBMXR0311-10	3.0	4.10	0.30	0.10	28.5	11	★	
KBMXR0311-20	3.0	4.10	0.30	0.20	28.5	11	★	
KBMXR0411-05	4.0	4.30	0.50	0.05	28.5	11	▲	
KBMXR0411-10	4.0	4.30	0.50	0.10	28.5	11	★	
KBMXR0411-20	4.0	4.30	0.50	0.20	28.5	11	▲	
KBMXR0420-05	4.0	4.30	0.50	0.05	37.5	20	▲	
KBMXR0420-20	4.0	4.30	0.50	0.20	37.5	20	★	
KBMXR0511-05	5.0	4.50	0.70	0.05	28.5	11	▲	
KBMXR0511-10	5.0	4.50	0.70	0.10	28.5	11	★	
KBMXR0511-20	5.0	4.50	0.70	0.20	28.5	11	▲	
KBMXR0520-05	5.0	4.50	0.70	0.05	37.5	20	★	
KBMXR0520-20	5.0	4.50	0.70	0.20	37.5	20	★	

Sumitomo Catalog #	Dimensions (mm)						ACZ310	ACZ150
	Min. Bore Dia.	F	e	Nose Radius	L	ℓ		
KBMXR0103-05T	1.0	4.00	0.20	0.05	20.5	3	▲	
KBMXR0103-20T	1.0	4.00	0.20	0.20	20.5	3	★	
KBMXR01506-05T	1.5	4.05	0.25	0.05	23.5	6	★	
KBMXR01506-20T	1.5	4.05	0.25	0.20	23.5	6	★	
KBMXR0206-05T	2.0	4.05	0.25	0.05	23.5	6	▲	
KBMXR0206-20T	2.0	4.05	0.25	0.20	23.5	6	★	
KBMXR0311-05T	3.0	4.10	0.30	0.05	28.5	11	★	
KBMXR0311-20T	3.0	4.10	0.30	0.20	28.5	11	★	
KBMXR0411-05T	4.0	4.30	0.50	0.05	28.5	11	▲	
KBMXR0411-20T	4.0	4.30	0.50	0.20	28.5	11	▲	
KBMXR0511-05T	5.0	4.50	0.70	0.05	28.5	11	▲	
KBMXR0511-20T	5.0	4.50	0.70	0.20	28.5	11	▲	

T = Free cutting

Sumitomo Catalog #	Dimensions (mm)						ACZ310
	Min. Bore Dia.	F	e	Nose Radius	L	ℓ	
KBMXL0206-05R	2.0	0.50	0.25	0.05	23.5	6	▲
KBMXL0206-20R	2.0	0.50	0.25	0.20	23.5	6	★
KBMXL0311-05R	3.0	0.50	0.30	0.05	28.5	11	★
KBMXL0311-20R	3.0	0.50	0.30	0.20	28.5	11	★
KBMXL0411-05R	4.0	0.50	0.50	0.05	28.5	11	▲
KBMXL0411-20R	4.0	0.50	0.50	0.20	28.5	11	▲
KBMXL0511-05R	5.0	0.50	0.50	0.05	28.5	11	★
KBMXL0511-20R	5.0	0.50	0.50	0.20	28.5	11	★
KBMXL0520-05R	5.0	0.50	0.50	0.05	37.5	20	★
KBMXL0520-20R	5.0	0.50	0.50	0.20	37.5	20	★

Sumitomo Catalog #	Dimensions (mm)							ACZ150
	Min. Bore Dia.	W	F	e	Corner Radius	L	Maximum groove depth	
KBMFR0615-05	6.0	1.5	4.00	0.20	0.05	21.8	4.0	★
KBMFR0620-05	6.0	2.0	4.00	0.20	0.05	21.8	4.0	★
KBMFR0630-05	6.0	3.0	4.00	0.20	0.05	21.8	4.0	★

Sumitomo Catalog #	Dimensions (mm)							ACZ310
	Min. Bore Dia.	F	e	Nose Radius	L	ℓ ₁	ℓ ₂	
KBMZR0411-05	4.0	5.10	1.10	0.05	28.5	9	11	★
KBMZR0411-20				0.20				★
KBMZR0511-05	5.0	5.10	1.30	0.05	28.5	9	11	★
KBMZR0511-20				0.20				★

Sumitomo Catalog #	Dimensions (mm)							ACZ310
	Min. Bore Dia.	W	F	e	Corner Radius	L	ℓ	
KBMGR0411-05	4.0	1.0	4.90	1.10	0.05	28.5	11	★
KBMGR0411-10		2.0			0.10			★
KBMGR0511-05	5.0	1.0	5.10	1.30	0.05	28.5	11	★
KBMGR0511-10		2.0			0.10			★



BORING BARS

Pages 239-275



Boring Bars

BORING BARS	PAGES
Nomenclature.....	240-241
Insert Holding Method Overview	242
SumiTurn T-REX.....	243
ANSI Standard Combination Boring Bars	244-247
ANSI-ISO "Screw On" Boring Bars	
Steel Shank	248-255
Carbide Shank.....	256-258
X-Bar	259-263
Sumitomo Boring Bars	
Nomenclature	264
Steel Shank	265-268
Carbide Shank.....	269
Solid Carbide Bar with Sleeve	270
CBN Brazed on	
Solid Carbide	271-274
PCD Brazed on	
Solid Carbide	275

A**Boring Bar Type****A**

Solid Steel Bar with Coolant Hole

B

Solid Steel Bar with Anti-Vibration Device

C

Solid Carbide Bar

D

Solid Steel Bar with Anti-Vibration Device and coolant hole

E

Carbide Bar with Fixed Steel Head & Coolant Hole

S

Solid Steel Bar

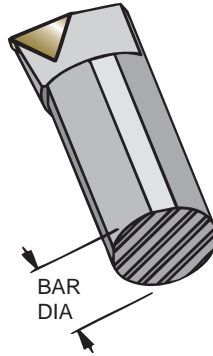
16-**Boring Bar Diameter**

This indicates D dimensions in sixteenths (1/16).

examples:

$$08 = 8/16 = 1/2" \text{ Diameter}$$

$$16 = 16/16 = 1.0" \text{ Diameter}$$

$$24 = 24/16 = 1-1/2" \text{ Diameter}$$

M**Insert Holding****M**

Clamp and Lock Pin

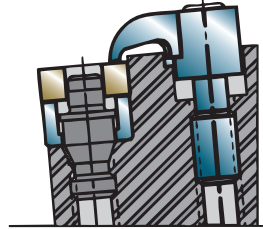
**S**

Screw Lock Only

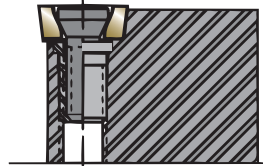
**C****Insert Shape****C**

Diamond

**D**

Diamond

**R**

Round

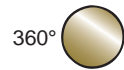
**S**

Square

**T**

Triangle

**V**

Diamond

**W**

Trigon



L

Boring Bar Style

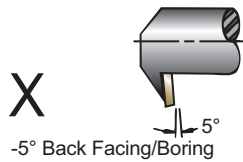
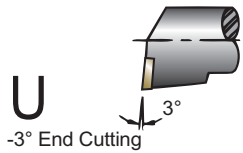
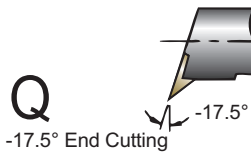
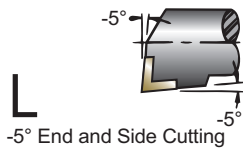
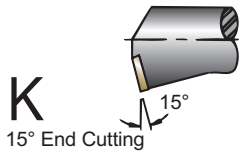
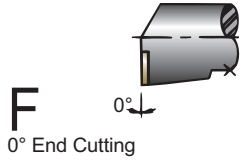

C

Insert Relief Angle

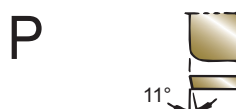
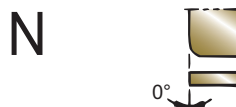
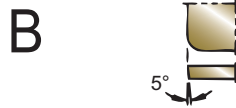

R

Hand

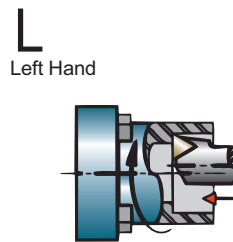
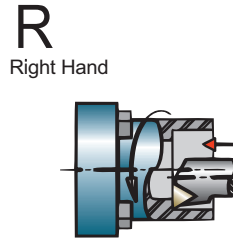

2

Insert Size

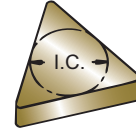

For equal sided inserts this indicates the inscribed circle (I.C.) in eighths (1/8).

examples,

$$6 = 6/8 = 3/4" \text{ I.C.}$$

$$4 = 4/8 = 1/2" \text{ I.C.}$$

$$2.5 = 2.5/8 = 5/16" \text{ I.C.}$$



Overview – Insert Holding Methods

T-Rex Boring Bars

- Available in the -LU, -GU and -SU chipbreakers with grades T2000Z, AC700G, AC2000, AC820P, AC830P, AC610M, and AC630M
- Rigid clamping system ensures accurate insert indexing
- Up to 2.5mm (0.100") depth of cut
- **Six** 55° cutting edges versus the standard **four** edges of a DNMG insert



ANSI Standard Combination Boring Bars with through coolant

- Proven lock pin for negative rake geometry inserts
- Ideal for unground, negative rake inserts or utility and precision ground inserts
- Available with integral coolant delivery

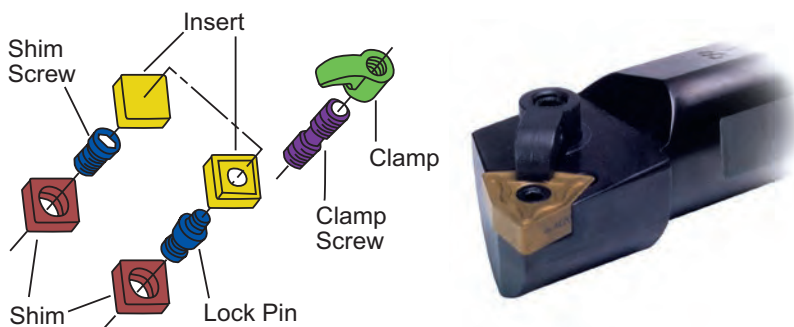

ANSI/ISO "Screw-On" Boring Bars

- Available with steel, carbide, or heavy metal shanks, ranging in size from 3/8" to 1" and coolant through the tool
- Designed to ISO-ANSI standards
- Uses TORX* insert holding screws
- Available with Anti-Vibration steel shanks



X-BAR Boring Bars

- Special dampener mechanism eliminates chatter
- Up to 6X L/D overhang (depth / bar diameter)
- Cost effective solution to carbide bars when deep hole boring
- Available in both coolant-through and non-coolant-through
- Effectively rough bores deep holes
- Bars available with CCMT, TCMT and TPMT style inserts



Sumitomo Design Boring Bars

- Styles available using negative inserts and 5°, 7°, 11° and 15° positive inserts
- For bores as small as .228" using the BSWJO design
- Available in steel or carbide shanks
- Various locking methods / unique Sumitomo designs

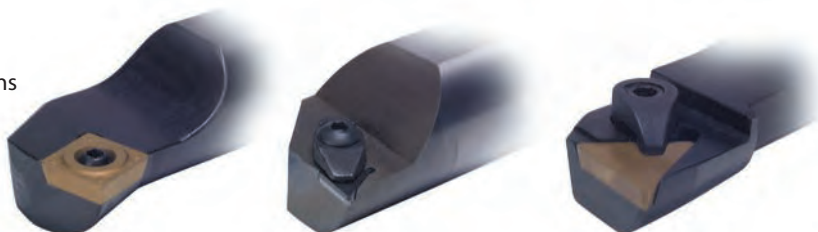

Features & Benefits

- Available in the -LU, -GU and -SU chipbreakers with grades T2000Z, AC700G, AC820P, AC830P, AC610M, and AC630M
- Rigid clamping system ensures accurate insert indexing
- Up to 2.5mm (0.100") depth of cut
- **Six** 55° cutting edges versus the standard **four** edges of a DNMG insert



T-REX Boring Bar

Sumitomo Cat. No.		Dimensions (Inch)					
Right Hand	Left Hand	D	C	F	H	K	Min. Bore
A20DTR55CR3	A20DTR55CL3	1.250"	10.000"	0.875"	0.309"	-12°	1.750"
-	A24DTR55CL3	1.500"	12.000"	1.000"	0.309"	-10°	2.000"

T-REX Inserts

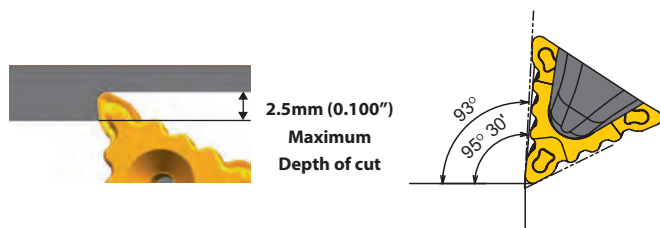

Please refer to page 70 for T-REX Inserts

Hardware

Clamp	Spring	Clamp Screw	Shim	Shim Screw	Wrench	Torx Wrench
TRCP3	SSP420	BX0520	TRW5505	BFTX0307N	TSW040	TRX10

Torque specifications for BX0520 clamp screw = 31-39 inch/lbs.

BORING BARS

Series: A-MCK • A-MCL

ANSI-ISO Boring Bars with through coolant

A-MCK								OPTIONAL HARDWARE						
Sumitomo Cat. No.			D	C	F	K°	Min. Bore	Shim	Lock Pin	Clamp	Clamp Screw	Shim Screw	Wrench	Wrench
Right Hand	Left Hand	Gage Insert												
A20MCKNR4	A20MCKNL4	CNMG432	1.250	14.000	.765	14°	1.470	ICSN433	NL46	CL20	XNS48	S46	LH3/32	LH030
A24MCKNR5	A24MCKNL5	CNMG543	1.500	14.000	.890	12°	1.760	ICSN-533	NL58	CL12	XNS510	S58	LH3/32	LH030

A-MCL								OPTIONAL HARDWARE						
Sumitomo Cat. No.			D	C	F	K°	Min. Bore	Shim	Lock Pin	Clamp	Clamp Screw	Shim Screw	Wrench	Wrench
Right Hand	Left Hand	Gage Insert												
A16MCLNR3	A16MCLNL3	CNMG322	1.000	12.000	.640	14°	1.200	N/A	NL-33	CL-7	XNS-36	-	-	-
A16MCLNR4	A16MCLNL4	CNMG432	1.000	12.000	.640	14°	1.200	N/A	NL-44	CL20	XNS48	-	LH3/32	LH030
A20MCLNR4	A20MCLNL4	CNMG432	1.250	12.000	.765	14°	1.470	ICSN433	NL46	CL20	XNS48	S46	LH3/32	LH030
A24MCLNR4	A24MCLNL4	CNMG432	1.500	14.000	.890	14°	1.760	ICSN433	NL-46	CL20	XNS47	S46	LH3/32	LH030
A28MCLNR4	A28MCLNL4	CNMG432	1.750	14.000	1.015	12°	2.010	ICSN433	NL-44	CL20	XNS48	S46	LH3/32	LH030
A32MCLNR4	A32MCLNL4	CNMG432	2.000	14.000	1.281	12°	2.400	ICSN433	NL-44	CL20	XNS48	S46	LH3/32	LH030
A32MCLNR5	A32MCLNL5	CNMG543	2.000	16.000	1.281	12°	2.400	ICSN533	NL58	CL12	XNS510	S58	LH030	LH040
A40MCLNR4	A40MCLNL4	CNMG432	2.500	16.000	1.531	10°	3.030	ICSN433	NL-44	CL20	XNS48	S46	LH3/32	LH030

Note: For right-handed boring bars, please use left-handed or neutral inserts. For left-handed boring bars, please use right-handed or neutral inserts



ANSI-ISO Boring Bars with through coolant

ANSI STANDARD COMBINATION **BORING BARS** Series: A-MDQ • A-MDU

Boring Bars

A-MDQ								OPTIONAL HARDWARE						
Sumitomo Cat. No.			D	C	F	K°	Min. Bore							
Right Hand	Left Hand	Gage Insert						Shim	Lock Pin	Clamp	Clamp Screw	Shim Screw	Wrench	Wrench
A20MDQNR4	A20MDQNL4	DNMG432	1.250	14.000	1.000	12°	1.705	IDSN433	NL46	CL20	XNS48	S46	LH3/32	LH030
A24MDQNR4	A24MDQNL4	DNMG432	1.500	14.000	1.125	8°	2.000	IDSN433	NL46	CL20	XNS48	S46	LH3/32	LH030

A-MDU								OPTIONAL HARDWARE						
Sumitomo Cat. No.			D	C	F	K°	Min. Bore							
Right Hand	Left Hand	Gage Insert						Shim	Lock Pin	Clamp	Clamp Screw	Shim Screw	Wrench	Wrench
A16MDUNR3	A16MDUNL3	DNMG332	1.000	12.000	.750	12°	1.300	N/A	NL-33	CL-7	XNS-36	S-34	N/A	N/A
A20MDUNR4	A20MDUNL4	DNMG432	1.250	14.000	1.000	10°	1.705	IDSN433	NL46	CL20	XNS48	S46	LH3/32	LH030
A24MDUNR4	A24MDUNL4	DNMG432	1.500	14.000	1.250	10°	2.000	IDSN433	NL46	CL20	XNS48	S46	LH3/32	LH030
A28MDUNR4	A28MDUNL4	DNMG432	1.750	14.000	1.250	10°	2.250	IDSN433	NL46	CL20	XNS48	S46	LH3/32	LH030
A32MDUNR4	A32MDUNL4	DNMG432	2.000	16.000	1.375	10°	2.500	IDSN533	NL58	CL12	XNS510	S58	LH030	LH040

Note: For right-handed boring bars, please use left-handed or neutral inserts. For left-handed boring bars, please use right-handed or neutral inserts



BORING BARS

Series: A-MTF • A-MVU

ANSI-ISO Boring Bars with through coolant

A-MTF								OPTIONAL HARDWARE						
Sumitomo Cat. No.			D	C	F	K°	Min. Bore							
Right Hand	Left Hand	Gage Insert						Shim	Lock Pin	Clamp	Clamp Screw	Shim Screw	Wrench	Wrench
A16MTFNR3	A16MTFNL3	TNMG332	1.000	12.000	.640	15°	1.200	N/A	NL-33L	CL20	XNS47	-	LH020	LH030
A20MTFNR3	A20MTFNL3	TNMG332	1.250	12.000	.765	12°	1.470	ITSN323	NL34L	CL20	XNS48	-	LH3/32	LH030
A24MTFNR3	A24MTFNL3	TNMG332	1.500	14.000	.890	10°	1.760	ITSN323	NL34L	CL20	XNS48	-	LH3/32	LH030
A24MTFNR4	A24MTFNL4	TNMG432	1.500	14.000	1.030	10°	1.900	ITSN433	NL46	CL20	XNS48	S46	LH3/32	LH030
A32MTFNR4	A32MTFNL4	TNMG432	2.000	14.000	1.281	8°	2.400	ITSN433	NL46	CL20	XNS48	S46	LH3/32	LH030

A-MVU								OPTIONAL HARDWARE					
Sumitomo Cat. No.			D	C	F	K°	Min. Bore						
Right Hand	Left Hand	Gage Insert						Shim	Lock Pin	Clamp	Clamp Screw	Wrench	Wrench
A20MVUNR3	A20MVUNL3	VNMG332	1.250	14.000	1.125	12°	1.705	IVSN322	NL34L	CL-22	XNS47	LH020	LH030
A24MVUNR3	A24MVUNL3	VNMG332	1.500	14.000	1.250	12°	2.250	IVSN322	NL34L	CL-22	XNS47	LH020	LH030

Note: For right-handed boring bars, please use left-handed or neutral inserts. For left-handed boring bars, please use right-handed or neutral inserts



ANSI-ISO Boring Bars with through coolant

ANSI STANDARD COMBINATION

BORING BARS

Series: A-MWL

A-MWL														
Sumitomo Cat. No.			D	C	F	K°	Min. Bore						OPTIONAL HARDWARE	
Right Hand	Left Hand												Wrench	Wrench
A12MWLNR3*	A12MWLNL3	WNMG332	.750	10.000	.500	14°	1.000	IWSN322	NL46	CL6	XNS36	N/A	LH3/32	LH020
A16MWLNR3	A16MWLNL3	WNMG332	1.000	12.000	.640	14°	1.200	IWSN322	NL46	CL6	XNS36	N/A	LH3/32	LH020
A16MWLNR4	A16MWLNL4	WNMG432	1.000	12.000	.640	14°	1.200	N/A	NL-44	CL20	XNS47	S46	LH3/32	LH030
A20MWLNR4	A20MWLNL4	WNMG432	1.250	12.000	.765	14°	1.470	IWSN433	NL46	CL20	XNS48	S46	LH3/32	LH030
A24MWLNR4	A24MWLNL4	WNMG432	1.500	14.000	.890	14°	1.760	IWSN433	NL46	CL20	XNS48	S46	LH3/32	LH030

*A=1/27-NPT for A12MWLNR3

Note: For right-handed boring bars, please use left-handed or neutral inserts. For left-handed boring bars, please use right-handed or neutral inserts



ANSI-ISO BORING BARS

Series: A-SCFP • A-SCLC

ANSI-ISO Boring Bars with through coolant

A-SCFP

Solid steel bar with coolant hole

Hardware when Boring Bar lot# begins with D####

Catalog Number		11° Positive Gage Insert	D	C	F	K°	Min. Bore	A	Insert Screw	Wrench	Insert Screw	Wrench
Right	Left											
A06SCFP2	-	CPMT21.51	.375	6.000	.250	4°	.480	1/8*	ST-1425	TRX07	ST21.5	TRX08
A08SCFP2	A08SCFPL2	CPMT21.51	.500	8.000	.312	2°	.600	1/16-27 NPT	ST-1425	TRX07	ST21.5	TRX08
A10SCFP2	A10SCFPL2	CPMT21.51	.625	10.000	.406	0°	.770	1/8-27 NPT	ST-1425	TRX07	ST21.5	TRX08
A12SCFP3	-	CPMT32.52	.750	10.000	.500	0°	.930	1/8-27 NPT	BFTX0407N	TRX15	ST32.5	-
A16SCFP3	-	CPMT32.52	1.000	12.000	.640	0°	1.200	1/4-18 NPT	BFTX0407N	TRX15	ST32.5	-

*Through hole only. No threads.

A-SCLC

Solid steel bar with coolant hole

Hardware when Boring Bar lot# begins with D####

Catalog Number		7° Positive Gage Insert	D	C	F	K°	Min. Bore	A	Insert Screw	Wrench	Insert Screw	Wrench
Right	Left											
A06SCLCR2	A06SCLCL2	CCMT21.51	.375	6.000	.250	-15°	.480	1/8*	ST-1425	TRX07	ST21.5	TRX08
A08SCLCR2	A08SCLCL2	CCMT21.51	.500	6.000	.312	-13°	.600	1/16-27 NPT	ST-1425	TRX07	ST21.5	TRX08
A10SCLCR2	A10SCLCL2	CCMT21.51	.625	8.000	.406	-10°	.770	1/8-27 NPT	ST-1425	TRX07	ST21.5	TRX08
A10SCLCR3	A10SCLCL3	CCMT32.52	.625	8.000	.406	-10°	.770	1/8-27 NPT	BFTX0407N	TRX15	ST32.5	-
A12SCLCR3	A12SCLCL3	CCMT32.52	.750	10.000	.500	-8°	.930	1/8-27 NPT	BFTX0407N	TRX15	ST32.5	-
A16SCLCR3	A16SCLCL3	CCMT32.52	1.000	12.000	.640	-7°	1.200	1/4-18 NPT	BFTX0407N	TRX15	ST32.5	-

*Through hole only. No threads.

Note: For right-handed boring bars, please use left-handed or neutral inserts. For left-handed boring bars, please use right-handed or neutral inserts



ANSI-ISO Boring Bars with through coolant

ANSI-ISO BORING BARS

Series: A-SCLP • A-SDUC

A-SCLP
Solid steel bar with coolant hole

Hardware when Boring Bar lot# begins with D####

Catalog Number			D	C	F	K°	Min. Bore	A				
Right	Left	11° Positive Gage Insert							Insert Screw	Wrench	Insert Screw	Wrench
A06SCLPR2	A06SCLPL2	CPMT21.51	.375	6.000	.250	-6°	.480	1/8*	ST-1425	TRX07	ST21.5	TRX08
A08SCLPR2	A08SCLPL2	CPMT21.51	.500	8.000	.312	-3°	.600	1/16-27 NPT	ST-1425	TRX07	ST21.5	TRX08
A10SCLPR2	A10SCLPL2	CPMT21.51	.625	10.000	.406	-2°	.770	1/8-27 NPT	ST-1425	TRX07	ST21.5	TRX08
A10SCLPR3	A10SCLPL3	CPMT32.52	.625	10.000	.406	-2°	.770	1/8-27 NPT	BFTX0407N	TRX15	ST32.5	-
A12SCLPR3	A12SCLPL3	CPMT32.52	.750	10.000	.500	-2°	.930	1/8-27 NPT	BFTX0407N	TRX15	ST32.5	-
A16SCLPR3	A16SCLPL3	CPMT32.52	1.000	12.000	.640	0°	1.200	1/4-18 NPT	BFTX0407N	TRX15	ST32.5	-

*Through hole only. No threads.

A-SDUC
Solid steel bar with coolant hole

Hardware when Boring Bar lot# begins with D####

Catalog Number			D	C	F	K°	Min. Bore	A				
Right	Left	7° Positive Gage Insert							Insert Screw	Wrench	Insert Screw	Wrench
A06SDUCR2	A06SDUCL2	DCMT21.51	.375	6.000	.375	-7°	.600	1/8*	ST-1425	TRX07	ST21.5	TRX08
A08SDUCR2	A08SDUCL2	DCMT21.51	.500	6.000	.437	-7°	.730	1/16-27 NPT	ST-1425	TRX07	ST21.5	TRX08
A10SDUCR2	A10SDUCL2	DCMT21.51	.625	8.000	.500	-7°	.850	1/8-27 NPT	ST-1425	TRX07	ST21.5	TRX08
A12SDUCR3	A12SDUCL3	DCMT32.52	.750	10.000	.562	-7°	.980	1/8-27 NPT	BFTX0407N	TRX15	ST32.5	-
A16SDUCR3	A16SDUCL3	DCMT32.52	1.000	12.000	.750	-5°	1.300	1/4-18 NPT	BFTX0407N	TRX15	ST32.5	-

*Through hole only. No threads.

Note: For right-handed boring bars, please use left-handed or neutral inserts. For left-handed boring bars, please use right-handed or neutral inserts



ANSI-ISO BORING BARS

Series: A-SDUP • A-SDXP

ANSI-ISO Boring Bars with through coolant

A-SDUP

Solid steel bar with coolant hole

Catalog Number		11° Positive Gage Insert	D	C	F	K°	Min. Bore	A	Hardware when Boring Bar lot# begins with D####			
Right	Left								Insert Screw	Wrench	Insert Screw	Wrench
A06SDUPR2	A06SDUPL2	DPMT21.51	.375	6.000	.375	-3°	.600	1/8*	ST-1425	TRX07	ST21.5	TRX08
A08SDUPR2	A08SDUPL2	DPMT21.51	.500	8.000	.437	-2°	.730	1/16-27 NPT	ST-1425	TRX07	ST21.5	TRX08
A10SDUPR2	-	DPMT21.51	.625	10.000	.500	0°	.850	1/8-27 NPT	ST-1425	TRX07	ST21.5	TRX08
A12SDUPR3	A12SDUPL3	DPMT32.52	.750	10.000	.562	0°	.980	1/8-27 NPT	BFTX0407N	TRX15	ST32.5	-
A16SDUPR3	A16SDUPL3	DPMT32.52	1.000	12.000	.750	0°	1.300	1/4-18 NPT	BFTX0407N	TRX15	ST32.5	-

*Through hole only. No threads.

A-SDXP

Solid steel bar with coolant hole

Catalog Number		11° Positive Gage Insert	D	C	F	L	K°	Min. Bore	A	Hardware when Boring Bar lot# begins with D####			
Right	Left									Insert Screw	Wrench	Insert Screw	Wrench
A08SDXPR2	A08SDXPL2	DPMT21.51	.500	8.000	.437	8-1/2	0°	.730	1/16-27 NPT	ST-1425	TRX07	ST21.5	TRX08
A10SDXPR2	A10SDXPL2	DPMT21.51	.625	10.000	.500	10-1/2	0°	.850	1/8-27 NPT	ST-1425	TRX07	ST21.5	TRX08
A12SDXPR3	A12SDXPL3	DPMT32.52	.750	10.000	.562	10-3/4	-2°	.980	1/8-27 NPT	BFTX0407N	TRX15	ST32.5	-
A16SDXPR3	A16SDXPL3	DPMT32.52	1.000	12.000	.750	12-3/4	0°	1.300	1/4-18 NPT	BFTX0407N	TRX15	ST32.5	-

Note: For right-handed boring bars, please use left-handed or neutral inserts. For left-handed boring bars, please use right-handed or neutral inserts



ANSI-ISO Boring Bars with through coolant

ANSI-ISO BORING BARS

Series: A-STFC • A-STFP

A-STFC

Solid steel bar
with coolant hole

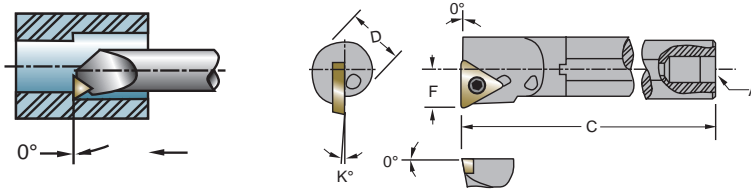

Hardware when
Boring Bar lot#
begins with D####

Catalog Number		7° Positive Gage Insert	D	C	F	K°	Min. Bore	A				
Right	Left											
A08STFCR2	A08STFCL2	TCMT21.51	.500	6.000	.312	-13°	.600	1/16-27 NPT	ST-1425	TRX07	ST21.5	TRX08
A10STFCR2	A10STFCL2	TCMT21.51	.625	8.000	.406	-10°	.770	1/8-27 NPT	ST-1425	TRX07	ST21.5	TRX08
A12STFCR3	A12STFCL3	TCMT32.52	.750	10.000	.500	-8°	.930	1/8-27 NPT	BFTX0407N	TRX15	ST32.5	-
A16STFCR3	A16STFCL3	TCMT32.52	1.000	12.000	.640	-7°	1.200	1/4-18 NPT	BFTX0407N	TRX15	ST32.5	-

A-STFP

Solid steel bar
with coolant hole

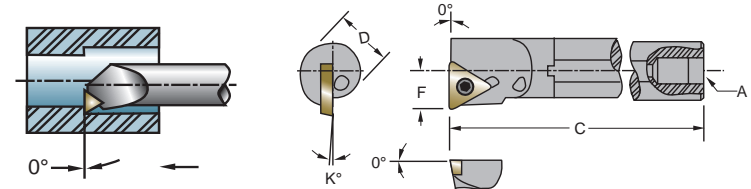

Hardware when
Boring Bar lot#
begins with D####

Catalog Number		11° Positive Gage Insert	D	C	F	K°	Min. Bore	A				
Right	Left											
A05STFPR1.8	A05STFPL1.8	TPMT1.81.51	.3125	5.000	.219	-8°	.415	3/32*	ST21.5	TRX08	-	-
A06STFPR2	A06STFPL2	TPMT21.51	.375	6.000	.250	-4°	.480	1/8*	ST-1425	TRX07	ST21.5	TRX08
A08STFPR2	A08STFPL2	TPMT21.51	.500	8.000	.312	-2°	.600	1/16-27 NPT	ST-1425	TRX07	ST21.5	TRX08
A10STFPR2	A10STFPL2	TPMT21.51	.625	10.000	.406	0°	.770	1/8-27 NPT	ST-1425	TRX15	ST21.5	TRX08
A12STFPR3	A12STFPL3	TPMT32.52	.750	10.000	.500	-2°	.930	1/8-27 NPT	BFTX0407N	TRX15	ST32.5	-
A16STFPR3	A16STFPL3	TPMT32.52	1.000	12.000	.640	0°	1.200	1/4-18 NPT	BFTX0407N	TRX15	ST32.5	-

*Through hole only. No threads.

Note: For right-handed boring bars, please use left-handed or neutral inserts. For left-handed boring bars, please use right-handed or neutral inserts



ANSI-ISO BORING BARS

Series: A-SVQB • A-SVUB

ANSI-ISO Boring Bars with through coolant

A-SVQB

Solid steel bar with coolant hole

Hardware when Boring Bar lot# begins with D####

Catalog Number		7° Positive Gage Insert	D	C	F	K°	Min. Bore	A	Insert Screw	Wrench	Insert Screw	Wrench
Right	Left											
A10SVQBR2	A10SVQBL2	VBMT221	.625	10.000	.500	-6°	.850	1/8-27 NPT	ST-21.5	TRX08	-	-
A12SVQBR2	A12SVQBL2	VBMT221	.750	10.000	.562	-5°	.980	1/8-27 NPT	ST-1425	TRX07	ST21.5	TRX08
A16SVQBR3	-	VBMT332	1.000	12.000	.640	-5°	1.300	1/4-18 NPT	BFTX0407N	TRX15	ST32.5	TRX15

A-SVUB

Solid steel bar with coolant hole

Hardware when Boring Bar lot# begins with D####

Catalog Number		11° Positive Gage Insert	D	C	F	K°	Min. Bore	A	Insert Screw	Wrench	Insert Screw	Wrench
Right	Left											
A12SVUBR2	A12SVUBL2	VBMT221	.750	10.000	.562	-6°	.980	1/8-27 NPT	ST-1425	TRX07	ST21.5	TRX08
A16SVUBR3	A16SVUBL3	VBMT332	1.000	12.000	.750	-6°	1.300	1/4-18 NPT	BFTX0407N	TRX15	ST32.5	TRX15
A20SVUBR3	A20SVUBL3	VBMT332	1.250	14.000	1.000	-6°	2.000	1/4-18 NPT	ST32.5	TRX15	-	-
A24SVUBR3	A24SVUBL3	VBMT332	1.500	14.000	1.250	-6°	2.250	1/4-18 NPT	ST32.5	TRX15	-	-

Note: For right-handed boring bars, please use left-handed or neutral inserts. For left-handed boring bars, please use right-handed or neutral inserts



A-SWLP
Solid steel bar with coolant hole

Hardware when Boring Bar lot# begins with D####

Catalog Number		7° Positive Gauge Insert	D	C	F	K°	Min. Bore	A	Insert Screw		Wrench	
Right	Left								Insert Screw	Wrench	Insert Screw	Wrench
A06SWLPR2	A06SWLPL2	WPMT1104	.375	6.000	.250	-5°	.480	1/8*	ST-1425	TRX07	ST21.5	TRX08
A08SWLPR2	A08SWLPL2	WPMT1104	.500	8.000	.312	-2°	.600	1/16-27 NPT	ST-1425	TRX07	ST21.5	TRX08
A10SWLPR2	-	WPMT1104	.625	10.000	.406	-3°	.770	1/8-27 NPT	ST-1425	TRX07	ST21.5	TRX08

*Through hole only. No threads.

S-STUP Series
For Internal Boring

Steel shank bar

These figures show right hand tools.

Sumitomo Cat. No.	STKD.		Dimensions							Insert		Screw	Wrench
	R	L	Min. Bore B	D	L	H	S	ℓ	θ°	Shape	Size		
S06K-STUPR/L6	•	•	.375	.375	5.000	.336	.1875	1.250	-10°	TPG□	63□	BFTY02205	TRX06
S06M-STUPR/L8	•	•	.500	.375	6.000	.336	.250	—	-8°	TPG□	21.5□	BFTX02507	TRX08
S08M-STUPR/L8	•	•	.625	.500	6.000	.461	.3125	—	-6°	TPG□	21.5□	BFTX02507	
S10Q-STUPR/L8	•	•	.750	.625	7.000	.591	.625	—	-2°	TPG□	21.5□	BFTX02507	
S12S-STUPR/L8	•	•	1.000	.750	10.000	.669	.500	—	-4°	TPG□	21.5□	BFTX02507	
S16T-STUPR/L8	•	•	1.125	1.000	12.000	.832	.5625	—	-2°	TPG□	21.5□	BFTX02507	

Maximum overhang = 5 x D

Note: For right-handed boring bars, please use left-handed or neutral inserts. For left-handed boring bars, please use right-handed or neutral inserts



S-STUB Series

For Internal Boring

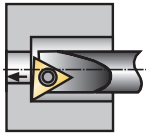

MIN BORE

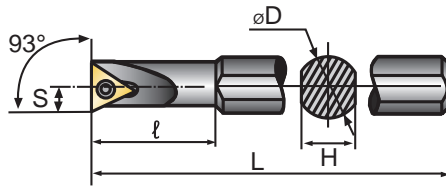

Steel shank bar



GAGE INSERT

TBGT52□



These figures show right hand tools.

Sumitomo Cat. No.	STKD.		Dimensions							Insert		Screw	Wrench
	R	L	Min. Bore B	D	L	H	S	l	θ°	Shape	Size		
S06K-STUBR/L5	•	•	.313	.375	5.000	.336	.156	1.0	-12°	TBG□	52□	BFTX0204A	TRX06

Maximum overhang = 5 x D



Finish-Medium Cut

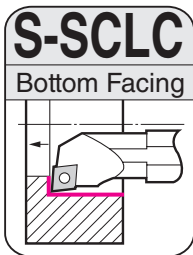

Steel

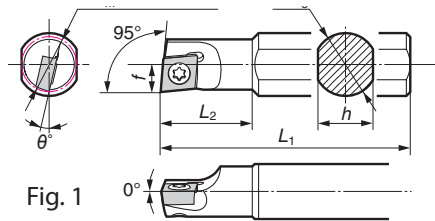
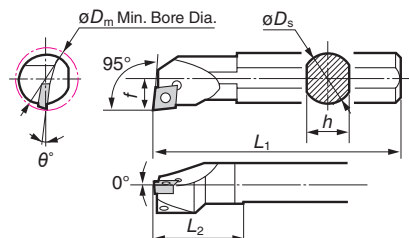

Fig. 1

Fig. 2



■ Spare Parts



(For Torx Holes)

■ Holder Right handed toolholders are applicable with left handed or neutral inserts. Left handed toolholders are applicable with right handed or neutral inserts. Above figures show right hand tools.

Shank	Cat. No.	Stock		Min. Bore Dia. øD _m	Dimensions (mm)						Fig.	Gage Insert	Screw	Recommended Tightening Torque (N•m)	Wrench
		R	L		øD _s	h	L ₁	f	L ₂	r _ε					
Steel	S08H-SCLC R/L03X1-05			5	8	7	100	2.5	24	-5	1	CC□□03X1□□	BFTX016033	0.2	TRX06
	S08H-SCLC R/L03X1-06			6	8	7	100	3.0	28	-13	1	CC□□04X1□□	BFTX0203N	0.5	
	S08H-SCLC R/L04X1-07			7	8	7	100	3.5	32	-13	1	CC□□04X1□□	BFTX02505N	1.1	
	S08H-SCLC R/L04X1-08			8	8	7	100	4.0	37	-11	1	CC□□04X1□□	BFTX02506N	1.5	TRX08
	S08H-SCLC R/L0602-10	★	★	10	8	7	100	5.5	19	-13	2	CC□□21.5□	BFTX0407N	3.0	
	S10K-SCLC R/L0602-12	★	★	12	10	9	125	6.0	21	-12	2	CC□□32.5□	BFTX0409N	3.4	TRX15
	S12M-SCLC R/L0602-14	★	★	14	12	11	150	7.0	25	-10	2	CC□□32.5□			
	S16R-SCLC R/L0602-18	★	★	18	16	15	200	9.0	27	-8	2	CC□□32.5□			
	S16R-SCLC R/L09T3-18	★	★	18	16	15	200	9.0	30	-10	2	CC□□32.5□			
	S20S-SCLC R/L09T3-22	★	★	22	20	18	250	11.0	30	-8	2	CC□□32.5□			
S25T-SCLC R/L09T3-27	★	★	27	25	23	300	13.5	35	-6	2	CC□□32.5□				

Note: For right-handed boring bars, please use left-handed or neutral inserts. For left-handed boring bars, please use right-handed or neutral inserts





Small Hole Finishing

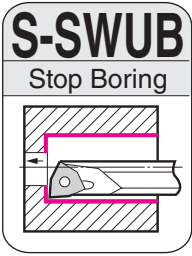

Steel

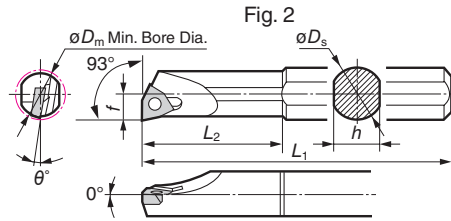
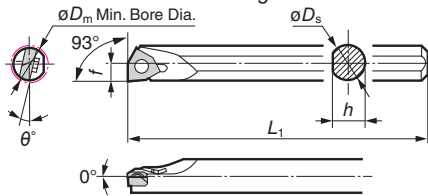

■ Spare Parts

■ **Holder**

Right handed toolholders are applicable with left handed or neutral inserts.
Left handed toolholders are applicable with right handed or neutral inserts.

Above figures show right hand tools.



(For Torx Holes)

Shank	Cat. No.	Stock		Dimensions (mm)							Fig.	Gage Insert	Screw	Recommended Tightening Torque (N•m)	Wrench
		R	L	Min. Bore Dia. øD _m	øD _s	h	L ₁	f	L ₂	θ°					
Steel	S05H-SWUB R/L0601-06K	★	★	5.5	5	4.7	100	2.75	-	-12	1	WB□□52 □	BFTX0203N	0.5	TRX06
	S08H-SWUB R/L0601-06	★	★	5.5	8	7.0	100	2.75	18	-12					
	S08H-SWUB R/L0601-08	★	★	8.0	8	7.0	100	4	30	-10	2	WB□□63 □	BFTX02205N	0.5	TRX06
	S08H-SWUB R/L0802-10	★	★	10.0	8	7.0	100	5	18	-13					
	S10K-SWUB R/L0802-12	★	★	12.0	10	9.0	125	6	20	-10					

S05H-SWUB R/L0601-06K needs adaptor sleeve (HBB516)

* Product will be marked with ISO Cat. No.

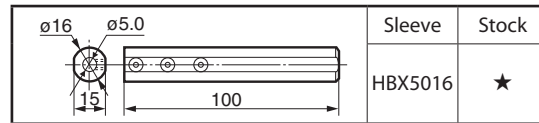

Sleeve

Stock

HBB516

★

Adaptor sleeve is optional

Small Hole Finishing

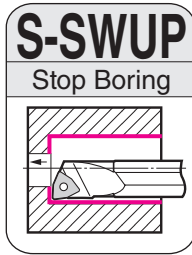

Steel

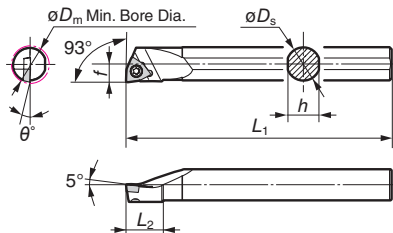

■ Spare Parts

■ **Holder**

Right handed toolholders are applicable with left handed or neutral inserts.
Left handed toolholders are applicable with right handed or neutral inserts.

Above figures show right hand tools.



(For Torx Holes)

Shank	Cat. No.	Stock		Dimensions (mm)							Gage Insert	Screw	Recommended Tightening Torque (N•m)	Wrench
		R	L	Min. Bore Dia. øD _m	øD _s	h	L ₁	f	L ₂	r _ε				
Steel	S12M-SWUP R/L1102-14	★		14	12	11	150	7	17	-6	WP□□1102□□	BFTX02505N	1.1	TRX08
	S16Q-SWUP R/L1102-18	★		18	16	15	180	9	18	-3				
	S16Q-SWUP R/L1603-18	★		18	16	15	180	9	18	-3	WP□□1603□□	BFTX0407N	3.4	TRX15
	S20R-SWUP R/L1603-22	★		22	20	18	200	11	18	-2				

■ **Insert** Coated: Yellow Cermet: Pink

-11° Relief M-Class

WPMT	LB	Cat. No.	Stock					Dimensions (mm)				
			AC820P	AC830P	AC6030M	AC6040M	T1500Z	T3000Z	T1500A	Inscribed circle	Thickness	Nose Radius
		WPMT 110204N-LB	★	★	★	★	★	★	★	6.35	2.38	0.4
		WPMT 160308N-LB	★	★	★	★	★	★	★	9.525	3.18	0.8



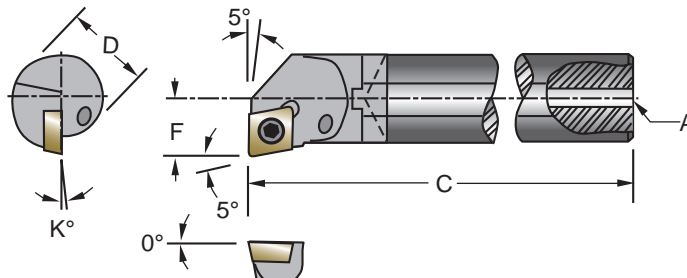
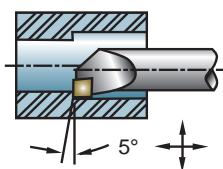

ISO-ANSI CARBIDE SHANK BORING BARS

E-SCLC - Inch



Solid carbide bar with fixed steel head and coolant hole

Sumitomo Cat. No.			D	C	F	K°	Min. Bore	A		
Right Hand	Left Hand	7° Positive Gage Insert							Insert Screw	Torx Wrench
E06MSCLCR2	E06MSCLCL2	CCMT21.51	.375	6.000	.250	-15°	.480	.093*	ST21.5	TRX08
E08RSCLCR2	E08RSCLCL2	CCMT21.51	.500	6.000	.312	-13°	.600	.093*	ST21.5	TRX08
E10SCLCR3	E10SCLCL3	CCMT32.52	.625	10.000	.406	-10°	.770	.125*	ST32.5	TRX15
E12SCLCR3	E12SCLCL3	CCMT32.52	.750	10.000	.500	-8°	.930	.142*	ST32.5	TRX15
E16TSCLCR3	E16SCLCL3	CCMT32.52	1.000	12.000	.640	-7°	1.200	.193*	ST32.5	TRX15

*Through hole only. No threads.

E-SCLC - Metric

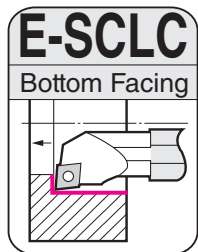

■ Holders

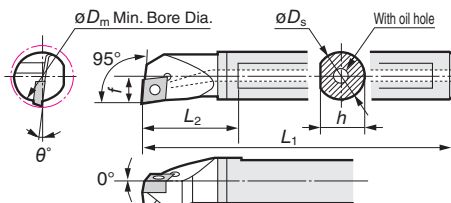

Right handed toolholders are applicable with left handed or neutral inserts.

■ Spare Parts

Shank	Cat. No.	Stock	Min. Bore Dia.	Dimensions (mm)						Gage Insert	Screw	Recommended Tightening Torque (N•m)	Wrench
				R	∅D _m	∅D _s	h	L ₁	f				
Carbide with oil hole	E08H-SCLC R0602-10	★	10	8	7.5	100	5.5	18	-13	CC□□21.5 □	BFTX02505N	1.1	TRX08
	E10K-SCLC R0602-13	★	13	10	9.5	125	7.0	19	-12		BFTX02506N	1.5	
	E12M-SCLC R0602-16	★	16	12	11.5	150	9.0	25	-10	CC□□32.5 □	BFTX0407N	3.4	TRX15
	E16R-SCLC R09T3-20	★	20	16	15.5	200	11.0	30	-8				

Note: For right-handed boring bars, please use left-handed or neutral inserts. For left-handed boring bars, please use right-handed or neutral inserts



ANSI-ISO Carbide Shank Boring Bars with through coolant

ANSI-ISO CARBIDE SHANK

BORING BARS

Series: E-STFC • E-STFP • C-STUB

Boring Bars

E-STFC		<p>Solid carbide bar with fixed steel head and coolant hole</p>									
Sumitomo Cat. No.		7° Positive Gage Insert	D	C	F	K°	Min. Bore	A	Insert Screw	Torx Wrench	
Right Hand	Left Hand										
E06STFCR2	E06STFCL2	TCMT21.51	.375	6.000	.250	-15°	.480	.093*	ST21.5	TRX08	
E08STFCR2	E08STFCL2	TCMT21.51	.500	6.000	.312	-13°	.600	.093*	ST21.5	TRX08	
E10STFCR2	E10STFCL2	TCMT21.51	.625	8.000	.406	-10°	.770	.125*	ST21.5	TRX08	
E12STFCR3	-	TCMT32.52	.750	10.000	.500	-8°	.930	.142*	ST32.5	TRX15	
E16STFCR3	-	TCMT32.52	1.000	12.000	.640	-7°	1.200	.193*	ST32.5	TRX15	

*Through hole only. No threads.

E-STFP		<p>Solid carbide bar with fixed steel head and coolant hole</p>									
Sumitomo Cat. No.		11° Positive Gage Insert	D	C	F	K°	Min. Bore	A	Insert Screw	Torx Wrench	
Right Hand	Left Hand										
E05STFPR1.8	E05STFPL1.8	TPMT1.81.51	.3125	5.000	.219	-8°	.415	.039	ST21.5	TRX08	

*Through hole only. No threads.

C-STUB Series		<p>Solid carbide bar with fixed steel head</p>												
Sumitomo Cat. No.		STKD.	Dimensions						Insert		Screw	Wrench	Replacement Head	
R	L		Min. Bore B	D	L	H	S	ℓ	θ°	Shape				Size
C06K-STUBR/L5		•	.313	.375	5.00	.336	.156	1.800	-12°	TBG□	52□	BFTX0204A	TRX06	RH06STUR/L5

These figures show right hand tools.

Maximum overhang = 7 x D



BORING BARS

Series: C-STUP • C-SCLC • C-SWUB

ANSI-ISO Carbide Shank Boring Bars with through coolant

Boring Bars

C-STUP Series

For Internal Boring

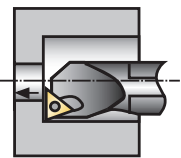

Maximum overhang = 7 x D

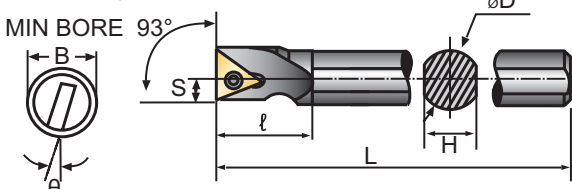

These figures show right hand tools. Solid carbide bar with fixed steel head



GAGE INSERT
TPG□□□

Sumitomo Cat. No.	STKD.		Dimensions							Insert		Screw	Wrench	Replacement Head
	R	L	Min. Bore B	D	L	H	S	ℓ	θ°	Shape	Size			
C06K-STUPR/L6	•	•	.375	.375	5.000	.336	.188	1.800	-10°	TPG□	63□	BFTX0204A	TRX06	RH06STUPR/L6
C06Q-STUPR/L8	•	•	.500	.375	7.000	.336	.250	—	-8°	TPG□	21.5□	BFTX02507	TRX08	RH06STUPR/L8
C08R-STUPR/L8	•	•	.625	.500	8.000	.461	.313	—	-6°	TPG□	21.5□	BFTX02507	TRX08	RH08STUPR/L8
C10S-STUPR/L8	•	•	.750	.625	10.000	.591	.375	—	-2°	TPG□	21.5□	BFTX02507	TRX08	RH10STUPR/L8
C12S-STUPR/L8	•	•	1.000	.750	10.000	.669	.500	—	-4°	TPG□	21.5□	BFTX02507	TRX08	RH12STUPR/L8

C-SCLC

Bottom Facing

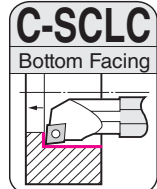

Carbide

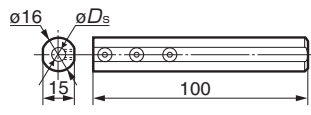

Fig. 1

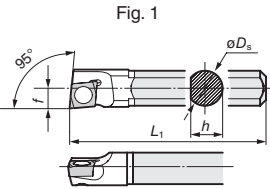
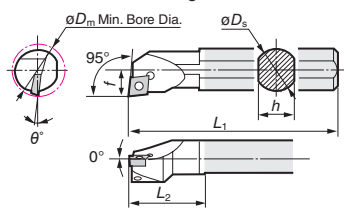

Fig. 2



Sleeve	Stock	∅Ds	Applicable Holder
HBX4016	★	4	C04G-SCLC R03X1-05*
HBX5016	★	5	C05H-SCLC R03X1-06*
HBX6016	★	6	C06J-SCLC R04X1-07*
HBB 716	★	7	C07K-SCLC R04X1-08*

* Requires the separately sold sleeve.

■ Holders

Right handed toolholders are applicable with left handed or neutral inserts.

■ Spare Parts



(For Torx Holes)

Shank	Cat. No.	Stock		Dimensions (mm)							Fig.	Gage Insert	Screw	Recommended Tightening Torque (N·m)	Wrench
		R	Min. Bore Dia. ∅Dm	∅Ds	h	L1	f	L2	re						
Carbide	C04G-SCLC R03X1-05*	★	5	4	3.8	90	2.5	Q	-15	1	CC□□03X1□□	BFTX016033	0.2	TRX06	
	C05H-SCLC R03X1-06*	★	6	5	4.4	100	3.0	Q	-13	1	CC□□04X1□□	BFTX0203N	0.5	TRX06	
	C06J-SCLC R04X1-07*	★	7	6	5.4	110	3.5	Q	-13	1	CC□□04X1□□	BFTX0203N	0.5	TRX06	
	C07K-SCLC R04X1-08*	★	8	7	6.4	125	4.0	Q	-11	1	CC□□04X1□□	BFTX0203N	0.5	TRX06	
	C08H-SCLC R0602-10	★	10	8	7.0	100	5.5	19	-13	2	CC21.5□	BFTX02505N	1.1	TRX08	
	C10K-SCLC R0602-12	★	12	10	9.0	125	6.0	21	-12						
	C10K-SCLC R0602-13	★	13	10	9.0	125	7.0	21	-12	2	CC21.5□	BFTX02506N	1.5	TRX08	
	C12M-SCLC R0602-14	★	14	12	11.0	150	7.0	25	-10						
	C12M-SCLC R0602-16	★	16	12	11.0	150	9.0	25	-10	2	CC□□32.5□	BFTX0407N	3.4	TRX15	
	C16R-SCLC R09T3-20	★	20	16	15.0	200	11.0	30	-8						
C20S-SCLC R09T3-25	★	25	20	18.0	250	13.0	35	-7	2	CC□□32.5□	BFTX0409N	3.4	TRX15		

C-SWUB

Stop Boring

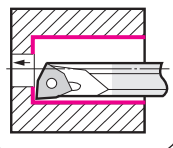

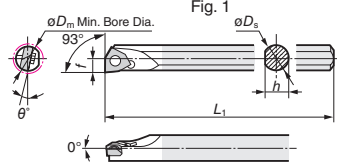

Fig. 1

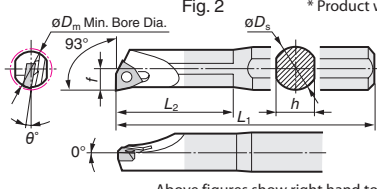

Fig. 2

Above figures show right hand tools.

Sleeve	Stock
HBX5016	★

Adaptor sleeve is optional

C05H-SWUB R/L0601-06K needs adaptor sleeve (HBB516)
* Product will be marked with ISO Cat. No.

■ Holders

Right handed toolholders are applicable with left handed or neutral inserts.
Left handed toolholders are applicable with right handed or neutral inserts.

■ Spare Parts



(For Torx Holes)

Shank	Cat. No.	Stock		Dimensions (mm)							Fig.	Gage Insert	Screw	Recommended Tightening Torque (N·m)	Wrench
		R	L	Min. Bore Dia. ∅Dm	∅Ds	h	L1	f	L2	θ°					
Carbide	C05H-SWUB R/L0601-06K	★	★	5.5	5	4.7	100	2.75	-	-12	1	WB□□52□	BFTX0203N	0.5	TRX06
	C08K-SWUB R/L0601-06	★	★	5.5	8	7.0	125	2.75	30	-12	2	WB□□52□	BFTX0203N	0.5	TRX06



■ Features & Benefits

- Special dampener mechanism eliminates chatter.
- Up to 6X L/D overhang (depth / bar diameter).
- Cost effective solution to carbide bars when deep hole boring.
- Available in both coolant-through and non-coolant-through
- Effectively rough bores deep holes.
- **NEW** negative X-Bars now available.
- Positive X-Bar expansion now includes bars for CC--, CP--, DC--, TC--, TP--, and VB-- style inserts.



■ X-BAR Technical Information

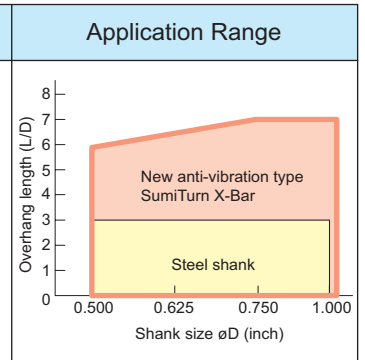
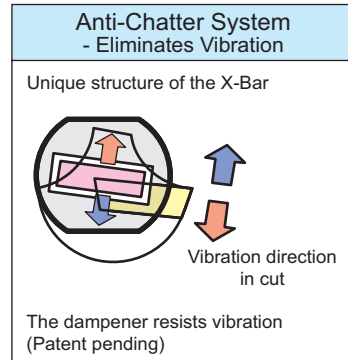
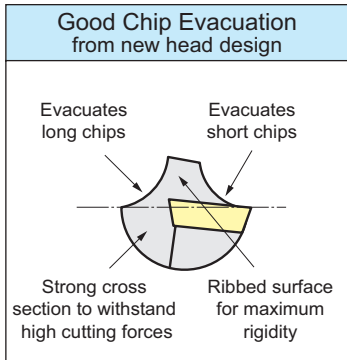

■ Recommended Overhang Length / Shank Diameter (L/D)

Chipbreakers	Type of Boring Bar	Overhang Length (L/D)						
		1	2	3	4	5	6	7
ELU, ESU, EMU (M class inserts) 	Steel shank 							
ELUW, Handed Wiper ("Wiper" style inserts) 	Steel shank 							

● "Wiper" Style Positive Inserts

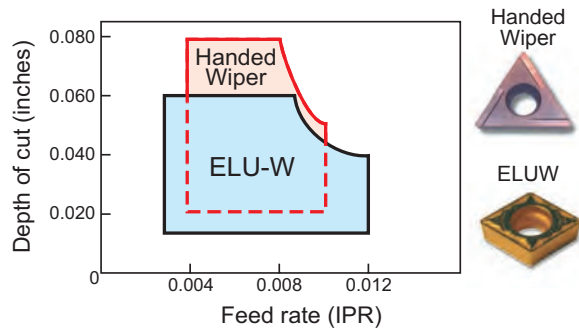

● M Class Positive Inserts

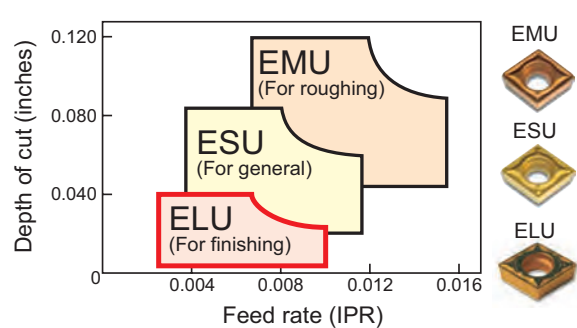



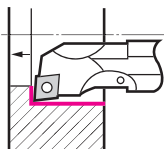

■ SumiTurn X-Bar Availability-POSITIVE

D-SCLC

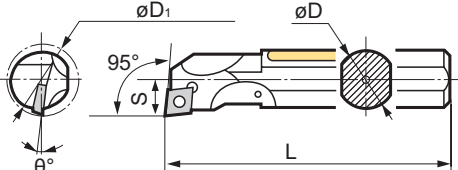







GAGE INSERT
CC□□

Sumitomo Cat. No.		Dimensions					Gage Insert	Hardware	
Right Hand	Left Hand	Min. Bore	D	L	S	θ°		Screw	Wrench
D08RSCLCR2	D08RSCLCL2	0.600"	0.500"	8"	0.300"	-10°	CC-21.5	BFTX02506N	TRX08
D10SSCLCR3	D10SSCLCL3	0.770"	0.625"	10"	0.385"	-8°	CC-32.5	BFTX0407N	TRX15
D12SSCLCR3	D12SSCLCL3	0.930"	0.750"	10"	0.465"	-7°	CC-32.5	BFTX0409N	TRX15
D16TSCLCR3	D16TSCLCL3	1.200"	1.000"	12"	0.600"	-6°	CC-32.5	BFTX0409N	TRX15

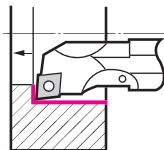
D-SCLP

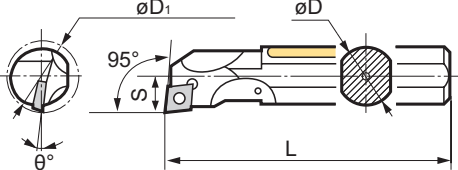







GAGE INSERT
CP□□

Sumitomo Cat. No.		Dimensions					Gage Insert	Hardware	
Right Hand	Left Hand	Min. Bore	D	L	S	θ°		Screw	Wrench
D10SSCLPR2		0.770"	0.625"	10"	0.355"	-5°	CP-21.5	BFTX02506N	TRX08
D12SSCLPR3	D12SSCLPL3	0.930"	0.750"	10"	0.450"	-4°	CP-32.5	BFTX0409N	TRX15
D16TSCLPR3	D16TSCLPL3	1.200"	1.000"	12"	0.550"	-2°	CP-32.5	BFTX0409N	TRX15

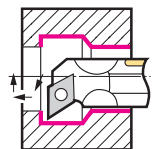
D/B-SDUC

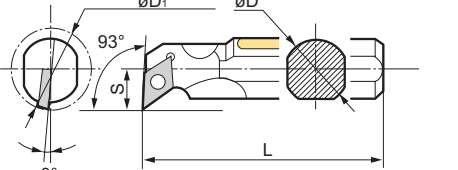





GAGE INSERT
DC□□

Sumitomo Cat. No.		Dimensions					Gage Insert	Hardware	
Right Hand	Left Hand	Min. Bore	D	L	S	θ°		Screw	Wrench
*B06RSDUCR2		0.600"	0.375"	8"	0.276"	-8°	DC-21.5	BFTX02506N	TRX08
D08RSDUCR2		0.730"	0.500"	8"	0.360"	-8°	DC-21.5	BFTX02506N	TRX08
D10SSDUCR2		0.850"	0.625"	10"	0.430"	-6°	DC-21.5	BFTX02506N	TRX08
D12SSDUCR3		0.980"	0.750"	10"	0.510"	-6°	DC-32.5	BFTX0409N	TRX15
D16TSDUCR3		1.300"	1.000"	12"	0.670"	-6°	DC-32.5	BFTX0409N	TRX15

*Non-coolant through

Note: For right-handed boring bars, please use left-handed or neutral inserts. For left-handed boring bars, please use right-handed or neutral inserts



Sumitomo Cat. No.		Dimensions					Gage Insert	Hardware	
Right Hand	Left Hand	Min. Bore	D	L	S	θ°	Insert	Screw	Wrench
D08RSTUCR2	D08RSTUCL2	0.600"	0.500"	8"	0.300"	-10°	TC-21.5	BFTX02506N	TRX08
D10SSTUCR2	D10SSTUCL2	0.770"	0.625"	10"	0.385"	-8°	TC-21.5	BFTX02506N	TRX08
D12SSTUCR3	D12SSTUCL3	0.930"	0.750"	10"	0.465"	-7°	TC-32.5	BFTX0409N	TRX15
D16TSTUCR3	D16TSTUCL3	1.200"	1.000"	12"	0.600"	-6°	TC-32.5	BFTX0409N	TRX15

Sumitomo Cat. No.		Dimensions					Gage Insert	Hardware	
Right Hand	Left Hand	Min. Bore	D	L	S	θ°	Insert	Screw	Wrench
D08RSTUPR2	D08RSTUPL2	0.600"	0.500"	8"	0.300"	-7°	TP-22	BFTX0306A	TRX10
D10SSTUPR2	D10SSTUPL2	0.770"	0.625"	10"	0.385"	-4°	TP-22	BFTX0306A	TRX10
D12SSTUPR2	D12SSTUPL2	0.930"	0.750"	10"	0.465"	-2°	TP-22	BFTX0307A	TRX10
D16TSTUPR3	D16TSTUPL3	1.200"	1.000"	12"	0.600"	-2°	TP-33	BFTX0410A	TRX15

Sumitomo Cat. No.		Dimensions					Gage Insert	Hardware	
Right Hand	Left Hand	Min. Bore	D	L	S	θ°	Insert	Screw	Wrench
D10SSVUBR2	D10SSVUBL2	0.850"	0.625"	10"	0.500"	-7.5°	VB-22	BFTX02506N	TRX08
D12SSVUBR2	D12SSVUBL2	0.980"	0.750"	10"	0.562"	-7.5°	VB-22	BFTX02506N	TRX08

Sumitomo Cat. No.		Dimensions					Gage Insert	Hardware	
Right Hand	Left Hand	Min. Bore	D	L	S	θ°	Insert	Screw	Wrench
D08RSVZBR2	-	0.800"	0.500"	8"	0.532"	-7.5°	VB-22	BFTX02506N	TRX08
D10SSVZBR2	-	1.000"	0.625"	10"	0.650"	-7.5°	VB-22	BFTX02506N	TRX08

Note: For right-handed boring bars, please use left-handed or neutral inserts. For left-handed boring bars, please use right-handed or neutral inserts

■ SumiTurn X-Bar Availability-NEGATIVE

D-DCLN								Hardware				
Sumitomo Cat. No.			D	C	F	K°	Min. Bore		Clamp Set	Wrench	Shim	Screw
Right Hand	Left Hand	Gage Insert										
D16TDCLNR4	D16TDCLNL4	CNMG432	1.000	12"	0.640	14°	1.250"				CNS1203B	BFTX0309N
D20TDCLNR4	D20TDCLNL4	CNMG432	1.250	12"	0.765	14°	1.470"	SCP-2	LH040 LH025		CNS1204B	BFTX0409N
D24UDCLNR4	D24UDCLNL4	CNMG432	1.500	12"	0.890	14°	1.760"				CNS1204B	BFTX0409N

D-DDQN								Hardware				
Sumitomo Cat. No.			D	C	F	K°	Min. Bore		Clamp Set	Wrench	Shim	Screw
Right Hand	Left Hand	Gage Insert										
D20TDDQNR4	-	DNMG432	1.250	12"	1.000	12°	1.705"				DNS1506B	BFTX0409N
D24UDDQNR4	-	DNMG432	1.500	12"	1.125	8°	2.000"	SCP-2	LH040 LH025			

D-DDUN								Hardware				
Sumitomo Cat. No.			D	C	F	K°	Min. Bore		Clamp Set	Wrench	Shim	Screw
Right Hand	Left Hand	Gage Insert										
D20TDDUNR4	-	DNMG432	1.250	12"	1.000	10°	1.705"				DNS1506B	BFTX0409N
D24UDDUNR4	-	DNMG432	1.500	12"	1.250	10°	2.000"	SCP-2	LH040 LH025			

Note: For right-handed boring bars, please use left-handed or neutral inserts. For left-handed boring bars, please use right-handed or neutral inserts



D-DVUN								Hardware			
Sumitomo Cat. No.			D	C	F	K°	Min. Bore				
Right Hand	Left Hand	Gage Insert						Clamp Set	Wrench	Shim	Screw
D20TDVUNR3	-	VNMG332	1.250	12"	1.125	12°	2.000"	SCP-2	LH040 LH025	VNS1604	BFTX0307N
D24UDVUNR3	-	VNMG332	1.500	12"	1.250	12°	2.350"				

D-DWLN								Hardware			
Sumitomo Cat. No.			D	C	F	K°	Min. Bore				
Right Hand	Left Hand	Gage Insert						Clamp Set	Wrench	Shim	Screw
D16TDWLN4	-	WNMG432	1.000	12"	0.640	14°	1.325"	SCP-2	LH040	WNS0804B	BFTX0409N
D20TDWLN4	-	WNMG432	1.250	12"	0.765	14°	1.470"	SCP-2	LH025		
D24UDWLN4	-	WNMG432	1.500	12"	0.890	14°	1.760"	SCP-2			



Note: For right-handed boring bars, please use left-handed or neutral inserts. For left-handed boring bars, please use right-handed or neutral inserts

SUMITOMO BORING BAR NOMENCLATURE



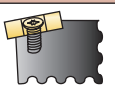
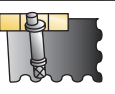

1 Type of Bar

Solid Steel	Solid Carbide
B	C





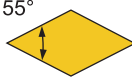
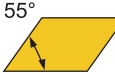
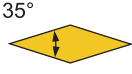

2 Clamping System

	
C Clamp Lock	M Multiple Lock
	
S Screw Clamp	
	
P Pin Lock	

3 Insert Shape



	
S	T
	
C	D
	
K	V
	
W	

4 Bar Style

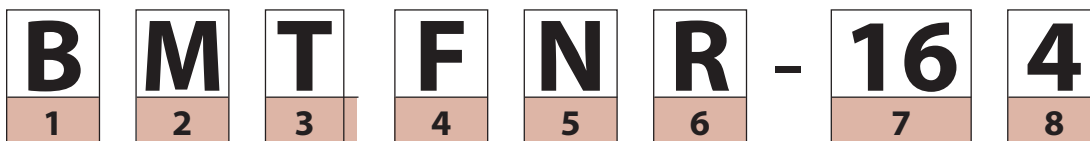

	
L	K
	
F	J
	
Q	H

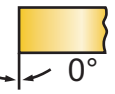

5 Rake Angle

	
N	P

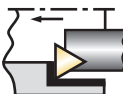
6 Hand of Tool

	
R	L

7 Bar Diameter

The two-digit number represents the Bar Diameter in 1/16 of an inch increments.

06 = 3/8	24 = 1 1/2	42 = 2 5/8
08 = 1/2	26 = 1 5/8	44 = 1 3/4
10 = 5/8	28 = 1 3/4	46 = 1 7/8
12 = 3/4	30 = 1 7/8	48 = 3
14 = 7/8	32 = 2	
16 = 1	34 = 2 1/8	
18 = 1 1/8	36 = 2 1/4	
20 = 1 1/4	38 = 2 3/8	
22 = 1 3/8	40 = 2 1/2	

8 Insert I.C. Size

I.C. Size in 1/8 inch increments.

Under 1/4 I.C.	Over 1/4 I.C.
2 = 5/16	2 = 1/4
5 = 5/32	3 = 3/8
6 = 3/16	4 = 1/2
	5 = 5/8
	6 = 3/4
	7 = 7/8
	8 = 1

Note: For right-handed boring bars, please use left-handed or neutral inserts. For left-handed boring bars, please use right-handed or neutral inserts



BMDLN Series
For Internal Boring

GAGE INSERT DNMG432

These figures show right hand tools.

Sumitomo Cat. No.	STKD.		Dimensions					Insert		Shim	Cam	Clamp	Clamp Screw	Wrench	Wrench
	R	L	Min. Bore B	D	L	S	H	Shape	Size						
BMDLNR/L 204	•	•	2.000	1.250	14.000	1.000	1.280	DN□□	43□	SDW423	CPB43	CCM8F-L	WB8F-20	LH030	LH040

BMSKN Series
For Internal Boring

GAGE INSERTS SNMG432

These figures show right hand tools.

Sumitomo Cat. No.	STKD.		Dimensions					Insert		Shim	Cam	Clamp	Clamp Screw	Wrench	Wrench
	R	L	Min. Bore B	D	L	S	H	Shape	Size						
BMSKNR/L 244	•	•	1.781	1.500	14.000	.890	1.480	SN□□	43□	SSW423	CPB43S	CCM8F	WB8F-30	LH030	LH040
BMSKNR/L 324	•	•	2.563	2.000	16.000	1.281	1.815				CPB43				

Maximum overhang=3 x D

BMCLN Series
For Internal Boring

GAGE INSERT CNMA432

These figures show right hand tools.

Sumitomo Cat. No.	STKD.		Dimensions					Insert		Shim	Cam	Clamp	Clamp Screw	Wrench	Wrench
	R	L	Min. Bore B	D	L	S	H	Shape	Size						
BMCLNR/L 244	•	•	1.781	1.500	14.000	.890	1.350	CN□□	43□	SCW423	CPB43S	CCM8F	WB8F-30	LH030	LH040
BMCLNR/L 284	•	•	2.031	1.750	14.000	1.015	1.615				CPB43				
BMCLNR/L 324	•	•	2.563	2.000	16.000	1.281	1.850								

Maximum overhang=3 x D

Note: For right-handed boring bars, please use left-handed or neutral inserts. For left-handed boring bars, please use right-handed or neutral inserts



BMWLN Series

For Internal Boring

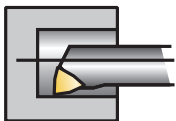

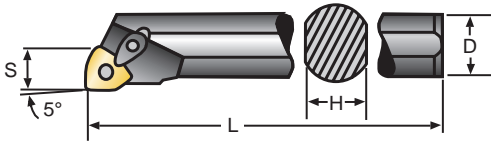

GAGE INSERT
WNMG432

These figures show right hand tools.

Sumitomo Cat. No.	STKD.		Dimensions						Insert		Wrench	Clamp	Pin	Shim	Screw
	R	L	Min. Bore B	D	L	S	H	θ°	Shape	Shape					
BMWLN/L 164	•	•	1.25	1.000	12.000	.625	.875	-15°	WN□□	43□	LH030	BCH05RM6L	BWP46	SWB422	WB6-16
BMWLN/L 204	•	•	1.53	1.250	14.000	.765	1.132	-14°	WN□□	43□	LH025	BCH05RM6L	BWP46	SWB422	WB6-16
BMWLN/L 244	•	•	1.78	1.500	14.000	.890	1.382	-12°	WN□□	43□	LH025	BCH05RM6L	BWP46	SWB422	WB6-16

Maximum overhang=3 x D

BSCLO Series

For Internal Boring

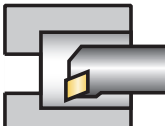

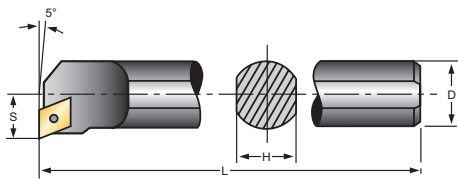

GAGE INSERT
CPGM□□□

These figures show right hand tools.

Sumitomo Cat. No.	STKD.		Dimensions						Insert		Screw	Wrench
	R	L	Min. Bore B	D	L	S	H	θ°	Shape	Size		
BSCLOR/L 062	•	•	.500	.375	6.000	.250	.336	-5°	CP□□	2.51.5□	BFTX0305A	TRX10
BSCLOR/L 082	•	•	.625	.500	6.000	.313	.462	-2°	CP□□	32□	BFTX0407A	TRX15
BSCLOR/L 103	•	•	.750	.625	6.500	.375	.586	-2°	CP□□	43□	BFTX0509A	TRX20
BSCLOR/L 123	•	•	1.000	.750	10.000	.500	.672	0°	CP□□	43□	BFTX0509A	TRX20
BSCLOR/L 164	•	•	1.125	1.000	12.000	.563	.882	-1°	CP□□	43□	BFTX0509A	TRX20

Maximum overhang = 3 x D

Note: For right-handed boring bars, please use left-handed or neutral inserts. For left-handed boring bars, please use right-handed or neutral inserts



BSDJO Series
For Internal Boring

GAGE INSERT
DCGT□□□

These figures show right hand tools.

Sumitomo Cat. No.	STKD.		Dimensions						Insert		Screw	Wrench
	R	L	Min. Bore B	D	L	S	H	θ°	Shape	Size		
BSDJOR/L 062	•	•	.516	.375	5.000	.306	.336	-6°	DC□□	21.5□	BFTX02506	TRX08
BSDJOR/L 082	•	•	.687	.500	6.000	.368	.461	-6°				
BSDJOR/L 102	•	•	.813	.625	8.000	.431	.586	-6°	DC□□	32.5□	BFS0410T	TRX10
BSDJOR/L 123	•	•	1.000	.750	10.000	.493	.671	-6°				

Maximum overhang = 3 x D

BSTJO Series
For Internal Boring

GAGE INSERT
T□GT□□□

These figures show right hand tools.

Sumitomo Cat. No.	STKD.		Dimensions						Insert		Screw	Wrench
	R	L	Min. Bore B	D	L	S	H	θ°	Shape	Size		
BSTJOR/L 065	•	•	.313	.375	5.000	.156	.336	-12°	TBG□	52□	BFTX0204A	TRX06
BSTJOR/L 066	•	•	.375	.375	5.000	.188	.336	-8°	TPG□	63□		
BSTJOR/L 062	•	•	.500	.375	6.000	.250	.336	-5°		22□	BFTX0306A BFTX0307A	TRX10
BSTJOR/L 082	•	•	.625	.500	6.000	.312	.462	-4°				
BSTJOR/L 102	•	•	.750	.625	6.500	.375	.586	-2°		33□	BFTX0410A	TRX15
BSTJOR/L 123	•	•	1.000	.750	10.000	.500	.672	-2°				
BSTJOR/L 163	•	•	1.125	1.000	12.000	.563	.882	0°				

Maximum overhang = 3 x D

BSSKO Series
For Internal Boring

GAGE INSERT
SPGG322L

These figures show right hand tools.

Sumitomo Cat. No.	STKD.		Dimensions						Insert		Screw	Wrench
	R	L	Min. Bore B	D	L	S	H	θ°	Shape	Size		
BSSKOR/L 083	•	•	.625	.500	6.000	.312	.462	-4°	SP□□	32□	BFTX0307A	TRX10
BSSKOR/L 103	•	•	.750	.625	6.500	.375	.586	-2°				
BSSKOR/L 123	•	•	1.000	.750	10.000	.500	.672	0°				
BSSKOR/L 163	•	•	1.125	1.000	12.000	.563	.882	0°				

Maximum overhang = 3 x D

Note: For right-handed boring bars, please use left-handed or neutral inserts. For left-handed boring bars, please use right-handed or neutral inserts



BCTJP Series

For Internal Boring

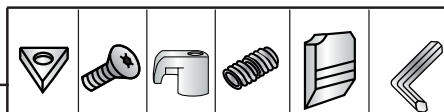
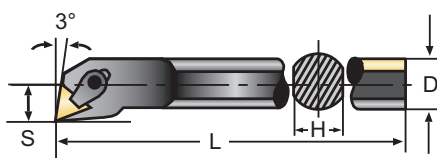
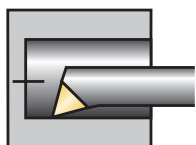

These figures show right hand tools.

Sumitomo Cat. No.	STKD.		Dimensions				Insert		Seat	Seat Screw	Clamp	Clamp Bolt	Chip Breaker Piece	Wrench	
	R	L	Min. Bore B	D	L	S	H	Shape							Size
BCTJPR 123	•		1.000	.750	12.000	.500	.770	TPG	32□	STPD322	BF0308	CCM6BR/L	WB6-13	CBT23	
BCTJPR/L 163	•		1.156	1.000	12.000	.578	.980						WB6-16	LH030	
BCTJPR/L 203	•	•	1.531	1.250	14.000	.765	1.100						CBT43		
BCTJPR/L 243	•		1.781	1.500	14.000	.890	1.315								
BCTJPR 283	•		2.031	1.750	14.000	1.015	1.570								
BCTJPR 404	•		3.063	2.500	16.000	1.531	2.315	TPG	43□	STPD422		CCM8F	WB8F-30	CBT44	LH040

Maximum overhang = 3 x D

BSWJO Series

For Internal Boring

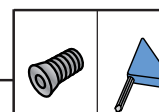
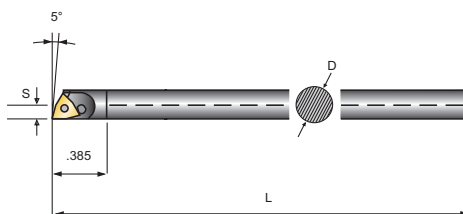
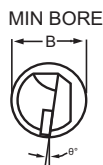
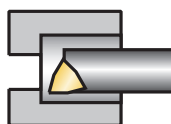

These figures show right hand tools.

Sumitomo Cat. No.	STKD.	Dimensions							Insert	Screw	Wrench
		Min. Bore B	D	H	L	S	θ°	ℓ			
BSWJOR 035	•	.228	.187	-	2.500	.062	-12°	-	WBGT 52□L	BFTX0203A	TRX06

Maximum overhang = 5 x D

Note: For right-handed boring bars, please use left-handed or neutral inserts. For left-handed boring bars, please use right-handed or neutral inserts



CSCLO Series
For Internal Boring

Solid carbide bar with fixed steel head

GAGE INSERT
CPGT□□□

These figures show right hand tools.

Sumitomo Cat. No.	STKD.		Dimensions						Insert		Screw	Wrench
	R	L	Min. Bore B	D	L	S	H	θ°	Shape	Size		
CSCLO/L 062	•	•	.500	.375	6.000	.250	.336	-5°	CP□T	2.51.5□	BFTX0305A	TRX10
CSCLO/L 082	•	•	.625	.500	6.000	.313	.462	-2°	CP□T	32□	BFTX0407A	TRX15
CSCLO/L 103	•	•	.750	.625	6.500	.375	.586	-2°	CP□T	32□	BFTX0407A	TRX15

Maximum overhang = 5 x D

CSTJO Series
For Internal Boring

Solid carbide bar with fixed steel head

GAGE INSERT
TB□T□□□

These figures show right hand tools.

Sumitomo Cat. No.	STKD.		Dimensions							Insert		Screw	Wrench
	R	L	Min. Bore B	D	L	S	H	ℓ	θ°	Shape	Size		
CSTJOR/L 065	•	•	.313	.375	5.000	.1560	.336	1.781	-12°	TB□T	52□	BFTX0204A	TRX06
CSTJOR/L 066	•	•	.375	.375	5.000	.1880	.336	1.781	-8°	TB□T	63□	BFTX0306A	
CSTJOR/L 062	•	•	.500	.375	7.000	.2500	.336	-	-5°	TPG□	22□	BFTX0307A	TRX10
CSTJOR/L 082	•	•	.625	.500	8.000	.3125	.462	-	-2°		22□	BFTX0307A	
CSTJOR/L 102	•	•	.750	.625	10.000	.3750	.586	-	-2°		33□	BFTX0410A	TRX15
CSTJOR/L 123	•	•	1.000	.750	10.000	.5000	.672	-	-2°		33□	BFTX0410A	

Maximum overhang = 5 x D

CSWJO Series
For Internal Boring

Solid carbide bar with fixed steel head

GAGE INSERT
WB□T52□

These figures show right hand tools.

Sumitomo Cat. No.	STKD.	Dimensions						Insert	Screw	Wrench	
		Min. Bore B	D	H	L	S	θ°				ℓ
CSWJOR 055	•	.234	.375	.276	5.000	.117	-12°	1.18	WBG□ 52□L	BFTX0203A	TRX06
CSWJOL 055	•	.234							WBG□ 52□R		

Maximum overhang = 5 x D

Note: For right-handed boring bars, please use left-handed or neutral inserts. For left-handed boring bars, please use right-handed or neutral inserts



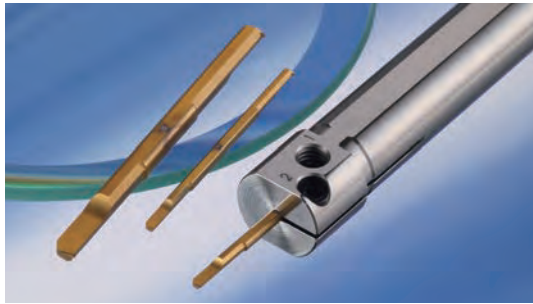

Small Hole Finishing

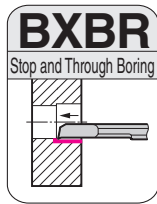

Characteristics

- Economical, two-cornered insert.
- Maximum boring depth 5D (5 times the shank diameter)
- Usable at any desired overhang.
- Shank size = min. bore diameter for easy selection.
(Available from $\phi 2$ mm to $\phi 5$ mm in 0.5 mm increments.)
- KBMX Type cutting edge used, no breaker versions also available in stock.

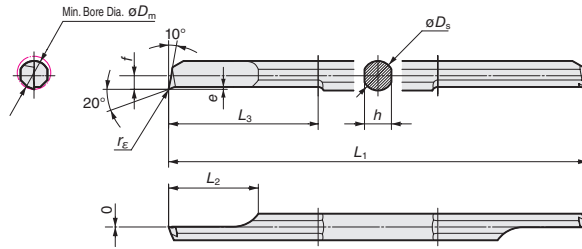
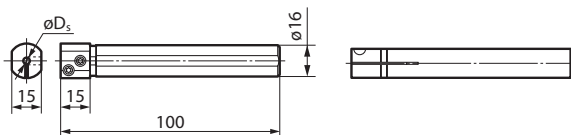

Figure shows tool with breaker.

Brazed Boring Bar

	Catalog Number	Stock	*Min. Bore Dia.	Dimensions (mm)								Applicable Sleeve
		ACZ150	ϕD_m	ϕD_s	h	L ₁	f	L ₂	L ₃	e	r _E	
With Breaker	BXBR 02005R	★	2.0	2.0	1.8	50	0.80	6.0	10.0	0.20	0.05	HBX 2016
	BXBR 02020R	★	2.0	2.0	1.8	50	0.80	6.0	10.0	0.20	0.20	HBX 2016
	BXBR 02505R	★	2.5	2.5	2.2	50	1.05	7.5	12.5	0.20	0.05	HBX 2516
	BXBR 02520R	★	2.5	2.5	2.2	50	1.05	7.5	12.5	0.20	0.20	HBX 2516
	BXBR 03005R	★	3.0	3.0	2.7	50	1.30	9.0	15.0	0.25	0.05	HBX 3016
	BXBR 03020R	★	3.0	3.0	2.7	50	1.30	9.0	15.0	0.25	0.20	HBX 3016
	BXBR 03505R	★	3.5	3.5	3.1	60	1.55	10.5	17.5	0.25	0.05	HBX 3516
	BXBR 03520R	★	3.5	3.5	3.1	60	1.55	10.5	17.5	0.25	0.20	HBX 3516
	BXBR 04005R	★	4.0	4.0	3.6	60	1.80	12.0	20.0	0.35	0.05	HBX 4016
	BXBR 04020R	★	4.0	4.0	3.6	60	1.80	12.0	20.0	0.35	0.20	HBX 4016
	BXBR 04505R	★	4.5	4.5	4.1	70	2.05	13.5	22.5	0.35	0.05	HBX 4516
	BXBR 04520R	★	4.5	4.5	4.1	70	2.05	13.5	22.5	0.35	0.20	HBX 4516
	BXBR 05005R	★	5.0	5.0	4.5	70	2.30	15.0	25.0	0.40	0.05	HBX 5016
	BXBR 05020R	★	5.0	5.0	4.5	70	2.30	15.0	25.0	0.40	0.20	HBX 5016
	No Breaker	BXBR 02005R-NB	★	2.0	2.0	1.8	50	0.80	6.0	10.0	0.20	0.05
BXBR 02020R-NB		★	2.0	2.0	1.8	50	0.80	6.0	10.0	0.20	0.20	HBX 2016
BXBR 02505R-NB		★	2.5	2.5	2.2	50	1.05	7.5	12.5	0.20	0.05	HBX 2516
BXBR 02520R-NB		★	2.5	2.5	2.2	50	1.05	7.5	12.5	0.20	0.20	HBX 2516
BXBR 03005R-NB		★	3.0	3.0	2.7	50	1.30	9.0	15.0	0.25	0.05	HBX 3016
BXBR 03020R-NB		★	3.0	3.0	2.7	50	1.30	9.0	15.0	0.25	0.20	HBX 3016
BXBR 03505R-NB		★	3.5	3.5	3.1	60	1.55	10.5	17.5	0.25	0.05	HBX 3516
BXBR 03520R-NB		★	3.5	3.5	3.1	60	1.55	10.5	17.5	0.25	0.20	HBX 3516
BXBR 04005R-NB		★	4.0	4.0	3.6	60	1.80	12.0	20.0	0.35	0.05	HBX 4016
BXBR 04020R-NB		★	4.0	4.0	3.6	60	1.80	12.0	20.0	0.35	0.20	HBX 4016
BXBR 04505R-NB		★	4.5	4.5	4.1	70	2.05	13.5	22.5	0.35	0.05	HBX 4516
BXBR 04520R-NB		★	4.5	4.5	4.1	70	2.05	13.5	22.5	0.35	0.20	HBX 4516
BXBR 05005R-NB		★	5.0	5.0	4.5	70	2.30	15.0	25.0	0.40	0.05	HBX 5016
BXBR 05020R-NB		★	5.0	5.0	4.5	70	2.30	15.0	25.0	0.40	0.20	HBX 5016

* Boring depth L₃ or less.



Adaptor Sleeve

Cat. No.	Stock	Dimensions (mm)	Applicable Bar
		ϕD_s	
HBX 2016	★	2.0	BXBR 020SSR(-NB)
HBX 2516	★	2.5	BXBR 025SSR(-NB)
HBX 3016	★	3.0	BXBR 030SSR(-NB)
HBX 3516	★	3.5	BXBR 035SSR(-NB)
HBX 4016	★	4.0	BXBR 040SSR(-NB)
HBX 4516	★	4.5	BXBR 045SSR(-NB)
HBX 5016	★	5.0	BXBR 050SSR(-NB)

* BXBR bars can be used with HBB type sleeves. Commercially available sleeves may also be used.

Spare Parts (For sleeve)

			Applicable Sleeve
Screw	Setting Screw	Wrench	
BFTX0409N	BT06035T	TRD15	HBX_____

* Adaptor sleeve is optional



CBN Boring Series

- Solid carbide shank and head adds rigidity.
- Max. overhang, $L = 5 \times D$
- Minimal bar deformation produces excellent boring accuracy.
- Minimal vibration produces a superior surface finish.

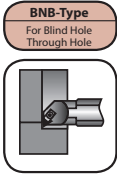
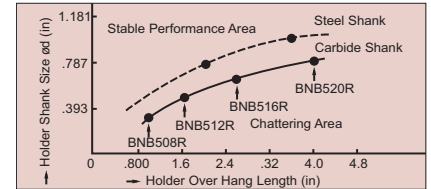
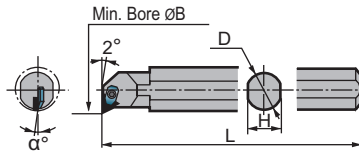

Sumitomo Cat. No.	Dimensions						Hardware				Insert		
	Right Hand	Min. Bore øB	D	L	H	α°	Clamp	Clamp Screw	Wrench	Nut	I.C.	Thick	Cat. No.
BNB508R		.394" (10mm)	.315" (8mm)	5.5" (140mm)	.275" (7mm)	-9°	BNBC	BH0306	TH020	BNB W2	.156	.125	TBGE52-
BNB512R		.591" (15)	.472" (12)	6.3" (160)	.433" (11)	-6°				BNB W4			
BNB516R		.787" (20)	.630" (16)	7" (180)	.551" (14)	-5°				BNB W7			
BNB520R		.984" (25)	.787" (20)	7" (180)	.709" (18)	-4°							

* BNB boring bars are 100% solid carbide (head and shank).

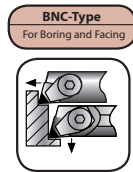

Sumitomo Cat. No.	Dimensions						Hardware				Insert		
	Right Hand	Min. Bore øB	D	L	H	α°	Clamp	Clamp Screw	Wrench	Nut	I.C.	Thick	Cat. No.
BNC508R		.394" (10mm)	.315" (8mm)	5.5" (140mm)	.275" (7mm)	-9°	BNBC	BH0306	TH020	BNB W2	.1875	.125	NU-CCGE62-
BNC510R		.472" (12)	.394" (10)	5.5" (140)	.35" (9)	-8°				BNB W4			
BNC512R		.591" (15)	.472" (12)	6.3" (160)	.433" (11)	-6°				BNB W7			
BNC516R		.787" (20)	.630" (16)	7" (180)	.551" (14)	-5°							
BNC520R		.984" (25)	.787" (20)	7" (180)	.709" (18)	-4°							

* BNC boring bars are 100% solid carbide (head and shank).

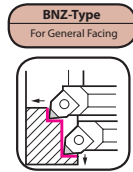

Sumitomo Cat. No.	Dimensions (mm)						
	Cat. Number	Stock	Min. Bore øDm	øDs	h	L1	θ°
BNZ606R	•	7.0	6.0	5.5	80	-14	
BNZ608R	•	9.0	8.0	7.5	100	-12	
BNZ610R	•	11.0	10.0	9.5	125	-10	
BNZ612R	•	13.0	12.0	11.0	130	-8	
BNZ616R	•	17.0	16.0	15.0	145	-6	
BNZ620R	•	21.0	20.0	19.0	160	-5	

Adapter Sleeve for BNZ type

	Sleeve	Stock	øDs	Applicable Holder
	HBB 616	○	6	BNZ 606R
HBB 816	○	8	BNZ 608R	

★ = Worldwide Warehouse item • = USA stocked item



BNBX Small Hole Brazed Boring Bar

Catalog No.	BN250	BN700	BN2000	BN7000	Min. Boring Dia.	Dimensions (mm)				Applicable Adapter Sleeve	ød (mm)
						øD	H	L	R		
BNBX020R	★	★	★	★	2.5	2.0	1.7	40	0.2	HBX2016	2.0
BNBX025R	★	★	★	★	3.0	2.5	2.2	40	0.2	HBX2516	2.5
BNBX030R	★	★	★	★	3.5	3.0	2.7	40	0.2	HBX3016	3.0
BNBX035R	★	★	★	★	4.0	3.5	3.2	40	0.2	HBX3516	3.5
BNBX040R	★	★	★	★	4.5	4.0	3.7	40	0.2	HBX4016	4.0
BNBX045R	★	★	★	★	5.0	4.5	4.2	40	0.2	HBX4516	4.5
BNBX050R	★	★	★	★	5.5	5.0	4.7	60	0.2	HBX5016	5.0
BNBX055R	★	★	★	★	6.0	5.5	5.2	60	0.2	HBX5516	5.5
BNBX060R	★	★	★	★	6.5	6.0	5.7	60	0.2	HBX6016	6.0
BNBX065R	★	★			7.0	6.5	6.2	60	0.2	HBB6516	6.5
BNBX070R	★	★			7.5	7.0	6.7	80	0.2	HBB716	7.0
BNBX075R	★	★			8.0	7.5	7.2	80	0.2	HBB7516	7.5
BNBX080R	★	★			8.5	8.0	7.7	80	0.2	HBB816	8.0

Adapter Sleeve Hardware

Screw	Setting Screw	Wrench	Applicable Sleeve
BFTX0409N	BT06035T	TRD15	HBX○○○○
-	BT0404	TH020	HBB○○○○

NOTE: BNBX bars can be used with HBB type sleeves, however, HBX type sleeves are recommended for bars below ø6mm

★ = Worldwide Warehouse Item

SUMIBORON Mini Boring Bars SJB Series

Jig Boring Tools

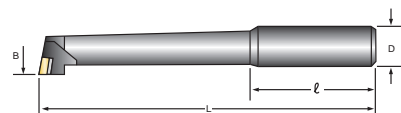

These figures show right hand tools.

Sumitomo Cat. No.	Dimensions (Inches)				Grade
	Min. Bore B	D	L	l	BN250
SJB2416	.250	.375	2.000	1.1875	•
SJB2420	.3125	.375	2.375	1.1875	•
SJB2424	.375	.375	2.750	1.1875	•
SJB2432	.500	.375	2.750	1.1875	•
SJB2440	.625	.375	3.750	1.1875	•

• = USA stocked item

Sumitomo Cat. No.	Dimensions (mm)				Grade
	øD	ød	L	l	BN250
SJB0804	8	4	45	32	★
SJB0805	8	5	45	32	★
SJB0806	8	6	50	30	★
SJB0808	8	8	60	30	★
SJB1006	10	6	50	30	★
SJB1008	10	8	60	30	★
SJB1010	10	10	70	30	★
SJB1012	10	12	70	30	★
SJB1015	10	15	70	30	★

★ = Worldwide Warehouse item

Recommended Cutting Conditions

Rotating speed	800 rpm, or more	Low speed may cause chattering and chipping on the cutting edge
Depth of cut	.001~.012 in./per side	Excessive depth of cut may cause larger tool deflection resulting in deterioration of bore size
Feed rate (f)	.001~.004 in. IPR	—

NOTE

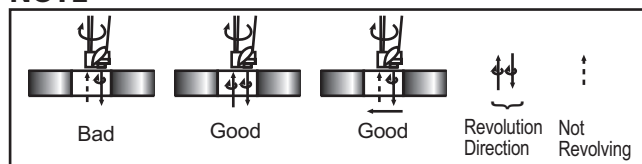

Either rotate the tool when removing or pull the tool away from work piece.





SUMIBORON

■ **Characteristics**

- Achieves the minimum bore diameter of $\phi 2.5\text{mm}$ in the boring of hardened steel.
- Achieves high-precision cutting edge positioning thanks to the newly-developed clamp mechanism
- Expands the range of small hole boring to achieve more high-efficiency machining requiring no grinding.
- Brazed BSME: Applicable to bore diameters ranging from $\phi 2.5$ to 5.0mm
- SEXC with indexable insert: Applicable to bore diameters ranging from $\phi 4.0$ to 6.0mm

* All items are available 2-3 weeks of purchase

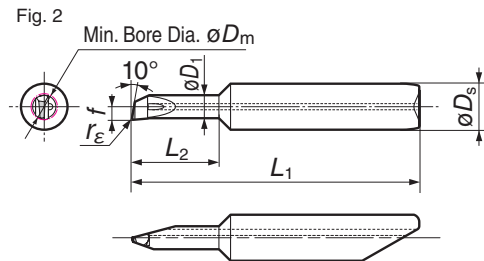
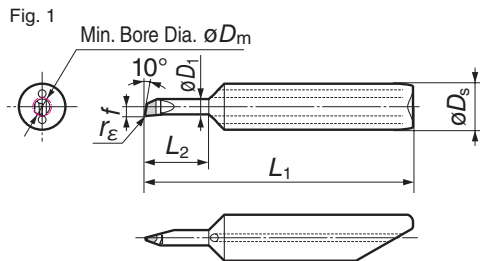
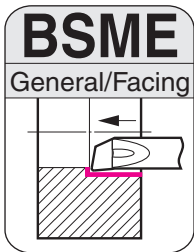

■ **Brazed Boring Bar**

Cat. No.	Stock		Min. Bore Dia. ϕD_m	Dimensions (mm)						Fig.	Applicable Sleeve
	BN2000			ϕD_s	ϕD_1	L_1	f	L_2	O		
	R	L	ϕD_m								
BSME R/L25020D2S6			2.5	6.0	2.0	32.0	1.20	5.3	0.2	1	HBSM6020
BSME R/L25020D3S6			2.5	6.0	2.0	34.5	1.20	7.8	0.2		
BSME R/L25020D4S6			2.5	6.0	2.0	37.0	1.20	10.3	0.2		
BSME R/L30020D2S6			3.0	6.0	2.5	32.8	1.45	6.3	0.2		
BSME R/L30020D3S6			3.0	6.0	2.5	35.8	1.45	9.3	0.2		
BSME R/L30020D4S6			3.0	6.0	2.5	38.8	1.45	12.3	0.2		
BSME R/L35020D2S6			3.5	6.0	3.0	33.5	1.70	7.3	0.2	2	
BSME R/L35020D3S6			3.5	6.0	3.0	37.0	1.70	10.8	0.2		
BSME R/L35020D4S6			3.5	6.0	3.0	40.5	1.70	14.3	0.2		
BSME R/L40020D2S6			4.0	6.0	3.5	33.9	1.95	8.3	0.2		
BSME R/L40020D3S6			4.0	6.0	3.5	37.9	1.95	12.3	0.2		
BSME R/L40020D4S6			4.0	6.0	3.5	41.9	1.95	16.3	0.2		
BSME R/L45020D2S6			4.5	6.0	4.0	35.0	2.20	9.3	0.2		
BSME R/L45020D3S6			4.5	6.0	4.0	39.5	2.20	13.8	0.2		
BSME R/L45020D4S6			4.5	6.0	4.0	44.0	2.20	18.3	0.2		
BSME R/L50020D2S6			5.0	6.0	4.5	35.8	2.45	10.3	0.2		
BSME R/L50020D3S6			5.0	6.0	4.5	40.8	2.45	15.3	0.2		
BSME R/L50020D4S6			5.0	6.0	4.5	45.8	2.45	20.3	0.2		

■ **Adaptor Sleeve** The BSME Type needs adapter sleeve HBSM6020 (sold separately).

<p>Adaptor sleeve is optional</p>							
Cat. No.	Stock	Dimensions (mm)		Setting Screw	Wrench		
		ϕD_s	L_1				
HBSM6020		6.0	80	BT0506	TH025		

■ **Alignment Jig***

Cat. No.	Stock
AFBSM60	

■ **Newly Developed Clamp Mechanism**

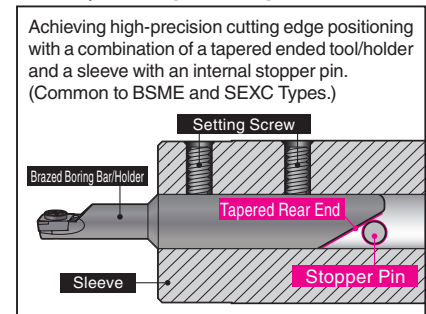

* This jig is used for centering sleeves when setting them into holders.



SUMIBORON

* All items are available 2-3 weeks of purchase

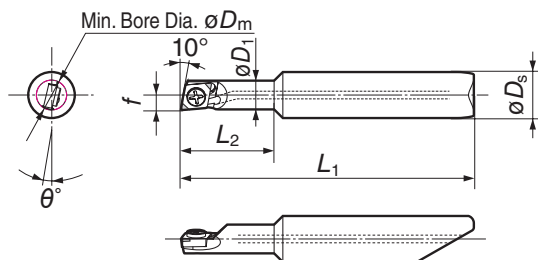
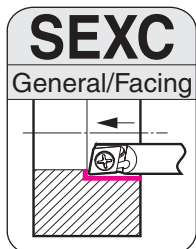

■ Spare Parts

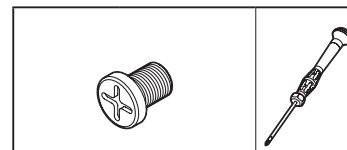

■ Holder

Cat. No.	Stock		Min. Bore Dia. ϕD_m	Dimensions (mm)						Sleeve	Clamp Bolt	Recommended Tightening Torque (N·m)	Wrench
	R	L		ϕD_s	ϕD_1	L_1	f	L_2	r_ϵ				
E06D2-SEXC R/L03-04P			4.0	6.0	3.75	33.75	1.95	8	-13	HBSM6020	MIB1.6-2	0.2	SDBSM
E06D3-SEXC R/L03-04P			4.0	6.0	3.75	37.75	1.95	12	-13				
E06D2-SEXC R/L03-05P			5.0	6.0	4.75	35.25	2.45	10	-12				
E06D3-SEXC R/L03-05P			5.0	6.0	4.75	40.25	2.45	15	-12				
E06D2-SEXC R/L03-06P			6.0	6.0	5.75	36.75	2.95	12	-11				
E06D3-SEXC R/L03-06P			6.0	6.0	5.75	42.75	2.95	18	-11				

The SEXC Type needs adapter sleeve HBSM6020 (sold separately).

■ Insert

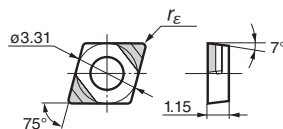

Cat. No.	Stock		Dimensions (mm)
	BN2000	BN7000	
2NU-ECXA 030X02LE			Nose Radius U
			0.2
2NU-ECXA 030X02LF			0.2

LE: Honed Edge, LF: Sharp Edge

■ Adaptor Sleeve

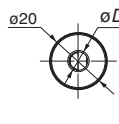

Cat. No.	Stock	Dimensions (mm)		Setting Screw	Wrench
		ϕD_s	L_1		
HBSM6020		6.0	80	BT0506	TH025

Adaptor sleeve is optional

■ Alignment Jig*

Cat. No.	Stock
AFBSM60	

* This jig is used for centering sleeves when setting them into holders.

■ Application Range

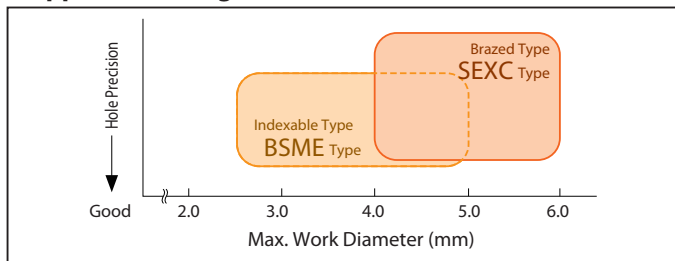

■ Recommended Cutting Conditions

Spindle Speed n	Above 2,000min ⁻¹	May cause chattering or chipping at the cutting edge in low-speed machining.
Depth-of-cut a_p	0.01 to 0.15mm	Excessive cutting depth causes deformation of the tool, which consequently leads to dimensional accuracy deterioration.
Feed Rate f	0.01 to 0.10mm/rev	-

■ Application Example

Hardened Alloy Steel Valve Component **BSME**

The BSME type provides stable machining and a tool life that is over 2 times longer than our competitors' CBN tools.

Tool Type	Output (pcs)
Indexable Type BSME	1,700 pcs
Comp. CBN Tool	600 pcs

Work Material : Hardened Alloy Steel Valve Component (Automotive Component)
 Tool : BSME R5002D2S6 Grade : BN2000
 Cutting Conditions : $v_c=135$ m/min (7,500min⁻¹) $f=0.02$ mm/rev $a_p=0.10$ mm Dry

Bearing Steel Small Automotive Component **SEXC**

The SEXC type provides drastically reduced tool costs and a tool life that is 1.5 times longer than our competitors' brazed CBN tools.

Tool Type	Output (pcs)
Brazed Type SEXC	1,500 pcs
Comp. Brazed CBN Tool	1,000 pcs

Work Material : Bearing Steel Small Automotive Component (60HRC)
 Holder : E06D2-SEXC R/L03-04P Insert : 2NU-ECXA 030X02LF (BN2000)
 Cutting Conditions : $v_c=50$ m/min (4,000min⁻¹) $f=0.02$ mm/rev $a_p=0.02$ mm Wet



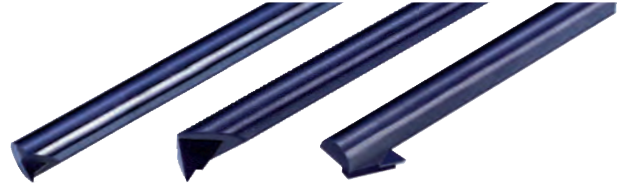

SUMIDIA

DABB-C
Stop, Through and Back Chamfer

■ Brazed Bite

Cat. No.	Stock	Min. Bore Dia.	Dimensions (mm)				Applicable Sleeve
	DA2200	øD _m	øD _s	h	L ₁	r _E	
DABB 025CR	★	3.0	2.5	2.2	60	0.1	HBB 2516
DABB 035CR	★	4.0	3.5	3.2	60	0.1	HBB 3516
DABB 045CR	★	5.0	4.5	4.1	80	0.1	HBB 4516
DABB 060CR	★	7.0	6.0	5.2	80	0.1	HBB 616

DABB-N
Stop, Through and Necking

■ Brazed Bite

Cat. No.	Stock	Min. Bore Dia.	Dimensions (mm)				Applicable Sleeve
	DA2200	øD _m	øD _s	h	L ₁	r _E	
DABB 025NR	★	3.0	2.5	2.2	60	0.1	HBB 2516
DABB 035NR	★	4.0	3.5	3.2	60	0.1	HBB 3516
DABB 045NR	★	5.0	4.5	4.1	80	0.1	HBB 4516
DABB 060NR	★	7.0	6.0	5.2	80	0.1	HBB 616

■ Spare Parts



(For Hexagonal Holes)

■ Adaptor Sleeve

	Cat. No.	Stock	øD _s (mm)	Setting Screw	Wrench
	HBX2516	★	2.5	BT 0404	TH 020
HBX3516	★	3.5			
HBX4516	★	4.5			
HBX6016	★	6.0			

* This jig is used for centering sleeves when setting them into holders.





SUMITOMO

CARBIDE - CBN - DIAMOND

1-800-950-5202

www.sumicarbide.com

THREADING, GROOVING, & CUT-OFF HOLDERS

Pages 277-314



Threading,
Grooving,
&
Cut-Off Holders

THREADING, GROOVING, & CUT-OFF

PAGES

GND Series.....	278-297
SumiTurn B-Groove.....	298-299
SumiNotch Grooving Toolholders & Bars.....	300-302
CBN Grooving Toolholders.....	303-304
Threading Toolholders.....	305-307
SumiCut-Off™ Toolholders.....	308-314

GROOVING TOOLHOLDERS

GND SERIES

Grooving Toolholders

GND Series - Product Range

High Rigidity Body

The GND series is designed for grooving and features a single-piece construction made of special steel. This design reduces chatter and also delivers steady performance for turning, profiling, and facing.

Wide Range of Chipbreakers

The GND lineup features 8 types of chipbreakers for various machining applications. Offers consistent chip control under various conditions.



Grooving Tool Holders GND Type



Model	Shank Size Range	Seat Size Availability	Application	Page #	Model	Shank Size Range	Seat Size Availability	Application	Page #
GNDM Straight Type	Inch □ .750" x .750" □ 1.00" x 1.00" □ 1.25" x 1.25" Metric □ 16 x 16mm □ 20 x 20mm □ 25 x 25mm □ 32 x 25mm □ 32 x 32mm	1.25 1.5 2.0 3.0 4.0 5.0 6.0 7.0 8.0	Grooving, Turning, Profiling	Inch: pg. 283 Metric: pg. 287	GNDI Straight Type	Inch □ 1.00" □ 1.25" □ 1.50" Metric □ 25mm □ 32mm □ 40mm	1.25 1.5 2.0 3.0 4.0 5.0 6.0 7.0 8.0	Grooving, Turning, Profiling	pg. 291
GNDMS L Type	Inch □ .750" x .750" □ 1.00" x 1.00" Metric □ 20 x 20mm □ 25 x 25mm	1.25 1.5 2.0 3.0 4.0 5.0 6.0 7.0 8.0	Grooving, Turning, Profiling	Inch: pg. 283 Metric: pg. 287	GDNF Straight Type	Inch □ .750" x .750" □ 1.00" x 1.00" Metric □ 20 x 20mm □ 25 x 25mm	1.25 1.5 2.0 3.0 4.0 5.0 6.0 7.0 8.0	Grooving, Turning, Profiling	Inch: pg. 285 Metric: pg. 290
GNDL Straight Type	Inch □ .750" x .750" □ 1.00" x 1.00" □ 1.25" x 1.25" Metric □ 10 x 10mm □ 12 x 12mm □ 16 x 16mm □ 20 x 20mm □ 25 x 25mm □ 32 x 25mm □ 32 x 32mm	1.25 1.5 2.0 3.0 4.0 5.0 6.0 7.0 8.0	Grooving, Cut-Off	Inch: pg. 284 Metric: pg. 288	GNDFS L Type	Metric □ 25 x 25mm □ 32 x 32mm	1.25 1.5 2.0 3.0 4.0 5.0 6.0 7.0 8.0	Grooving, Turning, Profiling	pg. 291
GNDLS L Type	Inch □ .750" x .750" □ 1.00" x 1.00" Metric □ 20 x 20mm □ 25 x 25mm	1.25 1.5 2.0 3.0 4.0 5.0 6.0 7.0 8.0	Grooving, Cut-Off	Inch: pg. 284 Metric: pg. 288					



Threading, Grooving, & Cut-Off Holders

Eliminates Vibration

High rigid design reduces vibration by as much as 30% over conventional types

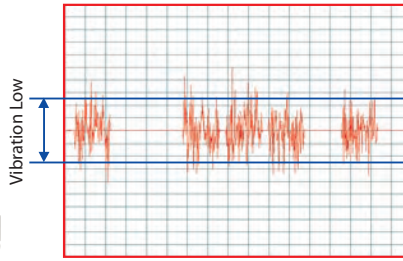
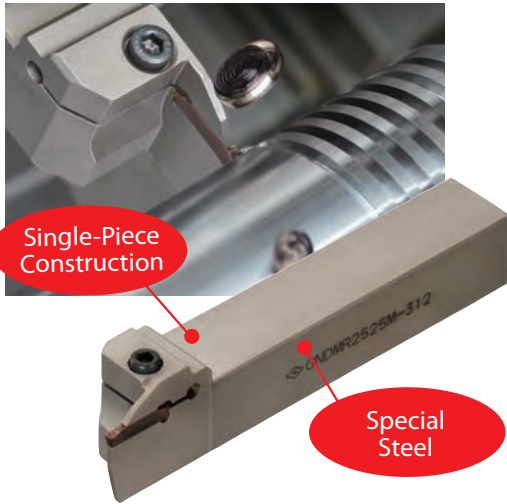

GND
GND Type

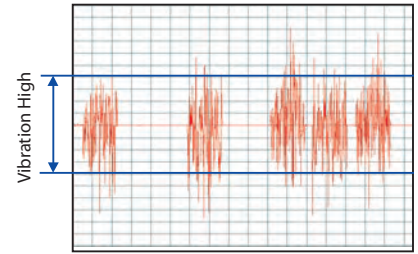

Conventional Tool (Unit Type)

4115 Steel Part Material	GNDL R2525M-220 Holder	GCM N2002-GG Insert
$v_c=328$ SFM, $f=0.004$ IPR, $a_p=0.78"$, Wet Cutting Conditions		

Excellent Chip Control

Special chipbreakers for various machining applications (grooving, turning)

Grooving



GND Type (GG Type Chipbreaker)

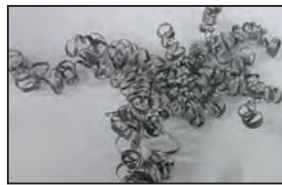

Conventional Tool

4115 Steel Part Material	GNDL R2525M-320 Holder	GCM N3002-GG Insert
$v_c=328$ SFM, $f=0.006$ IPR, $a_p=0.472"$, Wet Cutting Conditions		

Turning

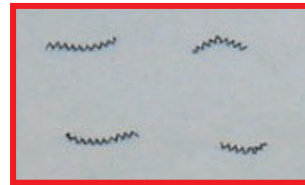

GND Type (ML Type Chipbreaker)



Conventional Tool

4115 Steel Part Material	GNDM R2525M-312 Holder	GCM N3002-ML Insert
$v_c=328$ SFM, $f=0.004$ IPR, $a_p=0.020"$ Wet Cutting Conditions		



GND Type (RG Type Chipbreaker)



Conventional Tool

4115 Steel Part Material	GNDM R2525M-312 Holder	GCM N3015-RG Insert
$v_c=328$ SFM, $f=0.005$ IPR, $a_p=0.039"$, Wet Cutting Conditions		



GND Type (RG Type Chipbreaker)



Conventional Tool

4115 Steel Part Material	GNDM R2525M-312 Holder	GCM N3015-RG Insert
$v_c=328$ SFM, $f=0.006$ IPR, $a_p=0.004"$, Wet Cutting Conditions		

Improved Precision

Our precision sintering technology delivers $\pm 0.03\text{mm}$ accuracy for all grooving widths (from 2.0 to 6.0 mm).



GND Type Holder Selection Guide

External Grooving

Face Grooving

Internal Grooving

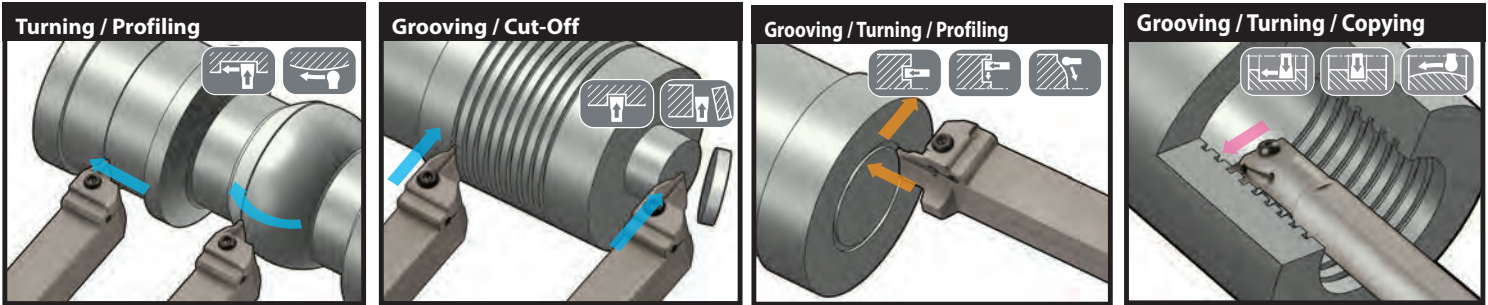

GNDM Type / GNDMS Type

Perfect for turning and profiling. Can also be used for grooving.

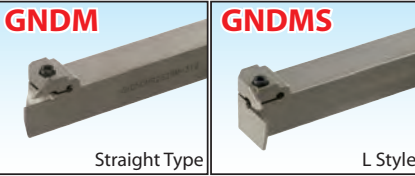

GNDL Type / GNDLS Type

Perfect for grooving and cut-off applications. Handles deep grooving with ease.

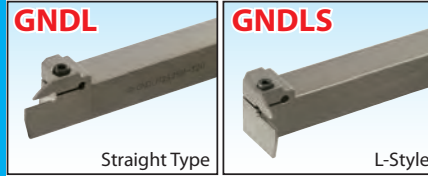

GNDF Type / GNDFS Type

For facing work.

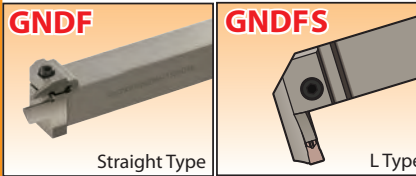

GNDI Type

for internal grooving.



GND Type Chipbreaker Selection

Grooving/Turning				Grooving/Cut-Off				Copying
General Purpose Type	Low Feed Type	General Purpose Type	Low Feed Type	Low Cutting Force Type	Low Cutting Force Type	Cut-Off Type	General Purpose Type	
Standard insert for turning	For low-feed chip management	First choice for grooving	For low-feed chip management	Applicable to ultra-thin grooving	For Non-ferrous Materials	Ideal for cut-off applications	Perfect for copying	
MG Type	ML Type	GG Type	GL Type	GF Type	GA Type <i>New</i>	CG Type	RG Type	
Cross Section of Cutting Edge	Cross Section of Cutting Edge	Cross Section of Cutting Edge	Cross Section of Cutting Edge	Cross Section of Cutting Edge	Cross Section of Cutting Edge	Cross Section of Cutting Edge	Cross Section of Cutting Edge	
0.10 15°	0.05 20°	0.10 20°	0.10 20°	30°	20°	25°	0.05 25°	

Recommended Cutting Conditions

Part Material	P				M			K			S		N			
	Carbon Steel/ Alloy Steel				Stainless Steel			Gray Cast Iron			Ductile Cast Iron		Exotic Alloy	Non-ferrous		
Grade	AC830P	AC520U	AC530U	T2500A (Cermet)	AC830P	AC520U	AC530U	AC425K	AC520U	AC530U	AC425K	AC520U	AC530U	H10		
Speed (SFM)	260-650	260-650	165-650	350-750	230-500	230-500	165-500	260-650	200-650	165-650	400-600	200-500	165-500	65-260	65-200	500-1000

Grooving & Cutoff	Breaker	MG	ML	GG	GL	RG	CG	GA
		Feed (ipr)	Feed (ipr)	Feed (ipr)	Feed (ipr)	Feed (ipr)	Feed (ipr)	Feed (ipr)
	Seat Size	2	-	-	.002-.010	.001-.006	-	.002-.008
3	.003-.008	.001-.006	.004-.012	.002-.008	.003-.006	.003-.010	.004-.012	
4	.004-.010	.002-.008	.006-.014	.003-.009	.004-.008	.004-.012	.006-.014	
5	.005-.012	.003-.010	.008-.016	.004-.010	.006-.010	-	.008-.016	
6	.006-.014	.004-.012	.008-.018	.005-.012	.008-.012	-	.008-.018	
7	.007-.016	.005-.014	.008-.020	.006-.014	.010-.014	-	-	
8	.008-.018	.006-.016	.008-.022	.007-.016	.014-.016	-	-	

Turning	Breaker	MG	ML	RG			
		Feed (ipr)	Depth (in)	Feed (ipr)	Depth (in)	Feed (ipr)	Depth (in)
	Seat Size	3	.003-.010	.016-.06	.002-.007	.012-.060	.004-.016
4	.004-.012	.020-.08	.002-.008	.016-.080	.006-.018	.024-.064	
5	.005-.014	.030-.10	.003-.010	.020-.100	.008-.020	.030-.080	
6	.006-.016	.040-.12	.004-.012	.020-.120	.012-.024	.040-.090	
7	.007-.016	.048-.014	.005-.014	.028-.014	.014-.026	.048-.098	
8	.008-.018	.060-.016	.006-.016	.028-.016	.014-.028	.060-.120	

*For difficult to machine and harder materials, please adjust speeds and feeds accordingly



Grooving Toolholders

GND Series - Chipbreaker Selection

GROOVING TOOLHOLDERS

GND SERIES

Chipbreaker Selection Guide

Groov. Width (mm)	Recommended Cutting Conditions		Nose Radius (mm)	Inserts
	Grooving	Turning		
1.25	Chipbreaker GF 		.008	GCM N12505 GF
1.5	Chipbreaker GF 		.008	GCM N150005 GF
2.0	Chipbreaker MG ML GG GL GF RG CG GA 		.008	GCM N2002 GG GCM N2002 GL GCM N2002 GF GCM R/L2002 CG05
			.016	GCM N3002 ML GCM N3002 GG GCM N3002 GL GCM N3002 GF GCM R/L3002 CG05
3.0	Chipbreaker MG ML GG GL GF RG CG GA 		.008	GCM N3002 ML GCM N3002 GG GCM N3002 GL GCM N3002 GF GCM R/L3002 CG05
			.016	GCM N3004 MG GCM N3004 GG
			.060	GCM N3015 RG
4.0	Chipbreaker MG ML GG GL GF RG CG GA 		.008	GCM N4002 GG GCM N4002 GL GCM N4002 GF GCM R/L4002 CG05
			.016	GCM N4004 ML GCM N4004 GG
			.032	GGCM N 4008 MG
			.078	GCM N4020 RG
5.0	Chipbreaker MG ML GG GL GF RG GA 		.008	GCM N5002 GG GCM N5002 GL GCM N5002 GF
			.016	GCM N5004 ML GCM N5004 GG
			.032	GCM N5008 MG
			.098	GCM N5025 RG
6.0	Chipbreaker MG ML GG GL GF RG GA 		.008	GCM N6002 GG GCM N6002 GL GCM N6002 GF
			.016	GCM N6004 ML GCM N6004 GG
			.032	GCM N6008 MG
			.118	GCM N6030 RG
7.0	Chipbreaker MG ML GG GL RG 		.016	GCM N7004 ML GCM N7004 GG GCM N7004 GL
			.032	GCM N7008 MG
			.134	GCM N7035 RG
8.0	Chipbreaker MG ML GG GL RG 		.016	GCM N8004 ML GCM N8004 GG GCM N8004 GL
			.032	GCM N8008 MG
			.160	GCM N8040 RG

Threading, Grooving, & Cut-Off Holders



Nomenclature for OD Groover GND Series

GND M R/L 16 3 M -075

#1-3 #4 #5 #6 #7 #8 #9

#1-3 Series Name	#4 Application	#5 Handedness	#6 Shank Size*16	#7 Seat Size	#8 Overall Length	#9 Max Groove Depth*100
#1 Groove #2 New #3 Depth	M: Multi-function L: Deep Groove MS: 90° Multi LS: 90° Deep	R: Right Handed L: Left Handed	12: 0.750 x 0.750" 16: 1.000 x 1.000" 20: 1.250 x 1.250"	2 3 4 5 6 7 8	K: 5.0" M: 6.0" P: 7.0"	050: 0.50" 070: 0.70" 075: 0.75" 090: 0.90" 100: 1.00"

Nomenclature for Face Grooving Holders

GND F R/L 16 3 M -075 -035

#1-3 #4 #5 #6 #7 #8 #9 #10

#1-3 Series Name	#4 Application	#5 Handedness	#6 Shank Size*16	#7 Seat Size	#8 Overall Length	#9 Max Groove Depth*100
#1 Groove #2 New #3 Depth	F: Face Groover FS: 90° Face	R: Right Handed L: Left Handed	12: 0.750 x 0.750" 16: 1.000 x 1.000" 20: 1.250 x 1.250"	2 3 4 5 6 8	K: 5.0" M: 6.0" P: 7.0"	050: 0.50" 070: 0.70" 075: 0.75" 090: 0.90"

#10 Min.Part Diam. mm (Inch)	#10 Min.Part Diam. mm (Inch) (cont.)
035: 35mm (1.378")	090: 90mm (3.543")
040: 40mm (1.575")	100: 100mm (3.937")
045: 45mm (1.772")	125: 125mm (4.921")
050: 50mm (1.969")	140: 140mm (5.512")
065: 65mm (2.559")	180: 180mm (7.087")
085: 85mm (3.346")	280: 280mm (11.024")

Insert Nomenclature

GCM N 3 125 R0.5 -GG -AC530U

#1-3 #4 #5 #6 #7 #8 #9

#1-3 Series Name	#4 Handedness	#5 Seat Size	#6 Groove Width*100	#7 Corner Radius in 64ths	#8 Chipbreaker
#1 G: Grooving Insert #2 C: 7° Relief Angle #3 M: Molded Tolerance	R: Right Handed L: Left Handed N: Neutral	2 3 4 5 6 7 8	094: 0.094" 125: 0.125" 187: 0.187" 250: 0.250"	R0.5: 0.5/64 = 0.0078" R1.0: 1/64 = 0.0156" R2.0: 2/64 = 0.0312"	GG: Std. Feed Deep Groove GL: Low Feed Deep Groove MG: Std. Feed Traverse ML: Low Feed Traverse RG: Full Radius Profiling GF: Low Cutting Force GA: Non-ferrous grooving

*Note: Items with the RG chipbreaker have a radius equal to 1/2 the width (Ex: GCMN3125-RG = 0.0625")

#9: Grade
AC520U: Universal Grade For most materials
AC530U: Universal Grade For most materials
AC830P: Tough CVD Grade For steels
AC425K: CVD Grade For Cast and Ductile Irons
T2500A: finishing of steels and stainless steels
H10: for non-ferrous materials



Threading, Grooving, & Cut-Off Holders

External Multi-Purpose (Grooving / Turning / Profiling)

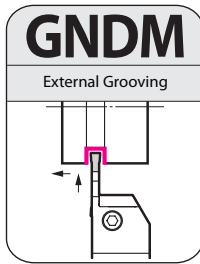

Use for multi-purpose or profiling insert for turning (widening).

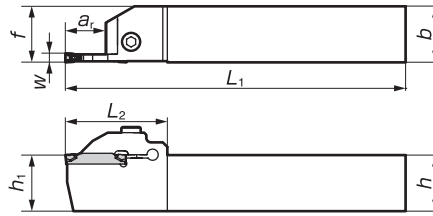

Above figures show right hand tools

Catalog Number	Dimensions (in)						Groove Width W (inch)	Max. Groove depth ar (inch)	Seat Size	Cap Screw	Wrench
	h	b	L1	f	h1	L2					
GNDM L/R 122K-050	.750	.750	5.000	.750	.750	1.441	.094	.500	2	BX0520	LH040
GNDM L/R 123K-050	.750	.750	5.000	.750	.750	1.441	.125	.500	3		
GNDM L/R 124K-070	.750	.750	5.000	.750	.750	1.772	.157	.700	4		
GNDM L/R 125K-070	.750	.750	5.000	.750	.750	1.772	.1875	.700	5		
GNDM L/R 126K-070	.750	.750	5.000	.750	.750	1.772	.250	.700	6		
GNDM L/R 162K-050	1.000	1.000	6.000	1.000	1.000	1.441	.094	.500	2		
GNDM L/R 163M-050	1.000	1.000	6.000	1.000	1.000	1.441	.125	.500	3		
GNDM L/R 164M-070	1.000	1.000	6.000	1.000	1.000	1.772	.157	.700	4		
GNDM L/R 165M-070	1.000	1.000	6.000	1.000	1.000	1.772	.1875	.700	5		
GNDM L/R 166M-070	1.000	1.000	6.000	1.000	1.000	1.772	.250	.700	6		
GNDM L/R 203P-050	1.250	1.250	6.750	1.250	1.250	1.441	.125	.500	3		
GNDM L/R 204P-070	1.250	1.250	6.750	1.250	1.250	1.772	.157	.700	4		
GNDM L/R 205P-070	1.250	1.250	6.750	1.250	1.250	1.772	.1875	.700	5		
GNDM L/R 206P-070	1.250	1.250	6.750	1.250	1.250	1.772	.250	.700	6		
GNDM L/R 207P-070	1.250	1.250	6.750	1.250	1.250	2.000	.275	.700	7		
GNDM L/R 208P-070	1.250	1.250	6.750	1.250	1.250	2.000	.315	.700	8		

Please see page 296 for applicable inserts

External L-Styled (Side Cut) Multi-Purpose (Grooving / Turning / Profiling)

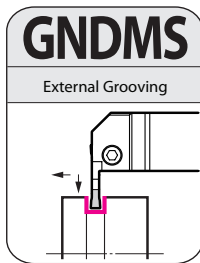

Use for multi-purpose or profiling insert for turning (widening).

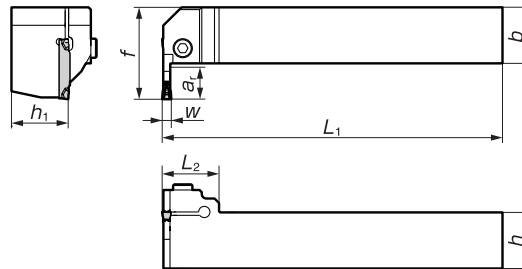

Above figures show right hand tools

Catalog Number	Dimensions (in)						Groove Width W (inch)	Max. Groove depth ar (inch)	Seat Size	Cap Screw	Wrench
	h	b	L1	f	h1	L2					
GNDMS L/R 123K-040	.750	.750	5.000	1.222	.750	1.000	.125	.4000	3	BX0520	LH040
GNDMS L/R 124K-050	.750	.750	5.000	1.300	.750	1.000	.157	.5000	4		
GNDMS L/R 125K-050	.750	.750	5.000	1.300	.750	1.000	.1875	.5000	5		
GNDMS L/R 163M-050	1.000	1.000	6.000	1.551	1.000	1.000	.125	.5000	3		
GNDMS L/R 164M-055	1.000	1.000	6.000	1.630	1.000	1.000	.157	.5500	4		
GNDMS L/R 165M-055	1.000	1.000	6.000	1.630	1.000	1.000	.1875	.5500	5		
GNDMS L/R 166M-055	1.000	1.000	6.000	1.630	1.000	1.000	.250	.5500	6		

Please see page 296 for applicable inserts



External Deep Grooving / Cut-Off

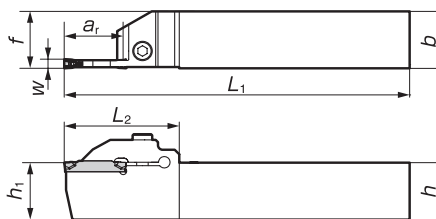
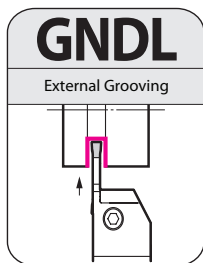

Above figures show right hand tools

Catalog Number	Dimensions (in)						Groove Width W (inch)	Max. Groove depth ar (inch)	Seat Size	Cap Screw	Wrench
	h	b	L1	f	h1	L2					
GNDL L/R 122K-075	.750	.750	5.000	.750	.750	1.752	.094	.750	2	BX0520	LH040
GNDL L/R 123K-075	.750	.750	5.000	.750	.750	1.752	.125	.750	3		
GNDL L/R 124K-100	.750	.750	5.000	.750	.750	1.969	.157	1.000	4		
GNDL L/R 125K-100	.750	.750	5.000	.750	.750	1.969	.1875	1.000	5		
GNDL L/R 126K-100	.750	.750	5.001	.750	.750	1.969	.250	1.000	6		
GNDL L/R 162M-075	1.000	1.000	6.000	1.000	1.000	1.752	.094	.750	2		
GNDL L/R 163M-075	1.000	1.000	6.000	1.000	1.000	1.752	.125	.750	3		
GNDL L/R 164M-100	1.000	1.000	6.000	1.000	1.000	1.969	.157	1.000	4		
GNDL L/R 165M-100	1.000	1.000	6.000	1.000	1.000	1.969	.187	1.000	5		
GNDL L/R 166M-100	1.000	1.000	6.000	1.000	1.000	1.969	.250	1.000	6		
GNDL L/R 203P-090	1.250	1.250	6.750	1.250	1.250	1.752	.125	0.900	3	BX0620	LH050
GNDL L/R 204P-100	1.250	1.250	6.750	1.250	1.250	2.000	.157	1.000	4		
GNDL L/R 205P-100	1.250	1.250	6.750	1.250	1.250	2.000	.1875	1.000	5		
GNDL L/R 206P-100	1.250	1.250	6.750	1.250	1.250	2.000	.250	1.000	6		
GNDL L/R 207P-100	1.250	1.250	6.750	1.250	1.250	2.000	.275	1.000	7		
GNDL L/R 208P-100	1.250	1.250	6.750	1.250	1.250	2.000	.315	1.000	8		

Please see page 296 for applicable inserts

External L-Style (Side Cut) Grooving

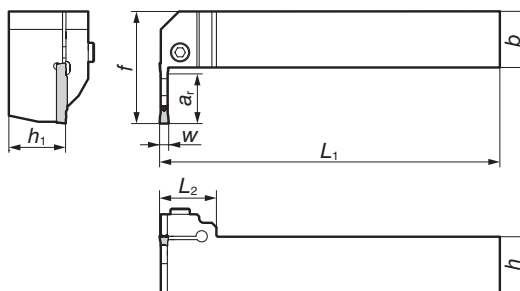
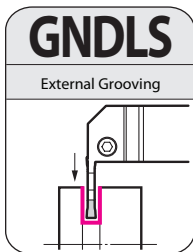

Above figures show right hand tools

Catalog Number	Dimensions (in)						Groove Width W (inch)	Max. Groove depth ar (inch)	Seat Size	Cap Screw	Wrench
	h	b	L1	f	h1	L2					
GNDLS L/R 122K-060	.750	.750	5.000	1.459	.750	1.000	.094	.600	2	BX0520	LH040
GNDLS L/R 123K-060	.750	.750	5.000	1.459	.750	1.000	.125	.600	3		
GNDLS L/R 124K-070	.750	.750	6.000	1.787	.750	1.000	.157	.700	4		
GNDLS L/R 162M-070	1.000	1.000	6.000	1.787	1.000	1.000	.094	.700	2		
GNDLS L/R 163M-070	1.000	1.000	6.000	1.787	1.000	1.000	.125	.700	3		
GNDLS L/R 164M-090	1.000	1.000	6.000	1.984	1.000	1.000	.157	.900	4		
GNDLS L/R 165M-090	1.000	1.000	6.000	1.984	1.000	1.000	.1875	.900	5		
GNDLS L/R 166M-090	1.000	1.000	6.000	1.984	1.000	1.000	.250	.900	6		

Please see page 296 for applicable inserts



Threading, Grooving, & Cut-Off Holders

Face Grooving

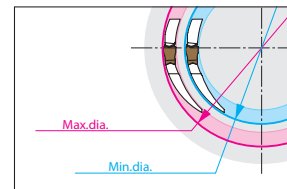
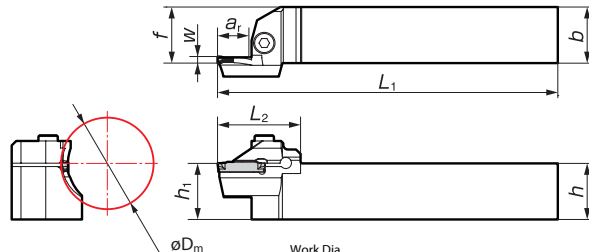
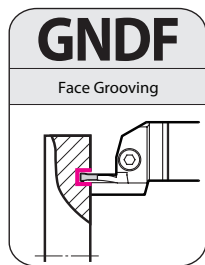

Work diameters in stock table indicate external diameter of face groove.

Above figures show right hand tools

Catalog Number	Dimensions (in)						Work Dia. ΦD_m		Grooving width	Max. Grooving Depth ar (inch)	Seat Size	Cap Screw	Wrench
	h	b	L1	f	h1	L2	Min.	Max.					
GNDF L/R 123K-050-035	.750	.750	5.000	.750	.750	1.402	1.378	1.772	.125	.500	3	BX0520	LH040
GNDF L/R 123K-050-040	.750	.750	5.000	.750	.750	1.402	1.575	2.165	.125	.500	3		
GNDF L/R 123K-070-050	.750	.750	5.000	.750	.750	1.638	1.969	2.756	.125	.700	3		
GNDF L/R 123K-070-065	.750	.750	5.000	.750	.750	1.638	2.559	3.397	.125	.700	3		
GNDF L/R 123K-070-090	.750	.750	5.000	.750	.750	1.638	3.543	5.906	.125	.700	3		
GNDF L/R 123K-070-140	.750	.750	5.000	.750	.750	1.638	5.512	7.874	.125	.700	3		
GNDF L/R 123K-070-180	.750	.750	5.000	.750	.750	1.638	7.087	11.811	.125	.700	3		
GNDF L/R 124K-070-040	.750	.750	5.000	.750	.750	1.638	1.575	2.165	.157	.700	4		
GNDF L/R 124K-090-050	.750	.750	5.000	.750	.750	1.835	1.969	2.756	.157	.900	4		
GNDF L/R 124K-090-065	.750	.750	5.000	.750	.750	1.835	2.559	3.543	.157	.900	4		
GNDF L/R 124K-090-085	.750	.750	5.000	.750	.750	1.835	3.346	5.118	.157	.900	4		
GNDF L/R 124K-090-125	.750	.750	5.000	.750	.750	1.835	4.921	7.874	.157	.900	4		
GNDF L/R 124K-090-180	.750	.750	5.000	.750	.750	1.835	7.087	11.811	.157	.900	4		
GNDF L/R 124K-090-280	.750	.750	5.000	.750	.750	1.835	11.024	39.370	.157	.900	4		
GNDF L/R 125K-090-050	.750	.750	5.000	.750	.750	1.835	1.969	2.756	.1875	.900	5		
GNDF L/R 125K-090-065	.750	.750	5.000	.750	.750	1.835	2.559	3.543	.1875	.900	5		
GNDF L/R 125K-090-085	.750	.750	5.000	.750	.750	1.835	3.346	5.118	.1875	.900	5		
GNDF L/R 125K-090-125	.750	.750	5.000	.750	.750	1.835	4.921	7.874	.1875	.900	5		
GNDF L/R 125K-090-180	.750	.750	5.000	.750	.750	1.835	7.087	11.811	.1875	.900	5		
GNDF L/R 125K-090-280	.750	.750	5.000	.750	.750	1.835	11.024	39.370	.1875	.900	5		
GNDF L/R 126K-090-050	.750	.750	5.000	.750	.750	1.835	1.969	2.953	.250	.900	6		
GNDF L/R 126K-090-070	.750	.750	5.000	.750	.750	1.835	2.756	4.331	.250	.900	6		
GNDF L/R 126K-090-100	.750	.750	5.000	.750	.750	1.835	3.397	7.874	.250	.900	6		
GNDF L/R 126K-090-180	.750	.750	5.000	.750	.750	1.835	7.087	11.811	.250	.900	6		
GNDF L/R 126K-090-280	.750	.750	5.000	.750	.750	1.835	11.024	39.370	.250	.900	6		
GNDF L/R 163M-050-035	1.000	1.000	6.000	1.000	1.000	1.402	1.378	1.772	.125	.500	3	BX0520	LH040
GNDF L/R 163M-050-040	1.000	1.000	6.000	1.000	1.000	1.402	1.575	2.165	.125	.500	3		
GNDF L/R 163M-070-050	1.000	1.000	6.000	1.000	1.000	1.638	1.969	2.756	.125	.700	3		
GNDF L/R 163M-070-065	1.000	1.000	6.000	1.000	1.000	1.638	2.559	3.397	.125	.700	3		
GNDF L/R 163M-070-090	1.000	1.000	6.000	1.000	1.000	1.638	3.543	5.906	.125	.700	3		
GNDF L/R 163M-070-140	1.000	1.000	6.000	1.000	1.000	1.638	5.512	7.874	.125	.700	3		
GNDF L/R 163M-070-180	1.000	1.000	6.000	1.000	1.000	1.638	7.087	11.811	.125	.700	3		
GNDF L/R 164M-070-040	1.000	1.000	5.000	.750	.750	1.638	1.575	2.165	.157	.700	4		
GNDF L/R 164M-090-050	1.000	1.000	5.000	.750	.750	1.835	1.969	2.756	.157	.900	4		
GNDF L/R 164M-090-065	1.000	1.000	5.000	.750	.750	1.835	2.559	3.543	.157	.900	4		
GNDF L/R 164M-090-085	1.000	1.000	5.000	.750	.750	1.835	3.346	5.118	.157	.900	4		
GNDF L/R 164M-090-125	1.000	1.000	5.000	.750	.750	1.835	4.921	7.874	.157	.900	4		
GNDF L/R 164M-090-180	1.000	1.000	5.000	.750	.750	1.835	7.087	11.811	.157	.900	4		
GNDF L/R 164M-090-280	1.000	1.000	5.000	.750	.750	1.835	11.024	39.370	.157	.900	4		
GNDF L/R 165M-090-050	1.000	1.000	6.000	1.000	1.000	1.835	1.969	2.756	.1875	.900	5		
GNDF L/R 165M-090-065	1.000	1.000	6.000	1.000	1.000	1.835	2.559	3.543	.1875	.900	5		
GNDF L/R 165M-090-085	1.000	1.000	6.000	1.000	1.000	1.835	3.346	5.118	.1875	.900	5		
GNDF L/R 165M-090-125	1.000	1.000	6.000	1.000	1.000	1.835	4.921	7.874	.1875	.900	5		
GNDF L/R 165M-090-180	1.000	1.000	6.000	1.000	1.000	1.835	7.087	11.811	.1875	.900	5		
GNDF L/R 165M-090-280	1.000	1.000	6.000	1.000	1.000	1.835	11.024	39.370	.1875	.900	5		
GNDF L/R 166M-090-050	1.000	1.000	6.000	1.000	1.000	1.835	1.969	2.953	.250	.900	6		
GNDF L/R 166M-090-070	1.000	1.000	6.000	1.000	1.000	1.835	2.756	4.331	.250	.900	6		
GNDF L/R 166M-090-100	1.000	1.000	6.000	1.000	1.000	1.835	3.937	7.874	.250	.900	6		
GNDF L/R 166M-090-180	1.000	1.000	6.000	1.000	1.000	1.835	7.087	11.811	.250	.900	6		
GNDF L/R 166M-090-280	1.000	1.000	6.000	1.000	1.000	1.835	11.024	39.370	.250	.900	6		

Please see page 296 for applicable inserts



Nomenclature for OD Groover GND Series (METRIC)

GND M R/L 2525 M - 3 12

#1-3 #4 #5 #6 #7 #8 #9

#1-3 Series Name	#4 Application	#5 Handedness	#6 Shank Size (mm)	#7 Overall Length	#8 Seat Size	#9 Max Groove Depth (mm)
#1 Groove #2 New #3 Depth	M: Multi-function L: Deep Groove MS: 90° Multi LS: 90° Deep S: Shallow Groove	R: Right Handed L: Left Handed	1010: 10 x 10 mm 1212: 12 x 12 mm 1616: 16 x 16 mm 2020: 20 x 20 mm 2525: 25 x 25 mm 3232: 32 x 32 mm	JX: 120 mm K: 125 mm M: 150 mm P: 170 mm	1.25 1.5 2 3 4 5 6 7 8	10 12 12.5 14 16 18 20 23 25

Nomenclature for Face Grooving Holders

GND F R/L 2525 M - 3 18 - 090

#1-3 #4 #5 #6 #7 #8 #9 #10

#1-3 Series Name	#4 Application	#5 Handedness	#6 Shank Size (mm)	#7 Overall Length	#8 Seat Size	#9 Max Groove Depth (mm)
#1 Groove #2 New #3 Depth	F: Face Groover FS: 90° Face	R: Right Handed L: Left Handed	2020: 20 x 20 mm 2525: 25 x 25 mm 3232: 32 x 32 mm	K: 125 mm M: 150 mm P: 170 mm	2 3 4 5 6 8	12 18 23

#10 Min.Part Diam. mm (Inch)	#10 Min.Part Diam. mm (Inch) (cont.)
035: 35mm (1.378")	090: 90mm (3.543")
040: 40mm (1.575")	100: 100mm (3.937")
045: 45mm (1.772")	125: 125mm (4.921")
050: 50mm (1.969")	140: 140mm (5.512")
065: 65mm (2.559")	180: 180mm (7.087")
085: 85mm (3.346")	280: 280mm (11.024")

Insert Nomenclature (METRIC)

GCM N 30 02 -GG -AC530U

#1-3 #4 #5 #6 #7 #8

#1-3 Series Name	#4 Handedness	#5 Seat Size & Groove Width	#6 Corner Radius *10	#7 Chipbreaker	#8: Grade																								
#1 G: Grooving Insert #2 C: 7° Relief Angle #3 M: Molded Tolerance	R: Right Handed L: Left Handed N: Neutral	<table border="1"> <thead> <tr> <th>#</th> <th>Seat</th> <th>Groove Width</th> </tr> </thead> <tbody> <tr><td>20</td><td>2</td><td>2.0 mm</td></tr> <tr><td>30</td><td>3</td><td>3.0 mm</td></tr> <tr><td>40</td><td>4</td><td>4.0 mm</td></tr> <tr><td>50</td><td>5</td><td>5.0 mm</td></tr> <tr><td>60</td><td>6</td><td>6.0 mm</td></tr> <tr><td>70</td><td>7</td><td>7.0 mm</td></tr> <tr><td>80</td><td>8</td><td>8.0 mm</td></tr> </tbody> </table>	#	Seat	Groove Width	20	2	2.0 mm	30	3	3.0 mm	40	4	4.0 mm	50	5	5.0 mm	60	6	6.0 mm	70	7	7.0 mm	80	8	8.0 mm	02 =0.2mm 04 =0.4mm 08 =0.8mm	GG: Std. Feed Deep Groove GL: Low Feed Deep Groove MG: Std. Feed Traverse ML: Low Feed Traverse RG: Full Radius Profiling GF: Low Cutting Force GA: Non-ferrous Material	AC520U: Universal Grade For most materials AC530U: Universal Grade For most materials AC830P: Tough CVD Grade For steels AC425K: CVD Grade For Cast and Ductile Irons T2500A: finishing of steels and stainless steels H10: for non-ferrous materials
#	Seat	Groove Width																											
20	2	2.0 mm																											
30	3	3.0 mm																											
40	4	4.0 mm																											
50	5	5.0 mm																											
60	6	6.0 mm																											
70	7	7.0 mm																											
80	8	8.0 mm																											



Threading, Grooving, & Cut-Off Holders

External Multi-purpose Type (Grooving, Turning, and Copying)

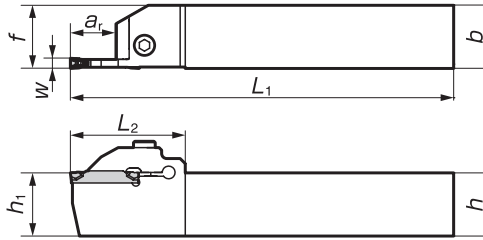
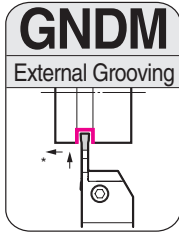

Above figures show right hand tools

* Use the multi-purpose copying insert for turning (wide grooves).

■ Holders

■ Spare Parts

Catalog Number	Dimensions (mm)						Groove Width W(mm)	Max. Groove Depth a _r (mm)	Seat Size	Cap Screw	Recommended Tightening Torque (N-m)	Wrench
	h	b	L ₁	f	h ₁	L ₂						
GNDM R/L1616JX-1.510	16	16	120	16	16	26.0	1.5	10	1.5	BX0515	5.0	LH040
GNDM R/L1616JX-212	16	16	120	16	16	30.0	2.0	12	2			
GNDM R/L1616JX-312	16	16	120	16	16	30.0	3.0	12	3			
GNDM R/L2020K-312	20	20	125	20	20	36.6	3.0	12	3			
GNDM R/L2020K-418	20	20	125	20	20	45.0	4.0	18	4			
GNDM R/L2020K-518	20	20	125	20	20	45.0	5.0	18	5			
GNDM R/L2020K-618	20	20	125	20	20	45.0	6.0	18	6	BX0520	5.0	LH040
GNDM R/L2525M-312	25	25	150	25	25	36.6	3.0	12	3			
GNDM R/L2525M-418	25	25	150	25	25	45.0	4.0	18	4			
GNDM R/L2525M-518	25	25	150	25	25	45.0	5.0	18	5			
GNDM R/L2525M-618	25	25	150	25	25	45.0	6.0	18	6	BX0620	6.0	LH050
GNDM R/L3232P-312	32	32	170	32	32	36.6	3.0	12	3			
GNDM R/L3232P-418	32	32	170	32	32	45	4.0	18	4			
GNDM R/L3232P-518	32	32	170	32	32	45	5.0	18	5			
GNDM R/L3232P-618	32	32	170	32	32	45	6.0	18	6			
GNDM R/L3232P-718	32	32	170	32	32	50	7.0	18	7			
GNDM R/L3232P-818	32	32	170	32	32	50	8.0	18	8			

Select holders and inserts with the same grooving widths (w). Refer to page 296 for applicable inserts.

External L-Styled (Side Cut) Multi-purpose Type (Grooving, Turning, and Copying)

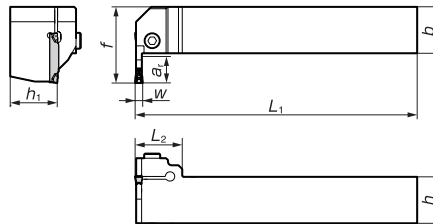
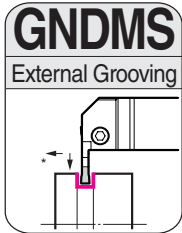

Above figures show right hand tools

■ Holders * Use the multi-purpose copying insert for turning (wide grooves).

■ Spare Parts

Catalog Number	Dimensions (mm)						Groove Width W(mm)	Max. Groove Depth a _r (mm)	Seat Size	Cap Screw	Recommended Tightening Torque (N-m)	Wrench
	h	b	L ₁	f	h ₁	L ₂						
GNDMS R/L 2020K-310	20	20	125	32	20	25	3.0	10	3	BX0520	5.0	LH040
GNDMS R/L 2020K-412	20	20	125	34	20	25	4.0	12	4			
GNDMS R/L 2020K-512	20	20	125	34	20	25	5.0	12	5			
GNDMS R/L 2525M-312	25	25	150	39	25	25	3.0	12	3			
GNDMS R/L 2525M-414	25	25	150	41	25	25	4.0	14	4			
GNDMS R/L 2525M-514	25	25	150	41	25	25	5.0	14	5			
GNDMS R/L 2525M-614	25	25	150	41	25	25	6.0	14	6			

Select holders and inserts with the same grooving widths (w). Refer to page 296 for applicable inserts.



External Multi-purpose Shallow Grooves Type (Grooving, Turning, and Copying)

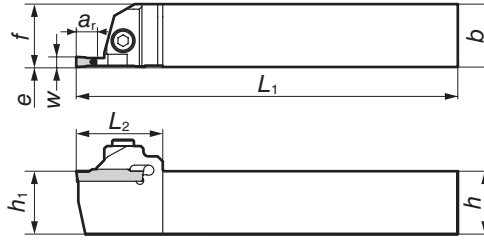
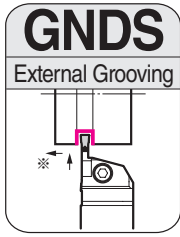

Above figures show right hand tools

■ Holders

* Use the multi-purpose copying insert for turning (wide grooves).

■ Spare Parts

Catalog Number	Dimensions (mm)						Groove Width	Max. Groove Depth a_r (mm)	Seat Size	Cap Screw	Recommended Tightening Torque (N-m)	Wrench
	h	b	L_1	f	h_1	L_2	W(mm)					
GNDS R/L2020K-206	20	20	125	20	20	30.0	2.0	6	2	BX0520	5.0	LH040
GNDS R/L2020K-306	20	20	125	20	20	30.0	3.0	6	3			
GNDS R/L2020K-410	20	20	125	20	20	34.0	4.0	10	4			
GNDS R/L2020K-510	20	20	125	20	20	34.0	5.0	10	5			
GNDS R/L2020K-610	20	20	125	20	20	34.0	6.0	10	6			
GNDS R/L2525M-206	25	25	150	25	25	30.0	2.0	6	2			
GNDS R/L2525M-306	25	25	150	25	25	30.0	3.0	6	3			
GNDS R/L2525M-410	25	25	150	25	25	34.0	4.0	10	4			
GNDS R/L2525M-510	25	25	150	25	25	34.0	5.0	10	5			
GNDS R/L2525M-610	25	25	150	25	25	34.0	6.0	10	6			

Select holders and inserts with the same grooving widths (w). Refer to page 296 for applicable inserts.



External Deep Grooving & Cut-Off

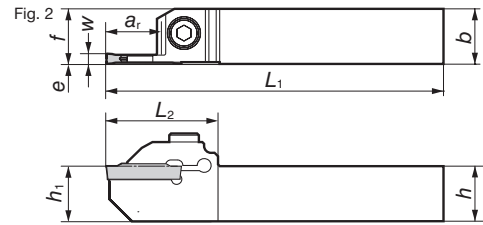
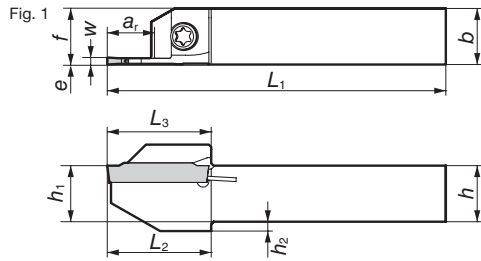
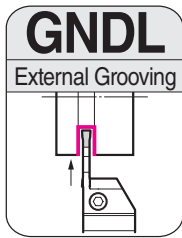

■ Holders

Above figures show right hand tools

■ Spare Parts

Catalog Number	Dimensions (mm)							Groove Width W(mm)	Max. Groove Depth a _r (mm)	Seat Size	Cap Screw	Recommended Tightening Torque (N-m)	Wrench
	h	b	L ₁	f	h ₁	L ₂	h ₂						
GNDL R/L1010JX-210	10	10	120	10	10	22.0	2.0	2.0	10	2	BFTX0412N	5.0	LT15-10
GNDL R/L1010JX-310	10	10	120	10	10	22.0	2.0	3.0	10	3			
GNDL R/L1212JX-212.5	12	12	120	12	12	22.0	2.0	2.0	12.5	2			
GNDL R/L1212JX-312.5	12	12	120	12	12	22.0	2.0	3.0	12.5	3	BX0515	5.0	LH040
GNDL R/L1616JX-216	16	16	120	16	16	32.0	-	2.0	16	2			
GNDL R/L1616JX-316	16	16	120	16	16	32.0	-	3.0	16	3	BX0520	5.0	LH040
GNDL R/L2020K-220	20	20	125	20	20	44.5	-	2.0	20	2			
GNDL R/L2020K-320	20	20	125	20	20	44.5	-	3.0	20(18)	3			
GNDL R/L2020K-425	20	20	125	20	20	50.0	-	4.0	25(23)	4			
GNDL R/L2020K-525	20	20	125	20	20	50.0	-	5.0	25(23)	5			
GNDL R/L2020K-625	20	20	125	20	20	50.0	-	6.0	25(23)	6			
GNDL R/L2525M-220	25	25	150	25	25	44.5	-	2.0	20	2			
GNDL R/L2525M-320	25	25	150	25	25	44.5	-	3.0	20(18)	3			
GNDL R/L2525M-425	25	25	150	25	25	50.0	-	4.0	25(23)	4			
GNDL R/L2525M-525	25	25	150	25	25	50.0	-	5.0	25(23)	5			
GNDL R/L2525M-625	25	25	150	25	25	50.0	-	6.0	25(23)	6	BX0620	6.0	LH050
GNDL R/L3232P-320	32	32	170	32	32	44.5	-	3.0	20	3			
GNDL R/L3232P-425	32	32	170	32	32	50	-	4.0	25	4			
GNDL R/L3232P-525	32	32	170	32	32	50	-	5.0	25	5			
GNDL R/L3232P-625	32	32	170	32	32	50	-	6.0	25	6			
GNDL R/L3232P-725	32	32	170	32	32	50	-	7.0	25	7			
GNDL R/L3232P-825	32	32	170	32	32	50	-	8.0	25	8			

Select holders and inserts with the same grooving widths (w). Dimensions in parentheses under maximum grooving depth are for applications that use copying inserts (RG Type Breakers). Refer to page 296 for applicable inserts.

External L-Styled (Side Cut) Grooving

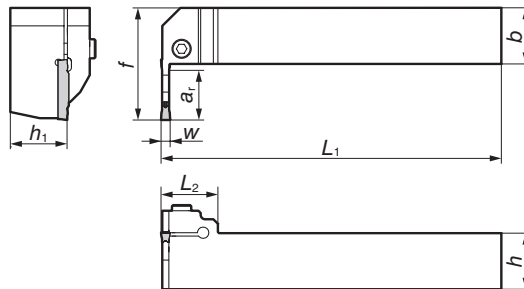
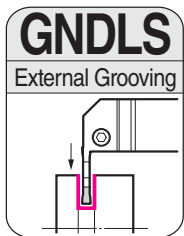

■ Holders

Above figures show right hand tools

■ Spare Parts

Catalog Number	Dimensions (mm)							Groove Width W(mm)	Max. Groove Depth a _r (mm)	Seat Size	Cap Screw	Recommended Tightening Torque (N-m)	Wrench
	h	b	L ₁	f	h ₁	L ₂							
GNDLS R/L2020K-216	20	20	125	38	20	25	2.0	16	2	BX0520	5.0	LH040	
GNDLS R/L2020K-316	20	20	125	38	20	25	3.0	16	3				
GNDLS R/L2525M-218	25	25	150	45	25	25	2.0	18	2				
GNDLS R/L2525M-318	25	25	150	45	25	25	3.0	18	3				
GNDLS R/L2525M-423	25	25	150	50	25	25	4.0	23	4				
GNDLS R/L2525M-523	25	25	150	50	25	25	5.0	23	5				
GNDLS R/L2525M-623	25	25	150	50	25	25	6.0	23	6				



Face Grooving

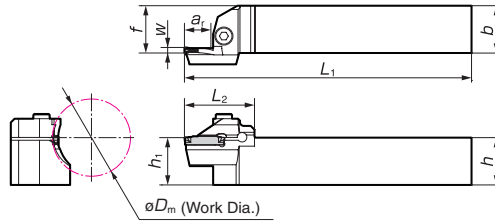
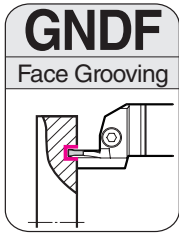

Above figures show right hand tools

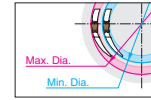

Work diameters in the stock table indicate external diameters of face grooves.

■ Holders

* Use the multi-purpose copying insert for turning (wide grooves).

■ Spare Parts

Catalog Number	Dimensions (mm)						Work Dia. (mm) ϕD_m	Groove Width W(mm)	Max. Groove Depth a_r (mm)	Seat Size	Cap Screw	Recommended Tightening Torque (N-m)	Wrench
	h	b	L ₁	f	h ₁	L ₂							
GNDF R/L2020K-312-035	20	20	125	20	20	35.6	35 to 45	3.0	12	3	BX0520	5.0	LH040
GNDF R/L2020K-312-040	20	20	125	20	20	35.6	40 to 55	3.0	12				
GNDF R/L2020K-318-050	20	20	125	20	20	41.6	50 to 70	3.0	18				
GNDF R/L2020K-318-065	20	20	125	20	20	41.6	65 to 100	3.0	18				
GNDF R/L2020K-318-090	20	20	125	20	20	41.6	90 to 150	3.0	18				
GNDF R/L2020K-318-140	20	20	125	20	20	41.6	140 to 200	3.0	18				
GNDF R/L2020K-318-180	20	20	125	20	20	41.6	180 to 300	3.0	18				
GNDF R/L2020K-418-040	20	20	125	20	20	41.6	40 to 55	4.0	18	4	BX0520	5.0	LH040
GNDF R/L2020K-423-050	20	20	125	20	20	46.6	50 to 70	4.0	23				
GNDF R/L2020K-423-065	20	20	125	20	20	46.6	65 to 90	4.0	23				
GNDF R/L2020K-423-085	20	20	125	20	20	46.6	85 to 130	4.0	23				
GNDF R/L2020K-423-125	20	20	125	20	20	46.6	125 to 200	4.0	23				
GNDF R/L2020K-423-180	20	20	125	20	20	46.6	180 to 300	4.0	23				
GNDF R/L2020K-423-280	20	20	125	20	20	46.6	280 to 1000	4.0	23				
GNDF R/L2020K-523-050	20	20	125	20	20	46.6	50 to 70	5.0	23	5	BX0520	5.0	LH040
GNDF R/L2020K-523-065	20	20	125	20	20	46.6	65 to 90	5.0	23				
GNDF R/L2020K-523-085	20	20	125	20	20	46.6	85 to 130	5.0	23				
GNDF R/L2020K-523-125	20	20	125	20	20	46.6	125 to 200	5.0	23				
GNDF R/L2020K-523-180	20	20	125	20	20	46.6	180 to 300	5.0	23				
GNDF R/L2020K-523-280	20	20	125	20	20	46.6	280 to 1000	5.0	23				
GNDF R/L2020K-623-050	20	20	125	20	20	46.6	50 to 75	6.0	23	6	BX0520	5.0	LH040
GNDF R/L2020K-623-070	20	20	125	20	20	46.6	70 to 110	6.0	23				
GNDF R/L2020K-623-100	20	20	125	20	20	46.6	100 to 200	6.0	23				
GNDF R/L2020K-623-180	20	20	125	20	20	46.6	180 to 300	6.0	23				
GNDF R/L2020K-623-280	20	20	125	20	20	46.6	280 to 1000	6.0	23				
GNDF R/L2525M-312-035	25	25	150	25	25	35.6	35 to 45	3.0	12				
GNDF R/L2525M-312-040	25	25	150	25	25	35.6	40 to 55	3.0	12				
GNDF R/L2525M-318-050	25	25	150	25	25	41.6	50 to 70	3.0	18				
GNDF R/L2525M-318-065	25	25	150	25	25	41.6	65 to 100	3.0	18				
GNDF R/L2525M-318-090	25	25	150	25	25	41.6	90 to 150	3.0	18				
GNDF R/L2525M-318-140	25	25	150	25	25	41.6	140 to 200	3.0	18				
GNDF R/L2525M-318-180	25	25	150	25	25	41.6	180 to 300	3.0	18				
GNDF R/L2525M-418-040	25	25	150	25	25	41.6	40 to 55	4.0	18	4	BX0520	5.0	LH040
GNDF R/L2525M-423-050	25	25	150	25	25	46.6	50 to 70	4.0	23				
GNDF R/L2525M-423-065	25	25	150	25	25	46.6	65 to 90	4.0	23				
GNDF R/L2525M-423-085	25	25	150	25	25	46.6	85 to 130	4.0	23				
GNDF R/L2525M-423-125	25	25	150	25	25	46.6	125 to 200	4.0	23				
GNDF R/L2525M-423-180	25	25	150	25	25	46.6	180 to 300	4.0	23				
GNDF R/L2525M-423-280	25	25	150	25	25	46.6	280 to 1000	4.0	23				
GNDF R/L2525M-523-050	25	25	150	25	25	46.6	50 to 70	5.0	23	5	BX0520	5.0	LH040
GNDF R/L2525M-523-065	25	25	150	25	25	46.6	65 to 90	5.0	23				
GNDF R/L2525M-523-085	25	25	150	25	25	46.6	85 to 130	5.0	23				
GNDF R/L2525M-523-125	25	25	150	25	25	46.6	125 to 200	5.0	23				
GNDF R/L2525M-523-180	25	25	150	25	25	46.6	180 to 300	5.0	23				
GNDF R/L2525M-523-280	25	25	150	25	25	46.6	280 to 1000	5.0	23				
GNDF R/L2525M-623-050	25	25	150	25	25	46.6	50 to 75	6.0	23	6	BX0520	5.0	LH040
GNDF R/L2525M-623-070	25	25	150	25	25	46.6	70 to 110	6.0	23				
GNDF R/L2525M-623-100	25	25	150	25	25	46.6	100 to 200	6.0	23				
GNDF R/L2525M-623-180	25	25	150	25	25	46.6	180 to 300	6.0	23				
GNDF R/L2525M-623-280	25	25	150	25	25	46.6	280 to 1000	6.0	23				

Select holders and inserts with the same grooving widths (w). Refer to page 296 for applicable inserts.



Grooving Toolholders

GND Series

GROOVING TOOLHOLDERS

GND SERIES

Series: GNDFS • GNDI

Face Grooving

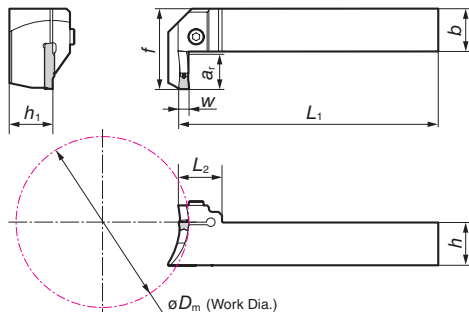
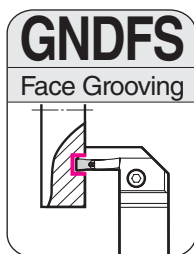

■ Spare Parts

Cap Screw	Recommended Tightening Torque (N-m)	Wrench
BX0520	5.0	LH040
BX0620	6.0	LH050
BX0620	6.0	LH050
BX0620	6.0	LH050

Catalog Number	Dimensions (mm)						Work Dia. (mm)	Groove Width w	Max. Groove Depth ar (mm)	Cap Screw	Recommended Tightening Torque (N-m)	Wrench
	h	b	L1	f	h1	L2						
GNDFS R/L2525M-620-070	25	25	150	47	25	25	70to100	6.0	20	BX0520	5.0	LH040
GNDFS R/L2525M-620-100	25	25	150	47	25	25	100to200	6.0	20			
GNDFS R/L2525M-620-180	25	25	150	47	25	25	180to300	6.0	20			
GNDFS R/L2525M-620-280	25	25	150	47	25	25	280to1000	6.0	20			
GNDFS R/L2525M-620-450	25	25	150	47	25	25	From 450	6.0	20			
GNDFS R/L3232P-620-070	32	32	170	54	32	25	70to100	6.0	20	BX0620	6.0	LH050
GNDFS R/L3232P-620-100	32	32	170	54	32	25	100to200	6.0	20			
GNDFS R/L3232P-620-180	32	32	170	54	32	25	180to300	6.0	20			
GNDFS R/L3232P-620-280	32	32	170	54	32	25	280to1000	6.0	20			
GNDFS R/L3232P-620-450	32	32	170	54	32	25	From 450	6.0	20			
GNDFS R/L2525M-820-070	25	25	150	47	25	30	70to100	8.0	20	BX0620	6.0	LH050
GNDFS R/L2525M-820-100	25	25	150	47	25	30	100to200	8.0	20			
GNDFS R/L2525M-820-180	25	25	150	47	25	30	180to300	8.0	20			
GNDFS R/L2525M-820-280	25	25	150	47	25	30	280to1000	8.0	20			
GNDFS R/L2525M-820-450	25	25	150	47	25	30	From 450	8.0	20			
GNDFS R/L3232P-820-070	32	32	170	54	32	30	70to100	8.0	20	BX0620	6.0	LH050
GNDFS R/L3232P-820-100	32	32	170	54	32	30	100to200	8.0	20			
GNDFS R/L3232P-820-180	32	32	170	54	32	30	180to300	8.0	20			
GNDFS R/L3232P-820-280	32	32	170	54	32	30	280to1000	8.0	20			
GNDFS R/L3232P-820-450	32	32	170	54	32	30	From 450	8.0	20			

Select holders and inserts with the same grooving widths (w).

GNDFS products made to order

Internal Grooving

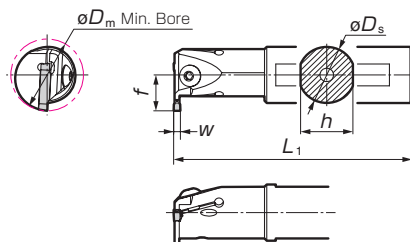
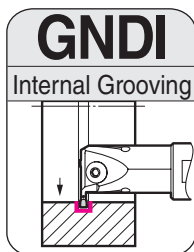

■ Metric Holders

Catalog Number	Dimensions (mm)					Max. Groove Depth ar (mm)	Seat Size
	Shank Diameter	h	Overall L1	f	Min. Bore Dm		
GNDIR/L2532-T206	25	23	200	16	32	6	2
GNDIR/L2532-T306	25	23	200	16	32	6	3
GNDIR/L2532-T406	25	23	200	16	32	6	4
GNDIR/L2532-T506	25	23	200	16	32	6	5
GNDIR/L3240-T210	32	30	250	26	40	10	2
GNDIR/L3240-T310	32	30	250	26	40	10	3
GNDIR/L3240-T410	32	30	250	26	40	10	4
GNDIR/L3240-T510	32	30	250	26	40	10	5
GNDIR/L4050-T311	40	38	300	31	50	11	3
GNDIR/L4050-T411	40	38	300	31	50	11	4
GNDIR/L4050-T511	40	38	300	31	50	11	5
GNDIR/L4050-T611	40	38	300	31	50	11	6

■ Inch Holders

Catalog Number	Dimensions (in)					Max Groove Depth W (inch)	Seat Size
	Shank Diameter	h	Overall L1	f	Min. Bore Dm		
GNDIR/L162T-25	1.000	0.906	8.000	0.630	1.250	0.250	2
GNDIR/L163T-25	1.000	0.906	8.000	0.630	1.250	0.250	3
GNDIR/L164T-25	1.000	0.906	8.000	0.630	1.250	0.250	4
GNDIR/L165T-25	1.000	0.906	8.000	0.630	1.250	0.250	5
GNDIR/L166T-25	1.000	0.906	8.000	0.630	1.250	0.250	6
GNDIR/L202T-40	1.250	1.181	10.000	1.024	1.575	0.400	2
GNDIR/L203T-40	1.250	1.181	10.000	1.024	1.575	0.400	3
GNDIR/L204T-40	1.250	1.181	10.000	1.024	1.575	0.400	4
GNDIR/L205T-40	1.250	1.181	10.000	1.024	1.575	0.400	5
GNDIR/L206T-40	1.250	1.181	10.000	1.024	1.575	0.400	6
GNDIR/L243T-43	1.500	1.421	12.000	1.145	2.000"	0.430	3
GNDIR/L244T-43	1.500	1.421	12.000	1.145	2.000"	0.430	4
GNDIR/L245T-43	1.500	1.421	12.000	1.145	2.000"	0.430	5
GNDIR/L246T-43	1.500	1.421	12.000	1.145	2.000"	0.430	6



GND SERIES

Series: Polygon Shank GND

Grooving Toolholders

Polygon Shank GND Series - Metric

Features and Benefits

- ISO Polygon shank holder
- Economic cassettes
- Compact and stable construction
- Repeatability of $\pm 2 \mu\text{m}$ interface
- Internal coolant supply directly from the holder to the cutting edge



Product Range - Holders

Application	Series	Shape	Grooving Width (mm)					Grooving Depth (mm)
			2	3	4	5	6	
External Grooving 	PSC_0M00R/L Straight		2	3				12
					4	5	6	18
	PSC_0M90R/L L-Style		2	3				12
					4	5	6	18

Note: 2mm Grooving width - please use only for grooving not for turning!

Identification Details - Polygon-Toolholder

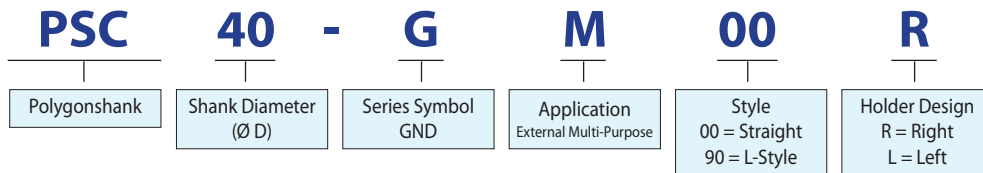

Identification Details - Cassette

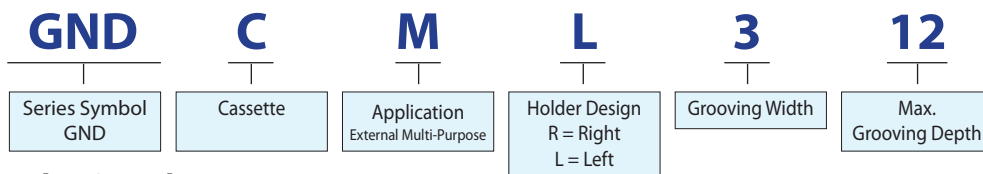

Selection Chart

Cassette	Grooving Width (mm)					Max. Grooving Depth	Chipbreaker							
	2	3	4	5	6		MG	ML	GG	GL	GF	RG	CG	GA
GNDCM R	Stock					12	○	○	○	○	○		○	○
GNDCM L	Stock					12	○	○	○	○	○		○	○
GNDCM R		Stock				12	○	○	○	○	○	○	○	○
GNDCM L		Stock				12	○	○	○	○	○	○	○	○
GNDCM R			Stock			18	○	○	○	○	○	○	○	○
GNDCM L			Stock			18	○	○	○	○	○	○	○	○
GNDCM R				Stock		18	○	○	○	○	○	○	○	○
GNDCM L				Stock		18	○	○	○	○	○	○	○	○

Stock

○ Recommendation



Threading, Grooving, & Cut-Off Holders

Application Examples

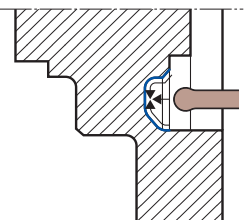
4120 Steel, Automotive Part, Face Profiling	
	Target: - Higher rigidity - Vibration reduction - Chip control - Wear resistance performance
	Holder: GND R2525M 423-125 Insert: GCM N4020 RG Grooving width: 0.16" (4mm) Cutting conditions: $v_c = 650$ SFM $f = .006$ IPR wet
Stable machining free of vibration! Excellent chip control using the GND type.	

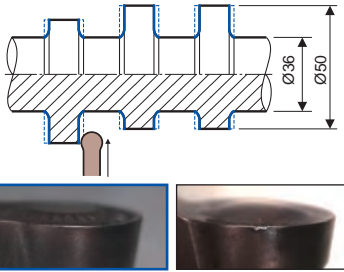
1053 Steel, Cam Shaft Grooving / Finishing (Contin. to Heavy Interrupted)	
	Target: - Higher rigidity - Vibration reduction - Chip control - Fracture resistance
	Holder: GNDM L2525M 618 Insert: GCM N6030 RG Grooving width: 0.24" (6mm) Cutting conditions: $v_c = 430$ SFM $f = .014$ IPR wet
Stable machining free of vibration! Excellent fracture resistance Stable chip control	

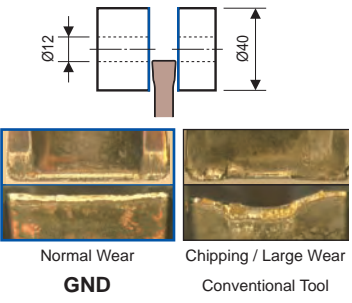
1048 Steel, Machine Part, Cut-Off	
 <p>Normal Wear GND Chipping / Large Wear Conventional Tool</p>	Target: - Higher rigidity - Vibration reduction - Fracture resistance
	Holder: GNDL R2525M 320 Insert: GCM N3002 GG Grooving width: 0.12" (3mm) Cutting conditions: $n = 1600$ min ⁻¹ $v_c = 650$ SFM $f = .002$ IPR wet
Stable machining free of vibration! Excellent fracture resistance Stable fracture resistance	

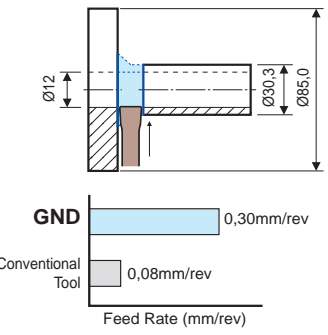
4137 Steel, Crank, Cut-Off	
 <p>GND 0,30mm/rev Conventional Tool 0,08mm/rev Feed Rate (mm/rev)</p>	Target: - Higher rigidity - Vibration reduction - Chip control
	Holder: GNDL R2525M 320 Insert: GCM N3002 GG Grooving width: 0.12" (3mm) Cutting conditions: $v_c = 380$ SFM $f = .012$ IPR wet
Improved efficiency Stable machining free of vibration! Stable chip control	

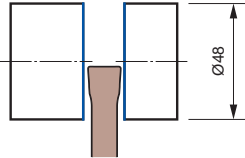
Hardened Steel (45-48HRC), Machine Part, Cut-Off	
	Target: - Higher rigidity - Vibration reduction - Chip control
	Holder: GNDL R2525M 425 Insert: GCM N4002 GG Grooving width: .16" (4mm) Cutting conditions: $v_c = 170$ SFM $f = .0012$ IPR wet
Stable machining free of vibration! Excellent chip control using the GND type. No more unexpected breakage!	

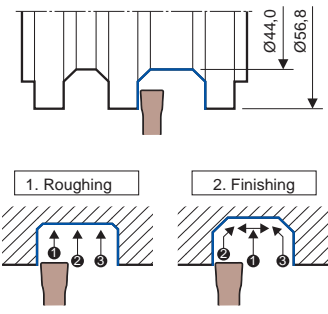
5120 Steel, Gear Shaft, Grooving / Pocketing	
	Target: - Higher rigidity - Vibration reduction - Chip control
	Holder: GNDM R2020K 518 Insert: GCM N5008 MG Grooving width: .20" (5mm) Cutting conditions: $v_c = 500$ SFM $f = .004$ IPR wet
Stable machining free of vibration! Excellent chip control using the GND type.	



External Multi-Purpose Type (Grooving, Turning, Profiling)

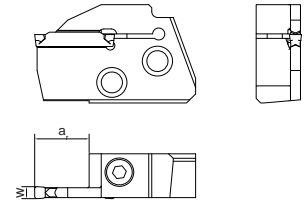
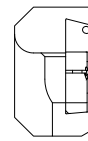
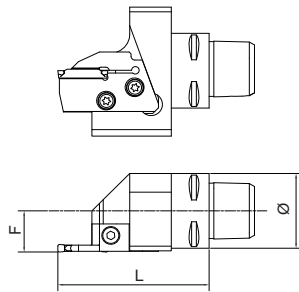
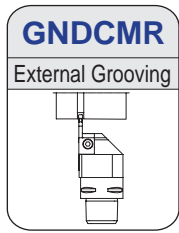

Use for multi-purpose or profiling insert for turning (wide grooves).

Above figures show right hand tools.

Holder (Right Hand)

Cat. No.	Stock	Ø	Direction	F	L	Cap Screw	Tightening Torque (N-m)	Wrench
PSC40GM00R	★	40 mm	right	22 mm	80 mm	BFTX0619N	7.5	TRD25
PSC50GM00R	★	50mm	right	27 mm	80 mm			

Cassette

Cat. No.	Stock	Direction	Grooving Width w (mm)	Grooving Depth a _r (mm)	Inserts	Cap Screw	Tightening Torque (N-m)	Wrench
GNDCMR212	★	right	2	12	GCM □2002-□□	BX0515	5.0	LH040
GNDCMR312	★	right	3	12	GCM □30□□-□□			
GNDCMR418	★	right	4	18	GCM □40□□-□□		6.0	
GNDCMR518	★	right	5	18	GCM □50□□-□□			
GNDCMR618	★	right	6	18	GCM □60□□-□□			

★: Worldwide Warehouse Item

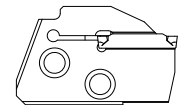
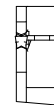
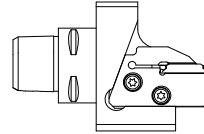
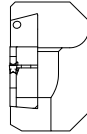
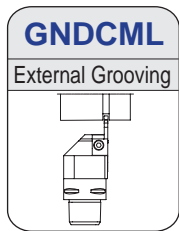

Use for multi-purpose or profiling insert for turning (wide grooves).

Above figures show right hand tools.

Holder

Cat. No.	Stock	Ø	Direction	F	L	Cap Screw	Tightening Torque (N-m)	Wrench
PSC40GM00L	★	40 mm	left	22 mm	80 mm	BFTX0619N	7.5	TRD25
PSC50GM00L	★	50 mm	left	27 mm	80 mm			

Cassette

Cat. No.	Stock	Direction	Grooving Width w (mm)	Grooving Depth a _r (mm)	Inserts	Cap Screw	Tightening Torque (N-m)	Wrench
GNDCML212	★	left	2	12	GCM □2002-□□	BX0515	5.0	LH040
GNDCML312	★	left	3	12	GCM □30□□-□□			
GNDCML418	★	left	4	18	GCM □40□□-□□		6.0	
GNDCML518	★	left	5	18	GCM □50□□-□□			
GNDCML618	★	left	6	18	GCM □60□□-□□			

★: Worldwide Warehouse Item



Grooving Toolholders

Polygon Shank GND Series - Metric

GROOVING TOOLHOLDERS

GND SERIES

Series: Polygon Shank GND

Threading,
Grooving, &
Cut-Off Holders

External Multi-Purpose Type (Grooving, Turning, Profiling)

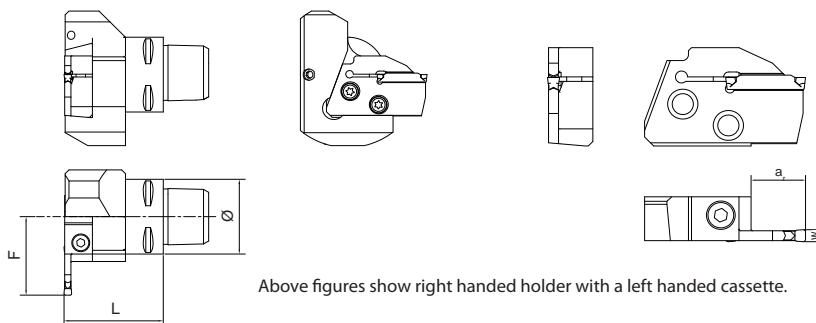
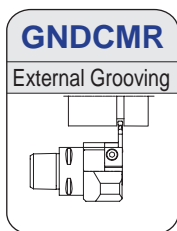

Use for multi-purpose or profiling insert for turning (wide grooves).

Above figures show right handed holder with a left handed cassette.

Holder

Cat. No.	Stock	Ø	Direction	F	L	Cap Screw	Tightening Torque (N-m)	Wrench
PSC40GM90R	★	40 mm	right	22 mm	80 mm	BFTX0619N	7.5	TRD25
PSC50GM90R	★	50 mm	right	27 mm	80 mm			

Cassette

Cat. No.	Stock	Direction	Grooving Width w (mm)	Grooving Depth a (mm)	Inserts	Cap Screw	Tightening Torque (N-m)	Wrench
GNDCML212	★	left	2	12	GCM □2002-□□	BX0515	5.0	LH040
GNDCML312	★	left	3	12	GCM □30□□-□□			
GNDCML418	★	left	4	18	GCM □40□□-□□		6.0	
GNDCML518	★	left	5	18	GCM □50□□-□□			
GNDCML618	★	left	6	18	GCM □60□□-□□			

★: Worldwide Warehouse Item

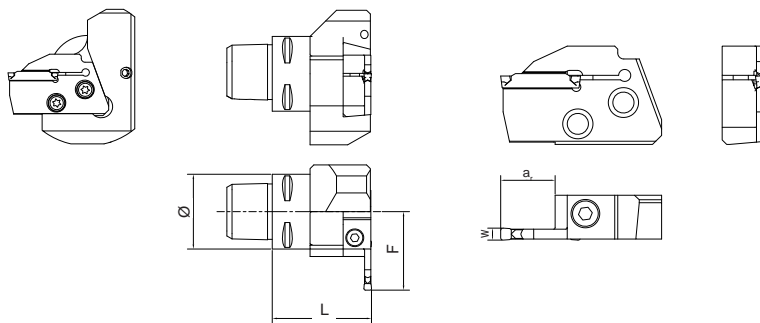
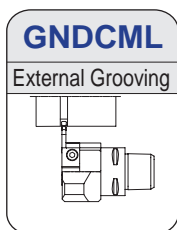

Use for multi-purpose or profiling insert for turning (wide grooves).

Above figures show left handed holder with a right handed cassette.

Holder

Cat. No.	Stock	Ø	Direction	F	L	Cap Screw	Tightening Torque (N-m)	Wrench
PSC40GM90L	★	40 mm	left	22 mm	80 mm	BFTX0619N	7.5	TRD25
PSC50GM90L	★	50 mm	left	27 mm	80 mm			

Cassette

Cat. No.	Stock	Direction	Grooving Width w (mm)	Grooving Depth a (mm)	Inserts	Cap Screw	Tightening Torque (N-m)	Wrench
GNDCMR212	★	right	2	12	GCM □2002-□□	BX0515	5.0	LH040
GNDCMR312	★	right	3	12	GCM □30□□-□□			
GNDCMR418	★	right	4	18	GCM □40□□-□□		6.0	
GNDCMR518	★	right	5	18	GCM □50□□-□□			
GNDCMR618	★	right	6	18	GCM □60□□-□□			

★: Worldwide Warehouse Item



GND SERIES

Series: GCM Inserts

Grooving Toolholders

GND Series - Inserts

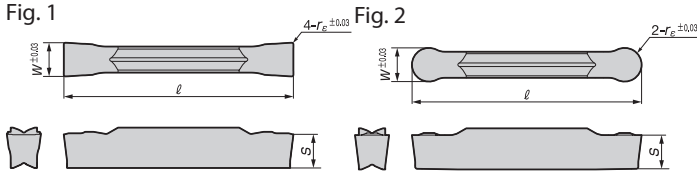

Multi Purpose / General Feed MG Chipbreaker | Multi Purpose / Low Feed ML Chipbreaker | Grooving / General Feed GG Chipbreaker | Grooving / Low Feed GL Chipbreaker | Profiling / General Feed RG Chipbreaker | Low Cutting Force GF Chipbreaker | For Non-Ferrous Material GA Chipbreaker | For Cut-off Application GO Chipbreaker

Threading, Grooving, & Cut-Off Holders

Type	Cat. No.	Coated Carbide					Cermet	Uncoated Carbide	Dimensions (inch)					Figure
		S		K	P		N	W	rE	l	Seat	S		
		AC520U	AC530U	AC425K	AC830P	T2500A	H10							
Deep Grooving Cut Off	General Feed GG Type	GCMN2002-GG	●	●	●	●			.078	.0078	.831	2	.142	1
	GCMN2094R0.5-GG	●	●	●	●			.094	.0078	.831	2	.142		
	GCMN3002-GG	●	●	●	●			.118	.0078	.831	3	.150		
	GCMN3004-GG	●	●	●	●			.118	.0156	.831	3	.150		
	GCMN3125R0.5-GG	●	●	●	●			.125	.0078	.831	3	.150		
	GCMN4002-GG	●	●	●	●			.157	.0078	1.039	4	.157		
	GCMN4004-GG	●	●	●	●			.157	.0156	1.039	4	.157		
	GCMN5187R0.5-GG	●	●	●	●			.187	.0078	1.039	5	.161		
	GCMN5002-GG	●	●	●	●			.197	.0078	1.039	5	.161		
	GCMN5004-GG	●	●	●	●			.197	.0156	1.039	5	.161		
	GCMN6002-GG	●	●	●	●			.236	.0078	1.039	6	.177		
	GCMN6004-GG	●	●	●	●			.236	.0156	1.039	6	.177		
	GCMN6250R0.5-GG	●	●	●	●			.250	.0078	1.039	6	.177		
	GCMN6250R1.0-GG	●	●	●	●			.250	.0156	1.039	6	.177		
	GCMN7004-GG	●	●	●	●			.276	.0156	1.132	7	.217		
	GCMN8004-GG	●	●	●	●			.315	.0156	1.132	8	.236		
	Low Feed GL Type	GCMN2002-GL	●	●	●	●	○		.078	.0078	.831	2	.142	
	GCMN2094R0.5-GL	●	●	●	●	●	○		.094	.0078	.831	2	.142	
	GCMN3002-GL	●	●	●	●	●	○		.118	.0078	.831	3	.150	
	GCMN3125R0.5-GL	●	●	●	●	●			.125	.0078	.831	3	.150	
	GCMN4002-GL	●	●	●	●	●	○		.157	.0078	1.039	4	.157	
	GCMN5187R0.5-GL	●	●	●	●	●			.187	.0078	1.039	5	.161	
	GCMN5002-GL	●	●	●	●	●			.197	.0078	1.039	5	.161	
	GCMN6002-GL	●	●	●	●	●			.236	.0078	1.039	6	.177	
GCMN6250R0.5-GL	●	●	●	●	●			.250	.0078	1.039	6	.177		
GCMN7004-GL	●	●	●	●	●			.276	.0156	1.132	7	.217		
GCMN8004-GL	●	●	●	●	●			.315	.0156	1.132	8	.236		
Multi function (traversing)	General Feed MG Type	GCMN3004-MG	●	●	●	●			.118	.0156	.831	3	.150	
	GCMN3125R1.0-MG	●	●	●	●	●			.125	.0156	.831	3	.150	
	GCMN4008-MG	●	●	●	●	●			.157	.0312	1.039	4	.157	
	GCMN5187R2.0-MG	●	●	●	●	●			.187	.0312	1.039	5	.161	
	GCMN5008-MG	●	●	●	●	●			.197	.0312	1.039	5	.161	
	GCMN6008-MG	●	●	●	●	●			.236	.0312	1.039	6	.177	
	GCMN6250R2.0-MG	●	●	●	●	●			.250	.0312	1.039	6	.177	
	GCMN7008-MG	●	●	●	●	●			.276	.0313	1.132	7	.217	
	GCMN8008-MG	●	●	●	●	●			.315	.0313	1.132	8	.236	
	Low Feed ML Type	GCMN3002-ML	●	●	●	●	○		.118	.0078	.831	3	.150	
	GCMN3125R0.5-ML	●	●	●	●	●			.125	.0078	.831	3	.150	
	GCMN4004-ML	●	●	●	●	●	○		.157	.0156	1.039	4	.157	
	GCMN5187R1.0-ML	●	●	●	●	●			.187	.0156	1.039	5	.161	
	GCMN5004-ML	●	●	●	●	●			.197	.0156	1.039	5	.161	
	GCMN6004-ML	●	●	●	●	●			.236	.0156	1.039	6	.177	
	GCMN6250R1.0-ML	●	●	●	●	●			.250	.0156	1.039	6	.177	
	GCMN7004-ML	●	●	●	●	●			.276	.0156	1.132	7	.217	
	GCMN8004-ML	●	●	●	●	●			.315	.0156	1.132	8	.236	
	Profiling	General Feed RG Type	GCMN3015-RG	●	●	●	●	○		.118	.059	.831	3	.150
		GCMN3125-RG	●	●	●	●	●			.125	.0625	.831	3	.150
		GCMN4020-RG	●	●	●	●	●	○		.157	.078	1.039	4	.157
		GCMN5187-RG	●	●	●	●	●			.187	.0938	1.039	5	.161
		GCMN5025-RG	●	●	●	●	●			.197	.098	1.039	5	.161
		GCMN6030-RG	●	●	●	●	●			.236	.118	1.039	6	.177
GCMN6250-RG		●	●	●	●	●			.250	.125	1.039	6	.177	
GCMN7035-RG		●	●	●	●	●			.276	.138	1.144	7	.217	
GCMN8040-RG	●	●	●	●	●			.315	.157	1.152	8	.236		



GND Series - Inserts Cont'd

Type	Cat. No.	Coated Carbide						Cermet	Uncoated Carbide	Dimensions (inch)					Figure											
		S		K		P				N	W	r _e	ℓ	Seat		S										
		AC520U	AC530U	AC425K	AC830P	T2500A	H10																			
For Non-ferrous Materials	GA Type	GCGN2002-GA							○	.078	.0078	.831	2	.142	1											
		GCGN3002-GA							○	.118	.0078	.831	3	.150												
		GCGN4004-GA							○	.157	.0156	1.039	4	.157												
		GCGN5004-GA							○	.197	.0156	1.039	5	.161												
		GCGN6004-GA							○	.236	.0156	1.039	6	.177												
Type	Cat. No.	R	L	R	L	R	L	R	L	R	L	R	L	Dimensions (inch)					Figure							
Cut-off (Handed)	CG-05 Type	GCM_2002-CG-05	●	●	●	●	●	●	●	●	●										.078	.0078	.831	2	.142	1
		GCM_3002-CG-05	●	●	●	●	●	●	●	●	●	●									.118	.0078	.831	3	.150	
		GCM_4002-CG-05	●	●	●	●	●	●	●	●	●	●								.157	.0078	1.039	4	.157		

Notes on Attaching Inserts

- Remove any debris or oil from the insert seat before attaching the insert.
- Grind off any burr or flaws on the insert seat.
- Slide the insert flat over its seat.
- Clamp the insert with its opposite end (the holder side) firmly against the supporting surface.
- The recommended tightening torque is **5 N·m**. Tightening above the recommended torque may damage the insert which could cause injury and other accidents.

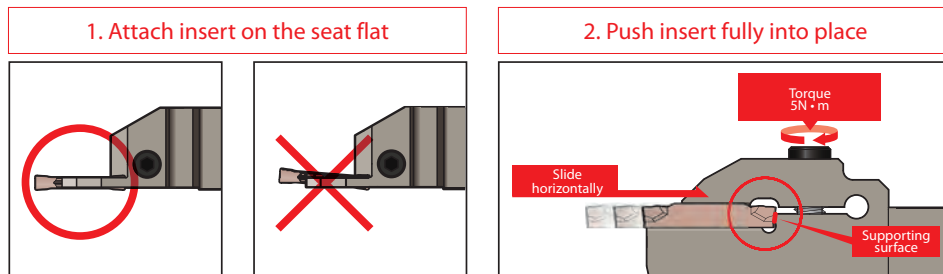

Notes on Attaching Holders

- Remove any debris or oil from the tool post before attaching the holder.
- Grind off any burr or flaws on the tool post.
- Attach the insert so that it is perpendicular to the workpiece.
- Set holder with shortest possible overhang.

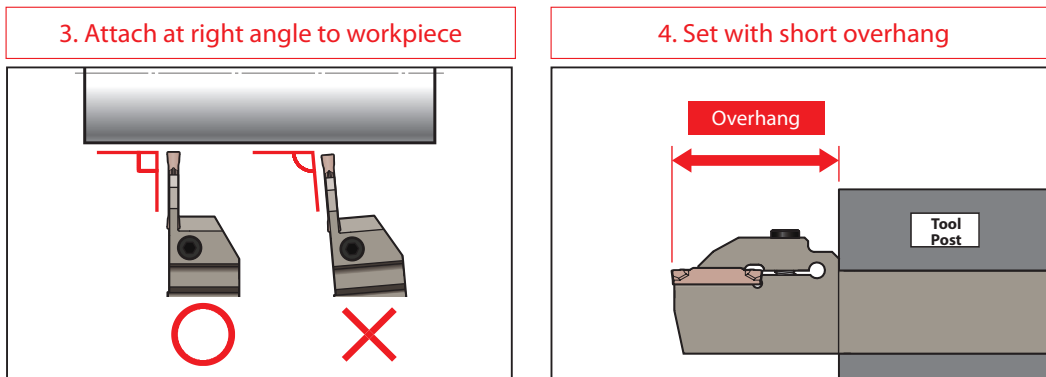

Notes on Setting Coolant Supply Nozzle

- Set the coolant supply nozzle so that coolant can be supplied from the top of the upper clamp unit.

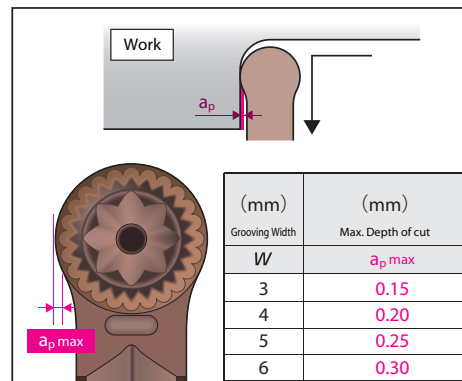
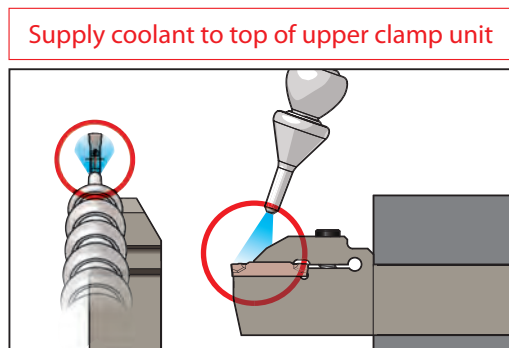

SumiTurn B-Groove System for Internal & External Grooving

Characteristics of GWC Series

- Similar insert can be used for both external and internal grooving
- Full range of insert grades to cover a wide range of work materials available:
 - Coated Carbide: AC530U
 - Uncoated Carbide: H1
 - Coated Cermet: T3000Z
 - Cermet: T1500A/T1200A
 - SUMIBORON: BN2000/BN250
 - SUMIDIA: DA2200
- A wide variation of grooving widths from 0.33mm to 4.8mm
- Insert with Chipbreaker, **SumiTurn B-Groove**, are now stocked
- Customers can modify the grooving width, nose radius and rake angle according to their own requirements using the grooving insert blanks (* Sumitomo Electric Hardmetal also accepts special orders.)

External Shallow Grooves

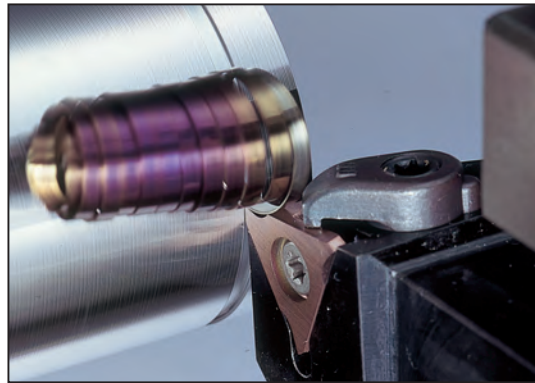

Threading, Grooving, & Cut-Off Holders

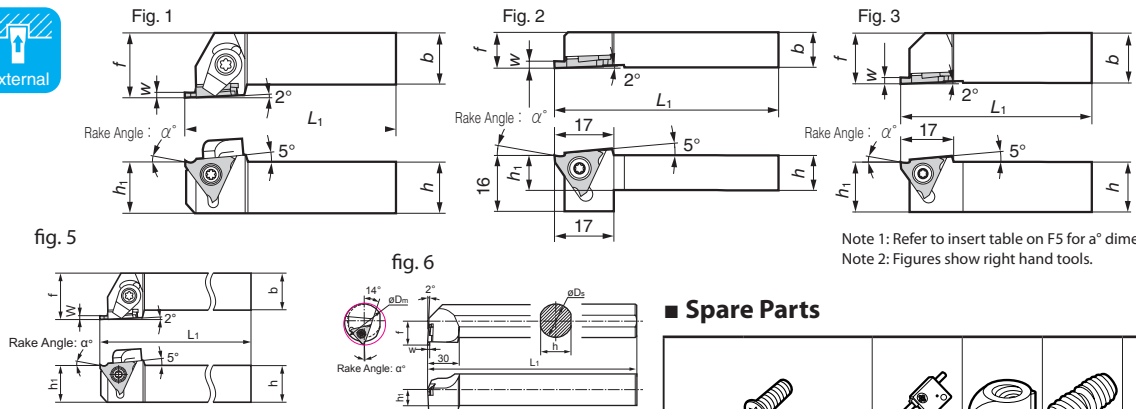
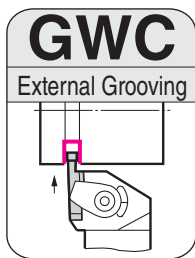

Note 1: Refer to insert table on F5 for α° dimensions.
Note 2: Figures show right hand tools.

■ **Holders** Right handed holders are applicable with right handed inserts.

■ Spare Parts

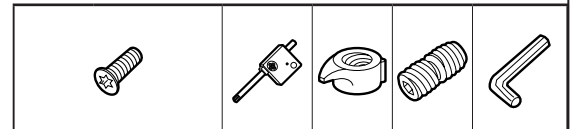

	Cat. No.	Stock		Dimensions mm/(in.)					Fig.	Grooving Width w mm/(in.)	Max. Grooving Depth mm/(in.)	* Group No.	Screw	Recommended Tightening Torque (N•m)	Wrench	Clamp	Double Screw	Spanner	
		R	L	h	b	L ₁	f	h ₁											
Metric	GWC R/L1010-3	★	★	10	10	125	10	10	2	0.33 to 2.80	0.8 to 2.5	1	BFTX0409N	3.4	TRX15	-	-	-	
	GWC R/L1212-3	★	★	12	12	125	12	12	2	0.33 to 2.80	0.8 to 2.5	1							
	GWC R/L1616-3	★	★	16	16	125	16	16	3	0.33 to 2.80	0.8 to 2.5	1							
	Metric	GWC R/L2020-3	★	★	20	20	125	25	20	1	0.33 to 2.80	0.8 to 2.5	1	BFTX0409N	3.4	TRX15	CCM6B L/R	WB6-20T/TL	LT20
		GWC R/L2525-3	★	★	25	25	150	30	25	1	0.33 to 2.80	0.8 to 2.5	1						
		GWC R/L2020-15	★	★	20	20	125	25	20	1	1.00 to 1.45	2.0	2						
		GWC R/L2020-25	★	★	20	20	125	25	20	1	1.50 to 2.30	3.5	3						
		GWC R/L2020-35	★	★	20	20	125	25	20	1	2.50 to 4.80	5.0	4						
		GWC R/L2525-15	★	★	25	25	150	30	25	1	1.00 to 1.45	2.0	2						
		GWC R/L2525-25	★	★	25	25	150	30	25	1	1.50 to 2.30	3.5	3						
Inch	GWC R/L2525-35	★	★	25	25	150	30	25	1	2.50 to 4.80	5.0	4	BFTX0511N	5.0	TRX20	CCM8U L/R	WB8-22T/TL	LT27	
	GWC R/L124C-25	•	•	(0.75)	(0.75)	(5.00)	(0.938)	(0.75)	5	(0.060 - 0.090)	(0.1378)	3							
	GWC R/L124C-35	•	•	(0.75)	(0.75)	(5.00)	(0.938)	(0.75)		(0.100 - 0.189)	(0.1969)	4							
	GWC R/L164D-25	•	•	(1.00)	(1.00)	(6.00)	(1.18)	(1.00)		(0.060 - 0.090)	(0.1378)	3							
GWC R/L164D-35	•	•	(1.00)	(1.00)	(6.00)	(1.18)	(1.00)	(0.100 - 0.189)		(0.1969)	4								
Internal				Dimensions mm/(in.)					Min Bore	Grooving Width	Max. Grooving	Fig.	Screw	Recommended Tightening Torque (N•m)	Wrench	Rake Angle with Insert fitted on holder (α°) AC530U EXTERNAL: GWC R/L 10° INTERNAL: GWCI R/L 1°			
				h	b	L ₁	f	h ₁	ϕ Dm	w mm/(in.)	Depth mm/(in.)								
				25	23	200	17.5	11.5	35	0.33 - 2.80	0.5 - 2.0								
				32	30	250	22.5	15.0	40	1.25 - 4.80	1.7 - 2.5								
			(1.250)	(1.181)	(10.00)	(0.890)	(0.590)	(1.580)	(0.050 - 0.189)	(0.070 - 0.100)									

* Refer to pages F6, F7, and F8 for applicable TGA type inserts. Select applicable inserts for the holders by using matching group numbers.



SumiTurn B-Groove System for Internal & External Grooving

SUMITURN
B-GROOVE
TGA Inserts

■ INSERTS

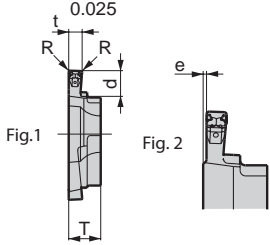
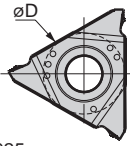

Grade	Cutting Edge	P
Coated Carbide	AC530U	Honing 15°
Carbide	H1	Sharp 25°
Coated Cermet	T3000Z	Honing 15°
Cermet	T1500A	Sharp 10°
	T1200A	Sharp 10°
SUMIBORON	BN2000	Neg. Land 5°
	BN250	Neg. Land 5°
SUMIDIA	DA2200	Sharp 15°

* For rake angle when fitted on the holder, refer to page F5.

Sumitomo Cat. No.	AC530U		Tooth t	Dimensions mm (in)				Max. Groove Depth		Fig.	Holder(s)							
	R	L		e	R	D	T	d	OD			ID						
TGA R/L4150BF	★	★	1.50	0.250	0.2	12.70	4.76	3.9	3.5	2.5	2	GWC R/L2020-25 GWC R/L2525-25 GWCI R/L432						
TGA R/L4165BF	★	★	1.65	0.175														
TGA R/L4175BF	★	★	1.75	0.125														
TGA R/L4185BF	★	★	1.85	0.075														
TGA R/L4200BF	★	★	2.00	0.000														
TGA R/L4220BF	★	★	2.20															
TGA R/L4230BF	★	★	2.30															
TGA R/L4250BF	★	★	2.50															
TGA R/L4265BF	★	★	2.65															
TGA R/L4270BF	★	★	2.70															
TGA R/L4280BF	★	★	2.80	0.3	12.70	4.76	5.4	5.0	2.5	1	GWC R/L2525-35 GWCI R/L432							
TGA R/L4300BF	★	★	3.00															
TGA R/L4320BF	★	★	3.20															
TGA R/L4330BF	★	★	3.30															
TGA R/L4350BF	★	★	3.50															
TGA R/L4370BF	★	★	3.70															
TGA R/L4390BF	★	★	3.90															
TGA R/L4400BF	★	★	4.00															
TGA R/L4410BF	★	★	4.10															
TGA R/L4420BF	★	★	4.20															
TGA R/L4430BF	★	★	4.30	0.4	(0.500)	(0.187)	(0.213)	(0.197)	(0.098)	1	GWC R/L2525-35 GWCI R/L432							
TGA R/L4440BF	★	★	4.40															
TGA R/L4450BF	★	★	4.50															
TGA R/L40062BF	●	●	(0.062)									(0.016)						
TGA R/L40072BF	●	●	(0.072)									(0.010)						
TGA R/L40088BF	●	●	(0.088)									(0.003)						
TGA R/L40094BF	●	●	(0.094)									(0.000)	(0.012)	(0.154)	(0.138)	(0.098)	2	GWC R/L2020-25 GWC R/L2525-25 GWCI R/L432
TGA R/L40097BF	●	●	(0.097)															
TGA R/L40105BF	●	●	(0.105)															
TGA R/L40110BF	●	●	(0.110)															
TGA R/L40122BF	●	●	(0.122)															
TGA R/L40125BF	●	●	(0.125)															
TGA R/L40142BF	●	●	(0.142)															
TGA R/L40156BF	●	●	(0.156)	(0.016)														

Cat. No. (Add E to the end of the Cat. No. for T1500A grades)	Coated Carbide		Carbide		Coated Cermet		Cermet		SUMIBORON		SUMIDIA		Grooving Width (mm) w	Max. Grooving Depth (mm)		Dimensions (mm)				Group No.*		
	AC530U		H1		T3000Z		T1500A		BN2000		DA2200			External	Internal	a	r _E	ød	s			
	R	L	R	L	R	L	R	L	R	L	R	L										
TGA R/L3033(E)	★	★	★	★	★	★	★	★	★	★	★	★	★	★	0.33	0.8	0.5	1.0	0.05	9.525	3.18	1
TGA R/L3050(E)	★	★	★	★	★	★	★	★	★	★	★	★	★	★	0.50	1.2	0.8	1.4				
TGA R/L3075(E)	★	★	★	★	★	★	★	★	★	★	★	★	★	★	0.75	2.0	1.5	2.5				
TGA R/L3095(E)	★	★	★	★	★	★	★	★	★	★	★	★	★	★	0.95							
TGA R/L3100(E)	★	★	★	★	★	★	★	★	★	★	★	★	★	★	1.00							
TGA R/L3110(E)	★	★	★	★	★	★	★	★	★	★	★	★	★	★	1.10							
TGA R/L3125(E)	★	★	★	★	★	★	★	★	★	★	★	★	★	★	1.25							
TGA R/L3135(E)	★	★	★	★	★	★	★	★	★	★	★	★	★	★	1.35							
TGA R/L3145(E)	★	★	★	★	★	★	★	★	★	★	★	★	★	★	1.45							
TGA R/L3150(E)	★	★	★	★	★	★	★	★	★	★	★	★	★	★	1.50							
TGA R/L3165(E)	★	★	★	★	★	★	★	★	★	★	★	★	★	★	1.65							
TGA R/L3175(E)	★	★	★	★	★	★	★	★	★	★	★	★	★	★	1.75							
TGA R/L3185(E)	★	★	★	★	★	★	★	★	★	★	★	★	★	★	1.85							
TGA R/L3200(E)	★	★	★	★	★	★	★	★	★	★	★	★	★	★	2.00	2.5	2.0	3.0				
TGA R/L3220(E)	★	★	★	★	★	★	★	★	★	★	★	★	★	★	2.20							
TGA R/L3230(E)	★	★	★	★	★	★	★	★	★	★	★	★	★	★	2.30							
TGA R/L3250(E)	★	★	★	★	★	★	★	★	★	★	★	★	★	★	2.50							
TGA R/L3265(E)	★	★	★	★	★	★	★	★	★	★	★	★	★	★	2.65							
TGA R/L3270(E)	★	★	★	★	★	★	★	★	★	★	★	★	★	★	2.70							
TGA R/L3280(E)	★	★	★	★	★	★	★	★	★	★	★	★	★	★	2.80							
TGA R/L4125(E)	★	★	★	★	★	★	★	★	★	★	★	★	★	★	1.25				2.0	1.7	2.5	
TGA R/L4145(E)	★	★	★	★	★	★	★	★	★	★	★	★	★	★	1.45							
TGA R/L4150(E)	★	★	★	★	★	★	★	★	★	★	★	★	★	★	1.50							
TGA R/L4165(E)	★	★	★	★	★	★	★	★	★	★	★	★	★	★	1.65							
TGA R/L4175(E)	★	★	★	★	★	★	★	★	★	★	★	★	★	★	1.75							
TGA R/L4185(E)	★	★	★	★	★	★	★	★	★	★	★	★	★	★	1.85							
TGA R/L4200(E)	★	★	★	★	★	★	★	★	★	★	★	★	★	★	2.00							
TGA R/L4220(E)	★	★	★	★	★	★	★	★	★	★	★	★	★	★	2.20							
TGA R/L4230(E)	★	★	★	★	★	★	★	★	★	★	★	★	★	★	2.30							
TGA R/L4250(E)	★	★	★	★	★	★	★	★	★	★	★	★	★	★	2.50							
TGA R/L4265(E)	★	★	★	★	★	★	★	★	★	★	★	★	★	★	2.65	5.0	2.5	5.4				
TGA R/L4270(E)	★	★	★	★	★	★	★	★	★	★	★	★	★	★	2.70							
TGA R/L4280(E)	★	★	★	★	★	★	★	★	★	★	★	★	★	★	2.80							
TGA R/L4300(E)	★	★	★	★	★	★	★	★	★	★	★	★	★	★	3.00							
TGA R/L4320(E)	★	★	★	★	★	★	★	★	★	★	★	★	★	★	3.20							
TGA R/L4330(E)	★	★	★	★	★	★	★	★	★	★	★	★	★	★	3.30							
TGA R/L4350(E)	★	★	★	★	★	★	★	★	★	★	★	★	★	★	3.50							
TGA R/L4370(E)	★	★	★	★	★	★	★	★	★	★	★	★	★	★	3.70							
TGA R/L4390(E)	★	★	★	★	★	★	★	★	★	★	★	★	★	★	3.90							
TGA R/L4400(E)	★	★	★	★	★	★	★	★	★	★	★	★	★	★	4.00							
TGA R/L4410(E)	★	★	★	★	★	★	★	★	★	★	★	★	★	★	4.10	5.0	2.5	5.4				
TGA R/L4420(E)	★	★	★	★	★	★	★	★	★	★	★	★	★	★	4.20							
TGA R/L4430(E)	★	★	★	★	★	★	★	★	★	★	★	★	★	★	4.30							
TGA R/L4440(E)	★	★	★	★	★	★	★	★	★	★	★	★	★	★	4.40							
TGA R/L4450(E)	★	★	★	★	★	★	★	★	★	★	★	★	★	★	4.50							
TGA R/L4480(E)	★	★	★	★	★	★	★	★	★	★	★	★	★	★	4.80							

* Select applicable inserts for the holders by using matching group numbers.

*1: SUMIBORON, SUMIDIA is a = 4.4 (4.0)

*2: SUMIBORON is r_E = 0.2, SUMIDIA is r_E = 0.1

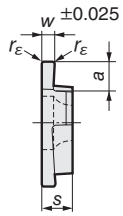
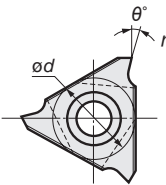

Above figures show right hand tools.

- : USA Stocked Item
- ★: Worldwide Warehouse Item
- ▲: USA Limited Availability Item



Threading,
Grooving, &
Cut-Off Holders

■ SUMINOTCH GROOVING TOOLHOLDERS

SS Series

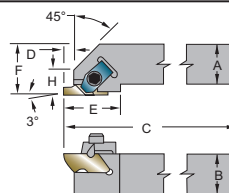
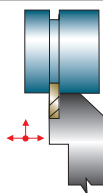
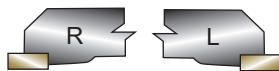

Catalog Number		Applicable Insert		A	B	C	D	E	F	H			
Right	Left	R.H.	L.H.								Right Hand Clamp	Left Hand Clamp	Screw
SSR062	SSL062			.375	.375	2.5	.138	1.25	.562	.50			
SSR-82V	SSL-82V			.500	.500	3.5	.138	1.25	.750	.50			
SSR-102B	SSL-102B	SG-2R	SG-2L	.625	.625	4.5	.138	1.25	.875	.50	TF74	TF75	S-310 / ST1291
SSR-122B	SSL-122B			.750	.750	4.5	.138	1.25	1.000	.50			
SSR-162C	SSL-162C			1.000	1.000	5.0	.138	1.25	1.250	.50			
SSR-123A	SSL-123A			.750	.750	4.0	.210	1.25	1.000	.50			
SSR-123B	SSL-123B			.750	.750	4.5	.210	1.25	1.000	.50			
SSR-163C	SSL-163C	SG-3R	SG-3L	1.000	1.000	5.0	.210	1.25	1.250	.50	TF72	TF73	S-412 / ST-1297
SSR-163D	SSL-163D			1.000	1.000	6.0	.210	1.25	1.250	.50			
SSR-203D	SSL-203D			1.250	1.250	6.0	.210	1.25	1.500	.50			

SE Series

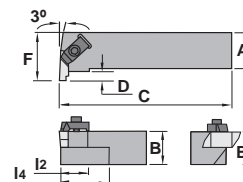
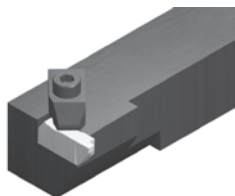

Catalog Number		Applicable Insert		A	B	l ₂	C	l ₄	D	F			
Right	Left	R.H.	L.H.								Right Hand Clamp	Left Hand Clamp	Screw
SER062	SEL062			.375	.375	.500	2.5	1.000	.138	.750			
SER082J	SEL082J			.500	.500	.500	3.5	1.000	.138	.750			
SER102B	SEL102B	SG-2R	SG-2L	.625	.625	-	4.5	1.000	.138	.750	TF74	TF75	ST-1291
SER122B	SEL122B			.750	.750	.500	4.5	1.000	.138	1.000			
SER123B	SEL123B			.750	.750	.750	4.5	2.000	.210	1.125			
SER163D	SEL163D	SG-3R	SG-3L	1.000	1.000	.750	6.0	2.000	.210	1.250	TF72	TF73	ST-1297
SER203D	SEL203D			1.250	1.250	.750	6.0	2.000	.210	1.500			

Note: Right-hand boring bars use left-hand inserts. Left-hand boring bars use right-hand inserts.



■ SUMINOTCH GROOVING BORING BARS

A-SE Series											
Sumitomo Cat. No.		Gage Insert		D	C	F	Min. Bore	A	Right Hand Clamp	Left Hand Clamp	Clamp Screw
Right Hand	Left Hand	R.H.	L.H.								
A08-SER2	A08-SEL2	SG-2R	SG-2L	.500	8.000	.437	0.730	1/4-18 NPT	TF-74	TF-75	S-310
A10-SER2	A10-SEL2	SG-2R	SG-2L	.625	10.000	.500	1.000	1/4-18 NPT	TF-74	TF-75	S-310
A12-SER2	A12-SEL2	SG-2R	SG-2L	.750	10.000	.562	1.125	1/4-18 NPT	TF-74	TF-75	S-310
A16-SER2	A16-SEL2	SG-2R	SG-2L	1.000	12.000	.688	1.375	1/4-18 NPT	TF-74	TF-75	S-310
A16-SER3	A16-SEL3	SG-3R	SG-3L	1.000	12.000	.688	1.375	1/4-18 NPT	TF72	TF-73	S-412
A20-SER3	A20-SEL3	SG-3R	SG-3L	1.250	14.000	.875	1.750	1/4-18 NPT	TF72	TF-73	S-412
A24-SER3	A24-SEL3	SG-3R	SG-3L	1.500	14.000	1.000	2.000	1/4-18 NPT	TF72	TF-73	S-412

Note: Right-hand boring bars use left-hand inserts. Left-hand boring bars use right-hand inserts.

■ SUMINOTCH GROOVING INSERTS

■ RECOMMENDED RUNNING CONDITIONS

Material		Speed (SFM)	Feed Rate (in/rev)
Steels	free-machining carbon alloys	450-750	.004 - .012
	plain carbon steels	400-700	
	alloy steels 190-330HB	400-700	
	alloy steels 330-450HB	350-600	
Stainless Steels	martensitic/ferritic stainless steel	250-650	.004 - .009
	austenitic stainless steel	175-700	
Cast Iron	gray cast iron 190-330HB	400-700	.004 - .015
	gray cast iron 330-450HB	350-600	
	alloy/ductile irons	250-650	
	high temp alloys 200-260HB	60-250	
High Temperature Alloys	high temp alloys 260-450HB	30-175	.003 - .008
	titanium alloys Ti 6Al-4V	90-250	
	free-machining aluminum alloys	600-2500	
Non-Ferrous Materials	copper/zinc/brass	300-900	.004 - .012
	non-metallics	350-1200	

- USA Stocked Item
- ★ Worldwide Warehouse Item
- ▲ USA Limited Availability Item

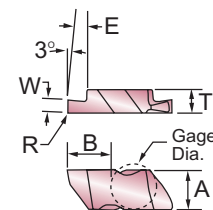

Left				Dimensions (in)							Right			
SG	Coated	CBN		W ±.001	R	E ±.001	T	A	B	Gage Dia.	SG	Coated	CBN	
	EH520V	BN250	BN350									EH520V	BN250	BN350
SG-2031L	●			.031	.002/.005	.050	.150	.219	.2700	.1875	SG-2031R	●		
SG-2041L	●			.041	.002/.005	.050					SG-2041R	●		
SG-2047L	●			.047	.002/.005	.050					SG-2047R	●		
SG-2058L	●			.058	.005/.010	.050					SG-2058R	●		
SG-2062L	●			.062	.005/.010	.110					SG-2062R	●		
SG-2094L	●			.094	.005/.010	.110					SG-2094R	●		
SG-2125L	●			.125	.005/.010	.110					SG-2125R	●		
SG-3047L	●			.047	.005/.010	.120	.195	.344	.4050	.3750	SG-3047R	●	●	●
SG-3062L	●	●	●	.062	.005/.010	.120					SG-3062R	●	●	●
SG-3072L	●			.072	.005/.010	.120					SG-3072R	●		
SG-3088L	●			.088	.005/.010	.180					SG-3088R	●		
SG-3094L	●	●	●	.094	.005/.010	.180					SG-3094R	●	●	●
SG-3097L	●			.097	.005/.010	.180					SG-3097R	●		
SG-3105L	●			.105	.005/.010	.180					SG-3105R	●		
SG-3110L	●			.110	.005/.010	.180					SG-3110R	●		
SG-3122L	●			.122	.005/.010	.180					SG-3122R	●		
SG-3125L	●	●	●	.125	.005/.010	.180					SG-3125R	●	●	●
SG-3142L	●			.142	.005/.010	.180					SG-3142R	●		
SG-3156L	●			.156	.005/.010	.180					SG-3156R	●		
SG-3178L	●			.178	.005/.010	.180					SG-3178R	●		
SG-3185L	●			.185	.020/.025	.180					SG-3185R	●		
SG-3189L	●			.189	.020/.025	.180	SG-3189R	●						

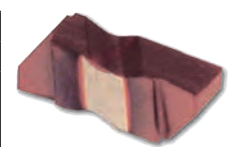

SUMINOTCH GROOVING INSERTS- Cont'd

Left		Dimensions (in)							Right	
SG-CB	Coated	W ±.001	R	E ±.001	T	A	B	Gage Dia.	SG-CB	Coated
	EH520V									EH520V
SG-2047L-CB	•	.047	.002/.005	.050	.150	.219	.2700	.1875	SG-2047R-CB	•
SG-2062L-CB	•	.062	.005/.010	.110					SG-2062R-CB	•
SG-2078L-CB	•	.078	.005/.010	.110					SG-2078R-CB	•
SG-2094L-CB	•	.094	.005/.010	.110					SG-2094R-CB	•
SG-2125L-CB	•	.125	.005/.010	.110					SG-2125R-CB	•
SG-3047L-CB	•	.047	.005/.010	.075	.195	.344	.4050	.3750	SG-3047R-CB	•
SG-3062L-CB	•	.062	.005/.010	.094					SG-3062R-CB	•
SG-3072L-CB	•	.072	.005/.010	.094					SG-3072R-CB	•
SG-3078L-CB	•	.078	.005/.010	.094					SG-3078R-CB	•
SG-3088L-CB	•	.088	.005/.010	.150					SG-3088R-CB	•
SG-3094L-CB	•	.094	.005/.010	.150					SG-3094R-CB	•
SG-3125L-CB	•	.125	.020/.025	.150					SG-3125R-CB	•
SG-3189L-CB	•	.189	.020/.025	.150					SG-3189R-CB	•

• = USA Stocked Item

Internal Grooving

SGIT
Internal Grooving

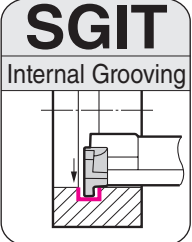



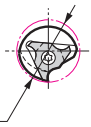

ϕD_m Min. Bore

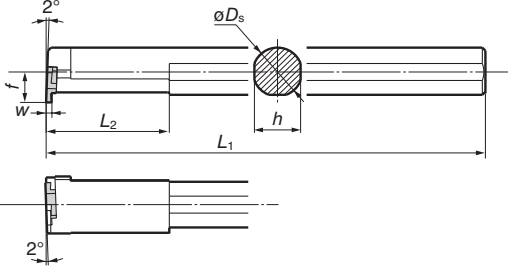

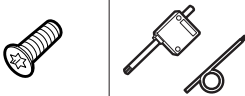

■ Holders

Cat. No.	Stock	Dimensions (mm)					Min. Bore (mm)	Grooving Width (mm) w	Max. Grooving Depth (mm)	Gage Insert	Screw	Wrench
		ϕD_s	h	L1	f	L2						
SGIT R08	★	8	7.0	125	5.0	20	10.0	0.50 to 2.00	0.8*	GITL3□□□	BFTX02506NS	RT08
SGIT R10	★	10	9.0	150	6.0	25	12.0					
SGIT R12	★	12	11.0	180	7.0	30	14.0	1.00 to 2.00	1.8	GITL5□□□	BFTX0307NS	RT10
SGIT R14	★	14	13.0	180	8.0	35	16.0					
SGIT R16	★	16	15.0	200	10.0	40	20.0	1.50 to 2.00	2.8	GITL6□□□		
SGIT R20	★	20	19.0	200	12.0	40	25.0					

■ Inserts

*Maximum grooving depth is 0.5mm when GITL3050 is set.

Cat. No.	Coated Carbide	Dimensions (mm)				Holder
	ACZ150	w	a	r _E	ϕd	
GIT L3050	★	0.50	1.2	0.05	5.56	SGIT R08 SGIT R10
GIT L3065	★	0.65	1.2	0.05	5.56	
GIT L3075	★	0.75	1.2	0.05	5.56	
GIT L3100	★	1.00	1.2	0.05	5.56	
GIT L3125	★	1.25	1.2	0.20	5.56	
GIT L3145	★	1.45	1.2	0.20	5.56	
GIT L3150	★	1.50	1.2	0.05	5.56	
GIT L3200	★	2.00	1.2	0.10	5.56	SGIT R12 SGIT R14
GIT L5100	★	1.00	2.2	0.05	7.94	
GIT L5145	★	1.45	2.2	0.20	7.94	
GIT L5150	★	1.50	2.2	0.05	7.94	
GIT L5175	★	1.75	2.2	0.20	7.94	
GIT L5200	★	2.00	2.2	0.10	7.94	SGIT R16 SGIT R20
GIT L6150	★	1.50	3.2	0.20	9.525	
GIT L6175	★	1.75	3.2	0.20	9.525	
GIT L6200	★	2.00	3.2	0.20	9.525	

★ Worldwide Warehouse Item



Threading, Grooving, & Cut-Off Holders



■ **Features & Benefits**

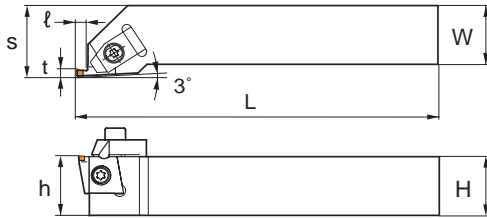

- New double clamping system provides reliable grooving of hardened steel
- 80° tangentially mounted CGA style insert for improved rigidity
- Wide range of widths and grades for continuous and interrupted grooving operations
- New special coated CBN grade BNC30G extends tool life of insert

GWB Series

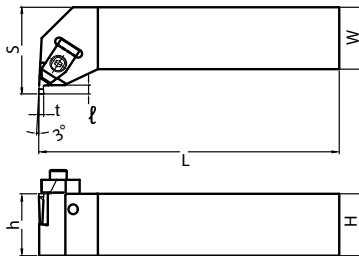

GWBS 90° Series

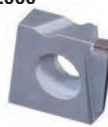
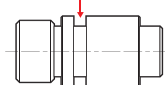

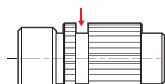
Grade	Application	Features	Hv (GPa)	TRS (GPa)
BN2000 	Continuous grooving 	General purpose grade with good wear resistance	31-34	1.0-1.1
BNC30G 	Interrupted grooving 	Tough CBN substrate and special coating with high wear and peeling resistance	33-35	1.1-1.2

■ **GWB(S) SERIES HOLDERS**

Sumitomo Cat. No.	Stk.	H in (mm)	W in (mm)	h in (mm)	s in (mm)	t in (mm)	l in (mm)	L in (mm)	Insert (See p. 134 for CGA availability & technical information)
GWBR 165D4	●	1.0 (25.4)	1.0 (25.4)	1.0 (25.4)	1.181 (30.0)	.059 < t ≤ .079 (1.5 < t ≤ 2.0)	.138 (3.5)	6.0 (152.4)	CGA R/L 1504□□ CGA R/L 4□□□
GWBL 165D4						.079 < t ≤ .118 (2.0 < t ≤ 3.0)	.177 (4.5)	6.039 (153.4)	
						.118 < t ≤ .177 (3.0 < t ≤ 4.5)	.197 (5.0)		
GWBR 165D6	●	1.0 (25.4)	1.0 (25.4)	1.0 (25.4)	1.181 (30.0)	.177 < t ≤ .236 (4.5 < t ≤ 6.0)	.197 (5.0)	6.039 (153.4)	CGA R/L 1506□□ CGA R/L 6□□□
GWBL 165D6									
GWBR 2525-45	★	.984 (25.0)	.984 (25.0)	.984 (25.0)	1.181 (30.0)	.059 < t ≤ .079 (1.5 < t ≤ 2.0)	.138 (3.5)	6.0 (152.4)	CGA R/L 1504□□ CGA R/L 4□□□
GWBL 2525-45						.079 < t ≤ .118 (2.0 < t ≤ 3.0)	.177 (4.5)	6.039 (153.4)	
						.118 < t ≤ .177 (3.0 < t ≤ 4.5)	.197 (5.0)		
GWBR 2525-60	★	.984 (25.0)	.984 (25.0)	.984 (25.0)	1.181 (30.0)	.177 < t ≤ .236 (4.5 < t ≤ 6.0)	.197 (5.0)	6.039 (153.4)	CGA R/L 1506□□ CGA R/L 6□□□
GWBL 2525-60									
GWBSR125D4	●	.750 (19.05)	.750 (19.05)	.750 (19.05)	.880 (22.35)	.059 < t ≤ .079 (1.5 < t ≤ 2.0)	.138 (3.5)	6.0 (152.4)	CGA R/L 1504□□ CGA R/L 4□□□
GWBSL125D4						.079 < t ≤ .118 (2.0 < t ≤ 3.0)	.177 (4.5)	6.0 (152.4)	
						.118 < t ≤ .177 (3.0 < t ≤ 4.5)	.197 (5.0)		
GWBSR165D4	●	1.0 (25.4)	1.0 (25.4)	1.0 (25.4)	1.167 (29.64)	.059 < t ≤ .079 (1.5 < t ≤ 2.0)	.138 (3.5)	6.0 (152.4)	CGA R/L 1504□□ CGA R/L 4□□□
GWBSL165D4						.079 < t ≤ .118 (2.0 < t ≤ 3.0)	.177 (4.5)	6.0 (152.4)	
						.118 < t ≤ .177 (3.0 < t ≤ 4.5)	.197 (5.0)		
GWBSR165D6	●	1.0 (25.4)	1.0 (25.4)	1.0 (25.4)	1.167 (29.64)	.177 < t ≤ .236 (4.5 < t ≤ 6.0)	.197 (5.0)	6.0 (152.4)	CGA R/L 1506□□ CGA R/L 6□□□
GWBSL165D6									
GWBSR205D4	●	1.25 (31.75)	1.25 (31.75)	1.25 (31.75)	1.75 (44.45)	.059 < t ≤ .079 (1.5 < t ≤ 2.0)	.138 (3.5)	6.0 (152.4)	CGA R/L 1504□□ CGA R/L 4□□□
GWBSL205D4						.079 < t ≤ .118 (2.0 < t ≤ 3.0)	.177 (4.5)	6.0 (152.4)	
						.118 < t ≤ .177 (3.0 < t ≤ 4.5)	.197 (5.0)		

● = USA Stocked Item
★ = Worldwide Warehouse Item



BNC30G



BN2000

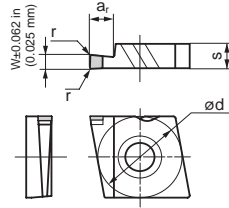

■ INSERTS

CGA	Coated	Uncoated	Dimensions							
	BNC30G	BN2000	W ± .001 in. ± .025 (mm)	a _r in (mm)	r in (mm)	ød in (mm)	s in (mm)			
CGAR4062	●	●	.062 (1.575)	.1378 (3.5)	.0078 (.2)	.625 (15.875)	.1875 (4.76)			
CGAL4062										
CGAR4094	●	●	.094 (2.388)	.1575 (4.0)						
CGAL4094										
CGAR4125	●	●	.125 (3.175)	.1969 (5.0)			.0078 (.2)	.625 (15.875)	.25 (6.35)	
CGAL4125										
CGAR6189	●	●	.189 (4.801)							
CGAL6189										
CGAR1504150	●		.0591 (1.5)	.1378 (3.5)	.0078 (.2)	.625 (15.875)			.1875 (4.76)	
CGAL1504150		●								
CGAR1504200	●	●	.0787 (2.0)	.1575 (4.0)						
CGAL1504200										
CGAR1504250	●	●	.0984 (2.5)	.1969 (5.0)			.0078 (.2)	.625 (15.875)		.25 (6.35)
CGAL1504250										
CGAR1504300	●	●	.1181 (3.0)	.1378 (3.5)						
CGAL1504300										
CGAR1504350	●		.1378 (3.5)	.1575 (4.0)						
CGAL1504350										
CGAR1504400	●	●	.1575 (4.0)	.1969 (5.0)	.0078 (.2)	.625 (15.875)	.25 (6.35)			
CGAL1504400										
CGAR1504450	●		.1772 (4.5)	.1378 (3.5)						
CGAL1504450										
CGAR1506500	●	●	.1969 (5.0)	.1575 (4.0)						
CGAL1506500										
CGAR1506550	●		.2165 (5.5)	.1969 (5.0)	.0078 (.2)	.625 (15.875)	.25 (6.35)			
CGAL1506550										
CGAR1506600	●	●	.2362 (6.0)							
CGAL1506600										

● USA Stocked Item

■ RECOMMENDED CUTTING CONDITIONS

For hardened steel:	
Cutting Speed	260 - 400 sfm (80 - 120 m/min)
Feed Rate	.0016 - .0032 ipr (.04 - .08 mm/rev)
Coolant	Continuous cut: dry or wet Interrupted cut: dry
NOTE: To avoid thermal cracking of cutting edge during interrupted cutting applications, please ensure workpiece remains dry.	

■ HARDWARE

Clamp	Clamp Screw	Insert Screw	Spring	Wrench
TF-72 (Right hand)	BX0520T	BFTX 0511N	GSP06	TRX20
TF-73 (Left hand)				



LTER Series

For External Threading



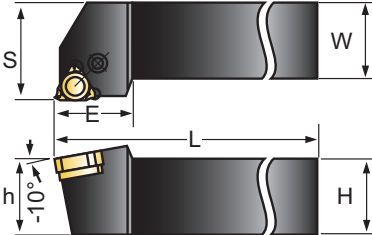





LAYDOWN EXTERNAL THREADING INSERTS:

TME____R
TUE____R
TWE____R



These figures show right hand tools.

Sumitomo Cat. No.	STKD.	Dimensions						Lever Pin	Clamp Bolt	Shim	Shim Pin	Wrench
		H	W	h	S	L	E					
LTER 123C	•	.750	.750	.750	1.000	5.000	1.000	LCL3S	LCS3TE	LSTE31-0	LSP3	LH025
LTER 163D	•	1.000	1.000	1.000	1.250	6.000	1.000					

• = USA Stocked Item

STIR Series

For Internal Threading

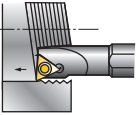

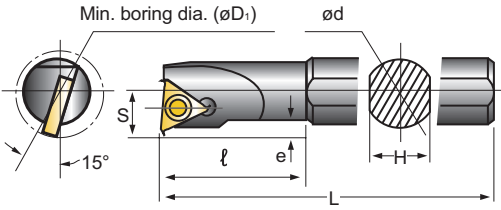

LAYDOWN INTERNAL THREADING INSERTS:

TMI____R
TNPTI____R

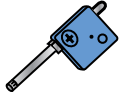

Sumitomo Cat. No.	STKD.	Dimensions							Screw	Wrench
		ø d	H	L	Min.Bore øD1	S	e	ℓ		
STIR 103	•	.625	.590	6.000	.750	.406	.006	1.378	BFTX03508	TRX10
STIR 123	•	.750	.670	7.000	1.000	.492	.006	1.575	BFTX03508	TRX10
STIR 163	•	1.000	.905	8.000	1.150	.600	.006	1.500	BFTX03508	TRX10
STIR 203	•	1.250	1.142	10.000	1.400	.724	.006	1.500	BFTX03508	TRX10
STIR 243	•	1.500	1.378	12.000	1.700	.897	.006	1.500	BFTX03508	TRX10

• = USA Stocked Item

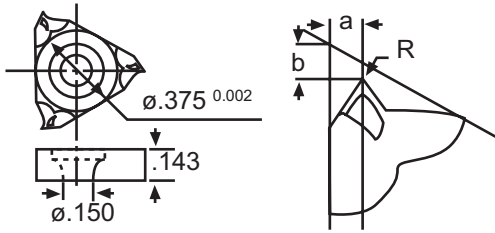

- USA Stocked Item
- ★ Worldwide Warehouse Item
- ▲ USA Limited Availability Item

EXTERNAL LAYDOWN - Full Profile (ISO Metric)

Sumitomo Catalog Number	Pitch (mm)	Threads/in	Stock Grade				R	Included Angle θ°	a	b
			Uncoated	Coated		Cermet				
			A30	EH20Z	AC225	T130A				
TME100R	1.00	-		▲	●		.0050	60	.031	.047
TME125R	1.25	-	▲	▲	●	.0067				
TME150R	1.50	-	●	▲	●	.0080				
TME175R	1.75	-			●	.0094				
TME200R	2.00	-	▲	▲	●	.0106				
TME250R	2.50	-	▲	▲	●	.0140				
TME300R	3.00	-		▲	●	.0165				

Full Profile (Inch)

Sumitomo Catalog Number	Pitch (mm)	Threads/in	Stock Grade					R	Included Angle θ°	a	b
			Uncoated	Coated		Cermet					
			A30	EH20Z	AC225	T1500A	T130A				
TUE24R	-	24	▲		●			.0047	60	.031	.047
TUE20R	-	20	●	▲	●		.0059				
TUE18R	-	18	●	▲	●		.0067				
TUE16R	-	16	●	▲	●		.0079				
TUE14R	-	14	●	▲	●	●	.0091				
TUE12R	-	12	●	●	●	●	.0110				
TUE08R	-	8		●	●		.0169				

Partial Profile (60°)

Sumitomo Catalog Number	Pitch (mm)	Threads/in	Stock Grade				R	Included Angle θ°	a	b
			Uncoated	Coated		Cermet				
			A30	EH20Z	AC225	T130A				
TME1020R	1.0 ~ 2.0	24 ~ 12	●	▲	●	●	.005	60	.043	.047
TME1530R	1.50 ~ 3.00	16 ~ 8	●	▲	●	●	.008			

Partial Profile (55°)

Sumitomo Catalog Number	Inch	Threads/in	Stock Grade			R	Included Angle θ°	a	b
			Uncoated	Coated	Cermet				
			A30	AC225	T130A				
TWE1410R	-	14 ~ 10	▲	●	●	.009	55	.055	.047
TWE2416R	-	24 ~ 16	▲	●	●	.005			



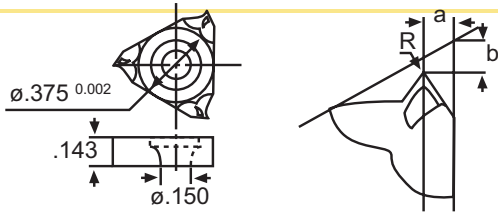

- USA Stocked Item
- ★ Worldwide Warehouse Item
- ▲ USA Limited Availability Item

INTERNAL LAYDOWN - Full Profile (ISO Metric)

Sumitomo Catalog Number	Pitch (mm)	Threads/in	Stock Grade				R	Included Angle θ°	a	b
			Uncoated	Coated		Cermet				
			A30	EH20Z	AC225	T130A				
TMI100R	1.00	-	●	▲	●	▲	.0024	60	.031	.047
TMI125R	1.25	-	▲		▲		.0030			
TMI150R	1.50	-			●	●	.0035			
TMI175R	1.75	-	▲	▲	●		.0043			
TMI200R	2.00	-	●		●	●	.0050			
TMI250R	2.50	-	▲		▲		.0063			
TMI300R	3.00	-		▲	●		.0080			

Partial Profile (60°)

Sumitomo Catalog Number	Pitch (mm)	Threads/in	Stock Grade					R	Included Angle θ°	a	b
			Uncoated	Coated		Cermet					
			A30	EH20Z	AC225	T1500A	T130A				
TMI1020R	1.0 ~ 2.0	24 ~ 12	●	▲	●	●	●	.0024	60	.039	.047
TMI1530R	1.50 ~ 3.00	16 ~ 8	●	●	●	●	●	.0035			

Partial Profile (NPT)

Sumitomo Catalog Number	Pitch (mm)	Threads/in	Stock Grade			R	Included Angle θ°	a	b
			Uncoated	Coated	Cermet				
			A30	EH20Z	T130A				
TNPT115R	-	11.5	▲	▲	●	.0004	60	.059	.043

THREADING INSERTS FOR BNGG HOLDERS

Sumitomo Catalog Number	Pitch (mm)	Threads/in	Stock Grade		R	Included Angle θ°	a	b
			CBN					
			BN250	BN600				
BNTT1020R	1.0 ~ 2.0	-	●	▲	.0024	60	.039	.047
BNTT1530R	1.50 ~ 3.00	-	●		.0035			

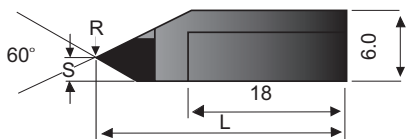

Solid Carbide • Solid Quality • Solid Performance

Because of the solid tungsten carbide support blade, Sumitomo cut-off tools are able to perform at depths 40% greater than any tools now available. Tungsten carbide is more rigid than steel so even in long overhang applications, bending, vibration and movement at the cutting edge are drastically reduced.

The solid carbide support blades fit in many existing cut-off tool blocks.

The unique positive rake inserts are available in neutral, right hand, and left hand styles. The insert design collapses the width of the chip, breaks

it and facilitates chip flow away from the cut, thus welding and wear on the insert corners are greatly reduced, and coolant is easier to direct.

Operating at high speeds and feeds is possible because of longer tool life, and down-time for chip removal is drastically reduced.

Safety is enhanced because long, stringy chips are avoided.

Note: Sumitomo Inserts fit only Sumitomo Blades.

Maximum Cut-Off Diameter

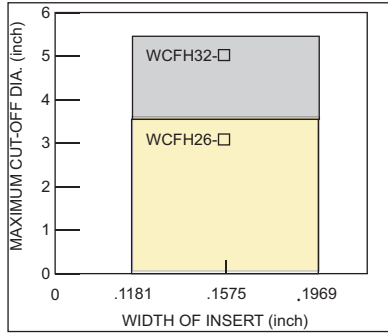

Grade Application Range

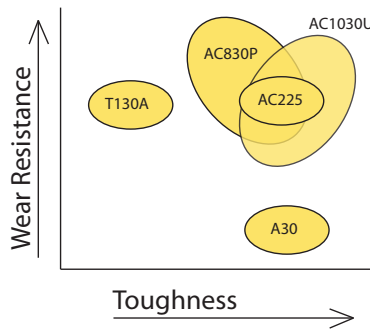

Chipbreaker Range

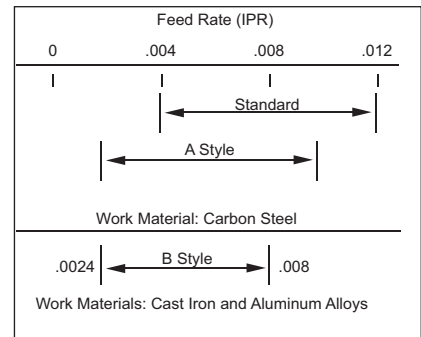

Inserts Application

Grade	C.B. Style	Application	Feature
AC830P	Standard	Heavy feed in steel (.0032-.012 ipr)	Coated insert with excellent wear resistance. Standard chipbreaker for low cutting force applications.
	GG	general steel	general purpose, neutral chipbreaker
AC1030U	GF	Hard-to-cut metals	for low cutting force, neutral chipbreaker
	CF	Hard-to-cut metals	for low cutting force, handed chipbreaker
AC225	A	Light feed in steel (.0016-.010 ipr)	Coated insert with excellent toughness. A style chipbreaker with good chip control.
		Carbon steel, stainless steel	
T130A	A	Light feed in steel (.0012-.0061 ipr)	Cermet inserts produce excellent surface finish.
A30N	A	Slow speed and feed in steel	Equivalent to C5, C6 carbide.
G10E	A	For exotic materials	C2 carbide for exotic materials.
	B	For cast iron and aluminum alloy	C2 carbide with a sharp cutting edge.

Recommended Cutting Conditions

Part Material		Grade					
		AC830P	AC1030U	AC225	T1500A/ T1200A	A30	G10E
P Steel	General Steel	260-660	160-660	260-660	260-660	150-400	-
	Soft Steel	330-750	160-750	330-750	330-750	230-500	-
	Die Steel	200-500	160-500	200-500	200-500	150-400	-
M Stainless Steels		230-500	160-500	200-500	-	230-450	-
K Cast Irons		-	160-660	-	-	-	160-400
N Non-ferrous Metal		-	-	-	-	-	660-1650

CAUTION

1. Do not use AC225 for light feed rate applications (Feed rate should be at least .004 ipr)
2. Use AC225 for stainless steel.
3. Use A style chipbreaker for low carbon steel.
4. Use coolant

Breaker & Type	Width (mm)	Feed f (IPR)										
		Neutral					Handed					
		GG	GF	none	T	A	B	none	CF	T	A	B
Width (mm)	2	.002-.008	.0012-.005	-	.0012-.004	.0012-.005	-	-	-	.0012-.004	-	-
	3	.003-.010	.0015-.006	.003-.010	-	.0015-.006	.002-.006	.003-.010	.002-.005	-	.0015-.006	.002-.006
	4	.004-.012	.002-.007	.004-.012	-	.002-.007	.002-.007	.004-.012	.002-.005	-	.002-.007	.002-.007
	5	.004-.014	.002-.008	.004-.012	-	.002-.008	.0025-.008	.004-.012	-	-	-	.0025-.008



Threading, Grooving, & Cut-Off Holders

WCFS Series HOLDERS

For Cutting Off

HARDENED STEEL HOLDER

These figures show right hand tools.

Sumitomo Cat. No.	STKD.		Dimensions						Support Blade	Insert	Extractor	Clamp Screw	Wrench
	R	L	W	B	L	S	H	T					
WCFSR/L-063-3	•	•	.625	.625	4.000	.740	.625	.1181	WCFH17-3	WCF□3□			
WCFSR/L-075-3	•	•	.750	.750	4.500	.870	.750	.1181	WCFH17-3	WCF□3□			
WCFSR/L-075-4	•	•	.750	.750	4.500	.910	.750	.1575	WCFH17-4	WCF□4□			
WCFSR/L-075-5	•	•	.750	.750	4.500	.950	.750	.1969	WCFH17-5	WCF□5□	SL-1	BX0622	LH050
WCFSR/L-100-3	•	•	1.000	1.000	6.000	1.120	1.000	.1181	WCFH17-3	WCF□3□			
WCFSR/L-100-4	•	•	1.000	1.000	6.000	1.160	1.000	.1575	WCFH17-4	WCF□4□			
WCFSR/L-100-5	•	•	1.000	1.000	6.000	1.200	1.000	.1969	WCFH17-5	WCF□5□			

BLADES

SOLID CARBIDE BLADE

Sumitomo Cat. No.	STOCK	Dimensions	
		W	B
WCFH17-3	•	.1181	.094
WCFH17-4	•	.1575	.134
WCFH17-5	•	.1969	.169

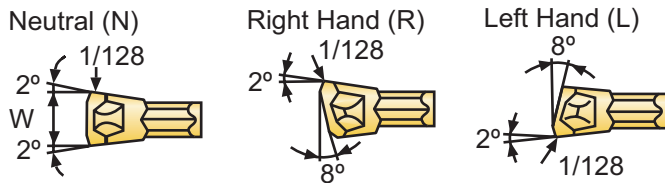

• = USA stocked item
 ▲ = USA limited availability item

WCF□○○□ General Steel			WCF□○○A Hard-to-cut metals Slow feed			WCF□○○GF Hard-to-cut metals Slow feed			WCF□○○CF Hard-to-cut metals Slow feed			WCF□○○B Cast iron Aluminum alloy		
Catalog Number	Coated AC830P	W	Catalog Number	Coated AC1030U	Coated AC225	Cermet T130A	Uncoated A30 G10E		W	Catalog Number	Uncoated G10E	W		
WCFN2T	•	.0787	WCFN2-GF	•					.0787					
WCFR2T	•		WCFN3A		•	•	•	•	.1181	WCFN3B	•	.1181		
WCFN2-GG	•		WCFR3A		•	•	•	▲		WCFR3B	•			
WCFN3	•	WCFL3A		•	•	•	•	WCFL3B		•				
WCFR3	•	.1575	WCFN3-GF	•				.1575	WCFN4B	•	.1575			
WCFL3	•		WCFR3-CF	•					WCFR4B	•				
WCFN3-GG	•		WCFL3-CF	•					WCFL4B	•				
WCFN4	•	.1969	WCFN4A		•	•	•	.1969	WCFN5B	•	.1969			
WCFR4	•		WCFR4A		•				WCFR5B	•				
WCFL4	•		WCFL4A		•				WCFL5B	•				
WCFN4-GG	•		WCFN4-GF	•										
WCFN5	•		WCFR4-CF	•										
WCFR5	•		WCFL4-CF	•										
WCFL5	•		WCFN5A		•	•	•							
WCFN5-GG	•		WCFR5A		•									
			WCFL5A		•									
			WCFN5-GF	•										



Threading, Grooving, & Cut-Off Holders

Sumitomo Cat. No.		STKD.	Dimensions					Tool Block		Insert	Extractor		
		R	W	B	H ₁	H ₂	L ₁	L ₂	Max. Cut-Off Dia.				
WCFH26-3	•	.1181	.0945							SBN063-26	SBU075-26	WCF□3(A, B)	SL-1
WCFH26-4	•	.1575	.1339	.844	1.031	4.344	4.281	3.150		SBN075-26		WCF□4(A, B)	
WCFH26-5	•	.1969	.1693									WCF□5(A, B)	
WCFH32-3	•	.1181	.0945							SBN100-32	SBU075-32	WCF□3(A, B)	
WCFH32-4	•	.1575	.1339	.984	1.250	5.906	5.844	5.500		SBN125-32	SBU100-32	WCF□4(A, B)	
WCFH32-5	•	.1969	.1693									WCF□5(A, B)	

• = USA Stocked Item

Sumitomo Cat. No.	Dimensions							Clamp	Clamp Screw	Wrench
	L	h ₁	h ₂	h ₃	H	B ₁	B ₂			
SBN063-26	3.000	.625	.625	.500	1.719	.625	1.328	BWS-30	WB8-20	LH040
SBN075-26	3.156	.750	.750	.375	1.719	.750	1.469			
SBN100-32	4.500	1.000	1.000	.3125	2.000	.8125	1.531			

Sumitomo Cat. No.	Dimensions							Wedge Clamp	Clamp Screw	Wrench
	L	H	h ₁	h ₂	h ₃	B ₁	B ₂			
SBU075-26	3.156	1.781	.750	.750	.4375	.750	1.719	BCS15		
SBU075-32	4.000	2.000	.750	.750	.531	.781	1.719	BCS20	BX0622	LH050
SBU100-32	4.344	2.000	1.000	1.000	.344	.781	1.719	BCS25		

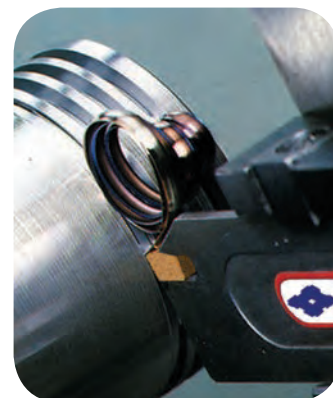

STFH Series Sumi-Grip Jr.

SUPPORT BLADES

For Cutting Off

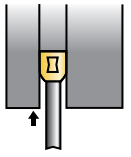

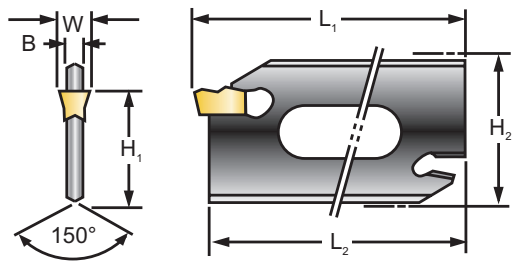

HARDENED STEEL BLADE

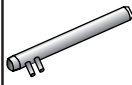

Sumitomo Cat. No.	STKD.	Dimensions								Tool Block		Insert	Wrench
	R	W	B	H ₁	H ₂	L ₁	L ₂	Max. Cut-Off Dia.					
STFH26-2	●	.0800	.0630	.8425	1.024	4.291	4.252	1.580	SBN063-26	SBU075-26	WCF□2T	SL-4	
STFH26-3	●	.1200	.0945	.8425	1.024	4.291	4.252	2.760	SBN075-26	SBU075-26	WCF□3□		
STFH32-2	●	.0800	.0630	.9843	1.260	5.866	5.827	1.580	SBN100-32	SBU075-32	WCF□2T		
STFH32-3	●	.1200	.0945	.9843	1.260	5.866	5.827	3.940	SBN125-32	SBU100-32	WCF□3□		

● = USA Stocked Item

STFS Series Sumi-Grip Jr.

TOOL HOLDERS

For Cutting Off

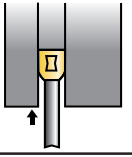

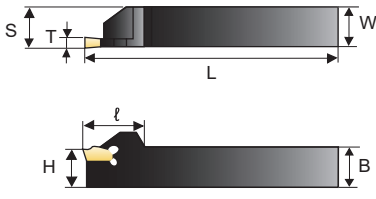

HARDENED STEEL HOLDER

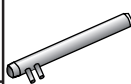

These figures show right hand tools.

Sumitomo Cat. No.	STKD.		Dimensions							Max. Cut-Off Dia.	Insert	Wrench
	R	L	W	B	L	S	H	T				
STFSR/L-063-2	●	●	.625	.625	4.000	.625	.625	.0800	.650	WCF□2T	SL-4	
STFSR/L-075-2	●	●	.750	.750	5.000	.750	.750	.0800	.840	WCF□2T		
STFSR/L-063-3	●	●	.625	.625	4.000	.625	.625	.1200	.750	WCF□3□		
STFSR/L-075-3	●	●	.750	.750	5.000	.750	.750	.1200	1.000	WCF□3□		
STFSR/L-100-3	●	●	1.000	1.000	6.000	1.000	1.000	.1200	1.000	WCF□3□		

Sumi-Grip Jr. is only available in steel blades and holders.

● USA Stocked Item



Threading, Grooving, & Cut-Off Holders

BNGG Series Grooving

For External Grooving

Sumitomo Cat. No.	STK		Dimensions							
	R	L	W	H	L	S	D	h	ℓ	
BNGGR/L160	•		1	1	6	1.25	.281	1	.2	

- For use in hard grooving with BNGNT type inserts.
- Extremely rigid design.
- Solves the chipping problems associated with vibration.
- **ANVIL SOLD SEPARATELY.**

BNGG Series Threading

For External Threading

Sumitomo Cat. No.	STK		Dimensions							
	R	L	W	H	L	S	D	h	ℓ	
BNGGR/L160	•		1	1	6	1.25	.281	1	.2	

- For use in hard threading with BNTT inserts.
- May apply various threading widths.
- **ANVIL SOLD SEPARATELY.**

Grooving Inserts

Insert	Grade					
	BN250		BN350		BN500	
	R	L	R	L	R	L
BNGNT0200R/L	•	•	•			
BNGNT0250R/L	•	•				
BNGNT0300R/L	•	•	•			
BNGNT0400R/L	•	•	•			
BNGNT0500R/L	•	•				
BNGNT0600R/L	•	•				

Note: BNGNT inserts can be made in special widths per individual requirements. When using a special width BNGNT insert, the anvil must be altered as well. Please contact the Engineering Department for more information.

Threading Inserts

Insert	Grade	
	BN250	
	R	L
BNTT1020R/L	•	
BNTT1530R/L	•	

* Threading Anvil

BNGSR/LTT

* Grooving Anvil

BNGSR/L200
BNGSR/L250
BNGSR/L300
BNGSR/L400
BNGSR/L500
BNGSR/L600

* Grooving Anvil Additional Widths

BNGSR/L150
BNGSR/L350
BNGSR/L450
BNGSR/L550

Hardware for Holders

Holder Cat. No.	Clamp	Adjust. Screw	Spring	Screws	Wrenches
BNGGR/L160	BNGCR/L	FMJ	GSP06	(Clamp Screw) BX0615 (Anvil Screw) BX0414	(Clamp Wrench) LH050 (Anvil Wrench) LH030

Note: Holders for threading or grooving are identical, even though they have different part numbers. You may substitute one holder for the other and all hardware items are interchangeable.

* Holder and anvil assembly required

* Anvil sold separately.



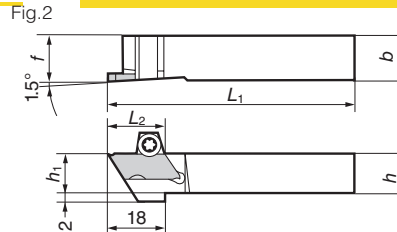
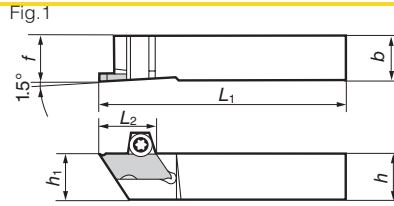
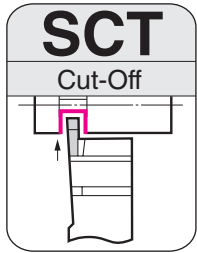

■ Spare Parts

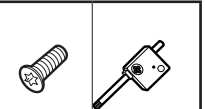

■ Holders Right Hand (R) & Left Hand (L)

Above figures show right hand tools.

Cat. No.	Stock	Dimensions (mm)						Gage Insert	Fig.	Screw	Wrench
		h	b	L1	f	h1	L2				
SCT R08	●	.500	.500	6.0	.500	.500	.591	CT R12○○○○(-NB)	1	BFTX0410T8L	TRX08
SCT R10	●	.625	.625	6.0	.625	.625	.591				
SCT R12	●	.750	.750	6.0	.750	.750	.591				
SCT R1010	★	10	10	120	10	10	15	CT R05○○○○(-NB) CT R12○○○○(-NB)	2		
SCT R1212	★	12	12	120	12	12	15				
SCT R1616	★	16	16	120	16	16	15				
SCT R1010-16	★	10	10	120	10	10	18	CT R16○○○○(-NB)	1		
SCT R1212-16	★	12	12	120	12	12	18				
SCT R1616-16	★	16	16	120	16	16	18				
SCT L08	●	.500	.500	6.0	.500	.500	.591	CT R12○○○○(-NB)	1	BFTX0410T8R	TRX08
SCT L10	●	.625	.625	6.0	.625	.625	.591				
SCT L12	●	.750	.750	6.0	.750	.750	.591				
SCT L1010	★	10	10	120	10	10	15	CT L05○○○○(-NB) CT L12○○○○(-NB)	2		
SCT L1212	★	12	12	120	12	12	15				
SCT L1616	★	16	16	120	16	16	15				
SCT L1010-16	★	10	10	120	10	10	18	CT L16○○○○(-NB)	1		
SCT L1212-16	★	12	12	120	12	12	18				
SCT L1616-16	★	16	16	120	16	16	18				

●: USA Stocked Item

★: Worldwide Warehouse Item

■ Characteristics

- **New clamping system**
New clamping system makes it possible to change corners by only loosening the screw from the back.
- **High quality surface finish**
Excellent chip removal with good surface finish even at the centre of the end face.
- **Stable and long tool life**
PVD-coated grade ACZ530U provides stability and longer tool life.

● Design

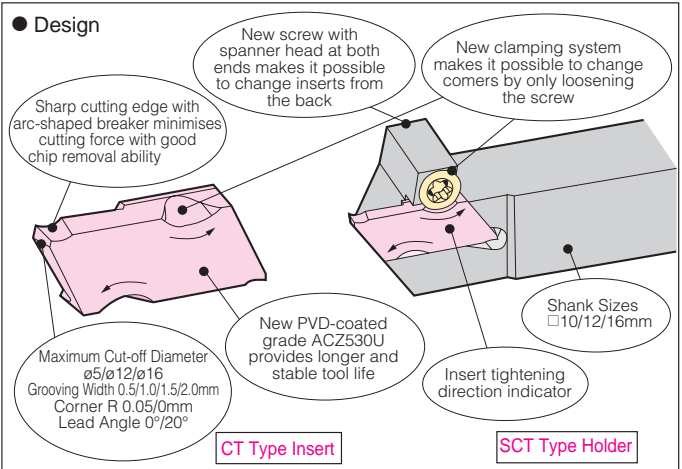

■ Comparison Test

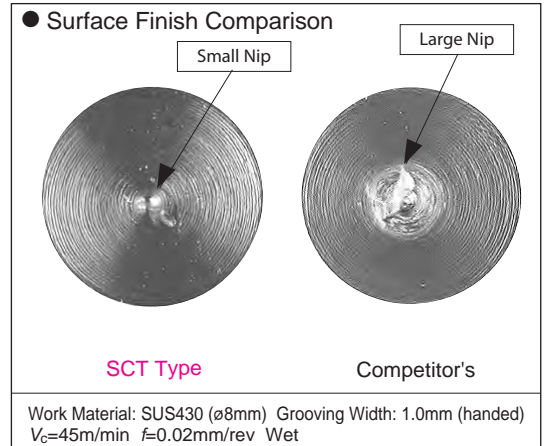
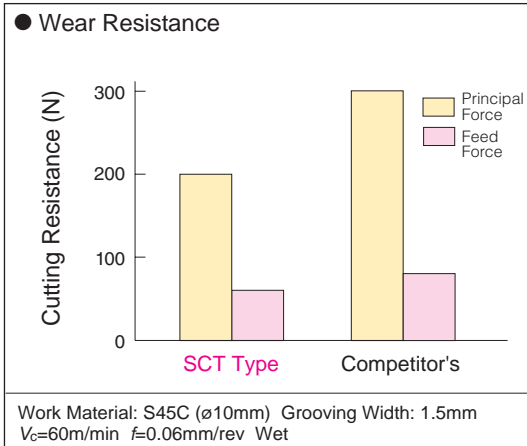

■ Insert and Holder Variations (Figures below show inserts with chipbreaker)

Holder Style	SCTR			SCTL		
Insert	CTRSSR	CTRSSN	CTRSSL	CTLSSR	CTLSSN	CTLSSL
Orientation						
Insert Shape & Dimensions						

■ Inserts (For Right-handed Holders)

Cat. No.	Coated Carbide			Max. Cut-off Diameter (mm)	Dimensions (mm)				Chipbreaker	Toolholder			
	AC530U	R	N		L	w	r _ε	L			s		
CTR 050505 R/N/L	★	★	★	5	0.5	0.05	19	7	Yes	SCT R1010 SCT R1212 SCT R1616			
CTR 050500 R/N/L	★	★		5		0							
CTR 121005 R/N/L	★	★	★	12	1.0								
CTR 121505 R/N/L	★	★	★	12	1.5								
CTR 122005 R/N/L	★	★		12	2.0								
CTR 121000 R/N/L	★	★		12	1.0								
CTR 121500 R/N/L	★	★		12	1.5	0							
CTR 122000 R/N/L	★	★		12	2.0	0							
CTR 161005 R/N/L				16	1.0	0.05	23.1	8.3			No	SCT R1010-16 SCT R1212-16 SCT R1616-16	
CTR 161505 R/N/L	★	★		16	1.5								
CTR 162005 R/N/L	★	★	★	16	2.0								
CTR 161000 R/N/L				16	1.0								
CTR 161500 R/N/L	★	★		16	1.5				0				
CTR 162000 R/N/L	★	★	★	16	2.0				0				
CTR 050500 R/N/L-NB				5	0.5	19	7	No	SCT R1010 SCT R1212 SCT R1616				
CTR 121000 R/N/L-NB	★			12	1.0								
CTR 121500 R/N/L-NB	★			12	1.5								
CTR 122000 R/N/L-NB	★			12	2.0								
CTR 161000 R/N/L-NB				16	1.0					23.1			8.3
CTR 161500 R/N/L-NB				16	1.5								
CTR 162000 R/N/L-NB	★			16	2.0								

■ Inserts (For Left-handed Holders)

Cat. No.	Coated Carbide			Max. Cut-off Diameter (mm)	Dimensions (mm)				Chipbreaker	Toolholder			
	AC530U	R	N		L	w	r _ε	L			s		
CTL 050505 R/N/L	★	★		5	0.5	0.05	19	7	Yes	SCT L1010 SCT L1212 SCT L1616			
CTL 050500 R/N/L	★	★		5		0							
CTL 121005 R/N/L	★	★	★	12	1.0								
CTL 121505 R/N/L	★	★	★	12	1.5								
CTL 122005 R/N/L	★	★		12	2.0								
CTL 121000 R/N/L	★	★		12	1.0								
CTL 121500 R/N/L	★	★		12	1.5	0							
CTL 122000 R/N/L	★	★		12	2.0	0							
CTL 161005 R/N/L				16	1.0	0.05	23.1	8.3			No	SCT L1010-16 SCT L1212-16 SCT L1616-16	
CTL 161505 R/N/L	★	★		16	1.5								
CTL 162005 R/N/L	★	★	★	16	2.0								
CTL 161000 R/N/L				16	1.0								
CTL 161500 R/N/L	★	★		16	1.5				0				
CTL 162000 R/N/L	★	★		16	2.0				0				
CTL 050500 R/N/L-NB				5	0.5	19	7	No	SCT L1010 SCT L1212 SCT L1616				
CTL 121000 R/N/L-NB				12	1.0								
CTL 121500 R/N/L-NB				12	1.5								
CTL 122000 R/N/L-NB				12	2.0								
CTL 161000 R/N/L-NB				16	1.0					23.1			8.3
CTL 161500 R/N/L-NB				16	1.5								
CTL 162000 R/N/L-NB				16	2.0								

★ Worldwide Warehouse Item



Threading, Grooving, & Cut-Off Holders

Polygon Shank TOOLHOLDERS & Bars

Pages 315-325

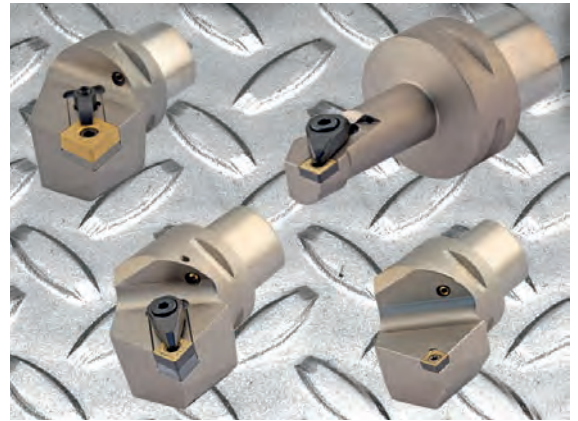

Polygon Shank

PSC POLYGON SHANK	PAGES
Nomenclature.....	316-317
Features & Benefits	318
PSC Toolholders.....	318-322
PSC Boring Bars.....	323-324
PSC Adapters.....	325

PSC

Polygon Shank Type

40-

Polygon Shank Size

Sizes:

- 32 mm
- 40 mm
- 50 mm
- 63 mm

D

Insert Holding

D
Clamp Mechanism

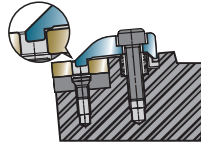

C
Clamp

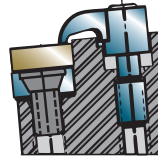

M
Clamp and Lock Pin

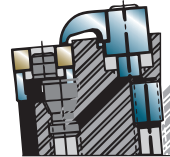

S
Screw Only

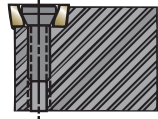

W
Wedge Clamp*

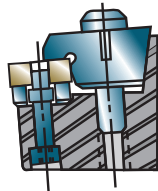



D

Insert Shape

C
Diamond 

D
Diamond 

R
Round 

S
Square 

T
Triangle 

V
Diamond 

W
Trigon 

J

Holder / Boring Bar Style

F
0° end cutting offset shank

H
-17.5° end cutting offset shank

J
-3° side cutting offset shank

K
15° end cutting offset shank

L
-5° side & end cutting offset shank

N
27.5° cutting shank

R
15° side cutting offset shank

V
17°30' side cutting straight shank

All lead angles are ±1°



N

Insert Relief Angle



R

Hand

R
Right Hand

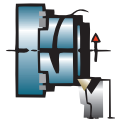
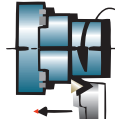

L
Left Hand

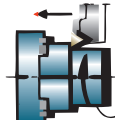

N
Neutral Hand

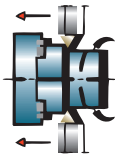

27

Distance from center (mm)

Holder Sizes:

- 22 mm
- 27 mm
- 35 mm
- 45 mm

Boring Bar Sizes:

- 11 mm
- 13 mm
- 17 mm
- 22 mm
- 27 mm

Neutral Holders f1: 0.5 mm

050

Holder Length (mm)

Holder Sizes:

- 40 mm
- 45 mm
- 50 mm
- 60 mm
- 62 mm
- 65 mm

Boring Bar Sizes:

- 65 mm
- 70 mm
- 75 mm
- 80 mm
- 90 mm
- 100 mm
- 110 mm
- 140 mm

33

Insert Size

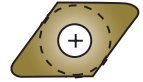

Inscribed Circle

&

Thickness



PSC TOOLHOLDERS

Series: PSC Features & Benefits • DCLN

Polygon Shank Style

PSC- Features & Benefits

- The Sumitomo polygon shank holders enable an extremely high stiffness connection between machine and tool.
- The conical polygon can take high bending and torque moments based on the combination of the face contact to the spindle.
- This self-guiding coupling system offers high precision and repeatability
- While using this easy and quick coupling system it is possible to gain higher machine utilization time as the set-up and tool change times are reduced.
- The compact design and the high stiffness connection to the spindle offer a versatile use on multi-task machines, machining centers and turning-milling centers.
- Monoblock system
- No additional interfaces
- Precise positioning; self-guiding with high repeatability
- High stiffness supported by face contact of holder
- Carbide shims to prevent holders from damage
- Simple tool holder change and low-maintenance operation
- Internal coolant supply directly to the cutting edge
- Polygon shank and insert seat hardened for long holder life

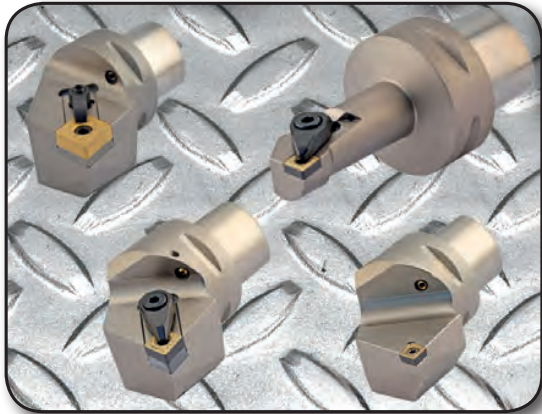

PSC-Toolholders

DCLN 95°

Characteristics:
PSC with internal coolant.

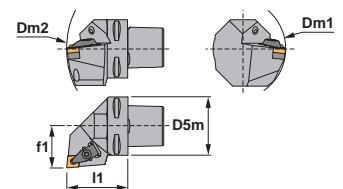

Catalog Number		D5m	Dm1 min. bore	Dm2 min. face relief	F ₁	l ₁	Rake Angle	Incline Angle	Applicable Insert	Screw	Shim	Clamp	Clamp Bolt	Spring	Wrench
Right	Left														
PSC32-DCLNR-22040-32	PSC32-DCLNL-22040-32	32	60	116	22.0	40.0	-6°	-6°	CN__32	ST-1764	ICSN-332	CL-2708	CLB-1695	SP-4294	LH030
PSC40-DCLNR-27050-32	PSC40-DCLNL-27050-32	40	60	140	27.0	50.0	-6°	-6°	CN__32						
PSC32-DCLNR-22045-43	PSC32-DCLNL-22045-43	32	60	121	22.0	45.0	-6°	-6°	CN__43						
PSC40-DCLNR-27050-43	PSC40-DCLNL-27050-43	40	110	140	27.0	50.0	-6°	-6°	CN__43						
PSC50-DCLNR-35060-43	PSC50-DCLNL-35060-43	50	110	165	35.0	60.0	-6°	-6°	CN__43	ST-1766	ICSN-442	CL-2712	CLB-1696	SP-4295	LH040
PSC63-DCLNR-45065-43	PSC63-DCLNL-45065-43	63	110	190	45.0	65.0	-6°	-6°	CN__43						
PSC40-DCLNR-27055-54	PSC40-DCLNL-27055-54	40	125	145	27.0	55.0	-6°	-6°	CN__54						
PSC50-DCLNR-35060-54	PSC50-DCLNL-35060-54	50	125	165	35.0	60.0	-6°	-6°	CN__54	ST-1768	ICSN533	CL-2716	CLB-1696	SP-4295	LH040
PSC63-DCLNR-45065-54	PSC63-DCLNL-45065-54	63	125	190	45.0	65.0	-6°	-6°	CN__54						
PSC50-DCLNR-35060-64	PSC50-DCLNL-35060-64	50	125	165	35.0	60.0	-6°	-6°	CN__64						
PSC63-DCLNR-45065-64	PSC63-DCLNL-45065-64	63	125	190	45.0	65.0	-6°	-6°	CN__64	ST-1770	ICSN633	CL-2719	CLB-1696	SP-4295	LH040



Polygon Shank Style Toolholders

PSC TOOLHOLDERS

Series: DCRN • DDJN • DDNN

PSC
Toolholders

DCRN 75°

Characteristics:
PSC with internal coolant.

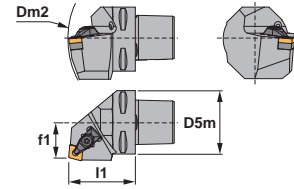

Catalog Number		D5m	Dm2 min. face relief	F1	l1	Rake Angle	Incline Angle	Applicable Insert	Screw	Shim	Clamp	Clamp Bolt	Spring	Wrench
Right	Left													
PSC40-DCRNR-22050-43	PSC40-DCRNL-22050-43	40	140	22.0	50.0	-6°	-6°	CN_ 43						
PSC50-DCRNR-27060-43	PSC50-DCRNL-27060-43	50	165	27.0	60.0	-6°	-6°	CN_ 43	ST-1766	ICSN-442	CL-2712	CLB-1696	SP-4295	LH040
PSC63-DCRNR-35065-43	PSC63-DCRNL-35065-43	63	190	35.0	65.0	-6°	-6°	CN_ 43						
PSC50-DCRNR-27060-54	PSC50-DCRNL-27060-54	50	165	27.0	60.0	-6°	-6°	CN_ 54	ST-1768	ICSN533	CL-2716	CLB-1696	SP-4295	LH040
PSC63-DCRNR-35065-54	PSC63-DCRNL-35065-54	63	190	35.0	65.0	-6°	-6°	CN_ 54						
PSC50-DCRNR-27060-64	PSC50-DCRNL-27060-64	50	165	27.0	60.0	-6°	-6°	CN_ 64	ST-1770	ICSN633	CL-2719	CLB-1696	SP-4295	LH040
PSC63-DCRNR-35065-64	PSC63-DCRNL-35065-64	63	190	35.0	65.0	-6°	-6°	CN_ 64						

DDJN 93°

Characteristics:
PSC with internal coolant.

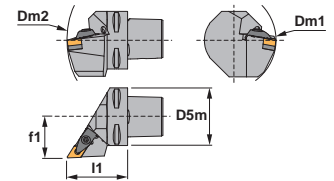

Catalog Number		D5m	Dm1 min. bore	Dm2 min. face relief	F1	l1	Rake Angle	Incline Angle	Applicable Insert	Screw	Shim	Clamp	Clamp Bolt	Spring	Wrench
Right	Left														
PSC32-DDJNR-22045-33	PSC32-DDJNL-22045-33	32	60	121	22.0	45.0	-6°	-7°	DN_ 33						
PSC40-DDJNR-27050-33	PSC40-DDJNL-27050-33	40	60	140	27.0	50.0	-6°	-7°	DN_ 33	ST-1764	IDSN322	CL-2708	CLB-1695	SP-4294	LH030
PSC50-DDJNR-35060-33	PSC50-DDJNL-35060-33	50	65	165	35.0	60.0	-6°	-7°	DN_ 33						
PSC63-DDJNR-45065-33	PSC63-DDJNL-45065-33	63	81	190	45.0	65.0	-6°	-7°	DN_ 33						
PSC50-DDJNR-35060-43	PSC50-DDJNL-35060-43	50	110	165	35.0	60.0	-6°	-7°	DN_ 43	ST-1766	IDSN443	CL-2712	CLB-1696	SP-4295	LH040
PSC63-DDJNR-45065-43	PSC63-DDJNL-45065-43	63	110	190	45.0	65.0	-6°	-7°	DN_ 43						

DDNN 63°

Characteristics:
PSC with internal coolant.

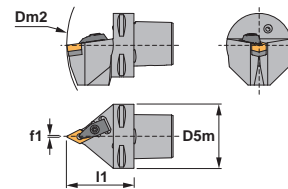

Catalog Number		D5m	Dm2 min. face relief	F1	l1	Rake Angle	Incline Angle	Applicable Insert	Screw	Shim	Clamp	Clamp Bolt	Spring	Wrench
Neutral														
PSC40-DDNNN-00050-33		40	140	0.5	50.0	-5°	-9°	DN_ 33	ST-1764	IDSN322	CL-2708	CLB-1695	SP-4294	LH030
PSC50-DDNNN-00060-33		50	165	0.5	60.0	-5°	-9°	DN_ 33						
PSC50-DDNNN-00060-43		50	165	0.5	60.0	-5°	-9°	DN_ 43	ST-1766	IDSN443	CL-2712	CLB-1696	SP-4295	LH040
PSC63-DDNNN-00065-43		63	190	0.5	65.0	-5°	-9°	DN_ 43						



PSC TOOLHOLDERS

Series: DTFN • DVJN • DVVN

Polygon Shank Style Toolholders

DTFN 90°

Characteristics:

PSC with internal coolant.

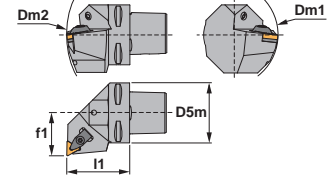

Catalog Number		D5m	Dm1 min. bore	Dm2 min. face relief	F ₁	l ₁	Rake Angle	Incline Angle	Applicable Insert	Screw	Shim	Clamp	Clamp Bolt	Spring	Wrench
Right	Left														
PSC63-DTFNR-45065-33	PSC63-DTFNL-45065-33	63	110	190	45.0	65.0	-6°	-6°	TN_33	ST-1764	ITSN-342	CL-2708	CLB-1695	SP-4294	LH030
PSC50-DTFNR-35060-43	PSC50-DTFNL-35060-43	50	110	165	35.0	60.0	-6°	-6°	TN_43	ST-1764	ITSN-442	CL-2712	CLB-1696	SP-4295	LH040
PSC63-DTFNR-45065-43	PSC63-DTFNL-45065-43	63	110	190	45.0	65.0	-6°	-6°	TN_43	ST-1764	ITSN-442	CL-2712	CLB-1696	SP-4295	LH040

DVJN 93°

Characteristics:

PSC with internal coolant.

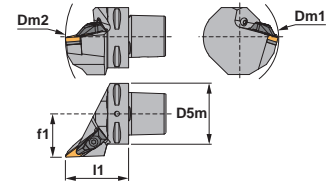

Catalog Number		D5m	Dm1 min. bore	Dm2 min. face relief	F ₁	l ₁	Rake Angle	Incline Angle	Applicable Insert	Screw	Shim	Clamp	Clamp Bolt	Spring	Wrench
Right	Left														
PSC40-DVJNR-27062-33	PSC40-DVJNL-27062-33	40	60	152	27.0	62.0	-6°	-13°	VN_33	ST-1764	IVSN322	CL-2708	CLB-1695	SP-4294	LH030
PSC50-DVJNR-35065-33	PSC50-DVJNL-35065-33	50	65	170	35.0	65.0	-6°	-13°	VN_33	ST-1764	IVSN322	CL-2708	CLB-1695	SP-4294	LH030
PSC63-DVJNR-45065-33	PSC63-DVJNL-45065-33	63	81	190	45.0	65.0	-6°	-13°	VN_33	ST-1764	IVSN322	CL-2708	CLB-1695	SP-4294	LH030

DVVN 72° 30'

Characteristics:

PSC with internal coolant.

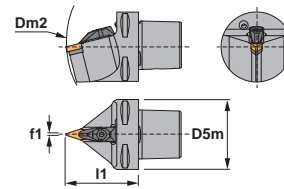

Catalog Number		D5m	Dm2 min. face relief	F ₁	l ₁	Rake Angle	Incline Angle	Applicable Insert	Screw	Shim	Clamp	Clamp Bolt	Spring	Wrench
Neutral														
PSC40-DVVNN-00062-33		40	152	0.6	62.0	-4°	-13°	VN_33	ST-1764	IVSN322	CL-2708	CLB-1695	SP-4294	LH030
PSC50-DVVNN-00065-33		50	170	0.6	65.0	-4°	-13°	VN_33	ST-1764	IVSN322	CL-2708	CLB-1695	SP-4294	LH030
PSC63-DVVNN-00065-33		63	190	0.6	65.0	-4°	-13°	VN_33	ST-1764	IVSN322	CL-2708	CLB-1695	SP-4294	LH030



Polygon Shank Style Toolholders

PSC TOOLHOLDERS

Series: DWLN • MCLN • SCLC

PSC
Toolholders

DWLN 95°

Characteristics:
PSC with internal coolant.

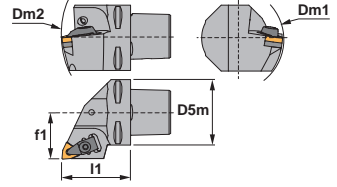

Catalog Number		D5m	Dm1 min. bore	Dm2 min. face relief	F ₁	l ₁	Rake Angle	Incline Angle	Applicable Insert	Screw	Shim	Clamp	Clamp Bolt	Spring	Wrench
Right	Left														
PSC32-DWLN-22040-33	PSC32-DWLN-22040-33	32	60	116	22.0	40.0	-6°	-6°	WN__33	ST-1764	IWSN322	CL-2708	CLB-1695	SP-4294	LH030
PSC40-DWLN-27050-33	PSC40-DWLN-27050-33	40	60	140	27.0	50.0	-6°	-6°	WN__33						
PSC50-DWLN-35060-33	PSC50-DWLN-35060-33	50	60	165	35.0	60.0	-6°	-6°	WN__33						
PSC63-DWLN-45065-33	PSC63-DWLN-45065-33	63	110	190	45.0	65.0	-6°	-6°	WN__33						
PSC40-DWLN-27050-43	PSC40-DWLN-27050-43	40	110	140	27.0	50.0	-6°	-6°	WN__43	ST-1766	IWSN433	CL-2712	CLB-1696	SP-4294	LH040
PSC50-DWLN-35060-43	PSC50-DWLN-35060-43	50	110	165	35.0	60.0	-6°	-6°	WN__43						
PSC63-DWLN-45065-43	PSC63-DWLN-45065-43	63	110	190	45.0	65.0	-6°	-6°	WN__43						

MCLN 95°

Characteristics:
PSC with internal coolant.

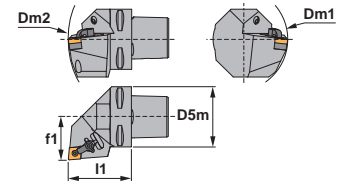

Catalog Number		D5m	Dm1 min. bore	Dm2 min. face relief	F ₁	l ₁	Rake Angle	Incline Angle	Applicable Insert	Screw	Shim	Clamp	Clamp Bolt	Wrench	Wrench
Right	Left														
PSC50-MCLN-35060-64		50	125	165	35.0	60.0	-6°	-6°	CN__64	ST-1085	ICSN633	CL-2614	PN-1673	LH030	LH040
	PSC63-MCLN-45065-64	63	125	190	45.0	65.0	-6°	-6°	CN__64						

SCLC 95°

Characteristics:
PSC with internal coolant.

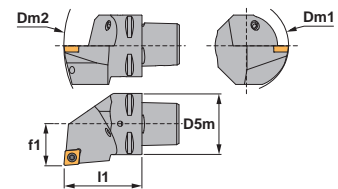

Catalog Number		D5m	Dm1 min. bore	Dm2 min. face relief	F ₁	l ₁	Rake Angle	Incline Angle	Applicable Insert	Screw	Wrench	Shim	Shim Screw
Right	Left												
PSC40-SCLC-27050-32.5	PSC40-SCLC-27050-32.5	40	80	140	27.0	50.0	0°	0°	CC__32.5	BFTX0407N	TRX15	-	-
PSC50-SCLC-35060-32.5	PSC50-SCLC-35060-32.5	50	80	165	35.0	60.0	0°	0°	CC__32.5				
PSC63-SCLC-45065-32.5	PSC63-SCLC-45065-32.5	63	80	190	45.0	65.0	0°	0°	CC__32.5				
	PSC63-SCLC-45065-43	63	110	190	45.0	65.0	0°	0°	CC__43	BFTX0405	TRX15040	SH-3614	ST-1540



SDJC 93°

Characteristics:
PSC with internal coolant.

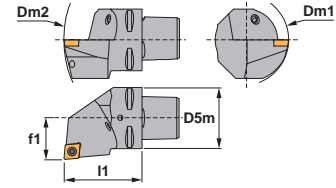

Catalog Number		D5m	Dm1 min. bore	Dm2 min. face relief	F ₁	l ₁	Rake Angle	Incline Angle	Applicable Insert	Screw	Wrench	Shim	Shim Screw
Right	Left												
PSC32-SDJCR-22040-32.5	PSC32-SDJCL-22040-32.5	32	110	124	22.0	40.0	0°	0°	DC__ 32.5	BFTX03515	TRX15	SH-3714	ST-1750
PSC40-SDJCR-27050-32.5	PSC40-SDJCL-27050-32.5	40	110	140	27.0	50.0	0°	0°	DC__ 32.5				
PSC50-SDJCR-35060-32.5	PSC50-SDJCL-35060-32.5	50	110	165	35.0	60.0	0°	0°	DC__ 32.5				
PSC63-SDJCR-45065-32.5	PSC63-SDJCL-45065-32.5	63	110	190	45.0	65.0	0°	0°	DC__ 32.5				

SVHB 107° 30'

Characteristics:
PSC with internal coolant.

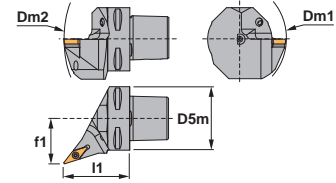

Catalog Number		D5m	Dm1 min. bore	Dm2 min. face relief	F ₁	l ₁	Rake Angle	Incline Angle	Applicable Insert	Screw	Wrench	Shim	Shim Screw
Right	Left												
PSC50-SVHBR-35060-33		50	110	165	35.0	60.0	0°	0°	VB__ 33	BFTX03515	TRX15	SH-3718	ST-1750

SVJB 93°

Characteristics:
PSC with internal coolant.

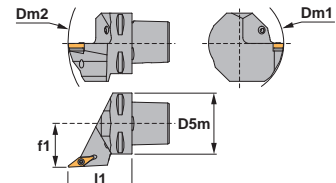

Catalog Number		D5m	Dm1 min. bore	Dm2 min. face relief	F ₁	l ₁	Rake Angle	Incline Angle	Applicable Insert	Screw	Wrench	Shim	Shim Screw
Right	Left												
PSC40-SVJBR-27050-33	PSC40-SVJBL-27050-33	40	110	145	27.0	50.0	0°	0°	VB__ 33	BFTX03515	TRX15	SH-3718	ST-1750
PSC50-SVJBR-35060-33	PSC50-SVJBL-35060-33	50	110	165	35.0	60.0	0°	0°	VB__ 33				
PSC63-SVJBR-45065-33	PSC63-SVJBL-45065-33	63	110	190	45.0	65.0	0°	0°	VB__ 33				

SVJC 93°

Characteristics:
PSC with internal coolant.

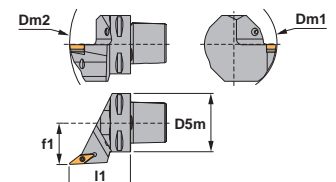

Catalog Number		D5m	Dm1 min. bore	F ₁	l ₁	Rake Angle	Incline Angle	Applicable Insert	Screw	Wrench	Shim	Shim Screw
Right	Left											
PSC40-SVJCR-27050-33	PSC40-SVJCL-27050-33	40	80	27.0	50.0	0°	0°	VC__ 33	BFTX03515	TRX15	SH-3718	ST-1750
PSC50-SVJCR-35060-33	PSC50-SVJCL-35060-33	50	80	35.0	60.0	0°	0°	VC__ 33				



PSC-Boring Bars

DCLN 95°

Characteristics:
PSC with internal coolant.

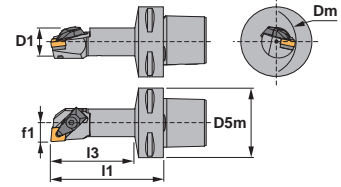

Catalog Number		Dm min. bore	D1	D5m	F1	l1	l3	Rake Angle	Incline Angle	Applicable Insert	Screw	Shim	Clamp	Clamp Bolt	Spring	Wrench
Right	Left															
PSC40-DCLNR-13080-32	PSC40-DCLNL-13080-32	25.0	20	40	13.0	80	57	-6°	-6°	CN__32	ST-1764	ICSN-332	CL-2708	CLB-1695	SP-4294	LH030
PSC40-DCLNR-17090-43	PSC50-DCLNL-17090-43	32.0	25	40	17.0	90	68	-6°	-6°	CN__43						
PSC50-DCLNR-17090-43		32.0	25	50	17.0	90	66	-6°	-6°	CN__43	ST-1766	ICSN-442	CL-2712	CLB-1696	SP-4295	LH040
PSC63-DCLNR-17100-43	PSC63-DCLNL-17100-43	32.0	25	63	17.0	100	72	-6°	-6°	CN__43						
PSC63-DCLNR-27140-54	PSC63-DCLNL-27140-54	50.0	40	63	27.0	140	114	-6°	-6°	CN__54	ST-1768	ICSN533	CL-2716	CLB-1696	SP-4295	LH040

DWLN 95°

Characteristics:
PSC with internal coolant.

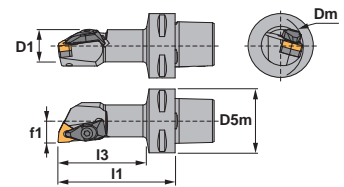

Catalog Number		Dm min. bore	D1	D5m	F1	l1	l3	Rake Angle	Incline Angle	Applicable Insert	Screw	Shim	Clamp	Clamp Bolt	Spring	Wrench
Right	Left															
PSC40-DWLN-13075-33	PSC40-DWLN-13075-33	33.0	20	40	13.0	75	52	-6°	-17°	WN__33	ST-1764	IWSN322	CL-2708	CLB-1695	SP-4294	LH030
PSC40-DWLN-17090-43	PSC40-DWLN-17090-43	35.0	25	40	17.0	90	68	-6°	-12°	WN__43	ST-1766	IWSN433	CL-2712	CLB-1696	SP-4294	LH040
PSC50-DWLN-17090-43	PSC50-DWLN-17090-43	35.0	25	50	17.0	90	66	-6°	-12°	WN__43						

SCLC 95°

Characteristics:
PSC with internal coolant.

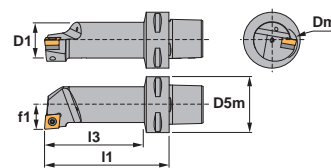

Catalog Number		Dm min. bore	D1	D5m	F1	l1	l3	Rake Angle	Incline Angle	Applicable Insert	Screw	Wrench
Right	Left											
	PSC32-SCLCL-11065-32.5	20.0	16.0	32	11.0	65	48	0°	-12°	CC__32.5		
PSC40-SCLCR-11070-32.5	PSC40-SCLCL-11070-32.5	20.0	16.0	40	11.0	70	47	0°	-12°	CC__32.5		
PSC40-SCLCR-13080-32.5	PSC40-SCLCL-13080-32.5	25.0	20.0	40	13.0	80	58	0°	-8°	CC__32.5		
PSC40-SCLCR-17090-32.5	PSC40-SCLCL-17090-32.5	32.0	25.0	40	17.0	90	69	0°	-6°	CC__32.5	BFTX0407N	TRX15
PSC50-SCLCR-11070-32.5	PSC50-SCLCL-11070-32.5	20.0	16.0	50	11.0	70	46	0°	-12°	CC__32.5		
PSC50-SCLCR-13080-32.5	PSC50-SCLCL-13080-32.5	25.0	20.0	50	13.0	80	56	0°	-8°	CC__32.5		
PSC50-SCLCR-17090-32.5	PSC50-SCLCL-17090-32.5	32.0	25	50	17.0	90	67	0°	-6°	CC__32.5		



SSK 75°

Characteristics:
PSC with internal coolant.

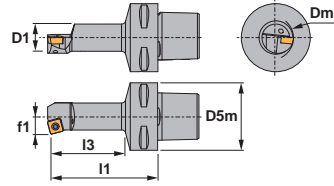

Catalog Number		Dm min. bore	D1	D5m	F1	l1	l3	Rake Angle	Incline Angle	Applicable Insert	Screw	Wrench
Right	Left											
PSC40-SSKCR-13080-32.5	PSC40-SSKCL-13080-32.5	25.0	20	40	13.0	80	58	0°	-6°	SC__32.5	BFTX0407N	TRX15

STFC 90°

Characteristics:
PSC with internal coolant.

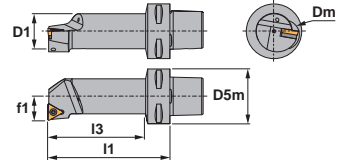





Catalog Number		Dm min. bore	D1	D5m	F1	l1	l3	Rake Angle	Incline Angle	Applicable Insert	Screw	Wrench	Shim	Clamp Bolt
Right	Left													
PSC32-STFCR-11065-21.5	PSC32-STFCL-11065-21.5	20.0	16	32	11.0	65.0	48.0	0°	-4°	TC__21.5	BFTX02507	TRX15040	-	-
PSC32-STFCR-13075-21.5	PSC32-STFCL-13075-21.5	25.0	20	32	13.0	75.0	59.0	0°	-3°	TC__21.5				
PSC40-STFCR-11070-21.5	PSC40-STFCL-11070-21.5	20.0	16	40	11.0	70.0	47.0	0°	-4°	TC__21.5				
PSC40-STFCR-13080-21.5	PSC40-STFCL-13080-21.5	25.0	20	40	13.0	80.0	57.0	0°	-3°	TC__21.5				
PSC50-STFCR-11070-21.5	PSC50-STFCL-11070-21.5	20.0	16	50	11.0	70.0	46.0	0°	-4°	TC__21.5				
PSC50-STFCR-13080-21.5	PSC50-STFCL-13080-21.5	25.0	20	50	13.0	80.0	56.0	0°	-3°	TC__21.5				
PSC32-STFCR-17090-32.5	PSC32-STFCL-17090-32.5	32.0	25	32	17.0	90.0	74.0	0°	-3.5°	TC__32.5	BFTX0407N	TRX15	-	-
PSC40-STFCR-17090-32.5	PSC40-STFCL-17090-32.5	32.0	25	40	17.0	90.0	69.0	0°	-6°	TC__32.5				
PSC40-STFCR-22110-32.5	PSC40-STFCL-22110-32.5	40.0	32	40	22.0	110.0	89.0	0°	-10°	TC__32.5	BFTX03515	TRX15	SH-3714	ST-1750
PSC50-STFCR-17090-32.5	PSC50-STFCL-17090-32.5	32.0	25	50	17.0	90.0	67.0	0°	-6°	TC__32.5	BFTX0407N	TRX15	-	-
PSC50-STFCR-22110-32.5	PSC50-STFCL-22110-32.5	40.0	32	50	22.0	110.0	88.0	0°	-10°	TC__32.5	BFTX03515	TRX15	SH-3714	ST-1750

PSC-ADAPTERS

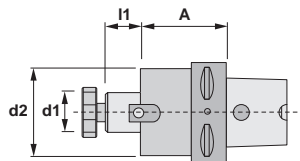
PSC Adapters

PSC ADAPTERS

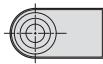

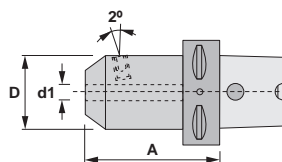

PSC Shell Mill Holders								
Catalog Number	Dimensions					Cap	Drive Key	Screw
	PSC	D1	L	L1	D2			
PSC50-0.75SMH	50	.750	2.756	0.709	1.693	CAP-10107	DRKEY-86207	ST-11103
PSC50-1.00SMH	50	1.000	0.984	0.709	2.126	CAP-10110	DRKEY-86210	ST-11004
PSC50-1.50SMH	50	1.50	1.772	0.906	3.150	CAP-10115	DRKEY-86215	ST-11006
PSC63-0.75SMH	63	.750	1.181	0.709	2.047	CAP-10107	DRKEY-86207	ST-11103
PSC63-1.00SMH	63	1.000	1.181	0.709	2.480	CAP-10110	DRKEY-86210	ST-11004
PSC63-1.50SMH	63	1.50	1.772	0.906	3.150	CAP-10115	DRKEY-86215	ST-11006



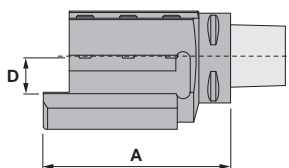

PSC Boring Bar Adapters					2 x 
Catalog Number	Dimensions				Bolt
	PSC	D1	D	L	
PSC40-0.75BBA	40	.750	1.752	2.362	BOLT-15407
PSC50-0.75BBA	50	.750	1.752	2.362	BOLT-15407
PSC50-1.00BBA	50	1.000	2.248	3.346	BOLT-15410*
PSC50-1.25BBA	50	1.250	2.480	3.347	BOLT-15410*
PSC63-0.75BBA	63	.7500	1.752	2.560	BOLT-15407
PSC63-1.00BBA	63	1.000	2.248	3.347	BOLT-15410*
PSC63-1.25BBA	63	1.250	2.480	3.347	BOLT-15410*

* has 4 bolts instead of standard 2

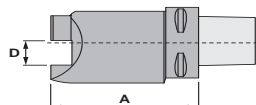

PSC Straight Square Shank Toolholder Adapter							
Catalog Number		Dimensions				Clamp Bolt	Coolant Bolt
Right	Left	PSC	Type	D	L		
PSC50-0.75THR	PSC50-0.75THL	50	Turning toolholder for square tool left/right hand	.750	3.858	CLB-17207	COB-29708
PSC63-0.75THR	PSC63-0.75THL	63		.750	3.937	CLB-17207	COB-29708
PSC63-1.00THR	PSC63-1.00THL	63		1.000	5.118	CLB-17210	COB-29708



PSC 90° Square Shank Toolholder Adapter								
Catalog Number		Dimensions				Clamp Bolt	Coolant Bolt	
Right	Left	PSC	Type	D	L			
PSC50-0.75STHR	PSC50-0.75STHL	50	Turning toolholder for square tool left/right hand	.750	3.791	CLB-17207	COB-29708	
PSC63-0.75STHR	PSC63-0.75STHL	63		.750	3.870	CLB-17207	COB-29708	





SUMITOMO

CARBIDE - CBN - DIAMOND

1-800-950-5202

www.sumicarbide.com

MILLING INFORMATION

Pages 327-439



Milling











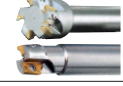

MILLING SYSTEMS	PAGES
Indexable Milling Selection Guide.....	328-329
Shoulder Milling.....	331-353
Face Milling	355-372
High Feed Milling.....	373-377
Multi-Purpose Milling.....	379-392
Modular Tooling.....	393-399
PCD & PCBN Milling	401-412
Discontinued Items Section.....	413-425
Solid Carbide Endmills.....	426-439

INDEXABLE MILLING SELECTION GUIDE

P Steel **K** Cast Iron **S** Exotic Materials
M Stainless Steel **N** Non-ferrous **H** Hardened Steel



























✓: Best ○: Good X: Unsuitable Blank: Not recommended

Selection Guide

Milling Type	Cutter Type	Series	Insert	Lead Angle	Rake Angle		Diameter	Application										Applicable Work Material						Page #		
					Axial	Radial		Face Milling		Shoulder Milling	Slot Milling	Ramping	Copying	Chamfering	Boring	Finishing	P	M	K	N	S	H				
								General Purpose	Finishing								High Feed	General & Carbon Steel/Inconel Steel	Die Steel - Tempered Steel	Stainless Steel	Cast Iron - Ductile Iron	Non-ferrous Metal	Aluminum Alloy		Ti Alloy - Heat Resistant Alloy	Hardened Steel 45-55 HRC
Shoulder Milling	WEX-E 	WEX2000 WEX3000	AXMT12 AXMT17	0°	14° ~ 25°	10° ~ 18°	0.500" ~ 2.000"	○			✓	✓	✓					✓	✓	✓	✓	✓	✓	332 -337		
	WEX-R 	WEX2000 WEX3000			23° ~ 25°	16° ~ 18°	1.500" ~ 8.000"	○												✓	✓	✓	✓		✓	✓
	WRX-E 	WRX2000 WRX3000	AXMT12 AXMT17	0°	16° ~ 24°	13° ~ 16°	1.000" ~ 2.000"	○				✓	✓	✓					✓	✓	✓	✓	✓	338-341		
	WRX-R 	WRX2000 WRX3000			24° ~ 22°	16° ~ 13°	2.500" ~ 3.000"	○												✓	✓	✓	✓		✓	✓
	WAX 	WAX3000 WAX4000	AECT16 AECT22	0°	19° ~ 25°	6°	0.750" ~ 1.500"	○				✓	✓	✓	✓				X	X	X	X	○	✓	X	342-345
	WAX-E 	WAX3000 WAX4000			2.500" ~ 5.000"	○														X	X	X	X	○	✓	
	TSX-R 	TSX3000 TSX4000	LNEX08 LNEX13	0°	-6°	-34° ~ -20°	1.500" ~ 6.000"	○				✓	✓	✓										✓	346-347	
	TSX-E 	TSX3000 TSX4000			-6°	-34° ~ -31° ~ -15°	0.625" ~ 1.500"	○						✓	✓	✓										✓
	PWS 	PWS40000	LNMX17	0°	-5°	-15°	2.000" ~ 6.000"	○				✓	○	○											348-350	
	WFX 	WFX4000	SOMT12	0°	8°	-8°	2.000" ~ 8.000"	○					✓	○											351-353	
WFX-E 	WFX12000	40mm ~ 80mm					○																			
Face Milling	WGX-R 	WGX4000	SEMT13	45°	20° ~ 22°	-20° ~ -24°	2.000" ~ 8.000"	✓																356-359		
	WGX-E 	WGX4000			20° ~ 22°	-20° ~ -24°	2.000" ~ 2.500"	✓																		



INDEXABLE MILLING SELECTION GUIDE

Milling Type	Cutter Type	Series	Insert	Lead Angle	Rake Angle		Diameter	Application											Applicable Work Material						Page #		
					Axial	Radial		Face Milling			Shoulder Milling	Slot Milling	Ramping	Copying	Chamfering	Boring	Finishing	P	M	K	N	S	H				
								General Purpose	Finishing	High Feed								General & Carbon Steel Alloy Steel	Dis Steel - Tempered Steel	Stainless Steel	Cast Iron - Ductile Iron	Non-ferrous Metal	Aluminum Alloy	Ti Alloy - Heat Resistant Alloy		Hardened Steel 45-55 HRC	
Face Milling	 DGC-R	DGC4000	SNMT13 ONMT05		-5°	-10°	2.000" 10.000"	✓																	360-363		
	 DGC-E	DGC4000			-5°	-10°	2.000"	✓																			
	 DFC-R	DFC2000	XNMT06		-5°	-9°	2.000" 8.000"	✓		✓																364-367	
	 DFC-E	DFC2000			-5°	-9°	1.000" 2.500"	✓		✓																	
	 GOALMILL	GFV5000	LNGX16		-5°	-8°	4.000" 8.000"		✓	✓																	368-369
	 DNX	DNX4000	SNMT12		-5°	-6°	3.000" 8.000"																				370-371
 Spider Mill	SDP4000 SDP5000	SNMX12 SNEX15		-5°	-15°	2.000" 6.000"																				372	
High Feed Milling	 MSX-E	MSX2000 MSX3000 MSX4000	WDMT06 WDMT08 WDMT12		8°	-3° -8°	0.750" 6.000"																			374-376	
	 MSX-R	MSX3000 MSX4000 MSX5000	WDMT08 WDMT12 WDMT14		8°	-3° -8°	1.500" 6.000"																				
	 Metal Slash Mill	MS14000	SDEW14 SDMW14		10°	-5°	2.000" 4.000"			✓																	377
Face Milling	 RSX-R	RSX3000 RSX4000 RSX5000	RDET10 RDET12 RDET16	-	10°	-5.5°	1.000" 6.000"	✓																		380-383	
	 RSX-E	RSX3000 RSX4000	RDET10 RDET12	-	10°	-5.5°	1.000" 1.500"	✓																		Also see WRCX pg. 384-385	
	 WBMR	WBMR	ZNMT	-	-10°	-	0.750" 2.000"																				386-388
	 WBMF	WBMF	ZPGU	-	0°	-	0.500" 1.250"																				389-390
	 WMM	WMM10000 WMM16000	APMT10 APMT16		7° 11°	15° 16°	1.000" 1.500"	✓																			391-392



GRADE APPLICATIONS

• for Steel & Stainless Steel

Grade	Coating	Description
ACP100	CVD	Al ₂ O ₃ based "Super FF" coating with an ultra fine TiCN layer for high speed and wet cutting of steels and stainless steels; super tough substrate for better wear and thermal cracking resistance.
ACP200	PVD	Multi-layered "Super ZX" coating consisting of nanometer thick TiAlN and AlCrN layers, coupled with fine-grained tough substrate for excellent balance of fracture and wear resistance; for general purpose milling of steels and stainless steels.
ACP300	PVD	Multi-layered "Super ZX" coating consisting of nanometer thick TiAlN and AlCrN layers, coupled with fine-grained super tough substrate for excellent fracture resistance; ideal for interrupted machining of steels and stainless steels.

• for Cast Iron

Grade	Coating	Description
ACK100	CVD	Al ₂ O ₃ based "Super FF" coating with an ultra fine TiCN layer provides excellent anti-adhesion and wear resistance in general purpose milling of gray and ductile cast irons.
ACK200	CVD	Al ₂ O ₃ based "Super FF" coating with an ultra fine TiCN layer provides excellent anti-adhesion and wear resistance in general purpose milling of gray and ductile cast irons.
ACK300	PVD	Multi-layered "Super ZX" coating consisting of nanometer thick TiAlN and AlCrN layers, coupled with fine-grained super tough substrate for excellent fracture resistance; for general to interrupted machining of gray and ductile cast irons.

• for Superalloys and Stainless Steels

Grade	Coating	Description
ACM100	PVD	Multi-layered "Super ZX" coating consisting of nanometer thick TiAlN and AlCrN layers, coupled with fine-grained super tough substrate for excellent fracture resistance; for finishing of superalloys and stainless steels; excels in roughing and finishing of titanium
ACM200	CVD	Al ₂ O ₃ based "Super FF" coating with an ultra fine TiCN layer provides excellent anti-adhesion and wear resistance in general purpose milling of superalloys and stainless steels.
ACM300	PVD	Multi-layered "Super ZX" coating consisting of nanometer thick TiAlN and AlCrN layers, coupled with fine-grained super tough substrate for excellent fracture resistance; for general to interrupted machining of superalloys and stainless steels.

• for Non-ferrous Material

Grade	Coating	Description
DL1000	DLC	"Diamond-like Carbon" coated grade with exceptional wear resistance and superior surface finish capabilities when milling non-ferrous materials.
H1	J-Polish	Uncoated carbide grade with "J-Polish" to reduce chip adhesion when finish milling non-ferrous materials



SHOULDER MILLING

Pages 331-353



Table of Contents

Shoulder Milling Cutters:	Pages
WEX Series Endmills/Shell Mills	332-337
WRX Series Endmills/Shell Mills	338-341
WAX Series Endmills/Shell Mills	342-345
TSX Series Endmills/Shell Mills	346-347
PWS Series Shell Mills.....	348-350
WFX Series Endmills/Shell Mills	351-353

Indexable Milling

Shoulder Milling

Face Milling

High Feed Milling

Multi-purpose

Modular Tooling

UFO & SumiMill

Discontinued

High efficiency machining due to its optimized cutting edge geometry and highly rigid body

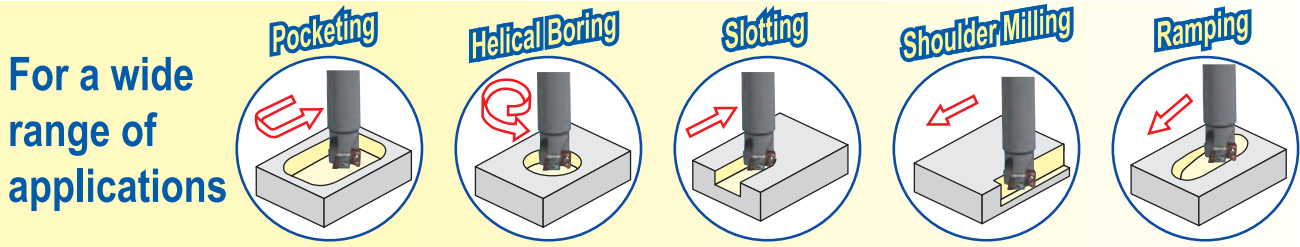

Tough, sharp and highly accurate cutting edge geometry

- The unique shape and strength of the cutting edge has improved resulting in reduced cutting forces
- Insert facet generates high quality surface finishes

Wide selection of insert geometries and grades

- Available in 6 different geometries (L, G, H, E, EH & S)
- 9 milling grades to cover a wide variety of applications

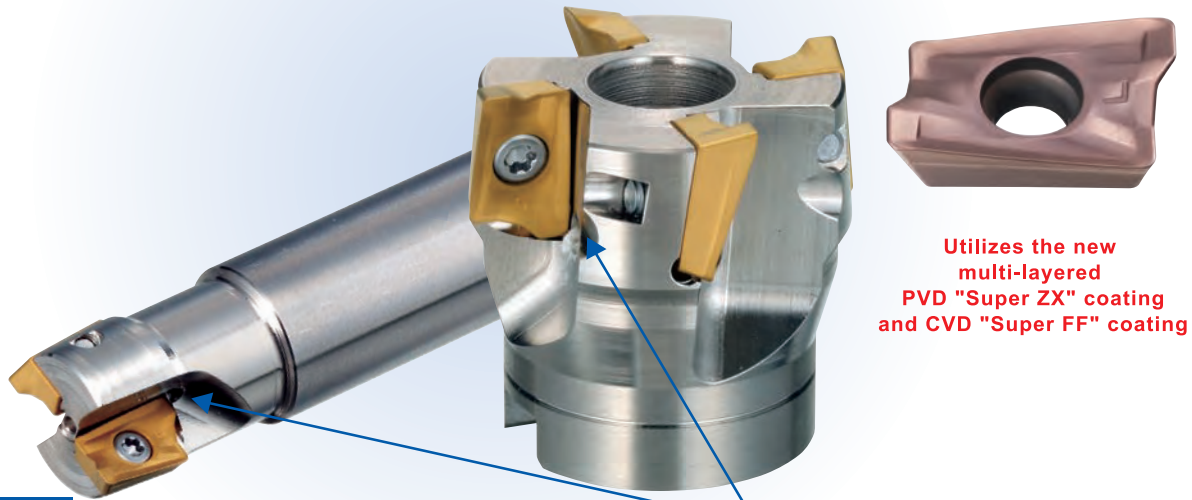

Utilizes the new multi-layered PVD "Super ZX" coating and CVD "Super FF" coating

Highly durable

- Cutter body and insert strength provide for high feed rate capabilities

Internal Coolant Holes

- Efficient chip evacuation with coolant hole design

■ Cutting Performance

- Shoulder accuracy generated in profile machining

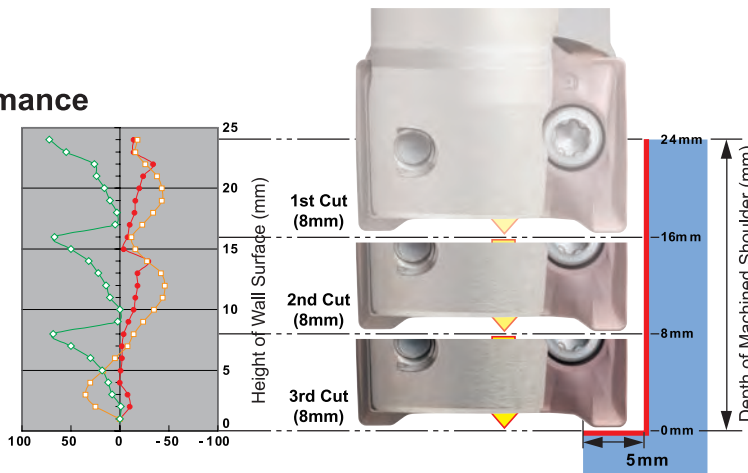
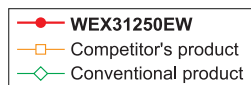

Minimal depth of cut variation due to assembly precision!



Indexable Milling
Shoulder Milling
Face Milling
High Feed Milling
Multi-purpose
Modular Tooling
UFO & SumiMill
Discontinued

Work Material	P Steel K Cast Iron			M Stainless Steel S Exotic Alloy		N Aluminium Alloy
	L Type	G Type	H Type	E Type	EH Type	S Type
Breaker						
Feature	Low Cutting Force	General Purpose	Strong Edge	General Purpose	Strong Edge	High Rake Type
2000 Type Insert Figure	Not Available					
3000 Type Insert Figure						
Application	Light cut, low rigidity milling and reduce burrs	Main breaker General purpose to interrupted milling	Roughing, heavy interrupted and hardened steel milling	Light Cutting to General Purpose	Heavy Interrupted Machining	Aluminium, Non-Ferrous Metal

Recommended Cutting Conditions

ISO	Material	Hardness	Grade	Depth of Cut			Feed per Tooth
				.002 - .050	.050 - .125	.125 & over	
P	Low and Medium Carbon Steels	<250 Bhn	ACP100	775-1310	725-1275	675-1225	.006-.0125
			ACP200	721-1213	675-1180	600-1125	.006-.0135
			ACP300	675-1075	650-1025	525-925	.006-.014
	Medium Carbon Alloy Steels	<250 Bhn	ACP100	600-975	575-950	550-900	.006-.0095
			ACP200	550-900	525-900	500-875	.006-.0115
			ACP300	525-875	500-825	475-800	.006-.0115
	Medium-High Carbon Steels	<250 Bhn	ACP100	600-975	575-950	550-900	.006-.011
			ACP200	575-950	550-925	500-875	.006-.012
			ACP300	575-950	550-925	500-875	.006-.012
	Free Machining Steels and Alloys	<250 Bhn	ACP100	725-1300	700-1250	675-1200	.006-.0135
			ACP200	750-1325	725-1275	675-1225	.006-.0135
			ACP300	675-1075	650-1050	650-1025	.006-.014
	Tool Steels	<250 Bhn	ACP100	475-820	450-790	425-750	.0047-.010
			ACP200	450-820	435-790	425-750	.0047-.011
			ACP300	450-820	425-790	400-725	.0047-.012
		bhn 220 - 350	ACP100	400-775	400-735	400-700	.004-.009
			ACP200	425-750	400-725	375-690	.0045-.010
			ACP300	420-700	420-695	375-685	.0047-.012
>33 Hrc	ACP100	325-650	300-625	300-590	.003-.007		
	ACP200	325-650	300-625	300-590	.0045-.0095		
	ACP300	325-650	300-625	300-590	.0045-.0095		
M	Martensitic and Ferritic	<250 Bhn	ACM300	535-850	520-830	275-820	.004-.011
		>250 Bhn	ACM200	425-740	415-720	375-675	.004-.012
	Austenitic	<250 Bhn	ACM300	325-875	300-850	275-825	.004-.012
		<250 Bhn	ACM200	525-850	500-825	175-675	.004-.012
K	Grey Cast Iron	>250 Bhn	ACK200	700-1050	625-925	590-900	.004-.014
			ACK300	600-950	575-875	550-850	.004-.014
		<250 Bhn	ACK200	600-950	525-825	490-800	.004-.014
		ACK300	500-850	475-775	450-750	.004-.014	
	Ductile Iron	>250 Bhn	ACK200	600-925	550-875	490-800	.004-.012
			ACK300	550-825	550-825	450-750	.004-.012
S	Exotic Alloys: Inconel, Hastalloy, Waspalloy, etc.		ACK200	100-160	70-150	60-135	.003-.0075
			ACK300	100-160	70-150	60-135	.004-.0075
N	Non-Ferrous Material		H1	1500-3800	1300-3700	1200-3600	.004-.014
			DL1000	1500-4500	1475-4200	1275-4100	.004-.014

Application Range

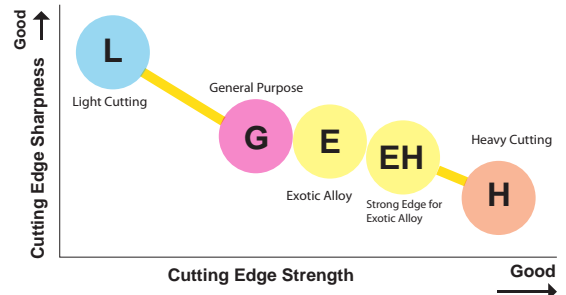
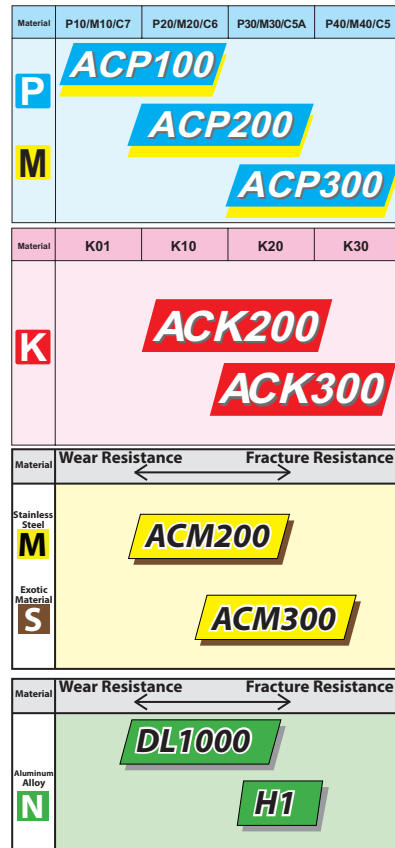

INCH

WEX 2000

APPLICABLE INSERT:

AXMT
AXET

METRIC

WEX 2000

APPLICABLE INSERT:

AXMT
AXET

EXPANSION!
SEE BELOW

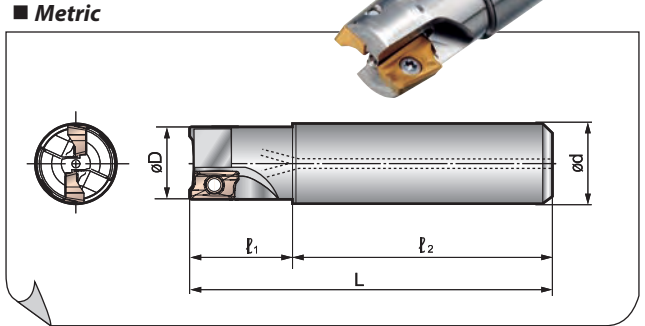
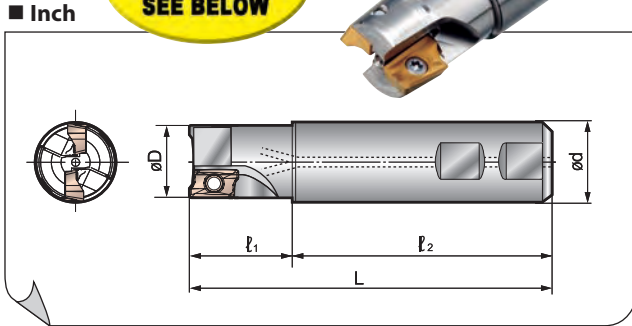

WEX 2000 Endmill

Catalog Number	Stock	Dimensions (inch)					Ramp Angle	Insert Qty.
		D	d	L	ℓ ₁	ℓ ₂		
WEX20500EW	●	0.500	0.750	3.325	1.309	2.031	5°	1
WEX20625EW	●	0.625	0.625	3.218	1.312	1.906	4°	2
WEX20625EMW	●	0.625	0.625	3.591	1.685	1.906	4°	2
WEXC20750EW	●	0.750	0.750	3.561	1.530	2.031	4°	2
WEXC20750ELC	●	0.750	0.750	8.000	3.080	6.000	4°	2
WEX20750EW	●	0.750	0.750	3.561	1.530	2.031	4°	3
WEX20750EMW	●	0.750	0.750	4.091	2.060	2.031	4°	3
WEX20750ELW	●	0.750	0.750	5.091	3.060	2.031	4°	3
WEX20750ELC	●	0.750	0.750	10.000	3.080	6.920	4°	3
WEXC21000EW	●	1.000	1.000	3.812	1.531	2.281	2°	3
WEXC21000EMW	●	1.000	1.000	4.841	2.560	2.281	2°	3
WEX21000EW	●	1.000	1.000	3.811	1.530	2.281	2°	4
WEX21000ELC	●	1.000	1.000	10.000	3.157	6.843	2°	4
WEX21250EW	●	1.250	1.250	4.531	2.250	2.281	1°30'	5

WEX 2000 Endmill (Standard)

Catalog Number	Stock	Dimensions (mm)					Ramp Angle	Insert Qty.
		D	d	L	ℓ ₁	ℓ ₂		
WEX2014E	★	14	16	80	25	55	5°	1
WEX2016E	★	16	16	100	25	75	4°	2
WEX2018E	★	18	16	100	25	75	4°	2
WEX2020E	★	20	20	110	30	80	4°	3
WEX2022E	★	22	20	110	30	80	4°	3
WEX2025E	★	25	25	120	35	85	2°	4
WEX2028E	★	28	25	120	35	85	1°30'	4
WEX2030E	★	30	25	120	35	85	1°30'	4
WEX2032E	★	32	32	130	40	90	1°30'	5
WEX2040E	★	40	32	150	30	120	1°	6
WEX2050E	★	50	32	150	30	120	0°30'	7
WEX2063E	★	63	32	150	30	120	0°30'	8

WEX 2000 Endmill (Long Type)

Catalog Number	Stock	Dimensions (mm)					Ramp Angle	Insert Qty.
		D	d	L	ℓ ₁	ℓ ₂		
WEX2014EL	★	14	16	120	25	95	5°	1
WEX2016EL	●	16	16	145	25	120	4°	2
WEX2018EL	★	18	16	145	25	120	4°	2
WEX2020EL	★	20	20	150	40	110	4°	2
WEX2022EL	★	22	20	150	30	120	4°	2
WEX2025EL	★	25	25	170	50	120	2°	2
WEX2028EL	★	28	25	170	30	140	1°30'	2
WEX2030EL	★	30	25	170	30	140	1°30'	2
WEX2032EL	★	32	32	180	60	120	1°30'	2
WEX2040EL	★	40	32	180	30	150	1°	2

★ Worldwide Warehouse item

WEX2000 Inserts

Insert	P		K		M		S		N		Dimensions (Inches)				
	ACP100	ACP200	ACP300	ACK200	ACK300	ACM200	ACM300	DL1000	H1	L	W	T	R	Facet Width	
AXMT123504PEERG	●	●	●	●	●					.472	.260	.138	.016	.061	
AXMT123504PEERH	●	●	●	●	●					.472	.260	.138	.016	.061	
AXMT123508PEERG	●	●	●	●	●					.472	.260	.138	.031	.061	
AXMT123508PEERH	●	●	●	●	●					.472	.260	.138	.031	.061	
AXMT123512PEERG	●	●	●	●	●					.472	.260	.138	.047	.061	
AXMT123512PEERH	●	●	●	●	●					.472	.260	.138	.047	.061	
AXMT123504PEERE						●	●			.472	.260	.138	.016	.061	
AXMT123508PEERE						●	●			.472	.260	.138	.031	.061	
AXMT123508PEEREH						●	●			.472	.260	.138	.031	.061	
AXMT123512PEERE						●	●			.472	.260	.138	.047	.061	
AXMT123516PEERE						●	●			.472	.260	.138	.063	.061	
AXMT123524PEERE						●	●			.472	.260	.138	.094	.061	
AXMT123532PEERE						●	●			.472	.260	.138	.126	.061	
AXET123502PEFRS								●	●	.472	.260	.138	.008	.061	
AXET123504PEFRS								●	●	.472	.260	.138	.016	.061	
AXET123508PEFRS								●	●	.472	.260	.138	.031	.061	

Hardware

Inch Cutters	Metric Cutters	Insert Screw	Insert Wrench
WEX20500-WEX20625	WEX2014-WEX2018	BFTX0305IP	TRDR08IP
WEX20750-WEX21250	WEX2020-WEX2063	BFTX0306IP	TRDR08IP

* Torque specifications for insert screw=18-22 in/lbs.

See page 333
for recommended
running parameters

Max. Depth of Cut
AXMT12: 10mm (.394")

● USA stocked item



Indexable Milling
Shoulder Milling
Face Milling
High Feed Milling
Multi-purpose
Modular Tooling
UFO & SumiMill
Discontinued

Weldon Shank Series

Rake Angle	Radial	10° to 18°
	Axial	14° to 25°

10mm	0°
------	----

P	M	K	N	N	S	H
Steel	Stainless	Cast Iron	Inconel	Aluminum	Exotic Alloy	Titanium

Shell Mill Series

Rake Angle	Radial	16° to 18°
	Axial	23° to 25°

10mm	0°
------	----

P	M	K	N	N	S	H
Steel	Stainless	Cast Iron	Inconel	Aluminum	Exotic Alloy	Titanium

INCH & METRIC

WEX 2000

APPLICABLE INSERT:

AXMT
AXET

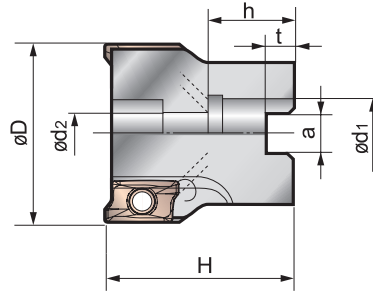

WEX 2000 Shell Mill (Inch)											
Catalog Number	Stock	Dimensions (inch)							Ramp Angle	Insert Qty.	
		D	d ₁	d ₂	a	t	H	h			
WEX21500R	●	1.500	0.750	0.406	0.312	0.187	1.562	0.750	2°	6	
WEX22000R	●	2.000	0.750	0.406	0.312	0.187	1.562	0.750	1°	7	
WEX22500R	●	2.500	1.000	0.531	0.375	0.218	1.562	0.750	0° 30'	8	

● USA stocked item

WEX 2000 Shell Mill (Metric)											
Catalog Number	Stock	Dimensions (mm)							Ramp Angle	Insert Qty.	
		D	d ₁	d ₂	a	t	H	h			
WEX2040F	★	40	16	9	8.4	5.6	40	18	2°	6	
WEX2050F	★	50	22	11	10.4	6.3	40	20	1°	7	
WEX2063F	★	63	22	11	10.4	6.3	40	20	0° 30'	8	

★ Worldwide Warehouse item

WEX2000 Inserts

Insert	P		K		M		S		N		Dimensions (Inches)				
	ACP100	ACP200	ACP300	ACK200	ACK300	ACM200	ACM300	DL1000	H1						
	L	W	T	R	Facet Width										
AXMT123504PEERG	●	●	●	●	●					.472	.260	.138	.016	.061	
AXMT123504PEERH	●	●	●	●	●					.472	.260	.138	.016	.061	
AXMT123508PEERG	●	●	●	●	●					.472	.260	.138	.031	.061	
AXMT123508PEERH	●	●	●	●	●					.472	.260	.138	.031	.061	
AXMT123512PEERG	●	●	●	●	●					.472	.260	.138	.047	.061	
AXMT123512PEERH	●	●	●	●	●					.472	.260	.138	.047	.061	
AXMT123504PEERE						●	●			.472	.260	.138	.016	.061	
AXMT123508PEERE						●	●			.472	.260	.138	.031	.061	
AXMT123508PEEREH						●	●			.472	.260	.138	.031	.061	
AXMT123512PEERE						●	●			.472	.260	.138	.047	.061	
AXMT123516PEERE						●	●			.472	.260	.138	.063	.061	
AXMT123524PEERE						●	●			.472	.260	.138	.094	.061	
AXMT123532PEERE						●	●			.472	.260	.138	.126	.061	
AXET123502PEFRS								●	●	.472	.260	.138	.008	.061	
AXET123504PEFRS								●	●	.472	.260	.138	.016	.061	
AXET123508PEFRS								●	●	.472	.260	.138	.031	.061	

Max. Depth of Cut
AXMT12: 10mm (.394")

● USA stocked item

Hardware

Inch Cutters	Metric Cutters	Insert Screw	Insert Wrench
WEX21500-WEX22500	WEX2040-WEX2063	BFTX0306IP	TRDR08IP

* Torque specifications for insert screw=18-22 in/lbs.

Coolant Through Bolts

Catalog Number	Cutter Size
BFXH 3/8 x 1	2.00"
BFXH 1/2 x 1 1/4	2.50"
BFXH 1/2 x 1 1/4	3.00"
BFXH 5/8 x 1 1/4	4.00"
BFXH 3/4 x 1 1/2	5.00"

Modifications to the cutter body is required when using inserts with large nose radius (R2.0 & larger)

Modifications to be done on this corner edge.



See page 333 for recommended running parameters



Indexable Milling

Shoulder Milling

Face Milling

High Feed Milling

Multi-purpose

Modular Tooling

UFO & SumiMill

Discontinued

INCH

WEX 3000

APPLICABLE INSERT:

AXMT
AXET

METRIC

WEX 3000

APPLICABLE INSERT:

AXMT
AXET

EXPANSION!
SEE BELOW

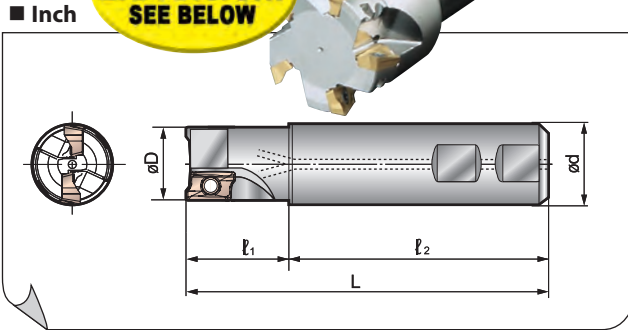

■ Metric

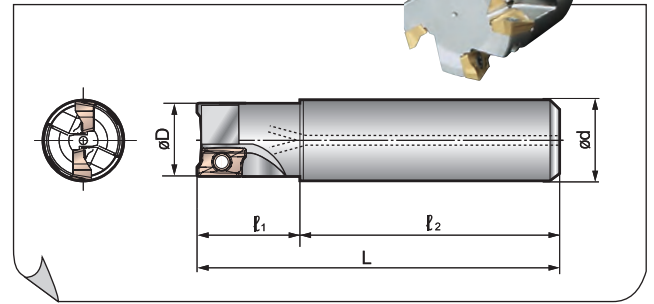

WEX 3000 Endmill

Catalog Number	Stock	Dimensions (inch)					Ramp Angle	Insert Qty.
		D	d	L	l ₁	l ₂		
WEX31000EW	●	1.000	1.000	3.811	1.530	2.281	5°	2
WEX31000EMW	●	1.000	1.000	4.841	2.560	2.281	5°	2
WEX31000ELW	●	1.000	1.000	6.341	4.060	2.281	5°	2
WEX31000ELC	●	1.000	1.000	10.000	3.137	6.863	5°	2
WEX31250EW	●	1.250	1.250	4.531	2.250	2.281	3°	3
WEX31250EMW	●	1.250	1.250	6.381	4.100	2.281	3°	3
WEX31250ELC	●	1.250	1.250	10.000	3.149	6.851	3°	3
WEX31500EMW	●	1.500	1.250	6.421	4.140	2.281	2°	3
WEX31500EW	●	1.500	1.250	4.531	2.250	2.281	2°	4
WEX31500ELC	●	1.500	1.250	10.000	3.000	7.000	2°	4
WEX32000EW	●	2.000	1.250	4.531	2.250	2.281	2°	5

● USA stocked item

WEX 3000 Endmill (Standard)

Catalog Number	Stock	Dimensions (mm)					Ramp Angle	Insert Qty.
		D	d	L	l ₁	l ₂		
WEX3025E	★	25	25	120	35	85	5°	2
WEX3032E	★	32	32	130	40	90	3°	3
WEX3040E	★	40	32	170	50	120	2°	4
WEX3050E	★	50	32	170	50	120	1°	5
WEX3063E	★	63	32	170	50	120	0°30'	6

WEX 3000 Endmill (Short Type)

Catalog Number	Stock	Dimensions (mm)					Ramp Angle	Insert Qty.
		D	d	L	l ₁	l ₂		
WEX3050ES	★	50	32	135	25	110	1°	5
WEX3063ES	★	63	32	135	25	110	0°30'	6

WEX 3000 Endmill (Long Type)

Catalog Number	Stock	Dimensions (mm)					Ramp Angle	Insert Qty.
		D	d	L	l ₁	l ₂		
WEX3025EL	★	25	25	170	50	120	5°	2
WEX3028EL	★	28	25	170	50	120	5°	2
WEX3030EL	★	30	25	180	60	120	5°	2
WEX3032EL	★	32	32	180	60	120	3°	2
WEX3035EL	★	35	32	180	60	120	2°	2
WEX3040EL	★	40	32	220	80	140	2°	2

WEX 3000 Endmill (Coarse Pitch)

Catalog Number	Stock	Dimensions (mm)					Ramp Angle	Insert Qty.
		D	d	L	l ₁	l ₂		
WEX3040E-C	★	40	32	170	50	120	2°	3
WEX3050E-C	★	50	32	170	50	120	1°	3
WEX3063E-C	★	63	32	180	50	120	0°30'	4

WEX 3000 Endmill (Coarse Pitch & Short Type)

Catalog Number	Stock	Dimensions (mm)					Ramp Angle	Insert Qty.
		D	d	L	l ₁	l ₂		
WEX3050ES-C	★	50	32	135	25	110	1°	3
WEX3063ES-C	★	63	32	135	25	110	0°30'	4

★ Worldwide Warehouse item

WEX3000 Inserts

Insert	Material						Dimensions (Inches)						
	P	K	M	S	N	H1	Diagram						
	ACP100	ACP200	ACP300	ACK200	ACK300	ACM200	ACM300	DL1000	L	W	T	R	Facet Width
AXMT170504PEERG	●	●	●	●	●				.689	.402	.219	.016	.118
AXMT170508PEERG	●	●	●	●	●				.689	.402	.219	.031	.118
AXMT170508PEERH	●	●	●	●	●				.689	.402	.219	.031	.118
AXMT170508PEERL	●	●	●	●	●				.689	.402	.219	.031	.118
AXMT170512PEERG	●	●	●	●	●				.689	.402	.219	.047	.118
AXMT170512PEERH	●	●	●	●	●				.689	.402	.219	.047	.118
AXMT170516PEERG	●	●	●	●	●				.689	.402	.219	.063	.118
AXMT170520PEERG	●	●	●	●	●				.689	.402	.219	.079	.118
AXMT170530PEERG	●	●	●	●	●				.689	.402	.219	.118	.118
AXMT170532PEERG	●								.689	.402	.219	.126	.118
AXMT170504PEERE						●	●		.689	.402	.219	.016	.118
AXMT170508PEERE						●	●		.689	.402	.219	.031	.118
AXMT170508PEEREH						●	●		.689	.402	.219	.031	.118
AXMT170512PEERE						●	●		.689	.402	.219	.047	.118
AXMT170516PEERE						●	●		.689	.402	.219	.063	.118
AXMT170520PEERE						●	●		.689	.402	.219	.079	.118
AXMT170524PEERE						●	●		.689	.402	.219	.094	.118
AXMT170530PEERE						●	●		.689	.402	.219	.118	.118
AXMT170531PEERE						●	●		.689	.402	.219	.122	.118
AXMT170548PEERE	●			●	●	●			.689	.402	.219	.189	.118
AXMT170563PEERE				●	●	●			.689	.402	.219	.248	.118
AXET170502PEFRS						●	●		.689	.402	.219	.008	.118
AXET170504PEFRS						●	●		.689	.402	.219	.016	.118
AXET170508PEFRS						●	●		.689	.402	.219	.031	.118

Max. Depth of Cut
AXMT17: 14mm (.551")

● USA stocked item

Hardware

Inch Cutters	Metric Cutters	Insert Screw	Insert Wrench
WEX31000	WEX3025	BFTX04071P	TRDR151P
WEX31250-WEX32000	WEX3032-WEX3063	BFTX04091P	TRDR081P

* Torque specifications for insert screw=27-31 in/lbs.



Rake Angle	Radial	8° to 15°	14mm	0°
Angle	Axial	16° to 24°		

P	M	K	N	N	S	H
Steel	Aluminum	Cast Iron	Inconel	Aluminum	Tool/Alloy	Inconel

Rake Angle	Radial	12° to 15°	14mm	0°
Angle	Axial	19° to 24°		

P	M	K	N	N	S	H
Steel	Aluminum	Cast Iron	Inconel	Aluminum	Tool/Alloy	Inconel

WEX 3000

AXMT
AXET

WEX 3000 Shell Mill (Inch)

Catalog Number	Stock	Dimensions (inch)							Ramp Angle	Insert Qty.	Figure
		D	d ₁	d ₂	a	t	H	h			
WEX32000R	●	2.000	0.750	0.406	0.312	0.187	1.562	0.750	1°	5	1
WEX32500R	●	2.500	1.000	0.531	0.375	0.218	1.562	0.750	0° 30'	6	1
WEX33000R	●	3.000	1.000	0.531	0.375	0.218	1.750	0.750	0° 30'	5	1
WEX33000R	●	3.000	1.000	0.531	0.375	0.218	1.750	0.750	0° 30'	7	1
WEX34000R	●	4.000	1.250	0.656	0.500	0.281	1.750	0.750	N/A	6	1
WEX34000R-150	●	4.000	1.500	0.781	0.625	0.380	2.000	1.535	N/A	6	1
WEX34000R	●	4.000	1.250	0.656	0.500	0.281	2.461	0.750	N/A	8	1
WEX34000R-150	●	4.000	1.500	0.781	0.625	0.380	2.000	1.535	N/A	8	1
WEX36000R	●	6.000	1.500	1.500	0.625	0.380	2.500	1.060	N/A	8	1
WEX38000R	●	8.000	2.500	2.500	1.000	0.560	2.500	1.250	N/A	12	2

WEX 3000 Shell Mill Standard Type (Metric)

Catalog Number	Stock	Dimensions (mm)							Ramp Angle	Insert Qty.
		D	d ₁	d ₂	a	t	H	h		
WEX3040F	★	40	16	9	8.4	5.6	40	18	2°	4
WEX3050F	★	50	22	11	10.4	6.3	40	20	1°	5
WEX3063F	★	63	22	11	10.4	6.3	40	20	0° 30'	6
WEX3080F	★	80	25.4	13	9.5	6.0	50	25	0° 30'	4
WEX3100F	★	100	31.75	-	12.7	8.0	63	-	N/A	5
WEX3125F	★	125	38.10	-	15.9	10.0	63	-	N/A	6

WEX 3000 Shell Mill Fine Pitch (Metric)

Catalog Number	Stock	Dimensions (mm)							Ramp Angle	Insert Qty.
		D	d ₁	d ₂	a	t	H	h		
WEX3080R	★	80	25.40	13	9.5	6	50	25	0° 30'	7
WEX3100R	★	100	31.75	-	12.7	8	63	-	N/A	8
WEX3125R	★	125	38.10	-	15.9	10	63	-	N/A	9

WEX3000 Inserts

Insert	Dimensions (Inches)							Facet Width			
	P	K	M	S	N	H1	L	W	T	R	Facet Width
	ACP100	ACP200	ACP300	ACK200	ACK300	ACM200	ACM300	DL1000			
AXMT170504PEERG	●	●	●	●	●		.689	.402	.219	.016	.118
AXMT170508PEERG	●	●	●	●	●		.689	.402	.219	.031	.118
AXMT170508PEERH	●	●	●	●	●		.689	.402	.219	.031	.118
AXMT170508PEERL	●	●	●	●	●		.689	.402	.219	.031	.118
AXMT170512PEERG	●	●	●	●	●		.689	.402	.219	.047	.118
AXMT170512PEERH	●	●	●	●	●		.689	.402	.219	.047	.118
AXMT170516PEERG	●	●	●	●	●		.689	.402	.219	.063	.118
AXMT170520PEERG	●	●	●	●	●		.689	.402	.219	.079	.118
AXMT170530PEERG	●	●	●	●	●		.689	.402	.219	.118	.118
AXMT170532PEERG	●	●	●	●	●		.689	.402	.219	.126	.118
AXMT170504PEERE						●	.689	.402	.219	.016	.118
AXMT170508PEERE						●	.689	.402	.219	.031	.118
AXMT170508PEEREH						●	.689	.402	.219	.031	.118
AXMT170512PEERE						●	.689	.402	.219	.047	.118
AXMT170516PEERE						●	.689	.402	.219	.063	.118
AXMT170520PEERE						●	.689	.402	.219	.079	.118
AXMT170524PEERE						●	.689	.402	.219	.094	.118
AXMT170530PEERE						●	.689	.402	.219	.118	.118
AXMT170531PEERE						●	.689	.402	.219	.122	.118
AXMT170548PEERE	●			●	●	●	.689	.402	.219	.189	.118
AXMT170563PEERE						●	.689	.402	.219	.248	.118
AXET170502PEFRS						●	.689	.402	.219	.008	.118
AXET170504PEFRS						●	.689	.402	.219	.016	.118
AXET170508PEFRS						●	.689	.402	.219	.031	.118

● USA stocked item



Fig 1

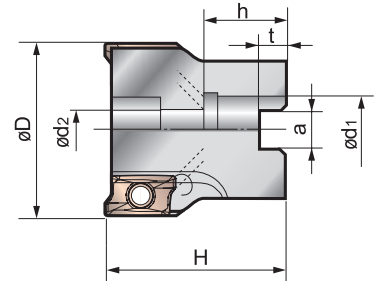
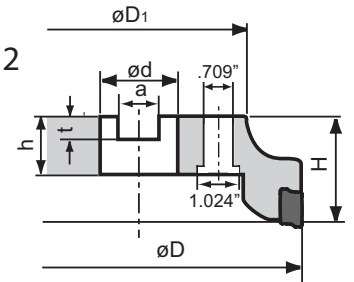

Fig 2



● USA stocked item

★ Worldwide Warehouse item

Hardware

Inch Cutters	Metric Cutters	Insert Screw	Insert Wrench
WEX32000-WEX34000	WEX3040-WEX3125	BFTX0409IP	TRDR15IP

* Torque specifications for insert screw=27-31 in/lbs.

Coolant Through Bolts

Catalog Number	Cutter Size
BFXH 3/8 x 1	2.00"
BFXH 1/2 x 1 1/4	2.50"
BFXH 1/2 x 1 1/4	3.00"
BFXH 5/8 x 1 1/4	4.00"
BFXH 3/4 x 1 1/2	5.00"

Modifications to the cutter body is required when using inserts with large nose radius (R2.0 & larger)

Modifications to be done on this corner edge.



Max. Depth of Cut
AXMT17: 14mm (.551")
● USA stocked item



Indexable Milling
Shoulder Milling
Face Milling
High Feed Milling
Multi-purpose
Modular Tooling
UFO & SumiMill
Discontinued



Features & Benefits

- Long cutting edges are arranged in multiple stages to enable high efficiency milling
- Optimized cutting positions provide low cutting resistance and low vibration
- Dual level cutting edge design reduces number of passes
- Lead groove and special pocket shape offer smooth chip evacuation and high body rigidity
- Low edge supporting face reduces bottom edge breakage and provides high reliability

Cutting Resistance

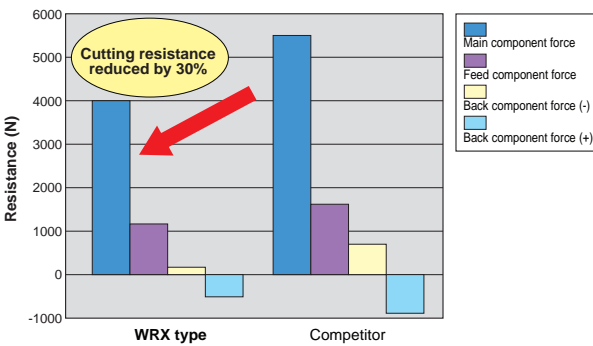

Material: Medium carbon steel
 Tool: WRX2025E2725
 SFM=330 IPT=0.006 Cutting Width=0.394
 D.O.C.=1.000 Dry

Vibration Comparison



Material: Medium carbon steel
 Tool: WRX3080RS5332
 SFM=490 IPT=0.008 Cutting Width=0.197
 D.O.C.=1.575 Dry

Special Tooling

Integrated Arbor

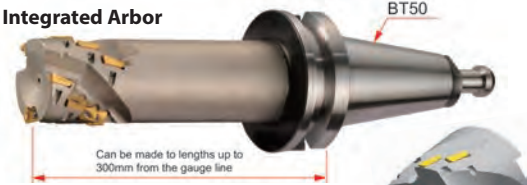

Unique Clamping Design

- 1) Unique clamping combines spigot and drive
- 2) Easy position adjustment minimizes deterioration of run-out precision
- 3) Available as an integrated unit with an arbor

Indexable Head

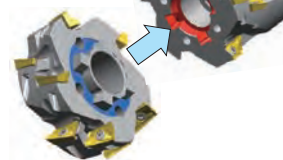

Dual Level cutting edge design reduces number of passes

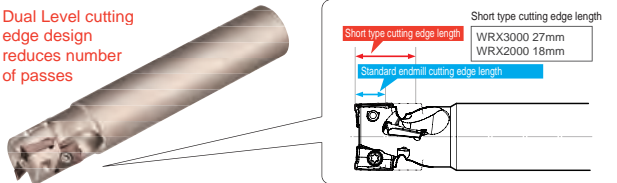

Characteristics

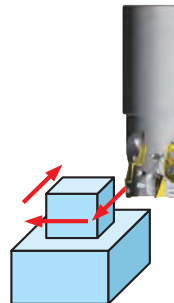
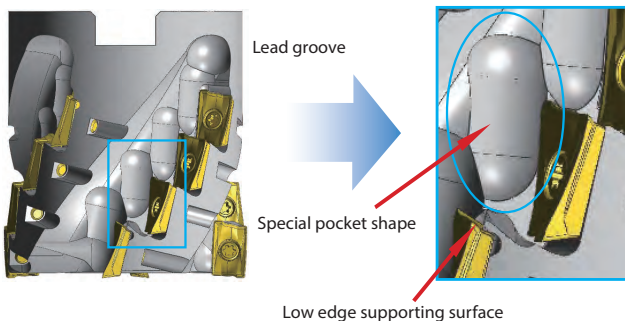

Application Example

Part/ Work Material	Stainless Steel Part		
	Manufacturer	Sumitomo	Competitor
Tool	Body	WRX3040E4042	ø40
	Insert	AXMT170508PEERG	0.59 in (15mm)
	Grade	ACP300	PVD
	Tool Dia. in (mm)	1.57 (40)	40
	Total Teeth	9	6
Conditions	Effective Teeth	3	2
	Cutting Speed	4.92 sfm (125mm/min)	4.92 sfm (125mm/min)
	Feed	0.008 ipt (0.2 mm/t)	0.008 ipt (0.2 mm/t)
	Axial Cutting Depth	1.575 in (40mm)	1.575 in (40mm)
	Radial Cutting Depth	0.1969 in (5mm)	0.1969 in (5mm)
Results	Dry/Wet	Wet	Wet
Results	Tool Life/ Corner	20	5 to 10
Evaluation	Stable machining with double the competitor's tool life and no breakage		



Recommended Cutting Conditions

Tool: WRX3050E5342 Insert: AXMT170508PEER-G
 D.O.C. = 1.969 in. (50 mm)
 Cutting Width = 0.3937 in. (10 mm)
 Dry

Classification	Work Material	Hardness (HB)	Chipbreaker	Grades																							
				ACP100			ACP200			ACP300			ACK200			ACK300			DL1000			ACM 200			ACM300		
				Feed Rate - IPT (mm/tooth)																							
				.004	.006	.008	.004	.006	.008	.004	.006	.008	.004	.006	.008	.004	.006	.008	.004	.006	.008	.004	.006	.008	.004	.006	.008
Cutting Speed - SFM (m/min)																											
P	Carbon steel	125	G	1049 (320)	984 (300)	918 (280)	984 (300)	918 (280)	853 (260)	918 (280)	853 (260)	787 (240)															
		190	G	787 (240)	721 (220)	656 (200)	721 (220)	656 (200)	590 (180)	656 (200)	590 (180)	524 (160)															
	Hardened carbon steel	250	G	656 (200)	590 (180)	524 (160)	590 (180)	524 (160)	459 (140)	524 (160)	459 (140)	393 (120)															
		270	G	524 (160)	459 (140)	393 (120)	492 (150)	426 (130)	360 (110)	426 (130)	360 (110)	328 (100)															
		300	G	393 (120)	328 (100)	262 (80)	328 (100)	262 (80)	196 (60)	262 (80)	196 (60)	164 (50)															
	Low alloy steel	180	G	721 (220)	656 (200)	590 (180)	656 (200)	590 (180)	557 (170)	590 (180)	557 (170)	492 (150)															
	Hardened alloy steel	275	G	459 (140)	393 (120)	328 (100)	426 (130)	360 (110)	328 (100)	360 (110)	328 (100)	262 (80)															
		300	G	426 (130)	360 (110)	295 (90)	360 (110)	295 (90)	262 (80)	328 (100)	262 (80)	196 (60)															
		350	G	341 (104)	262 (80)	209 (64)	288 (88)	236 (72)	183 (56)	236 (72)	183 (56)	131 (40)															
	High alloy steel	200	G	656 (200)	590 (180)	524 (160)	590 (180)	524 (160)	459 (140)	524 (160)	459 (140)	393 (120)															
Hardened high alloy steel	325	G	328 (100)	262 (80)	196 (60)	262 (80)	196 (60)	164 (50)	196 (60)	164 (50)	98 (30)																
M	Stainless Steel 300 Series	200	G	582 SFM	517 SFM	451 SFM	484 SFM	451 SFM	385 SFM	451 SFM	385 SFM	353 SFM												625 SFM	575 SFM	525 SFM	
		240	G	484 SFM	418 SFM	353 SFM	418 SFM	353 SFM	320 SFM	353 SFM	320 SFM	254 SFM													580 SFM	525 SFM	480 SFM
		180	G	615 SFM	549 SFM	484 SFM	549 SFM	484 SFM	451 SFM	484 SFM	451 SFM	385 SFM													650 SFM	600 SFM	550 SFM
	Precipitation Hardening	>240																						300 ~ 800 SFM	275 ~ 775 SFM	250 ~ 750 SFM	
K	Cast iron	200	G										787 (240)	721 (220)	656 (200)	721 (220)	656 (200)	590 (180)									
	Nodular cast iron	280	G										524 (160)	459 (140)	393 (120)	459 (140)	393 (120)	328 (100)									
S	Super alloys		G										164 (50)	98 (30)		164 (50)	98 (30)										
N	Aluminum alloys																										

Indexable Milling
Shoulder Milling
Face Milling
High Feed Milling
Multi-purpose
Modular Tooling
UFO & SumiMill
Discontinued



WRX SERIES

Rake Angle	Radial	13° to 16°
	Axial	16° to 24°

18 to 36mm 0°



Weldon

Rake Angle	Radial	16° to 17°
	Axial	24°

18 to 36mm 0°



Shell

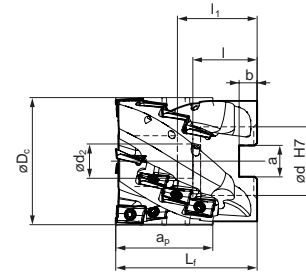
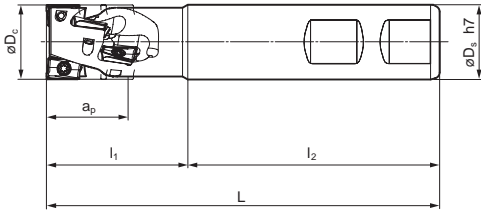

WRX2000 Endmill Cutter Bodies - Weldon Shank - INCH

Catalog Number	Stock	Dimensions (inch)						Steps	Effective Teeth	Total Teeth	Weight lbs (kg)
		ϕD_c	ϕD_s	L	I_1	I_2	a_p				
WRX21000E100-150	●	1.000	1.000	4.250	1.950	2.300	1.500	4	2	8	1.10 (0.5)
WRX21250E125-175	●	1.250	1.250	4.500	2.200	2.300	1.750	5	3	15	1.48 (0.7)
WRX21500E125-200	●	1.500	1.250	4.800	2.500	2.300	2.126	6	4	24	1.82 (0.8)

WRX2000 Shell Mill Cutter Bodies - METRIC

Catalog Number	Stock	Dimensions (mm)									Steps	Effective Teeth	Total Teeth	Weight lbs (kg)
		ϕD_c	ϕd	ϕd_2	L_1	L_2	a	b	a_p					
WRX2040RS1816*	★	40	16	9	50	28	18	8.4	5.6	18	2	5	10	0.66 (0.3)
WRX2040RS3616	★	40	16	9	55	28	18	8.4	5.6	36	4	4	16	1.10 (0.5)
WRX2050RS1822*	★	50	22	11	50	26	20	10.4	6.3	18	2	5	10	0.88 (0.4)
WRX2050RS3622	★	50	22	11	55	26	20	10.4	6.3	36	4	4	16	1.10 (0.5)

WRX2000 Endmill Cutter Bodies - METRIC

Catalog Number	Stock	Dimensions (mm)						Steps	Effective Teeth	Total Teeth	Weight lbs (kg)
		ϕD_c	ϕD_s	L	I_1	I_2	a_p				
WRX2020E1820*	★	20	20	120	40	80	18	2	2	4	0.66 (.03)
WRX2020E3620	★	20	20	130	45	85	36	4	1	4	0.66 (.03)
WRX2025E1825*	★	25	25	130	45	85	18	2	3	6	0.88 (.04)
WRX2025E2725	★	25	25	130	45	85	27	3	2	6	0.88 (.04)
WRX2032E1832*	★	32	32	140	50	90	18	2	4	8	1.76 (.08)
WRX2032E2732	★	32	32	130	45	85	27	3	3	9	1.54 (.07)
WRX2040E1832*	★	40	32	160	40	120	18	2	5	10	2.43 (1.1)
WRX2040E3642	★	40	42	130	45	85	36	4	4	16	2.65 (1.2)

Hardware

Wrench	Screw
TRDR08IP	BFTX0306IP

WEX2000 Inserts

Insert	Material						Dimensions (Inches)							
	P	K	M	S	N	Diagram								
	ACP100	ACP200	ACP300	ACK200	ACK300	ACM200	ACM300	DL1000	H1	L	W	T	R	Facet Width
	●	●	●	●	●									
AXMT123504PEERG	●	●	●	●	●					.472	.260	.138	.016	.061
AXMT123504PEERH	●	●	●	●	●					.472	.260	.138	.016	.061
AXMT123508PEERG	●	●	●	●	●					.472	.260	.138	.031	.061
AXMT123508PEERH	●	●	●	●	●					.472	.260	.138	.031	.061
AXMT123512PEERG	●	●	●	●	●					.472	.260	.138	.047	.061
AXMT123512PEERH	●	●	●	●	●					.472	.260	.138	.047	.061
AXMT123504PEERE						●	●			.472	.260	.138	.016	.061
AXMT123508PEERE						●	●			.472	.260	.138	.031	.061
AXMT123508PEEREH						●	●			.472	.260	.138	.031	.061
AXMT123512PEERE						●	●			.472	.260	.138	.047	.061
AXMT123516PEERE						●	●			.472	.260	.138	.063	.061
AXMT123524PEERE						●	●			.472	.260	.138	.094	.061
AXMT123532PEERE						●	●			.472	.260	.138	.126	.061
AXET123502PEFRS								●	●	.472	.260	.138	.008	.061
AXET123504PEFRS								●	●	.472	.260	.138	.016	.061
AXET123508PEFRS								●	●	.472	.260	.138	.031	.061

Max. Depth of Cut
AXMT12: 10mm (.394")

• USA stocked item

See page 339
for recommended
running parameters



Weldon	Rake Angle	Radial	12° to 13°		
		Axial	20° to 22°		
Shell	Rake Angle	Radial	13° to 15°		
		Axial	22° to 24°		

WRX SERIES

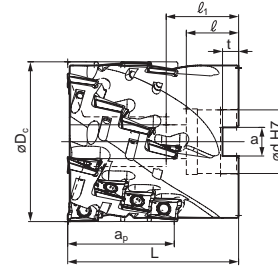
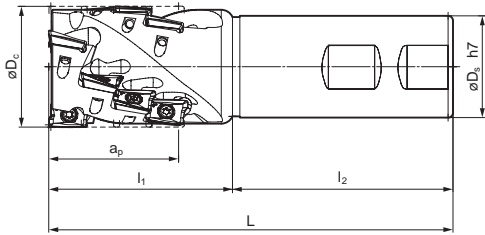

WRX3000 Endmill Cutter Bodies - Weldon Shank - INCH											
Catalog Number	Stock	Dimensions (inch)						Steps	Effective Teeth	Total Teeth	Weight lbs (kg)
		ϕD_c	ϕD_s	L	l_1	l_2	a_p				
WRX32000E125-250	●	2.000	1.250	5.000	2.700	2.300	2.500	5	3	15	2.56 (1.2)

WRX3000 Shell Mill Cutter Bodies - INCH												
Catalog Number	Stock	Dimensions (inch)						Steps	Effective Teeth	Total Teeth	Weight lbs (kg)	
		ϕD_c	ϕD_s	L	l_1	b	a_p					a
WRX32500R100-250	●	2.500	1.000	2.750	1.023	0.236	2.500	0.375	5	4	20	3.42 (1.6)
WRX33000R125-300	●	3.000	1.250	3.375	1.260	0.315	3.000	0.500	6	5	30	6.24 (2.8)

WRX3000 Endmill Cutter Bodies - METRIC											
Catalog Number	Stock	Dimensions (mm)						Steps	Effective Teeth	Total Teeth	Weight lbs (kg)
		ϕD_c	ϕD_s	L	l_1	l_2	a_p				
WRX3040E2732*	★	40	32	180	60	120	27	2	3	6	2.65 (1.2)
WRX3040E4042	★	40	42	150	65	85	40	3	3	9	2.87 (1.3)
WRX3050E2732*	★	50	32	180	60	120	32	2	4	8	3.09 (1.4)
WRX3050E5342	★	50	42	165	75	90	53	4	3	12	3.97 (1.8)

WRX3000 Shell Mill Cutter Bodies - METRIC														
Catalog Number	Stock	Dimensions (mm)						Steps	Effective Teeth	Total Teeth	Weight lbs (kg)			
		ϕD_c	ϕd	ϕd_2	L_1	l_1	l					a	b	a_p
WRX3050RS2722*	★	50	22	11	50	26	20	10.4	6.3	27	2	4	8	0.88 (.04)
WRX3050RS5322	★	50	22	11	70	26	20	10.4	6.3	53	4	3	12	1.32 (.06)
WRX3063RS2722*	★	63	22	11	50	26	20	10.4	6.3	27	2	5	10	1.54 (.07)
WRX3063RS5327	★	63	27	13.5	70	30	23	12.4	7	53	4	4	16	2.20 (1.0)
WRX3080R27254*	★	80	25.4	13	50	31	25	9.5	6	27	2	6	12	2.43 (1.1)
WRX3080RS5332	★	80	32	17	85	36	26	14.4	8	53	4	5	20	4.85 (2.2)
WRX3100R27317*	★	100	31.75	17	63	39.5	32.5	12.7	8	27	2	7	14	4.41 (2.0)
WRX3100RS5340	★	100	40	21	85	36	30	16.4	9.5	53	4	6	24	7.72 (3.5)

WEX3000 Inserts

Insert	Material					Dimensions (Inches)				
	P	K	M	S	N	L	W	T	R	Facet Width
	ACP100	ACP200	ACP300	ACK200	ACK300					
AXMT170504PEERG	●	●	●	●	●	.689	.402	.219	.016	.118
AXMT170508PEERG	●	●	●	●	●	.689	.402	.219	.031	.118
AXMT170508PEERH	●	●	●	●	●	.689	.402	.219	.031	.118
AXMT170508PEERL	●	●	●	●	●	.689	.402	.219	.031	.118
AXMT170512PEERG	●	●	●	●	●	.689	.402	.219	.047	.118
AXMT170512PEERH	●	●	●	●	●	.689	.402	.219	.047	.118
AXMT170516PEERG	●	●	●	●	●	.689	.402	.219	.063	.118
AXMT170520PEERG	●	●	●	●	●	.689	.402	.219	.079	.118
AXMT170530PEERG	●	●	●	●	●	.689	.402	.219	.118	.118
AXMT170532PEERG	●	●	●	●	●	.689	.402	.219	.126	.118
AXMT170504PEERE				●	●	.689	.402	.219	.016	.118
AXMT170508PEERE				●	●	.689	.402	.219	.031	.118
AXMT170508PEEREH				●	●	.689	.402	.219	.031	.118
AXMT170512PEERE				●	●	.689	.402	.219	.047	.118
AXMT170516PEERE				●	●	.689	.402	.219	.063	.118
AXMT170520PEERE				●	●	.689	.402	.219	.079	.118
AXMT170524PEERE				●	●	.689	.402	.219	.094	.118
AXMT170530PEERE				●	●	.689	.402	.219	.118	.118
AXMT170531PEERE				●	●	.689	.402	.219	.122	.118
AXMT170548PEERE				●	●	.689	.402	.219	.189	.118
AXMT170563PEERE				●	●	.689	.402	.219	.248	.118
AXET170502PEFRS					●	.689	.402	.219	.008	.118
AXET170504PEFRS					●	.689	.402	.219	.016	.118
AXET170508PEFRS					●	.689	.402	.219	.031	.118

Hardware

Wrench TRDR15IP	Screw BFTX0409IP

● = USA Stocked Item ★ = Worldwide Warehouse Item

*Short Cutting Edge Type

**See page 339
for recommended
running parameters**

● USA stocked item

Max. Depth of Cut
AXMT17: 14mm (.551")



Indexable Milling
Shoulder Milling
Face Milling
High Feed Milling
Multi-purpose
Modular Tooling
UFO & SumiMill
Discontinued

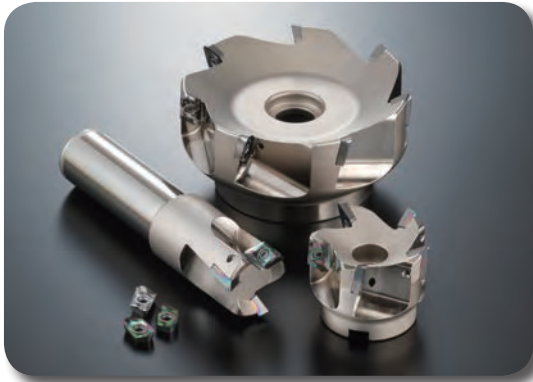

Features & Benefits

WAX WaveMill cutters are high speed and high efficiency endmills capable of rough milling to finishing of non-ferrous metals such as Aluminium alloys.

■ Characteristics

- Ideal for ramping (slant milling) and helical milling
- Safety-oriented design prevents dislodging of inserts caused by centrifugal forces
- Coolant holes are a standard feature for the WAX series
- Excellent adhesion resistance
- Top rake face of the insert has a polished finish
- DLC Coat inserts are available for improved adhesion resistance

■ Ramping (Slant Milling)

Maximum ramping angle (α° max.) depends on cutter diameter. Minimum milling length (L min) is the ramping distance required to reach the maximum cutting depth (a_p max) at the maximum ramping angle of that cutter.

Minimum milling length (L) for any depth can be calculated by the equation below:

$$L = \frac{a_p}{\tan \alpha} \text{ (mm)}$$

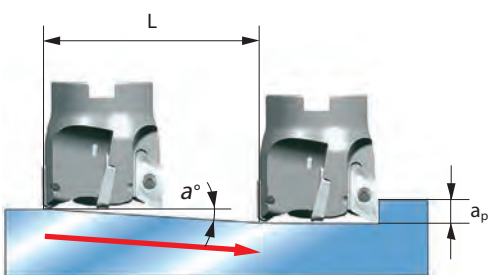

■ Ramping (Slant Milling) Angles

Cutter Diameter ϕD_c (mm)	Max. Ramping Angle α° max	
	WAX3000 Type	WAX4000 Type
20	8°	
25	17°	6°
32	12°	18°30'
40	9°	13°
50	7°	9°30'
63	5°	7°
80	3°	5°
100	3°	4°
125	2°	3°

■ Helical Milling

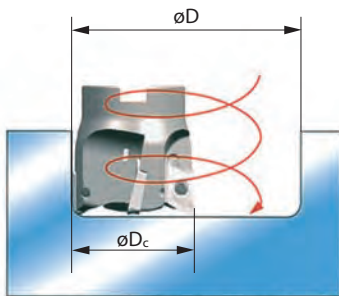

■ Helical Milling Diameter

Cutter Diameter ϕD_c (mm)	WAX3000 Type		WAX4000 Type	
	Minimum Diameter	Maximum Diameter	Minimum Diameter	Maximum Diameter
20	22	33		
25	29	43	24	43
32	43	57	38	57
40	59	73	54	73
50	79	93	74	93
63	105	119	100	119
80	139	153	134	153
100	179	193	174	193
125	229	243	224	243

Max. Allowable Spindle Speed

Cutter Diameter ϕD_c (mm)	WAX3000 Type		WAX4000 Type	
	n max(min ⁻¹)	v_c (m/min)	n max(min ⁻¹)	v_c (m/min)
20	14,000	880		
25	29,000	2,200	11,000	860
32	25,000	2,500	9,000	900
40	23,000	2,900	20,000	2,500
50	20,000	3,100	18,000	2,800
63	18,000	3,500	16,000	3,100
80	16,000	4,000	14,000	3,500
100	14,000	4,400	12,000	3,700
125	13,000	5,100	11,000	4,300

The n max speeds are set to prevent the inserts from dislodging by centrifugal forces.

Recommended Cutting Conditions

ISO	Work Material	Hardness	Cutting Speed v_c (m/min) Min.- Optimum -Max.	Feed Rate f_z (mm/t) Min.- Optimum -Max.	Grade
N	Aluminium Alloy	-	600-900-1200	0.05-0.15-0.25	DL1000



Indexable Milling
Shoulder Milling
Face Milling
High Feed Milling
Multi-purpose
Modular Tooling
UFO & SumiMill
Discontinued

WAX 3000 Series

Rake Angle	Radial	6°	16 to 18mm	0°
	Axial	19° to 25°		

P	M	K	N	S	H
Steel	Cast Iron	Cast Iron	High Speed Steel	Aluminum	Copper Alloy
X	X	X	X	X	X

WAX 4000 Series

Rake Angle	Radial	6°	22 to 24mm	0°
	Axial	19° to 25°		

P	M	K	N	S	H
Steel	Cast Iron	Cast Iron	High Speed Steel	Aluminum	Copper Alloy
X	X	X	X	X	X

WAX 3000/4000/INCH

Applicable Insert: AECT

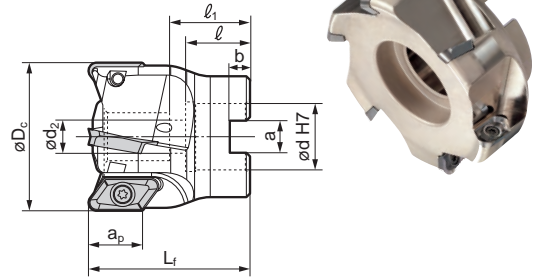
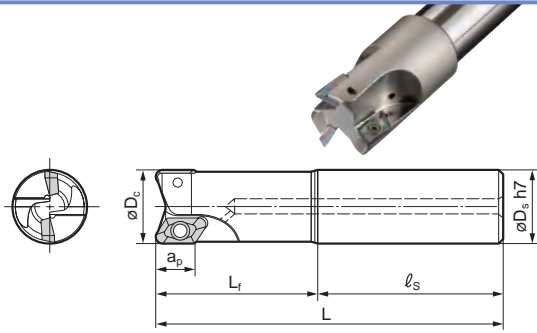

WAX 3000 Endmill Cutter Bodies - INCH						
Catalog Number	Dc	Ds	OAL	Lf	ls	No. of teeth
WAX30750EW-3.2	0.750	0.750	4.281	2.000	2.281	1
WAX30750ELC-3.2	0.750	0.750	8.000	2.000	6.000	1
WAX31000EW-3.2	1.000	1.000	4.781	2.500	2.281	2
WAX31000ELC-3.2	1.000	1.000	10.000	2.500	7.500	2
WAX31250EW-3.2	1.250	1.250	4.781	2.500	2.281	2
WAX31250ELC-3.2	1.250	1.250	10.000	2.500	7.500	2
WAX31500EW-3.2	1.500	1.500	4.781	2.500	2.281	3
WAX31500ELC-3.2	1.500	1.500	10.000	2.500	7.500	3
WAX30750EW-4.0	0.750	0.750	4.281	2.000	2.281	1
WAX30750EW-4.0	0.750	0.750	8.000	2.000	6.000	1
WAX31000EW-4.0	1.000	1.000	4.281	2.000	2.281	2
WAX31000ELC-4.0	1.000	1.000	10.000	2.500	7.500	2
WAX31250EW-4.0	1.250	1.250	4.781	2.500	2.281	2
WAX31250ELC-4.0	1.250	1.250	10.000	2.500	7.500	2
WAX31500EW-4.0	1.500	1.500	4.781	2.500	2.281	3
WAX31500ELC-4.0	1.500	1.500	10.000	2.500	7.500	4

WAX 3000 Shell Mill Cutter Bodies - INCH									
Catalog Number	φDc	Φd	φd2	φd1	L1	a	b	l	No. of teeth
WAX32000-3.2	2.000	0.750	0.406	0.630	1.750	0.312	0.220	0.787	4
WAX32500-3.2	2.500	1.000	0.531	0.630	1.750	0.375	0.220	0.787	5
WAX33000-3.2	3.000	1.000	0.531	1.260	2.000	0.375	0.248	0.866	5
WAX34000-3.2	4.000	1.250	0.656	1.220	2.500	0.500	0.394	1.181	6
WAX35000-3.2	5.000	1.500	0.656	1.220	2.500	0.625	0.394	1.181	7
WAX32000-4.0	2.000	0.750	0.406	0.630	1.750	0.312	0.220	0.787	4
WAX32500-4.0	2.500	1.000	0.531	0.630	1.750	0.375	0.220	0.787	4
WAX33000-4.0	3.000	1.000	0.531	1.260	2.000	0.375	0.248	0.866	5
WAX34000-4.0	4.000	1.250	0.656	1.220	2.500	0.500	0.394	1.181	6
WAX35000-4.0	5.000	1.500	0.656	1.220	2.500	0.625	0.394	1.181	7

All WAX inch size cutters and applicable inserts are USA stocked items (please see page 344 for inserts).
 Holders with -3.2 suffix are for inserts with a radius of 3.2mm and below.
 Holders with -4.0 suffix are for inserts with a radius of 4.0mm and above.

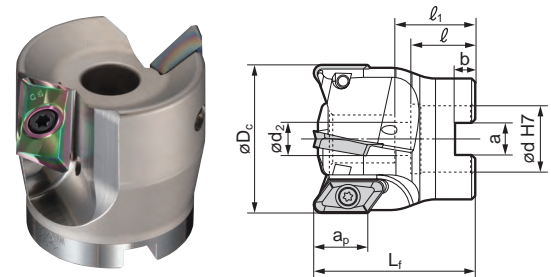
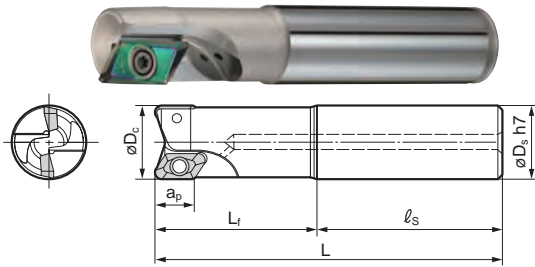

WAX 4000 Endmill Cutter Bodies - INCH						
Catalog Number	Dc	Ds	OAL	Lf	ls	No. of teeth
WAX41000EW-3.2	1.000	1.000	4.781	2.500	2.281	1
WAX41000ELC-3.2	1.000	1.000	10.000	2.500	7.500	1
WAX41250EW-3.2	1.250	1.250	4.781	2.500	2.281	1
WAX41250ELC-3.2	1.250	1.250	10.000	2.500	7.500	1
WAX41500EW-3.2	1.500	1.500	4.781	2.500	2.281	2
WAX41500ELC-3.2	1.500	1.500	10.000	2.500	7.500	2
WAX41000EW-4.0	1.000	1.000	4.781	2.500	2.281	1
WAX41000ELC-4.0	1.000	1.000	10.000	2.500	7.500	1
WAX41250EW-4.0	1.250	1.250	4.781	2.500	2.281	1
WAX41250ELC-4.0	1.250	1.250	10.000	2.500	7.500	1
WAX41500EW-4.0	1.500	1.500	4.781	2.500	2.281	2
WAX41500ELC-4.0	1.500	1.500	10.000	2.500	7.500	2

WAX 4000 Shell Mill Cutter Bodies - INCH									
Catalog Number	φDc	Φd	φd2	φd1	L1	a	b	l	No. of teeth
WAX42000-3.2	2.000	0.750	0.406	0.630	2.000	0.312	0.220	0.787	2
WAX42500-3.2	2.500	1.000	0.531	0.630	2.000	0.375	0.220	0.787	3
WAX43000-3.2	3.000	1.000	0.531	1.260	2.000	0.375	0.248	0.866	4
WAX44000-3.2	4.000	1.250	0.656	1.220	2.500	0.500	0.394	1.181	5
WAX45000-3.2	5.000	1.500	0.656	1.220	2.500	0.625	0.394	1.181	6
WAX42000-4.0	2.000	0.750	0.406	0.630	2.000	0.312	0.220	0.787	2
WAX42500-4.0	2.500	1.000	0.531	0.630	2.000	0.375	0.220	0.787	3
WAX43000-4.0	3.000	1.000	0.531	1.260	2.000	0.375	0.248	0.866	4
WAX44000-4.0	4.000	1.250	0.656	1.220	2.500	0.500	0.394	1.181	5
WAX45000-4.0	5.000	1.500	0.656	1.220	2.500	0.625	0.394	1.181	6

All WAX inch size cutters and applicable inserts are USA stocked items (please see page 344 for inserts).



Indexable Milling
Shoulder Milling
Face Milling
High Feed Milling
Multi-purpose
Modular Tooling
UFO & SumiMill
Discontinued

WAX 3000/METRIC

Applicable Insert: AECT

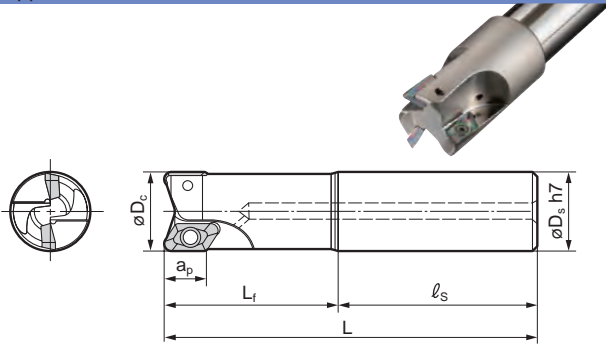

See insert table for "a_p".

Shoulder Milling Cutters

High Speed & Efficiency Non-ferrous WaveMill

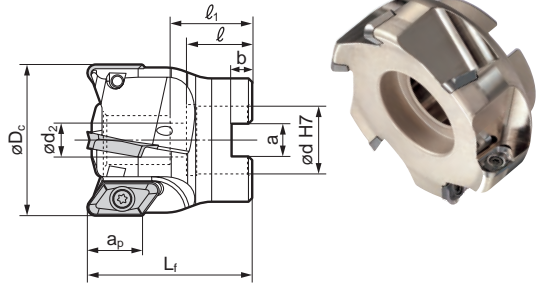

See insert table for "a_p".

Indexable Milling

Shoulder Milling

Face Milling

High Feed Milling

Multi-purpose

Modular Tooling

UFO & SumiMill

Discontinued

WAX 3000E/3000EL (For inserts with nose radius 3.2mm and below)								
Catalog Number	Stock	Dimensions (mm)					No. of Teeth	Weight (kg)
		ϕD_c	ϕD_s	L	L_f	ℓ_s		
WAX 3020E-3.2	★	20	20	130	60	70	1	0.25
WAX 3025E-3.2	★	25	25	140	60	80	2	0.42
WAX 3025EL-3.2	★	25	25	200	60	140	2	0.63
WAX 3032E-3.2	★	32	32	150	70	80	2	0.75
WAX 3032EL-3.2	★	32	32	220	70	150	2	1.2
WAX 3040E-3.2	★	40	32	160	70	90	3	1.0
WAX 3040EL-3.2	★	40	32	220	70	150	3	1.4

★ = Worldwide Warehouse Item

WAX 3000E/3000EL (For inserts with nose radius 4.0mm and above)								
Catalog Number	Stock	Dimensions (mm)					No. of Teeth	Weight (kg)
		ϕD_c	ϕD_s	L	L_f	ℓ_s		
WAX 3020E-4.0	★	20	20	130	60	70	1	0.25
WAX 3025E-4.0	★	25	25	140	60	80	2	0.42
WAX 3025EL-4.0	★	25	25	200	60	140	2	0.63
WAX 3032E-4.0	★	32	32	150	70	80	2	0.75
WAX 3032EL-4.0	★	32	32	220	70	150	2	1.2
WAX 3040E-4.0	★	40	32	160	70	90	3	1.0
WAX 3040EL-4.0	★	40	32	220	70	150	3	1.4

★ = Worldwide Warehouse Item

Inserts (for all WAX 3000 Endmills)

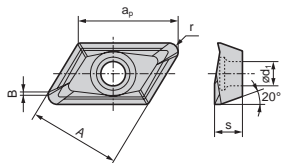

● = USA Stocked Item

Catalog Number	Carbide		Dimensions - In. (mm)					
	HI	DLC	a_p	A	B	r_e	s	ϕd_1
		DL1000						
AECT 160404PEFRA	●	●	0.708 (18)	0.6456 (16.4)	0.055 (1.4)	0.016 (0.4)	0.1968 (5)	0.1732 (4.4)
AECT 160408PEFRA	●	●	0.708 (18)	0.6456 (16.4)	0.039 (1.0)	0.031 (0.8)	0.1968 (5)	0.1732 (4.4)
AECT 160412PEFRA	●	●	0.708 (18)	0.6456 (16.4)	0.023 (0.6)	0.047 (1.2)	0.1968 (5)	0.1732 (4.4)
AECT 160416PEFRA	●	●	0.689 (17.5)	0.6456 (16.4)	0.020 (0.5)	0.063 (1.6)	0.1968 (5)	0.1732 (4.4)
AECT 160420PEFRA	●	●	0.689 (17.5)	0.6456 (16.4)	0.020 (0.5)	0.079 (2.0)	0.1968 (5)	0.1732 (4.4)
AECT 160430PEFRA	●	●	0.669 (17)	0.6456 (16.4)	0.028 (0.7)	0.118 (3.0)	0.1968 (5)	0.1732 (4.4)
AECT 160432PEFRA	●	●	0.669 (17)	0.6456 (16.4)	0.020 (0.5)	0.126 (3.2)	0.1968 (5)	0.1732 (4.4)
AECT 160440PEFRA	●	●	16.5	0.6456 (16.4)	0.020 (0.5)	0.157 (4.0)	0.1968 (5)	0.1732 (4.4)
AECT 160450PEFRA	●	●	0.630 (16)	0.6456 (16.4)	0.016 (0.4)	0.197 (5.0)	0.1968 (5)	0.1732 (4.4)

$r_e=4.0$ or greater are for use with bodies that have a -4.0 cat. no. suffix.



WAX 3000 (For inserts with nose radius 3.2mm and below)												
Catalog Number	Stock	Dimensions (mm)									No. of Teeth	Weight (kg)
		ϕD_c	ϕd	L_f	ϕd_2	a	b	ℓ	ℓ_1			
WAX 3050-3.2	★	50	22	50	11	10.4	6.3	21	26	4	0.34	
WAX 3063-3.2	★	63	22	50	11	10.4	6.3	21	26	5	0.6	
WAX 3080-3.2	★	80	25.4	50	14	9.5	6	25	31	5	1.0	
WAX 3100-3.2	★	100	31.75	63	17	12.7	8	32	39	6	2.2	
WAX 3125-3.2	★	125	38.1	63	21	15.9	10	35	40	7	3.5	

★ = Worldwide Warehouse Item

WAX 3000 (For inserts with nose radius 4.0mm and above)												
Catalog Number	Stock	Dimensions (mm)									No. of Teeth	Weight (kg)
		ϕD_c	ϕd	L_f	ϕd_2	a	b	ℓ	ℓ_1			
WAX 3050-4.0	★	50	22	50	11	10.4	6.3	21	26	4	0.34	
WAX 3063-4.0	★	63	22	50	11	10.4	6.3	21	26	4	0.6	
WAX 3080-4.0	★	80	25.4	50	14	9.5	6	25	31	5	1.0	
WAX 3100-4.0	★	100	31.75	63	17	12.7	8	32	39	6	2.2	
WAX 3125-4.0	★	125	38.1	63	21	15.9	10	35	40	7	3.5	

★ = Worldwide Warehouse Item

Hardware (for all WAX 3000 Endmills)

Screw	Spanner	Anti-seize Paste	Recommended Tightening Torque (N·m)	Applicable Endmill
			3.0	
BFTX0408	TRD15	SUMI-P		

See page 342
for recommended
running parameters

NOTE: 3.2 bodies / .125 Radius or less
4.0 bodies / over .125 Radius
on inserts





WAX 4000/METRIC

Applicable Insert: AECT

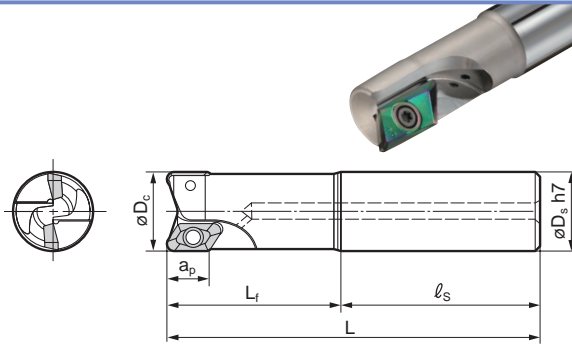

See insert table for "a_p".

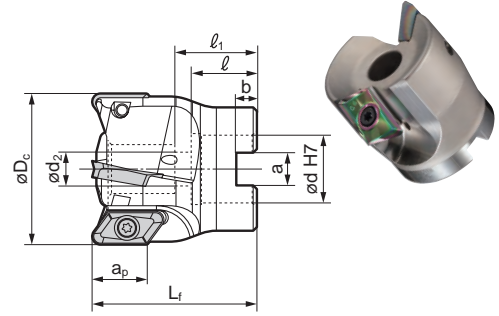

See insert table for "a_p".

WAX 4000E/4000EL		(For inserts with nose radius 3.2mm and below)						
Cat. No.	Stock	Dimensions (mm)					No. of Teeth	Weight (kg)
		ϕD_c	ϕD_s	L	L_f	ℓ_s		
WAX 4025E-3.2	★	25	25	140	60	80	1	0.41
WAX 4025EL-3.2	★	25	25	200	60	140	1	0.63
WAX 4032E-3.2	★	32	32	150	70	80	1	0.72
WAX 4032EL-3.2	★	32	32	220	70	150	1	1.2
WAX 4040E-3.2	★	40	32	160	70	90	2	0.88
WAX 4040EL-3.2	★	40	32	220	70	150	2	1.2

★ = Worldwide Warehouse Item

WAX 4000		(For inserts with nose radius 3.2mm and below)									
Cat. No.	Stock	Dimensions (mm)								No. of Teeth	Weight (kg)
		ϕD_c	ϕd	L_f	ϕd_2	a	b	ℓ	ℓ_1		
WAX 4050-3.2	★	50	16	50	9	8.4	5.6	18	23	2	0.37
WAX 4063-3.2	★	63	22	50	11	10.4	6.3	21	26	3	0.54
WAX 4080-3.2	★	80	25.4	50	14	9.5	6	25	31	4	0.81
WAX 4100-3.2	★	100	31.75	63	17	12.7	8	32	39	5	1.7
WAX 4125-3.2	★	125	38.1	63	21	15.9	10	35	40	6	2.6

★ = Worldwide Warehouse Item

WAX 4000E/4000EL		(For inserts with nose radius 4.0mm and above)						
Cat. No.	Stock	Dimensions (mm)					No. of Teeth	Weight (kg)
		ϕD_c	ϕD_s	L	L_f	ℓ_s		
WAX 4025E-4.0	★	25	25	140	60	80	1	0.41
WAX 4025EL-4.0	★	25	25	200	60	140	1	0.63
WAX 4032E-4.0	★	32	32	150	70	80	1	0.72
WAX 4032EL-4.0	★	32	32	220	70	150	1	1.2
WAX 4040E-4.0	★	40	32	160	70	90	2	0.88
WAX 4040EL-4.0	★	40	32	220	70	150	2	1.2

★ = Worldwide Warehouse Item

WAX 4000		(For inserts with nose radius 4.0mm and above)									
Cat. No.	Stock	Dimensions (mm)								No. of Teeth	Weight (kg)
		ϕD_c	ϕd	L_f	ϕd_2	a	b	ℓ	ℓ_1		
WAX 4050-4.0	★	50	16	50	9	8.4	5.6	18	23	2	0.37
WAX 4063-4.0	★	63	22	50	11	10.4	6.3	21	26	3	0.54
WAX 4080-4.0	★	80	25.4	50	14	9.5	6	25	31	4	0.81
WAX 4100-4.0	★	100	31.75	63	17	12.7	8	32	39	5	1.7
WAX 4125-4.0	★	125	38.1	63	21	15.9	10	35	40	6	2.6

★ = Worldwide Warehouse Item

Inserts (for all WAX 4000 Endmills)									
Catalog Number	Material		Dimensions - In. (mm)						
	Carbide	DLC	a_p	A	B	r_ϵ	s	ϕd_1	
	HI	DL 1000	(24)	(21.8)	(1.5)	(0.4)	(6.35)	(6.0)	
AECT 220604PEFRA	●	●	0.945	0.8563	0.059	0.016	0.250	0.236	
AECT 220608PEFRA	●	●	0.945	0.8563	0.047	0.031	0.250	0.236	
AECT 220612PEFRA	●	●	0.945	0.8563	0.031	0.047	0.250	0.236	
AECT 220616PEFRA	●	●	0.945	0.8563	0.016	0.063	0.250	0.236	
AECT 220620PEFRA	●	●	0.945	0.8563	0.020	0.079	0.250	0.236	
AECT 220630PEFRA	●	●	0.905	0.8563	0.023	0.118	0.250	0.236	
AECT 220632PEFRA	●	●	0.905	0.8563	0.016	0.126	0.250	0.236	
AECT 220640PEFRA	●	●	0.866	0.8563	0.047	0.157 (4.0)	0.250	0.236	
AECT 220650PEFRA	●	●	0.866	0.8563	0.016	0.197 (5.0)	0.250	0.236	

$r_\epsilon = 4.0$ or greater are for use with bodies that have a -4.0 cat. no. suffix.

Hardware (for all WAX 4000 Endmills)				
Screw	Spanner	Anti-seize Paste	Recommended Tightening Torque (N-m)	Applicable Endmill
			5.0	
BFTX0509N	TRD20	SUMI-P		
BFTX0511N	TRD20	SUMI-P		$\phi 40$ to $\phi 125$

See page 342
for recommended
running parameters



TSX SERIES

Applicable Insert: LNE X

NEW

8 mm	0°	12 mm	0°	Rake Angle	Radial	-34°-20°	P	M	K	N	S	H
				LNE X08	Axial	-6°	Steel	Cast Iron	Cast Iron	Aluminum	Cast Alloy	Inertial Steel
				Rake Angle	Radial	-31°-15°						
				LNE X13	Axial	-6°						



Features & Benefits

- TSX provides superior metal removal rates
- Employs a cost effective 4-corner tough, tangentially mounted insert
- Tangentially mounted insert achieves excellent edge sharpness and cutting ability with optimized chip breaker
- TSX is available in two series offering a max DOC of 8mm (.315") and 12mm (.473") with a variety of body diameter choices
- TSX provides the strength required for increased depths of cut ranging from a small job to a heavy duty roughing application

Inserts

Inserts	P	K	M	S	R			
Cat. No.	ACP100	ACP200	ACP300	ACK200	ACK300	ACM200	ACM300	
LNE X080404PNER-L	○	○	○	○	○	○	○	.016
LNE X080404PNER-G	○	○	○	○	○	○	○	.016
LNE X080408PNER-L	○	○	○	○	○	○	○	.031
LNE X080408PNER-G	○	○	○	○	○	○	○	.031
LNE X080412PNER-G	○	○	○	○	○	○	○	.047
LNE X080416PNER-G	○	○	○	○	○	○	○	.063
LNE X130604PNER-L	○	○	○	○	○	○	○	.016
LNE X130604PNER-G	○	○	○	○	○	○	○	.016
LNE X130608PNER-L	○	○	○	○	○	○	○	.031
LNE X130608PNER-G	○	○	○	○	○	○	○	.031
LNE X130608PNER-H	○	○	○	○	○	○	○	.031
LNE X130616PNER-G	○	○	○	○	○	○	○	.063
LNE X130616PNER-H	○	○	○	○	○	○	○	.063
LNE X130624PNER-G	○	○	○	○	○	○	○	.094
LNE X130624PNER-H	○	○	○	○	○	○	○	.094
LNE X130632PNER-G	○	○	○	○	○	○	○	.126
LNE X130632PNER-H	○	○	○	○	○	○	○	.126

LNE X08
Max. DOC 8mm (.315")

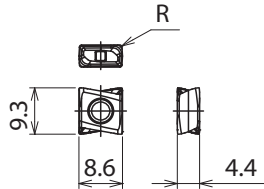

LNE X13
Max. DOC 12 mm (.473")

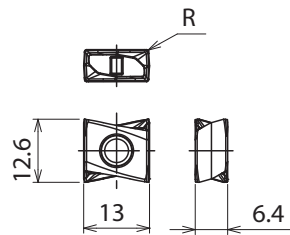

○ Available 1st Quarter 2017

Toughness Comparison



[Cutting Condition]
Material: 1049 Steel, Dry
Vc 490 SFM
fz .024 ipt
ap .118"
ae 1.58"

Fz .024 ipt	4th pass	8th pass	12th pass
Comp A (Tangential)	Brakeage		
Comp B (Tangential)	Brakeage		
TSX (LNE X)	No Brakeage		

Cutting Force Comparison

[Cutting Condition]
Material: 1049 Steel, Dry
Vc 490 SFM
fz .006 ipt
ap .236" & .472"
ae .118"

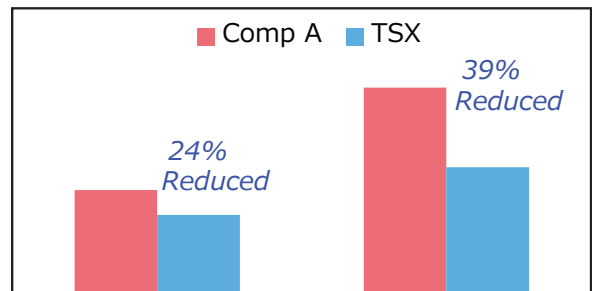

DOC=6mm (.236") DOC=12mm (.472")

Recommended Running Conditions

ISO	Work Material	Hardness	Cutting Speed v _c (sfm) Min-Max	Feed Rate f _z (ipt) Min-Max	Recommended Grade
P	Carbon Steel	180-280 HB	500-1000	.004-.014	ACP200 ACP300 ACP100
		> 280 HB	250-750	.004-.014	
	Alloy Steel	180-280HB	330-815	.004-.012	
M	Stainless Steel	220-280HB	300-600	.004-.010	ACM300 ACM200
		> 280HB	250-550	.004-.010	
S	Exotic Material	-	100-300	.004-.008	ACM300 ACM200
K	Cast Iron/Ductile Cast Iron	250HB	330-815	.004-.014	ACK300 ACK200

NOTE: The cutting conditions above are a guide. Actual conditions will need to be adjusted according to machine rigidity, work clamp rigidity, cutting depth and other factors.

Hardware

Insert Size	Catalog Number	Insert Screw	Wrench	Recommended Tightening Torque
TSX3000 (LNE X08)	TSX□30625□~TSX□30750□	BFTX0306IP	TRDR08IP	2.0Nm
	TSX□31000□~TSX□32500□	BFTX0308IP		
TSX4000 (LNE X13)	TSX□41000□~TSX□44000□	BFTX03510IP	TRDR15IP	3.0Nm



8 mm	0°	12 mm	0°	Rake Angle	Radial	-34°-20°
LNEX 08		LNEX 13		LNEX08	Axial	-6°
				Rake Angle	Radial	-31°-15°
				LNEX13	Axial	-6°



TSX Series

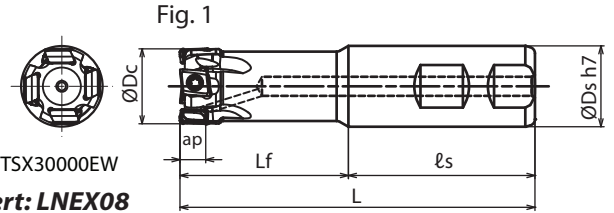
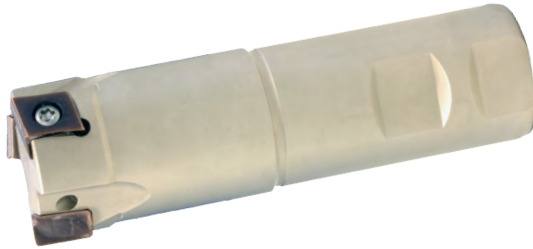

TSX30000EW
Insert: LNEX08

○ Available 1st Quarter 2017

TSX Endmill - INCH		Insert: LNEX08 Type							
Cat. No.	Stock	Dimensions (in.)					No. of Teeth	Weight (lbs)	Fig.
		ØDc	ØDs	Lf	ls	L			
TSX30625EW	○	0.625	0.625	1.312	1.906	3.218	2	0.22	1
TSX30750EW	○	0.750	0.750	1.534	2.030	3.563	2	0.35	1
TSX31000EW	○	1.000	1.000	2.060	2.281	4.341	3	0.88	1
TSX31250EW	○	1.250	1.250	2.060	2.281	4.341	3	1.32	1
TSX31500EW	○	1.500	1.250	2.060	2.281	4.341	4	1.54	1
TSXF30750EW	○	0.750	0.750	1.534	2.030	3.563	3	0.44	1
TSXF31000EW	○	1.000	1.000	2.060	2.281	4.341	4	0.88	1
TSXF31250EW	○	1.250	1.250	2.060	2.281	4.341	5	1.32	1
TSXF31500EW	○	1.500	1.250	2.060	2.281	4.341	6	1.54	1

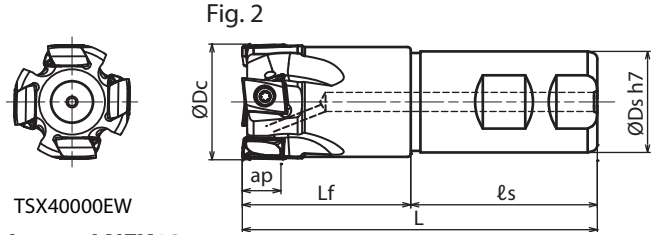

TSX40000EW
Insert: LNEX13

TSX Endmill - INCH		Insert: LNEX13 Type							
Cat. No.	Stock	Dimensions (in.)					No. of Teeth	Weight (lbs)	Fig.
		ØDc	ØDs	Lf	ls	L			
TSX41000EW	○	1.000	1.000	2.060	2.281	4.341	2	0.66	2
TSX41250EW	○	1.250	1.250	2.060	2.281	4.341	2	1.32	2
TSX41500EW	○	1.500	1.250	2.060	2.281	4.341	3	1.54	2
TSXF41250EW	○	1.250	1.250	2.060	2.281	4.341	3	1.32	2
TSXF41500EW	○	1.500	1.250	2.060	2.281	4.341	4	1.54	2



○ Available 1st Quarter 2017

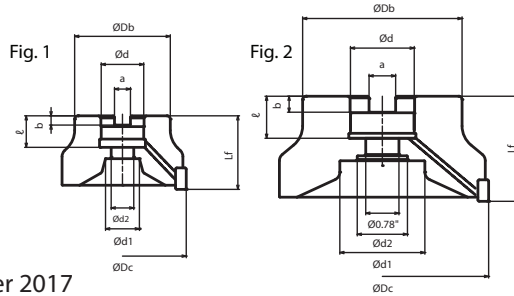

TSX Shell Mill - INCH		Insert: LNEX08 Type											
Cat. No.	Stock	Dimensions (in.)								No. of Teeth	Weight (lbs)	Fig.	
		ØDc	ØDb	Lf	Ød	a	b	ℓ	Ød1				Ød2
TSX31500R	○	1.500	1.339	1.750	0.750	0.312	0.190	0.750	0.609	0.406	4	0.44	1
TSX32000R	○	2.000	1.500	1.750	0.750	0.312	0.190	0.750	0.609	0.406	5	0.88	1
TSX32500R	○	2.500	1.750	1.750	1.000	0.375	0.220	0.750	0.797	0.531	6	1.10	1
TSXF31500R	○	1.500	1.339	1.750	0.750	0.312	0.190	0.750	0.609	0.406	6	0.44	1
TSXF32000R	○	2.000	1.500	1.750	0.750	0.312	0.190	0.750	0.609	0.406	8	0.88	1
TSXF32500R	○	2.500	1.750	1.750	1.000	0.375	0.220	0.750	0.797	0.531	10	1.10	1

TSX Shell Mill - INCH		Insert: LNEX13 Type											
Cat. No.	Stock	Dimensions (in.)								No. of Teeth	Weight (lbs)	Fig.	
		ØDc	ØDb	Lf	Ød	a	b	ℓ	Ød1				Ød2
TSX41500R	○	1.500	1.339	1.750	0.750	0.312	0.190	0.750	0.609	0.406	4	0.44	1
TSX42000R	○	2.000	1.500	1.750	0.750	0.312	0.190	0.750	0.609	0.406	5	0.66	1
TSX42500R	○	2.500	1.750	1.750	1.000	0.375	0.220	0.750	0.797	0.531	6	1.10	1
TSX43000R	○	3.000	2.250	1.750	1.000	0.375	0.220	0.750	0.797	0.531	7	1.76	1
TSX44000R	○	4.000	2.870	2.000	1.500	0.625	0.380	1.000	2.000	0.781	9	4.85	2
TSX45000R	○	5.000	3.750	2.500	1.500	0.625	0.380	1.000	2.000	0.781	12	7.50	2
TSX46000R	○	6.000	4.380	2.500	1.500	0.625	0.380	1.000	2.000	0.781	14	11.0	2
TSXF41500R	○	1.500	1.339	1.750	0.750	0.312	0.190	0.750	0.609	0.406	5	0.44	1
TSXF42000R	○	2.000	1.500	1.750	0.750	0.312	0.190	0.750	0.609	0.406	6	0.66	1
TSXF42500R	○	2.500	1.750	1.750	1.000	0.375	0.220	0.750	0.797	0.531	8	1.10	1
TSXF43000R	○	3.000	2.250	1.750	1.000	0.375	0.220	0.750	0.797	0.531	10	1.76	1
TSXF44000R	○	4.000	2.870	2.000	1.500	0.625	0.380	1.000	2.000	0.781	13	4.85	2



Rake Angle	Radial	-15°	16mm	0°
	Axial	-6°		



Features & Benefits

- Highly reliable shoulder mill tangentially mounted for never-before-possible cutting edge strength and sharp cutting edges.
- A two-step insert array structure creates a **PWSR Type** to meet deep cutting needs
- Tangentially mounted inserts for outstanding cutting edge strength combined with optimized breaker for excellent edge sharpness and cutting ability.
- Serrated insert design created with high-precision molding technology provides stable milling, even in applications with large tool overhang
- New ACP and ACK milling grades are used to meet the needs of various types of work material

Performance

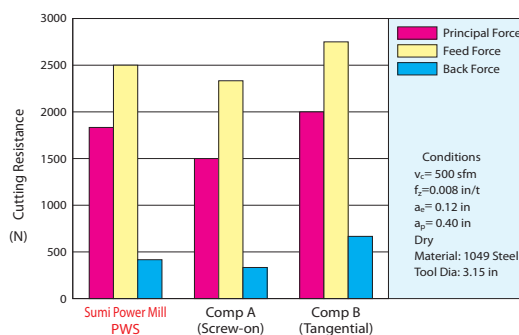
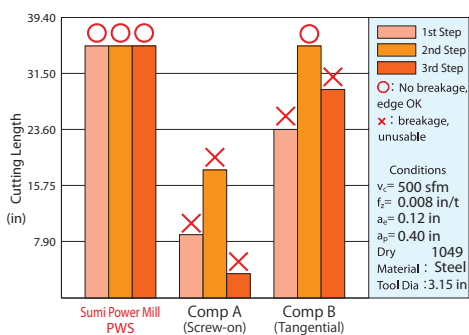

Performance Comparison

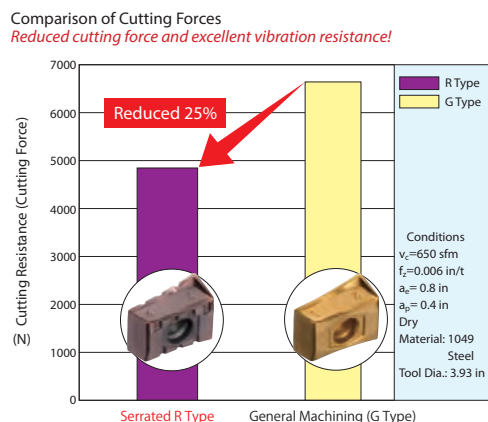
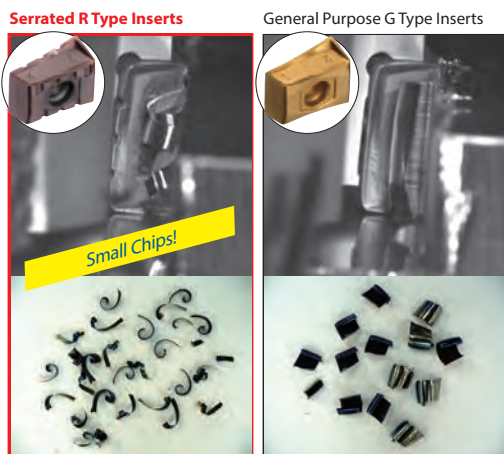

Caution when using Serrated R Type Inserts

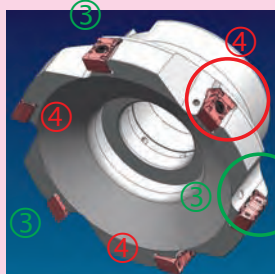

1) Installation Precautions

When using R type serrated indexable inserts, attach them so the serrated grooves alternate as shown in the image to the left.

2) Cutting Condition Precautions

When set up as shown in the image to the left, the feed rate per tooth is doubled compared to that when attaching the same-shaped inserts on all teeth. This means that feed adjustments should be made so the upper feed limit is as shown below.

$$f_z = 0.010 \text{ IPT}$$

Example: Use at $f_z = 0.008$ IPT

Feed when all teeth are normal

Feed when serrated **0.016 IPT**

Any incorrect use of insert may damage tools.



Rake Angle	Radial	-15°	16mm	0°	<table border="1"> <tr> <td>P</td><td>M</td><td>K</td><td>N</td><td>S</td><td>H</td> </tr> <tr> <td>Steel</td><td>Stainless Steel</td><td>Cast Iron</td><td>Non-ferrous</td><td>Super Alloy</td><td>Hardened Material</td> </tr> </table>	P	M	K	N	S	H	Steel	Stainless Steel	Cast Iron	Non-ferrous	Super Alloy	Hardened Material
	P	M				K	N	S	H								
Steel	Stainless Steel	Cast Iron	Non-ferrous	Super Alloy	Hardened Material												
Axial	-6°																

PWS Series

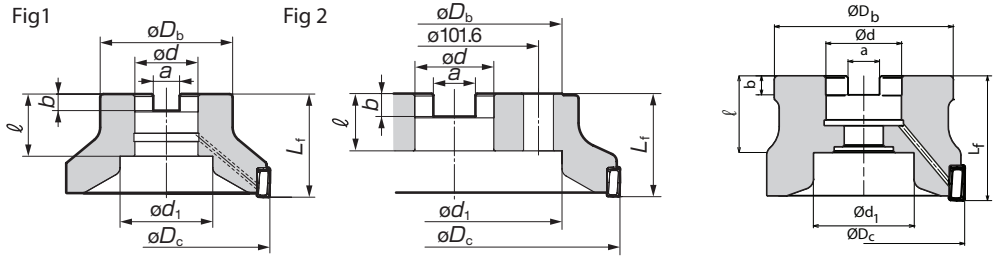

PWS Cutter Bodies - Standard Pitch - Inch

Catalog Number	Stock	Dimensions								# of Teeth	Weight (lbs)	Fig.
		ϕD_c	ϕD_b	L_f	ϕd	ϕD_1	a	b	ℓ			
PWS43000R	●	3.000	2.250	1.750	1.000	0.797	0.375	0.220	1.020	5	2.10	1
PWS44000R-1.25	●	4.000	2.870	2.000	1.250	1.000	0.500	0.280	1.020	6	5.29	1
PWS44000R-1.50	●	4.000	3.540	2.500	1.500	2.000	0.625	0.380	2.400	6	5.40	3
PWS45000R	●	5.000	3.750	2.500	1.500	2.000	0.625	0.380	1.535	7	5.29	1
PWS46000R	●	6.000	4.380	2.500	1.500	2.000	0.625	0.380	1.535	8	8.81	1
PWS48000R	●	8.000	5.118	2.500	2.500	-	1.000	0.560	1.594	10	14.33	2
PWS410000R	●	10.000	7.087	2.756	2.500	-	1.000	0.560	1.594	12	27.11	2

PWS Cutter Bodies - Fine Pitch - Inch

Catalog Number	Stock	Dimensions								# of Teeth	Weight (lbs)	Fig.
		ϕD_c	ϕD_b	L_f	ϕd	ϕD_1	a	b	ℓ			
PWSF43000R	●	3.000	2.250	1.750	1.000	0.797	0.375	0.220	1.020	7	1.95	1
PWSF44000R-1.25	●	4.000	2.870	2.000	1.250	1.000	0.500	0.280	1.020	9	5.07	1
PWSF44000R-1.50	●	4.000	3.540	2.500	1.500	2.000	0.625	0.380	2.400	9	5.10	3
PWSF45000R	●	5.000	3.750	2.500	1.500	2.000	0.625	0.380	1.535	10	5.07	1
PWSF46000R	●	6.000	4.380	2.500	1.500	2.000	0.625	0.380	1.535	13	8.59	1
PWSF48000R	●	8.000	5.118	2.500	2.500	-	1.000	0.560	1.594	16	14.10	2
PWSF410000R	●	10.000	7.087	2.756	2.500	-	1.000	0.560	1.594	20	26.90	2

*Cutters with sizes of $\phi 8.000$ inches or above come with seats (no coolant holes). Inserts are not included.

Inserts

P Steel M Stainless Steel K Cast Iron N Non-ferrous S Super Alloy H Hardened Material

Application	Grade	Coated Carbide					Application	Fig.
	High speed/Light	P			K			
	General Purpose	M	M	K				
	Roughing	M	M	K				
Catalog Number	ACP100	ACP200	ACP300	ACK200	ACK300			
LNMX170808PNSR-L	●	●	●	●	●	Light Cut	10	
LNMX170808PNSR-G	●	●	●	●	●	General Purpose	10	
LNMX170808PNSR-R	●	●	●	●	●	Heavy Cut	11	

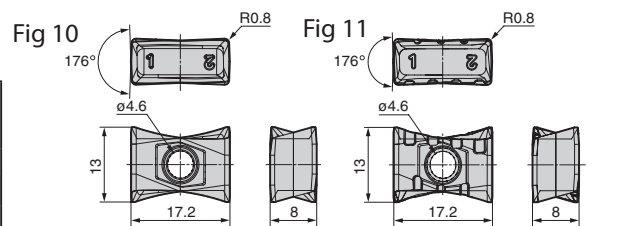

Recommended Cutting Conditions

ISO	Work Material	Hardness	Cutting Speed v_c (sfm) Min-Max	Feed Rate f_2 (ipt) Min-Max	Recommended Grade
P	Carbon Steel	180-280HB	500-1,500	0.004-0.014	ACP200
	Alloy Steel	180-280HB	330-815	0.004-0.010	ACP200
M	Stainless Steel	-	330-650	0.006-0.010	ACP300
K	Cast Iron/Ductile	250HB	330-815	0.004-0.014	ACK200
	Cast Iron				

NOTE: The cutting conditions above are a guide. Actual Conditions will need to be adjusted according to machine rigidity, work clamp rigidity, cutting depth and other factors.



PWS Series

Rake Angle	Radial	-15°	16mm	0°
	Axial	-6°		

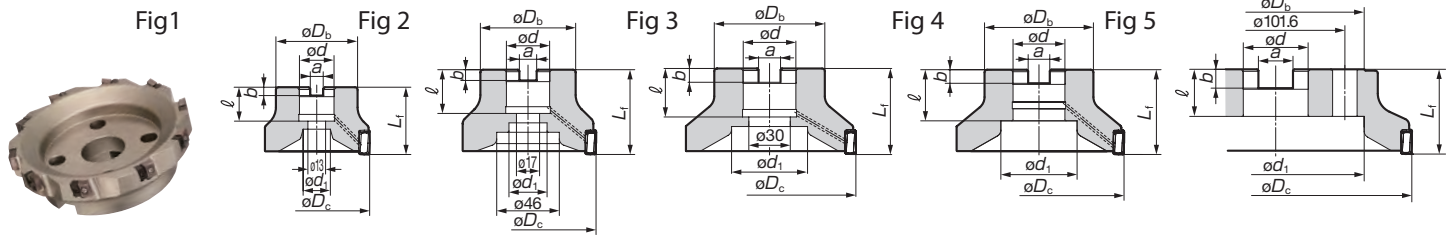

PWS Cutter Bodies - Standard Pitch - Metric

Catalog Number	Stock	Dimensions								# of Teeth	Weight (kg)	Fig.
		ϕD_c	ϕD_b	L_f	ϕd	ϕd_1	a	b	ℓ			
PWS 4080R	●	80	60	50	25.4	20	9.5	6	25	4	1.0	1
PWS 4100R	●	100	70	63	31.75	28	12.7	8	32.5	6	1.8	2
PWS 4125R	●	125	80	63	38.1	55	15.9	10	35.5	6	2.4	3
PWS 4160R	●	160	100	63	50.8	72	19.0	11	38	8	4.0	4
PWS 4200R	●	200	130	63	50.8	130	25.4	14	35	10	6.5	5
PWS 4250R	●	250	130	63	50.8	160	25.4	14	35	12	12.3	5

PWS Cutter Bodies - Fine Pitch - Metric

Catalog Number	Stock	Dimensions								# of Teeth	Weight (kg)	Fig.
		ϕD_c	ϕD_b	L_f	ϕd	ϕd_1	a	b	ℓ			
PWSF4080R	●	80	60	50	25.4	20	9.5	6	25	6	0.9	1
PWSF4100R	●	100	70	63	31.75	28	12.7	8	32.5	8	1.7	2
PWSF4125R	●	125	80	63	38.1	55	15.9	10	35.5	8	2.3	3
PWSF4160R	●	160	100	63	50.8	72	19.0	11	38	10	3.9	4
PWSF4200R	●	200	130	63	50.8	130	25.4	14	35	12	6.4	5
PWSF4250R	●	250	130	63	50.8	160	25.4	14	35	14	12.2	5

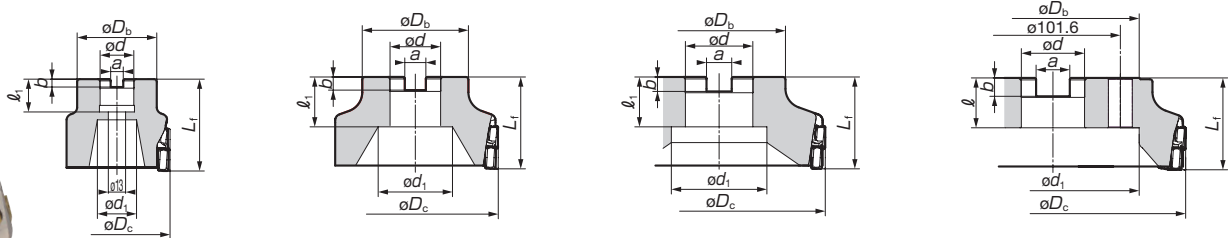
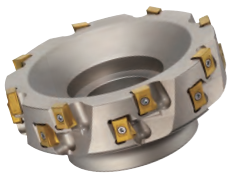

PWS Cutter Bodies - 2-step Type - Metric

Catalog Number	Stock	Dimensions								# of Teeth	Effective Teeth	Weight	Fig.
		ϕD_c	ϕD_b	L_f	ϕd	ϕd_1	a	b	ℓ				
PWSR4080R	●	80	60	70	25.4	29.5	9.5	6	25	8	4	0.9	1
PWSR4100R	●	100	70	70	31.75	46	12.7	8	32	12	6	1.7	2
PWSR4125R	●	125	80	70	38.1	56	15.9	10	38	12	6	2.3	3
PWSR4160R	●	160	100	70	50.8	72	19.0	11	38	16	8	3.9	4
PWSR4200R	●	200	130	70	50.8	160	25.4	14	38	20	10	6.4	5

*Cutters with sizes of $\phi 200$ or above come with seats (no coolant holes). Inserts are not included. Please use JIS B1176 hexagonal bolt ($\phi 80$: M12x30 to 35mm, $\phi 100$: M16x40 to 45mm) for securing $\phi 80/\phi 100$ cutter to the arbor.

Spare Parts

Insert Screw	Wrench	Anti-seize Paste	Seat*	Recommended Tightening Torque
BFTX0412IP	TRDR15IP	SUMI-P	PWSS4R	

*Included with $\phi 200$ mm or larger

Large diameter ($\phi 200$ or above) body structure
Safety seat design protects body

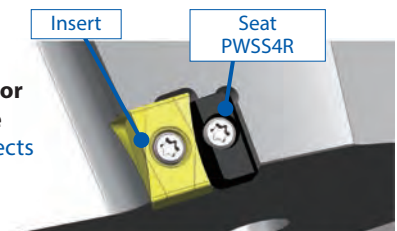

Rake Radial	Radial	-8°	10mm	0°	<table border="1"> <tr> <td>P</td> <td>M</td> <td>K</td> <td>N</td> <td>S</td> <td>H</td> </tr> <tr> <td>Steel</td> <td>Cast Iron</td> <td>Cast Iron</td> <td>Aluminum</td> <td>Exotic Alloy</td> <td>Super Alloy</td> </tr> </table>	P	M	K	N	S	H	Steel	Cast Iron	Cast Iron	Aluminum	Exotic Alloy	Super Alloy
P	M	K				N	S	H									
Steel	Cast Iron	Cast Iron	Aluminum	Exotic Alloy	Super Alloy												
Angle	Axial	8°															

WFX SERIES

Applicable Insert: SOMT

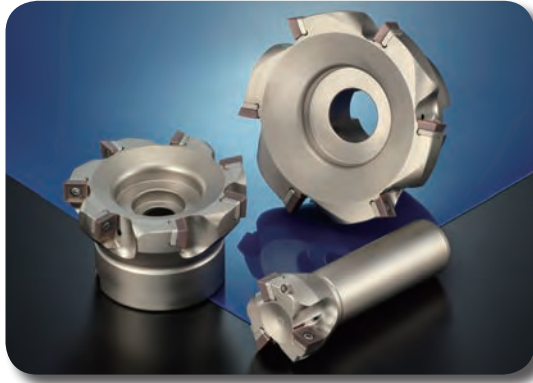

Features & Benefits

WFX WaveMill is a screw-down type cutter capable of using 4-cornered inserts. Ideal cutting edge design offers exceptional squareness.

Characteristics

The insert shape is optimized for shoulder milling; when combined with a high-precision body it leaves a superior machined surface finish.

- Maximum depth of cut (a_p) = 0.394" (10.0mm)
- With oil hole = $\varnothing 5$ " or less (125 mm)
- 3 types of edge preparations

The WFX type is the first series to offer the newly developed multi-layer PVD coating structure on these grades: **ACP200, ACP300, ACK300 and ACM 300**. With excellent resistance against wear, fracture, and adhesion, the grades achieve 1.5 times longer tool life than conventional coating.

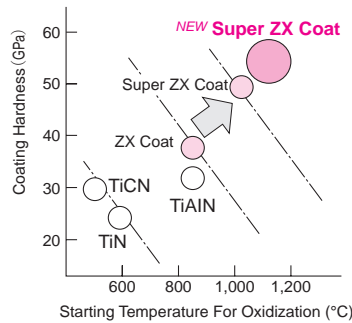

Performance

(1) Squareness

Work material: 1049 Tool: WFX12100R ($\varnothing 3.94$ " x 5 flutes)

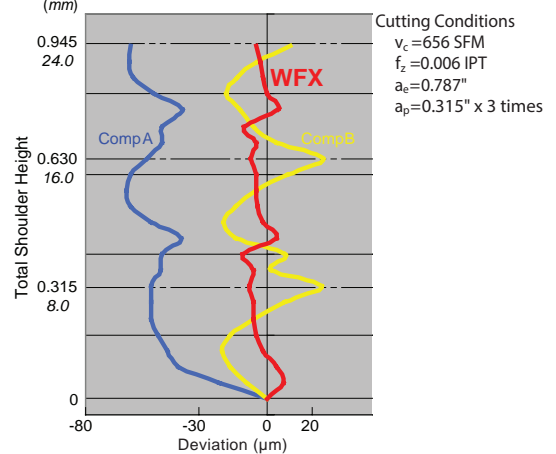

(2) Wear Resistance

Work material: 4140 Tool: WFX12100R ($\varnothing 3.94$ " x 1 flute test)
 Cutting Conditions $v_c = 656$ SFM $f_z = 0.006$ IPT $a_e = 1.181$ " $a_p = 0.1969$ "

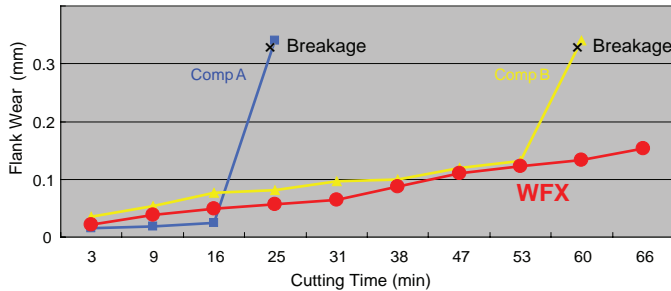

(3) Surface Finish

Work material: 4140
 Tool: WFX12100R ($\varnothing 3.94$ " x 5 flutes)
 Cutting Conditions $v_c = 656$ SFM
 $f_z = 0.004$ IPT
 $a_e = 3.543$ "
 $a_p = 0.118$ "

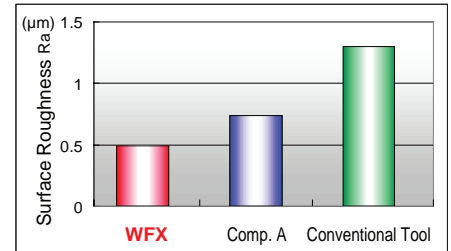

Spare Parts

Applicable Cutters	Seat	Seat Screw	Insert Screw	Torque	Wrench (insert)	Wrench (seat)
WFX12040E	-	-	BFTX03512IP	3.0N*m	TRDR15IP	-
Other WFX types	WFXS4R	BW0507F	BFTX03512IP	3.0N*m	TRDR15IP	LH035

Coolant Through Bolts	
Catalog Number	Cutter Size
BFXH 3/8 x 1	2.00"
BFXH 1/2 x 1 1/4	2.50"
BFXH 1/2 x 1 1/4	3.00"
BFXH 5/8 x 1 1/4	4.00"
BFXH 3/4 x 1 1/2	5.00"

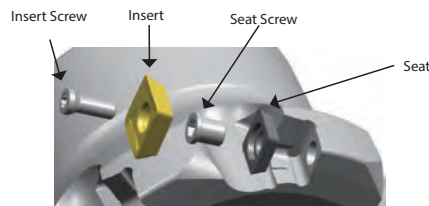

Recommended Cutting Conditions

ISO	Work Material	Cutting Speed v_c (SFM/m/min)		Feed Rate f_z (IPT/mm/t)		D.O.C. (In/mm)	Grades
		Min.	Optimum-Max	Min.	Optimum-Max		
P	General Steel	492	656-820	0.004	0.006-0.008	< 0.394	ACP200
		150	200-250	0.10	0.15-0.20	< 10.0	ACP300
	Soft Steel	591	869-1148	0.004	0.006-0.008	< 0.394	ACP200
		180	265-350	0.10	0.15-0.20	< 10.0	ACP300
M	Die Steel	328	492-656	0.004	0.006-0.008	< 0.236	ACP200
		100	150-200	0.10	0.15-0.20	< 6.0	ACP300
	Stainless Steel	175	425-675	0.004	0.006-0.008	< 0.394	ACM200
		55	130-300	0.10	0.15-0.20	< 10.0	ACM200
525		650-820	0.004	0.006-0.008	< 0.394	ACP300	
160		200-250	0.10	0.15-0.20	< 10.0	ACP300	
K	Cast Iron	328	574-820	0.004	0.006-0.008	< 0.394	ACK200
		100	175-250	0.10	0.15-0.20	< 10.0	ACK300



Indexable Milling
 Shoulder Milling
 Face Milling
 High Feed Milling
 Multi-purpose
 Modular Tooling
 UFO & SumiMill
 Discontinued

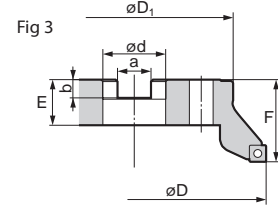
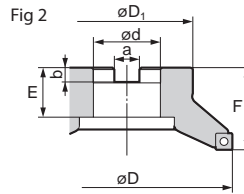
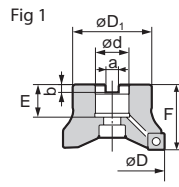

WFX Cutter Bodies - INCH

Cat. No.	Stock	Dimensions (inch)							No. of Teeth	Pitch	Fig	
		ϕD	ϕD_1	F	ϕd	a	b	E				
WFX4200R	●	2.000	1.500	1.750	0.750	0.312	0.187	0.750	3	Coarse	1	
WFX4250R	●	2.500	1.750	1.750	1.000	0.375	0.218	0.750	4		1	
WFX4300R	●	3.000	2.250	1.750	1.000	0.375	0.218	0.750	4		1	
WFX4400R	●	4.000	2.870	2.000	1.250	0.500	0.280	0.750	5		1	
WFX4400R-1.50	●	4.000	4.000	2.500	1.500	0.625	0.380	1.000	5		3	
WFX4500R	●	5.000	3.750	2.500	1.500	0.625	0.380	1.000	6		1	
WFX4600R	●	6.000	4.380	2.500	1.500	0.625	0.380	1.060	8		2	
WFX4800R	●	8.000	5.120	2.500	2.500	1.000	0.560	1.595	10		3	
WFXF4200R	●	2.000	1.500	1.750	0.750	0.312	0.187	1.020	4		Fine	1
WFXF4250R	●	2.500	1.750	1.750	1.000	0.375	0.218	1.020	5			1
WFXF4300R	●	3.000	2.250	1.750	1.000	0.375	0.218	1.020	6	1		
WFXF4400R	●	4.000	2.870	2.000	1.250	0.500	0.280	1.060	7	1		
WFXF4400R-1.50	●	4.000	4.000	2.500	1.500	0.625	0.380	1.000	7	3		
WFXF4500R	●	5.000	3.750	2.500	1.500	0.625	0.380	1.060	8	1		
WFXF4600R	●	6.000	4.380	2.500	1.500	0.625	0.380	1.060	12	2		
WFXF4800R	●	8.000	5.120	2.500	2.500	1.000	0.560	1.595	16	3		
WFXX4200R	●	2.000	1.500	1.750	0.750	0.312	0.187	1.020	5	Super Fine		1
WFXX4250R	●	2.500	1.750	1.750	1.000	0.375	0.218	1.020	6			1
WFXX4300R	●	3.000	2.250	1.750	1.000	0.375	0.218	1.020	8		1	
WFXX4400R	●	4.000	2.870	2.000	1.250	0.500	0.280	1.060	10		1	
WFXX4400R-1.50	●	4.000	4.000	2.500	1.500	0.625	0.380	1.000	10		3	
WFXX4500R	●	5.000	3.750	2.500	1.500	0.625	0.380	1.060	12		1	

-1.50 is Arbor ϕ

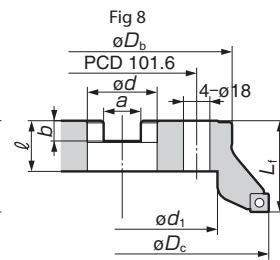
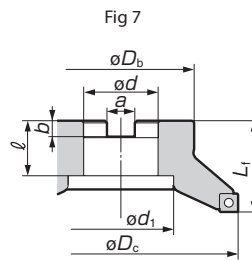
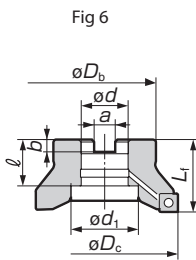
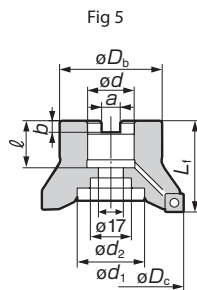
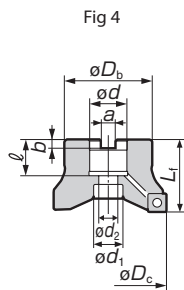

WFX Cutter Bodies - METRIC (Coarse Pitch)

Cat. No.	Stock	Dimensions (mm)									No. of Teeth	Weight (kg)	Fig
		ϕD_c	ϕD_b	L_f	ϕd	a	b	l	ϕd_1	ϕd_2			
WFX12050RS	★	50	40	40	22	10.4	6.3	20	18	11	3	0.2	4
WFX12063RS	★	63	50	40	22	10.4	6.3	20	18	11	4	0.4	4
WFX12080RS	★	80	60	50	27	12.4	7	25	20	13.5	4	0.9	4
WFX12100RS	★	100	70	50	32	14.4	8.5	32	46	-	5	1.3	6
WFX12080R	★	80	60	50	25.4	9.5	6	25	20	13	4	0.9	4
WFX12100R	★	100	70	63	31.75	12.7	8	32.5	46	28	5	1.7	5
WFX12125R	★	125	80	63	38.1	15.9	10	35.5	55	30	6	2.4	4
WFX12160R	★	160	100	63	50.8	19	11	38	72	-	8	3.7	7
WFX12200R	★	200	150	63	47.625	25.4	14	35	130	-	10	6.3	8
WFX12250R	★	250	190	63	47.625	25.4	14	35	150	-	12	11.0	8

★: Worldwide Warehouse Item



Rake Radial Angle	Radial	-8°	10mm	0°	
	Axial	8°			

WFX SERIES

Applicable Insert: SOMT

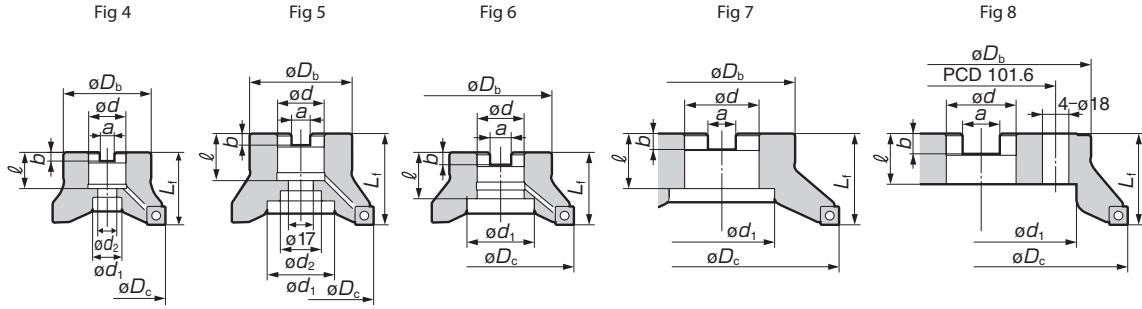

WFX Cutter Bodies - METRIC (Fine Pitch)													
Cat. No.	Stock	Dimensions (mm)									No. of Teeth	Weight (kg)	Fig
		øD _c	øD _b	L _f	ød	a	b	ℓ	ød ₁	ød ₂			
WFXF12050RS	★	50	40	40	22	10.4	6.3	20	18	11	4	0.2	1
WFXF12063RS	★	63	50	40	22	10.4	6.3	20	18	11	5	0.4	1
WFXF12080RS	★	80	60	50	27	12.4	7	25	20	13.5	6	0.9	1
WFXF12100RS	★	100	70	50	32	14.4	8.5	32	46	-	7	1.2	3
WFXF12080R	★	80	60	50	25.4	9.5	6	25	20	13	6	0.9	1
WFXF12100R	★	100	70	63	31.75	12.7	8	32.5	46	28	7	1.6	2
WFXF12125R	★	125	80	63	38.1	15.9	10	35.5	55	30	8	2.4	1
WFXF12160R	★	160	100	63	50.8	19	11	38	72	-	12	3.5	4
WFXF12200R	★	200	150	63	47.625	25.4	14	35	130	-	16	6.2	5
WFXF12250R	★	250	190	63	47.625	25.4	14	35	150	-	18	10.9	5

★: Worldwide Warehouse Item

Inserts are not included. * Cutters ø160 mm or above do not have coolant holes.

Please use JISB1176 "hexagonal bolt" (ø80: M12 x 30-35mm, ø100: M16 x 40-45mm) for securing the ø80 or ø100 cutter to the arbor.

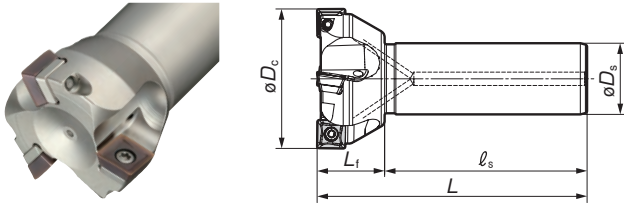

Body (Shank Type)							
Cat. No.	Stock	Dimensions (mm)					No. of Teeth
		øD _c	øD _s	L _f	ℓ _s	L	
WFX12040E	★	40	32	30	90	120	3
WFX12050E	★	50	32	30	90	120	3
WFX12063E	★	63	32	30	90	120	4
WFX12080E	★	80	32	30	90	120	4

Body (Shank, Fine Pitched Type)							
Cat. No.	Stock	Dimensions (mm)					No. of Teeth
		øD _c	øD _s	L _f	ℓ _s	L	
WFXF12050E	★	50	32	30	90	120	4
WFXF12063E	★	63	32	30	90	120	5
WFXF12080E	★	80	32	30	90	120	6

★: Worldwide Warehouse Item

ø40 mm cutters do not have a seat.

See page 351
for recommended
running parameters

Inserts	P										K	M	N	Dim. (mm)		SOMT/SOET
	Cat. No.	ACP100	ACP200	ACP300	T4500A	ACK200	ACK300	ACM200	ACM300	DL1000	H1	W	T	R		
															W	
SOMT120408PDER-L	●	●	●			●	●	●	●			12.7	4.76	0.8		
SOMT120404PDER-G	●	●	●			●	●	●	●					0.4		
SOMT120408PDER-G	●	●	●	★		●	●	●	●					0.8		
SOMT120412PDER-G	●	●	●			●	●	●	●					1.2		
SOMT120416PDER-G	●	●	●			●	●	●	●					1.6		
SOMT120408PDER-H	●	●	●			●	●	●	●					0.8		
SOET120408PDFR-S										●	●					
XOEW120408PDTR-AW				●		●						12.85	4.76			



Indexable Milling
Shoulder Milling
Face Milling
High Feed Milling
Multi-purpose
Modular Tooling
UFO & SumiMill
Discontinued



SUMITOMO

CARBIDE - CBN - DIAMOND

1-800-950-5202

www.sumicarbide.com

Face Milling

Pages 355-372



INDEXABLE MILLING CUTTERS

PAGES

WGX Series Endmills/Shell Mills	356-359
DGC Series Endmills/Shell Mills	360-363
DFC Series Endmills/Shell Mills	364-367
GOALMILL	368-369
DNX Series Face Mills	370-371
Spider Mill Cast Iron Face Mill	372

Indexable
Milling

Shoulder
Milling

Face
Milling

High
Feed
Milling

Multi-
purpose

Modular
Tooling

UFO &
SumiMill

Discon-
tinued

WGX Series

Rake Angle	Radial	-20° to -24°	6 mm / 45°	<table border="1"> <tr> <td>P</td><td>M</td><td>K</td><td>N</td><td>N</td><td>S</td><td>H</td> </tr> <tr> <td>Steel</td><td>Inconel</td><td>Cast Iron</td><td>Inconel</td><td>Aluminum</td><td>Exotic Alloy</td><td>Industrial</td> </tr> </table>	P	M	K	N	N	S	H	Steel	Inconel	Cast Iron	Inconel	Aluminum	Exotic Alloy	Industrial
P	M	K			N	N	S	H										
Steel	Inconel	Cast Iron	Inconel	Aluminum	Exotic Alloy	Industrial												
	Axial	20° to 22°																

Features & Benefits

Stable Machining

Special chipbreaker designed for WGX Type ensures low cutting resistance

High Quality

Improved run-out precision and unique wiper edge shape ensure excellent surface finish quality

Optimized chamfer shape reduces burrs and edge chipping

Long Tool Life

Features high-precision technology that reduces insert run-out variation and a new coating to provide stable and long tool life

- New Super ZX, Super FF and DLC coated grades available
- Available in Standard, Fine Pitch and Extra-Fine Pitch cutters



Insert Information

Inserts	P		K	M	S	N	Dimensions							
	ACP100	ACP200	ACP300	T4500A	ACK200	ACK300	ACM200	ACM300	DL1000	H1	IC	Thickness	Facet Width	
SEMT13T3AGSR-L	•	•	•		•	•	•	•				0.528	0.156	0.0787
SEMT13T3AGSR-G	•	•	•		•	•	•	•						
SEMT13T3AGSR-H	•	•	•		•	•	•	•						
SEMT13T3AGSR-FG	•	•	•		•	•	•	•						
SEET13T3AGSR-L	•	•	•	★	•	•	•	•						
SEET13T3AGSR-G	•	•	•	★	•	•	•	•						
SEET13T3AGFR-L									•	•				
XEEW13T3AGER-AWR	•		•		•								0.320	

Parts Diagram

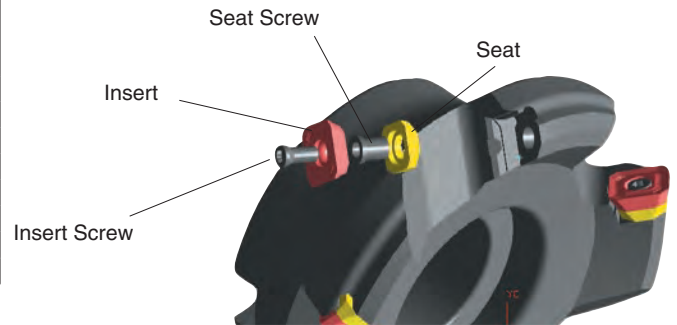

General Purpose G Type Chipbreaker

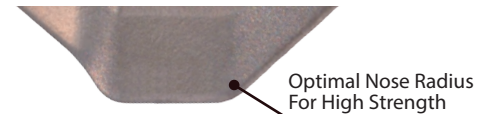

Low-Burr Design FG Type Chipbreaker

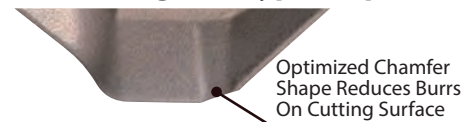

Parts

Applicable Cutters	Seat	Seat Screw	Insert Screw	Spanner (For Insert)	Recommended Tightening Torque Inch / LBs	Spanner (For Seat)
WGX cutters except for model below	WGCS13R	BW0507F	BFTX03512IP	TRDR15IP	25	LH035
WGX13032EW	—	—	BFTX03512IP	TRDR15IP	25	—

Part Exit Comparison



Cutting Resistance Comparison

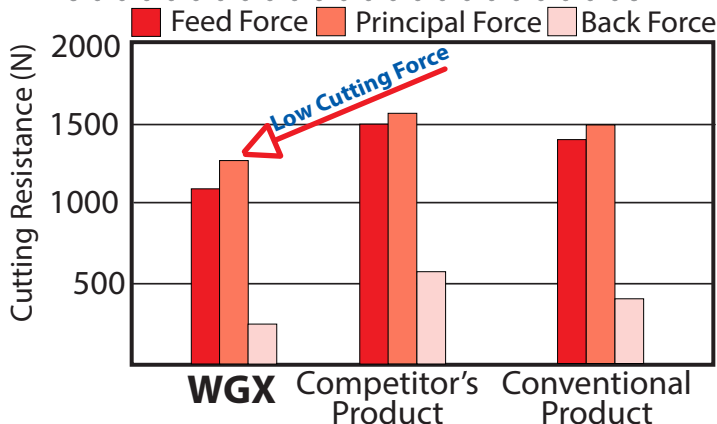

Workpiece Material: 1049 Steel Cutter Diameter: 4.000"
 Cutting Conditions: V_c : 650 SFM f_z : 0.0079 ipt a_p : .118 in

Finishing Surface Roughness Comparison

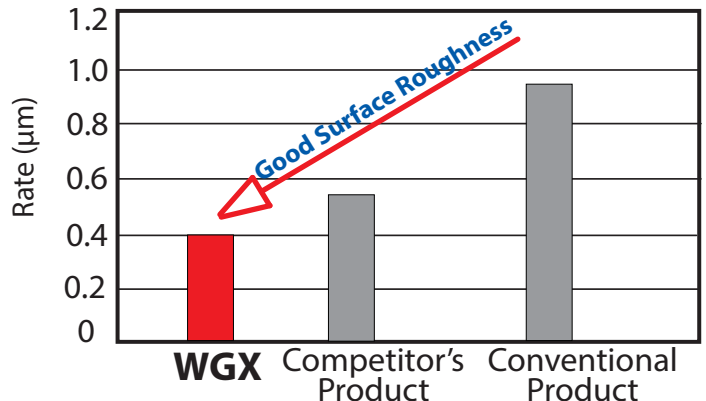

Workpiece Material: 1049 Steel Cutter Diameter: 4.000"
 Cutting Conditions: V_c : 650 SFM f_z : .00079ipt a_p : .118 in



Indexable Milling
Shoulder Milling
Face Milling
High Feed Milling
Multi-purpose
Modular Tooling
UFO & SumiMill
Discontinued

Rake Angle	Radial	-20° to -24°
	Axial	20° to 22°



WGX Series

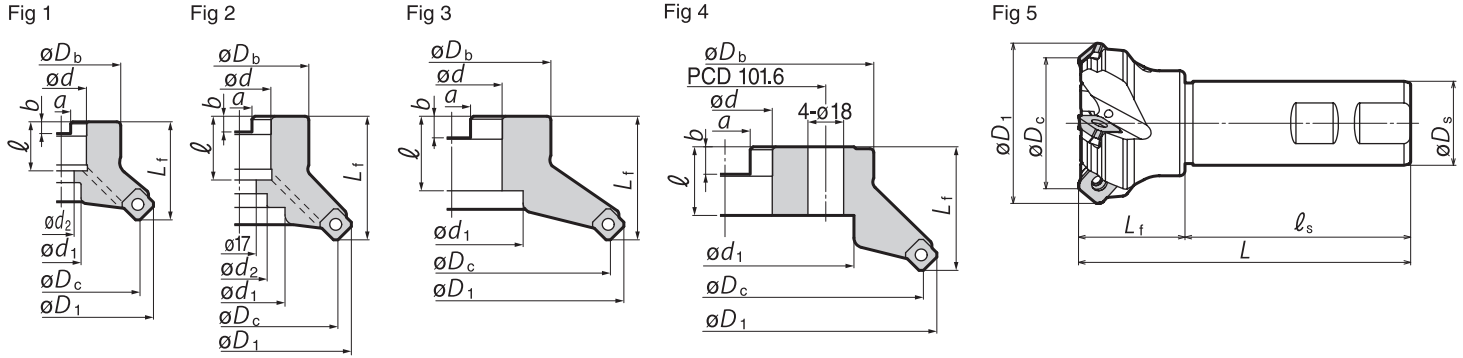

WGX Cutter Bodies- Standard Pitch-INCH

Catalog No.	Stock	φD _C	φD ₁	φD _b	L _f	φd	φd ₁	a	b	ℓ	Teeth	Weight (lbs)	Fig.
WGX42000R	●	2.000	2.461	1.500	1.750	0.750	0.609	0.312	0.190	0.750	3	0.9	1
WGX42500R	●	2.500	3.008	1.750	1.750	1.000	0.797	0.375	0.220	0.750	4	1.3	1
WGX43000R	●	3.000	3.504	2.250	1.750	1.000	0.787	0.375	0.220	0.750	4	2.2	1
WGX44000R	●	4.000	4.500	2.870	2.000	1.250	1.000	0.500	0.280	0.750	5	3.5	2
WGX44000R-1.50	●	4.000	4.500	3.750	2.500	1.500	2.000	0.625	0.380	1.000	5	4.5	3
WGX45000R	●	5.000	5.496	3.750	2.500	1.500	2.000	0.625	0.380	1.000	6	7.2	1
WGX46000R	●	6.000	6.496	4.380	2.500	1.500	2.000	0.625	0.380	1.060	7	9.5	3
WGX48000R	●	8.000	8.496	5.906	2.500	2.500	5.118	1.000	0.560	1.594	8	15.6	4
WGX410000R	●	10.000	10.492	7.480	2.756	2.500	6.299	1.000	0.531	1.575	10	23.5	4

WGX Cutter Bodies-Fine Pitch-INCH

Catalog No.	Stock	φD _C	φD ₁	φD _b	L _f	φd	φd ₁	a	b	ℓ	Teeth	Weight (lbs)	Fig.
WGX42000R	●	2.000	2.461	1.500	1.750	0.750	0.609	0.312	0.190	0.750	4	0.9	1
WGX42500R	●	2.500	3.008	1.750	1.750	1.000	0.797	0.375	0.220	0.750	5	1.9	1
WGX43000R	●	3.000	3.504	2.250	1.750	1.000	0.787	0.375	0.220	0.750	6	3.1	1
WGX44000R	●	4.000	4.500	2.870	2.000	1.250	1.000	0.500	0.280	0.750	7	4.8	2
WGX44000R-1.50	●	4.000	4.500	3.750	2.500	1.500	2.000	0.625	0.380	1.000	7	5.5	3
WGX45000R	●	5.000	5.496	3.750	2.500	1.500	2.000	0.625	0.380	1.000	8	7.2	1
WGX46000R	●	6.000	6.496	4.380	2.500	1.500	2.000	0.625	0.380	1.060	10	9.5	3
WGX48000R	●	8.000	8.496	5.906	2.500	2.500	5.118	1.000	0.560	1.594	12	15.6	4

WGX Cutter Bodies-Extra Fine Pitch-INCH

Catalog No.	Stock	φD _C	φD ₁	φD _b	L _f	φd	φd ₁	a	b	ℓ	Teeth	Weight (lbs)	Fig.
WGX42000R	●	2.000	2.461	1.500	1.750	0.750	0.609	0.312	0.190	0.750	5	0.9	1
WGX42500R	●	2.500	3.008	1.750	1.750	1.000	0.797	0.375	0.220	0.750	6	1.5	1
WGX43000R	●	3.000	3.504	2.250	1.750	1.000	0.787	0.375	0.220	0.750	8	3.1	1
WGX44000R	●	4.000	4.500	2.870	2.000	1.250	1.000	0.500	0.280	0.750	10	4.7	2
WGX44000R-1.50	●	4.000	4.500	3.750	2.500	1.500	2.000	0.625	0.380	1.000	10	6.5	3
WGX45000R	●	5.000	5.496	3.750	2.500	1.500	2.000	0.625	0.380	1.000	12	8.2	1
WGX46000R	●	6.000	6.496	4.380	2.500	1.500	2.000	0.625	0.380	1.060	16	10.5	3
WGX48000R	●	8.000	8.496	5.906	2.500	2.500	5.118	1.000	0.560	1.594	20	15.2	4

Cutter diameters 6.000" and above do not have coolant holes

WGX Cutter Bodies - Shank - INCH

Catalog No.	Stock	φD _C	φD ₁	φD _S	L _f	ℓ _s	L	Teeth	Fig.
WGX42000EW	●	2.000	2.461	1.250	1.591	2.379	3.970	4	5
WGX42500EW	●	2.500	3.008	1.250	1.591	2.379	3.970	5	5

Identification Details - Shell (Inch)

WGX F 4 2000 R

1 Cutter Series 2 M: Fine Pitched / F: Extra-Fine Pitched 3 Insert Series 4 Diameter (2.000") 5 Cutter Type

Identification Details - Shank (Inch)

WGX 4 2000 EW

1 Cutter Series 2 Insert Series 3 Diameter (2.000") 4 Endmill Type



WGX Series

Rake Angle	Radial	-20° to -24°	6 mm / 45°	
	Axial	20° to 22°		

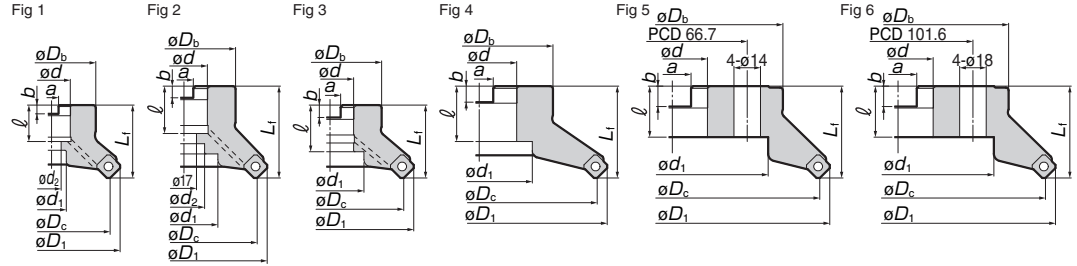

Body (Standard Pitch) - Metric

Cat. No.	Stock	Dimensions (mm)										No. of Teeth	Weight (kg)	Fig.
		ϕD_c	ϕD_1	ϕD_b	L_f	ϕd	a	b	ℓ	ϕd_1	ϕd_2			
WGX13040RS	★	40	52	32	40	16	8.4	5.6	18	14	9	3	0.3	1
WGX13050RS	★	50	62	40	40	22	10.4	6.3	20	18	11	3	0.4	1
WGX13063RS	★	63	76	50	40	22	10.4	6.3	20	18	11	4	0.6	1
WGX13080R	★	80	93	60	50	25.4	9.5	6	25	20	13	4	1.2	1
WGX13100R	★	100	113	70	63	31.75	12.7	8	32.5	46	28	5	2.3	2
WGX13125R	★	125	138	80	63	38.1	15.9	10	35.5	55	30	6	2.9	1
WGX13160R	★	160	173	100	63	50.8	19	11	38	72	-	7	4.5	4
WGX13200R	★	200	213	150	63	47.625	25.4	14	35	130	-	8	7.1	6
WGX13250R	★	250	263	190	63	47.625	25.4	14	35	150	-	10	11.2	6

Body (Fine Pitch) - Metric

Cat. No.	Stock	Dimensions (mm)										No. of Teeth	Weight (kg)	Fig.
		ϕD_c	ϕD_1	ϕD_b	L_f	ϕd	a	b	ℓ	ϕd_1	ϕd_2			
WGXM13050RS	★	50	62	40	40	22	10.4	6.3	20	18	11	4	0.4	1
WGXM13063RS	★	63	77	50	40	22	10.4	6.3	20	18	11	5	0.6	1
WGXM13080R	★	80	94	60	50	25.4	9.5	6	25	20	13	6	1.1	1
WGXM13100R	★	100	114	70	63	31.75	12.7	8	32.5	46	28	7	2.2	2
WGXM13125R	★	125	139	80	63	38.1	15.9	10	35.5	55	30	8	2.9	1
WGXM13160R	★	160	174	100	63	50.8	19	11	38	72	-	10	4.5	4
WGXM13200R	★	200	214	150	63	47.625	25.4	14	35	130	-	12	7.0	6
WGXM13250R	★	250	264	190	63	47.625	25.4	14	35	150	-	14	11.1	6

Body (Extra-Fine Pitch) - Metric

Cat. No.	Stock	Dimensions (mm)										No. of Teeth	Weight (kg)	Fig.
		ϕD_c	ϕD_1	ϕD_b	L_f	ϕd	a	b	ℓ	ϕd_1	ϕd_2			
WGXF13050RS	★	50	62	40	40	22	10.4	6.3	20	18	11	5	0.4	1
WGXF13063RS	★	63	77	50	40	22	10.4	6.3	20	18	11	6	0.6	1
WGXF13080R	★	80	94	60	50	25.4	9.5	6	25	20	13	8	1.1	1
WGXF13100R	★	100	114	70	63	31.75	12.7	8	32.5	46	28	10	2.1	2
WGXF13125R	★	125	139	80	63	38.1	15.9	10	35.5	55	30	12	2.8	1
WGXF13160R	★	160	174	100	63	50.8	19	11	38	72	-	16	4.5	4
WGXF13200R	★	200	214	150	63	47.625	25.4	14	35	130	-	20	6.9	6
WGXF13250R	★	250	264	190	63	47.625	25.4	14	35	150	-	24	11.0	6

★: Worldwide Warehouse Item

Sizes $\phi 160$ mm or above do not have coolant holes

Body (Shank Type)

Cat. No.	Stock	Dimensions (mm)						No. of Teeth
		ϕD_c	ϕD_1	ϕD_s	L_f	ℓ_s	L	
WGX13032EW	★	32	44	32	40	85	125	3
WGX13040EW	★	40	52	32	40	85	125	3
WGX13050EW	★	50	62	32	40	85	125	4
WGX13063EW	★	63	76	32	40	85	125	5

★: Worldwide Warehouse Item

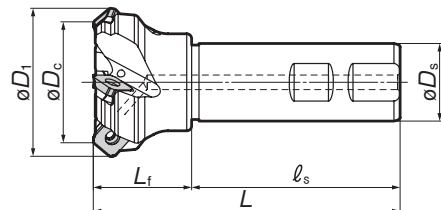

Identification Details:

WGX M 13 050 R S

1 Cutter Series 2 M: Fine Pitched / F: Extra-Fine Pitched 3 Insert Size 4 Cutter 5 Direction 6 Metric Bore



Indexable Milling
Shoulder Milling
Face Milling
High Feed Milling
Multi-purpose
Modular Tooling
UFO & SumiMill
Discontinued

WGX Recommended Cutting Conditions							
ISO	Material	Hardness	Grade	Depth of Cut			Feed per Tooth
				.002 -.050	.050 - .125	.125 & over	
P	Low and Medium Carbon Steels	<250 Bhn	ACP100	775-1300	725-1250	675-1200	.006-.015
			ACP200	725-1200	675-1150	600-1125	.006-.015
			ACP300	675-1075	650-1025	525-925	.006-.015
	Medium Carbon Alloy Steels	<250 Bhn	ACP100	600-975	575-950	550-900	.006-.015
			ACP200	550-900	525-900	500-875	.006-.015
			ACP300	525-875	500-825	475-800	.006-.015
	Medium-High Carbon Steels	<250 Bhn	ACP100	600-975	575-950	550-900	.006-.015
			ACP200	575-950	550-925	500-875	.006-.015
			ACP300	550-925	525-900	525-850	.006-.015
	Free Machining Steels and Alloys	<250 Bhn	ACP100	775-1300	700-1250	675-1200	.006-.015
			ACP200	750-1275	675-1225	650-1150	.006-.015
			ACP300	675-1075	650-1050	650-1025	.006-.015
	Tool Steels	<250 Bhn	ACP100	475-820	450-790	425-750	.006-.012
			ACP200	450-800	435-775	400-725	.006-.012
			ACP300	435-785	425-760	400-715	.006-.012
		Bhn 220 - 350	ACP100	425-775	400-735	400-700	.004-.012
			ACP200	415-750	400-725	375-690	.004-.012
			ACP300	405-700	410-690	375-680	.004-.012
>33 Hrc	ACP100	325-650	300-630	300-590	.004-.012		
	ACP200	315-640	300-625	300-580	.004-.012		
M	Martensitic and Ferritic Stainless Steels	<250 Bhn	ACM300	535-850	520-820	275-800	.004-.012
			ACM300	525-825	515-800	250-775	.004-.012
		>250 Bhn	ACM200	350-800	325-775	300-750	.004-.012
	Austenitic and Precipitation Hardening Stainless Steels	<250 Bhn	ACM300	500-740	475-720	450-675	.004-.012
		>250Bhn	ACM200	250-750	225-725	200-700	.004-.012
K	Grey Cast Iron	>250 Bhn	ACK200	600-950	525-825	490-800	.004-.012
			ACK300	500-850	475-775	450-750	.004-.012
		<250 Bhn	ACK200	700-1050	625-925	590-900	.004-.015
	Ductile Iron	>250 Bhn	ACK300	600-950	575-875	550-850	.004-.015
			ACK200	600-925	550-875	490-800	.004-.012
			ACK300	550-825	500-775	450-750	.004-.012
S	Exotic Alloys: Inconel, Hastalloy, Waspalloy, etc.	>300Bhn	ACM200	125-550	110-500	95-450	.004-.010
			ACM300	100-160	70-150	60-135	.004-.010
N	Non-Ferrous Material		H1 DL1000	1000-4000	1000-4000	1000-4000	.006-.015

WGX + DGC Comparison

Needs	Surface Finish	Cutting Force	High Feed Rate	Insert Strength	Chip Evacuation	Cost Per Edge	General Versatility
Recommend	WGX	WGX	DGC	DGC	WGX	DGC	WGX





■ Features & Benefits

Improved reliability and quality

Improved coating and insert runout provides stability of life for production. An excellent lineup of Inserts with optimized chamfers to prevent burrs improves surface finish.

Superior economy

With the same sharpness at 3mm or less of similar one-sided inserts, you get twice the corners. Also, the cutter body holds both the ONMT & SNMT inserts, allowing up to 16 corners.

Extensive Lineup

A wide range of diameters (2.000" to 10.000") and pitches (Normal, Fine, Extra Fine), inch and metric sizes, allows you to choose what you need for your application.

WGX + DGC Comparison

Needs	Surface Finish	Cutting Force	High Feed Rate	Insert Strength	Chip Evacuation	Cost Per Edge	General Versatility
Recommend	WGX	WGX	DGC	DGC	WGX	DGC	WGX

Cutting performance: DGC vs. WGC

Work material : Cr-Mo Steel(SCM435)
Cutting conditions : vc= 500 SFM fz=.012 IPT
Tool dia: 4.00"

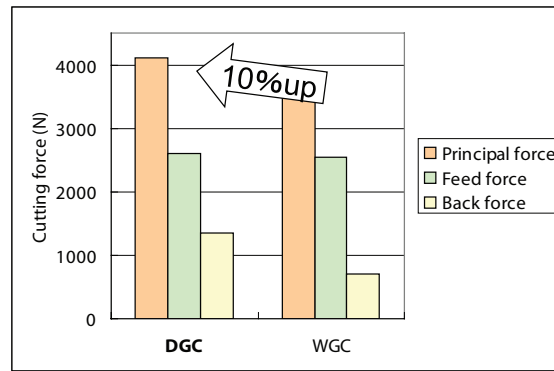
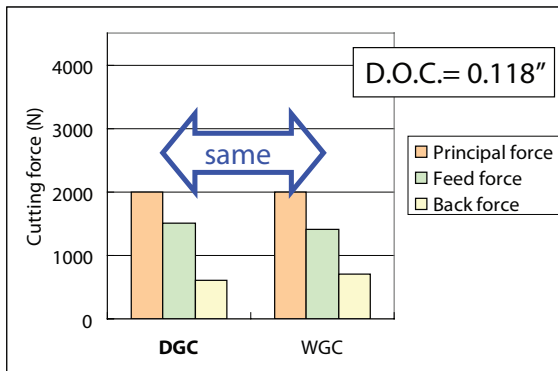

General Cutting Conditions

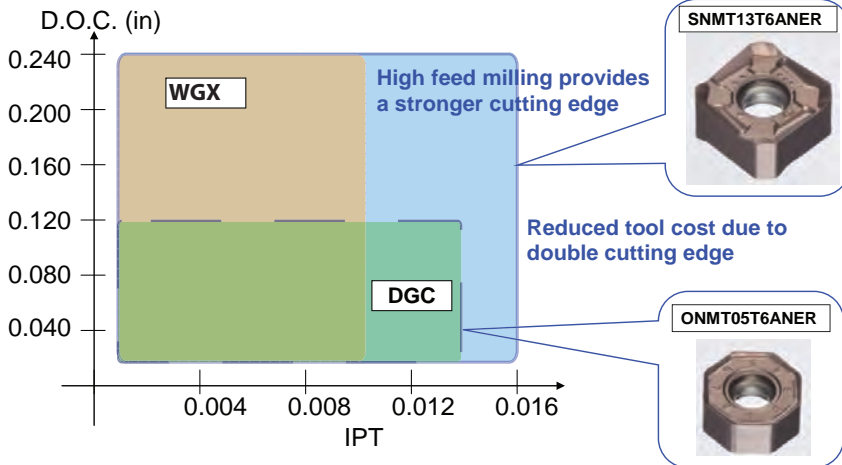

Edge Preparations

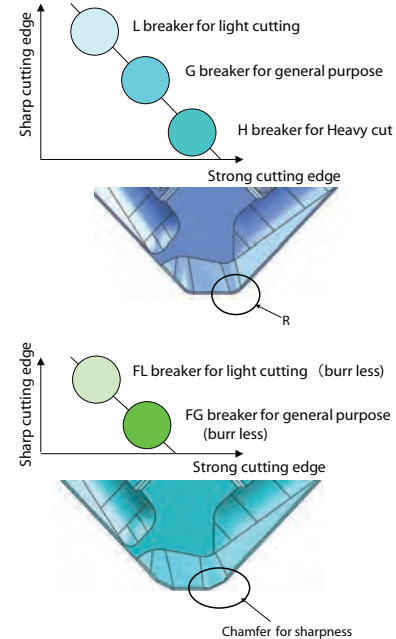

Indexable Milling
Shoulder Milling
Face Milling
High Feed Milling
Multi-purpose
Modular Tooling
UFO & SumiMill
Discontinued

DGC Variation of Diameter of Insert

Both SNMT and ONMT inserts can be used on the same cutter body

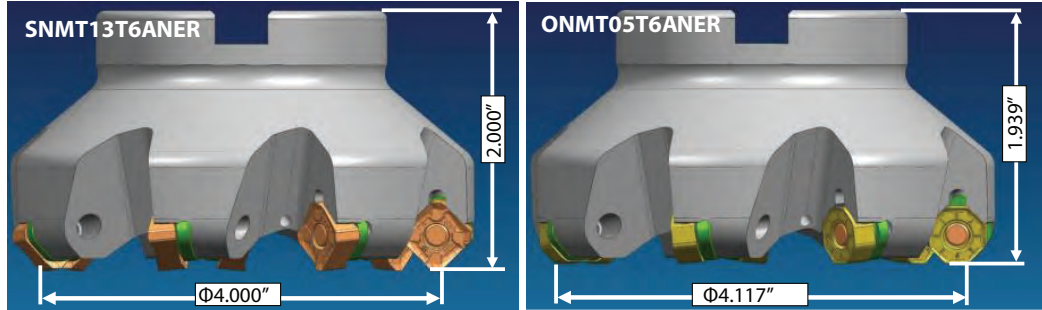

EX.	4.000"	# of cutting edges	Tool dia.	Cutter height	Max D.O.C
SNMT		8	4"	2"	6mm 0.236"
ONMT		16	4.117"	1.939"	3mm 0.118"

Machining stability with new Super ZX coating

Super multi-layered new super ZX coating improves wear resistance, toughness, and anti-adhesion.

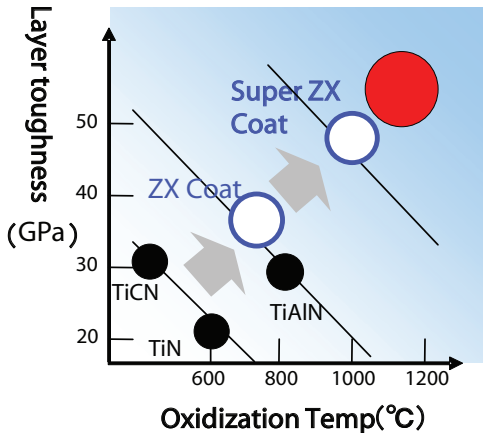

Proper Seating of the ONMT Insert

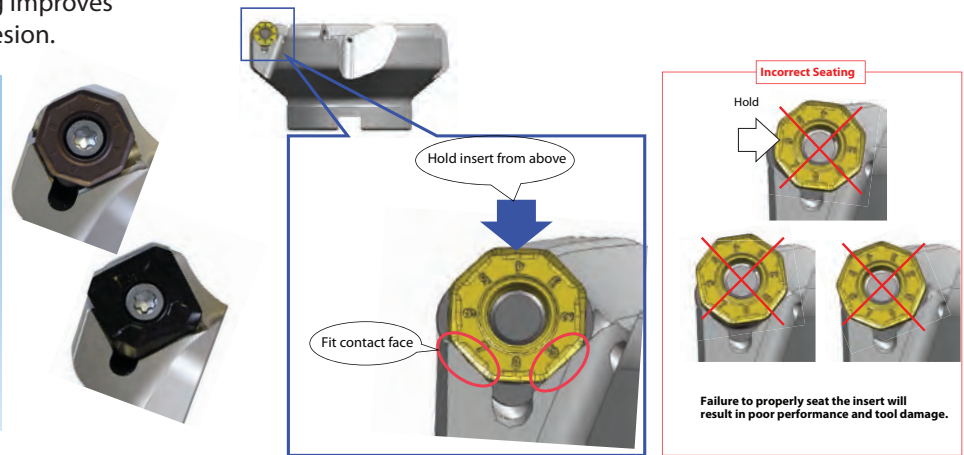

Parts

Seat	Seat Screw	L Type Wrench	Insert Screw	Spanner	Anti-seizure Cream
DGCS13R	BW0609F	LH040	BFTX0412IP	TRDR15IP	SUMI-P

(Optional)

Insert Screw(*)
BFTX0418IP

*Corners can be changed simply by loosening the screw. (Only applies to DGC / DGCM types with body size φ 80 or above.)



DUALMILL DGC4000 - INCH

DualMill DGC Series

Double-sided 45° Lead Face Mill

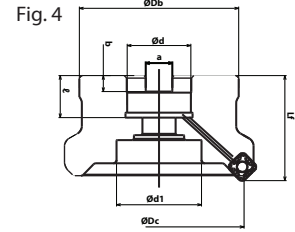
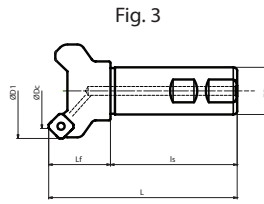
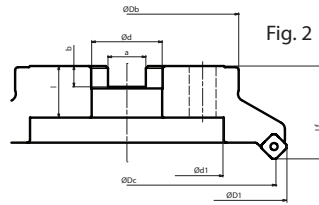
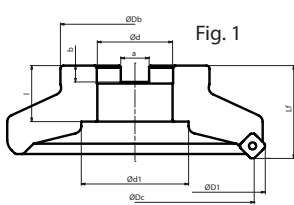

Rake Angle: Radial: -10° Axial: -5°

DGC Cutter Bodies - Coarse Pitch - INCH

Catalog Number	Stock	ϕD_c	ϕD_1	ϕD_b	L_f	ϕD	ϕd_1	a	b	ℓ	Teeth	Fig.
DGC42000R	●	2.000	2.567	1.500	1.750	0.750	0.609	0.312	0.190	0.750	3	1
DGC42500R	●	2.500	3.067	1.750	1.750	1.000	0.797	0.375	0.220	0.750	4	1
DGC43000R	●	3.000	3.567	2.250	1.750	1.000	0.787	0.375	0.220	0.750	4	1
DGC44000R	●	4.000	4.567	2.870	2.000	1.250	1.000	0.500	0.280	0.750	5	1
DGC44000R-1.50	●	4.000	4.000	3.750	2.500	1.500	2.000	0.625	0.380	1.000	5	4
DGC45000R	●	5.000	5.567	3.750	2.500	1.500	2.000	0.625	0.380	1.000	6	1
DGC46000R	●	6.000	6.567	4.380	2.500	1.500	2.000	0.625	0.380	1.060	7	2
DGC48000R	●	8.000	8.567	5.906	2.500	2.500	5.118	1.000	0.560	1.594	8	2
DGC410000R	●	10.000	10.567	7.480	2.756	2.500	6.299	1.000	0.531	1.575	10	2

DGC Cutter Bodies - Fine Pitch - INCH

Catalog Number	Stock	ϕD_c	ϕD_1	ϕD_b	L_f	ϕD	ϕd_1	a	b	ℓ	Teeth	Fig.
DGCM42000R	●	2.000	2.567	1.500	1.750	0.750	0.609	0.312	0.190	0.750	4	1
DGCM42500R	●	2.500	3.067	1.750	1.750	1.000	0.797	0.375	0.220	0.750	5	1
DGCM43000R	●	3.000	3.567	2.250	1.750	1.000	0.787	0.375	0.220	0.750	6	1
DGCM44000R	●	4.000	4.567	2.870	2.000	1.250	1.000	0.500	0.280	0.750	7	1
DGCM44000R-1.50	●	4.000	4.000	3.750	2.500	1.500	2.000	0.625	0.380	1.000	7	4
DGCM45000R	●	5.000	5.567	3.750	2.500	1.500	2.000	0.625	0.380	1.000	8	1
DGCM46000R	●	6.000	6.567	4.380	2.500	1.500	2.000	0.625	0.380	1.060	10	2
DGCM48000R	●	8.000	8.567	5.906	2.500	2.500	5.118	1.000	0.560	1.594	12	2

DGC Cutter Bodies - Extra Fine Pitch - INCH

Catalog Number	Stock	ϕD_c	ϕD_1	ϕD_b	L_f	ϕD	ϕd_1	a	b	ℓ	Teeth	Fig.
DGCF42000R	●	2.000	2.567	1.500	1.750	0.750	0.609	0.312	0.190	0.750	5	1
DGCF42500R	●	2.500	3.067	1.750	1.750	1.000	0.797	0.375	0.220	0.750	6	1
DGCF43000R	●	3.000	3.567	2.250	1.750	1.000	0.787	0.375	0.220	0.750	8	1
DGCF44000R	●	4.000	4.567	2.870	2.000	1.250	1.000	0.500	0.280	0.750	10	1
DGCF44000R-1.50	●	4.000	4.000	3.750	2.500	1.500	2.000	0.625	0.380	1.000	10	4
DGCF45000R	●	5.000	5.567	3.750	2.500	1.500	2.000	0.625	0.380	1.000	12	1
DGCF46000R	●	6.000	6.567	4.380	2.500	1.500	2.000	0.625	0.380	1.060	14	2
DGCF48000R	●	8.000	8.567	5.906	2.500	2.500	5.118	1.000	0.560	1.594	16	2

DGC Cutter Bodies - Shank - INCH

Catalog Number	Stock	ϕD_c	ϕD_1	ϕD_b	L_f	ℓ_s	L	Teeth	Fig.
DGC42000EW	●	2.000	2.567	1.250	1.591	2.379	3.970	4	3
DGC42500EW	●	2.000	2.567	1.250	1.591	2.379	3.970	5	3

PLEASE NOTE: For 40, 50 and 63mm, arbor hole is standard in metric sizes, not inch sizes.

Catalog Number	P		K		M		H	
	ACP100	ACP200	ACP300	T4500A	ACK200	ACK300	ACM200	ACM300
SNMT13T6ANER-L	●	●	●	●	●	●	●	●
SNMT13T6ANER-G	●	●	●	●	●	●	●	●
SNMT13T6ANER-H	●	●	●	●	●	●	●	●
SNMT13T6ANER-FL	●	●	●	●	●	●	●	●
SNMT13T6ANER-FG	●	●	●	●	●	●	●	●
SNET13T6ANER-L							●	●
SNET13T6ANER-G							●	●
SNET13T6ANER-FL							●	●
SNET13T6ANER-FG							●	●
SNET13T6ANFR-S								●
ONMT05T6ANER-L	●	●	●	●	●	●	●	●
ONMT05T6ANER-G	●	●	●	●	●	●	●	●
ONET05T6ANER-L							●	●
ONET05T6ANER-G							●	●
XNEU13T6ANEN-W	●	●	●	●	●	●	●	●

●: USA Stocked Item

See pages 613-615
for recommended
running parameters

Max. Depth of Cut
SNMT: 6mm (.236")
ONMT: 3mm (.188")

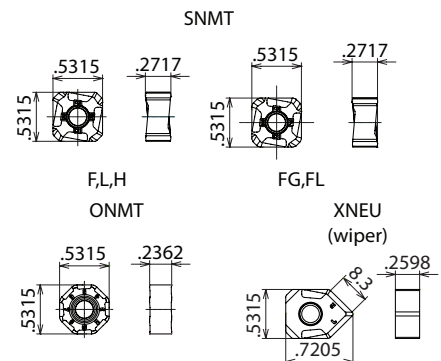

Rake Angle	Radial	-10°
	Axial	-5°

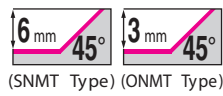

P	M	K	N	N	S	H
Steel	Aluminum	Cast Iron	Inconel	Titanium	Exotic Alloy	High Speed Steel

DUALMILL DGC13000 - METRIC

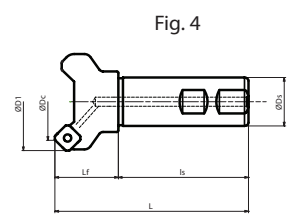
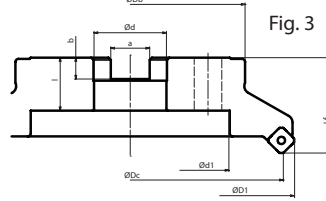
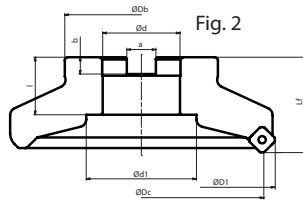
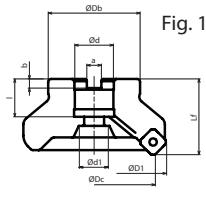

Rake Angle: Radial: -10° Axial: -5°

DGC Cutter Bodies - Coarse Pitch - METRIC

Catalog Number	Stock	φDc	φD1	φDb	Lf	φD	φD1	a	b	ℓ	Teeth	Fig.
DGC13040RS	●	40	54	36	40	16	13.5	8.4	5.6	18	3	1
DGC13050RS	●	50	64	40	40	22	18	10.4	6.3	20	3	1
DGC13063RS	●	63	77	50	40	22	18	10.4	6.3	20	4	1
DGC13080R	●	80	94	60	50	25.4	20	9.5	7	25	4	1
DGC13100R	●	100	114	70	63	31.75	28	12.7	8.5	32.5	5	1
DGC13125R	●	125	139	80	63	38.1	55	15.9	9.5	35.5	6	1
DGC13160R	●	160	174	100	63	50.8	72	19	9.5	38	7	2
DGC13200R	●	200	214	150	63	47.625	130	25.4	14	35	8	3
DGC13250R	●	250	264	190	63	47.625	150	25.4	14	35	10	3

DGC Cutter Bodies - Fine Pitch - METRIC

Catalog Number	Stock	φDc	φD1	φDb	Lf	φD	φD1	a	b	ℓ	Teeth	Fig.
DGCM13050RS	●	50	64	40	40	22	18	10.4	6.3	20	4	1
DGCM13063RS	●	63	77	50	40	22	18	10.4	6.3	20	5	1
DGCM13080R	●	80	94	60	50	25.4	20	9.5	7	25	6	1
DGCM13100R	●	100	114	70	63	31.75	28	12.7	8.5	32.5	7	1
DGCM13125R	●	125	139	80	63	38.1	55	15.9	9.5	35.5	8	1
DGCM13160R	●	160	174	100	63	50.8	72	19	9.5	38	10	2
DGCM13200R	●	200	214	150	63	47.625	130	25.4	14	35	12	3
DGCM13250R	●	250	264	190	63	47.625	150	25.4	14	35	14	3

DGC Cutter Bodies - Extra Fine Pitch - METRIC

Catalog Number	Stock	φDc	φD1	φDb	Lf	φD	φD1	a	b	ℓ	Teeth	Fig.
DGCF13050RS	●	50	64	40	40	22	18	10.4	6.3	20	5	1
DGCF13063RS	●	63	77	50	40	22	18	10.4	6.3	20	6	1
DGCF13080R	●	80	94	60	50	25.4	20	9.5	7	25	8	1
DGCF13100R	●	100	114	70	63	31.75	28	12.7	8.5	32.5	10	1
DGCF13125R	●	125	139	80	63	38.1	55	15.9	9.5	35.5	12	1
DGCF13160R	●	160	174	100	63	50.8	72	19	9.5	38	14	2
DGCF13200R	●	200	214	150	63	47.625	130	25.4	14	35	16	3
DGCF13250R	●	250	264	190	63	47.625	150	25.4	14	35	18	3

DGC Cutter Bodies - Shank - METRIC

Catalog Number	Stock	φDc	φD1	φDb	Lf	ℓs	L	Teeth	Fig.
DGC13040EW	●	40	54	32	40	85	125	3	4
DGC13050EW	●	50	64	32	40	85	125	3	
DGC13063EW	●	63	77	32	40	85	125	4	

See pages 613-615
for recommended
running parameters

PLEASE NOTE: For 40, 50 and 63mm, arbor hole is standard in metric sizes, not inch sizes.

Catalog Number	Inserts						
	P	K	M	H	H		
SNMT13T6ANER-L	●	●	●	●	●	●	●
SNMT13T6ANER-G	●	●	●	●	●	●	●
SNMT13T6ANER-H	●	●	●	●	●	●	●
SNMT13T6ANER-FL	●	●	●	●	●	●	●
SNMT13T6ANER-FG	●	●	●	●	●	●	●
SNET13T6ANER-L	●	●	●	●	●	●	●
SNET13T6ANER-G	●	●	●	●	●	●	●
SNET13T6ANER-FL	●	●	●	●	●	●	●
SNET13T6ANER-FG	●	●	●	●	●	●	●
SNET13T6ANFR-S	●	●	●	●	●	●	●
ONMT05T6ANER-L	●	●	●	●	●	●	●
ONMT05T6ANER-G	●	●	●	●	●	●	●
ONET05T6ANER-L	●	●	●	●	●	●	●
ONET05T6ANER-G	●	●	●	●	●	●	●
XNEU13T6ANEN-W	●	●	●	●	●	●	●

Max. Depth of Cut
SNMT: 6mm (.236")
ONMT: 3mm (.188")

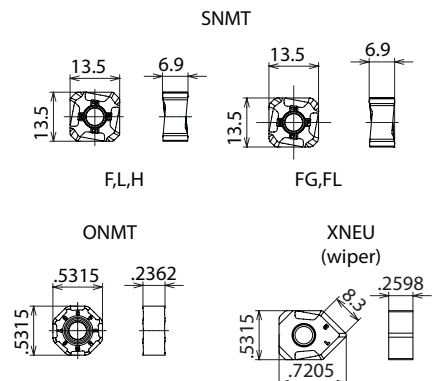

●: USA Stocked Item



DFC Series

DFC Series

High Efficiency, Double-sided 90° Milling Cutter

DFC Mill Features & Benefits

- High toughness insert design enables stable cutting and high efficiency machining with high feed rate
- Optimized machining accuracy by separating the insert contact areas and the cutting edges
- Large lineup for DFC available from 1" through 8" in standard, fine pitch and extra-fine pitch styles

NEW



Insert Characteristics

Precise repositioning of inserts due to thick supporting area

Optimized cutting edge yields excellent machining accuracy

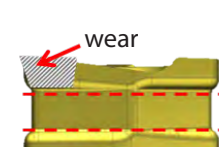
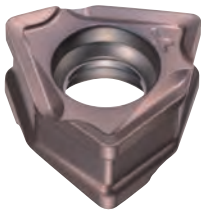

XNMU side view



conventional insert side view

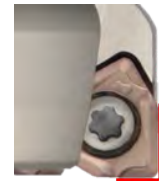

Squareness Performance

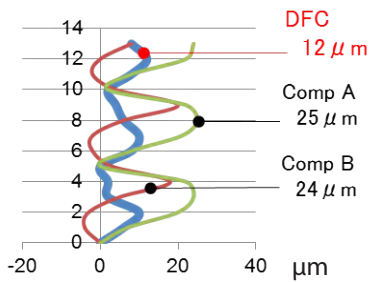

Work material : 1049 steel

Cutting Conditions: $v_c=650$ SFM $f_z=.0039$ IPT
 $D_c=63$ mm
 $a_p=.197"$ x 3 pass, $a_e=.197"$

Wear Resistance Chart

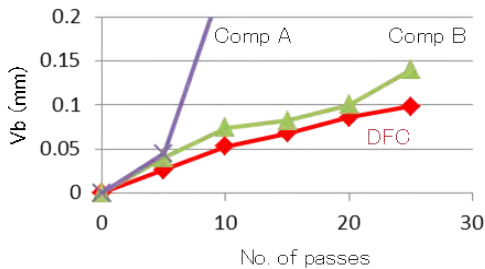

Work material: 1049 steel
 Cutting Conditions: $v_c=650$ SFM $f_z=.0079$ IPT
 $D_c=100$ mm cutter
 $a_p=.118"$, $a_e=3.346"$

Surface Finish Graph

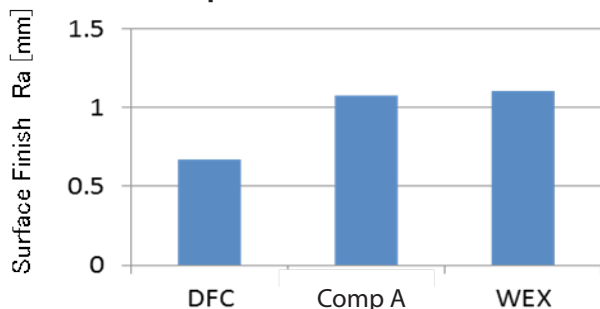

Work material: 1049 steel
 Cutting Conditions: $v_c=650$ SFM $f_z=.0079$ IPT
 $D_c=100$ mm cutter
 $a_p=.118"$, $a_e=3.346"$

Cutting Edge Strength

	Feed Per Tooth (in/t)		
	0.012	0.016	0.020
DFC	•	•	•
Comp A	•	damage	
Comp B	damage		

Work material: 1049 steel with holes
 Cutting Conditions: $v_c=650$ SFM $f_z=.0079$ IPT
 $D_c=100$ mm cutter
 $a_p=.118"$, $a_e=2.047"$ x 3 pass

Cutting Force

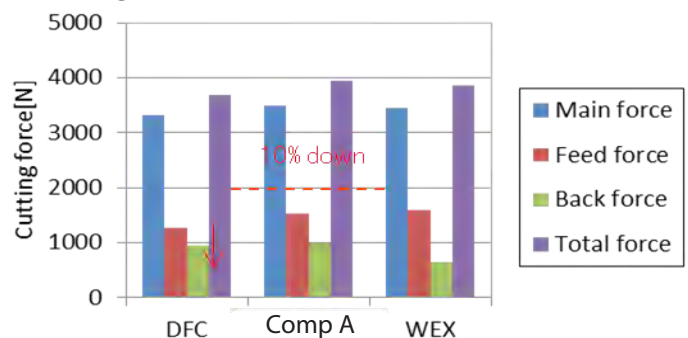

Work material: 1049 steel
 Cutting Conditions: $v_c=650$ SFM $f_z=.0079$ IPT
 $D_c=100$ mm cutter
 $a_p=.118"$, $a_e=2.953"$



Indexable Milling
 Shoulder Milling
 Face Milling
 High Feed Milling
 Multi-purpose
 Modular Tooling
 UFO & SumiMill
 Discontinued

High Efficiency, Double-sided 90° Milling Cutter

Inserts

NEW

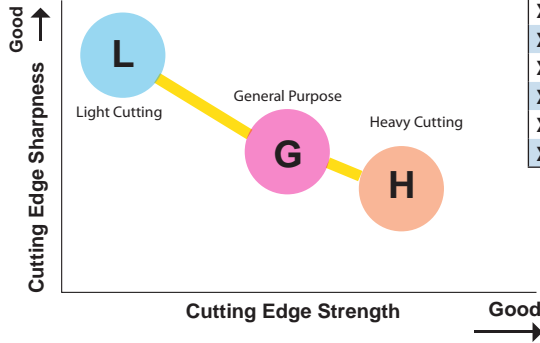
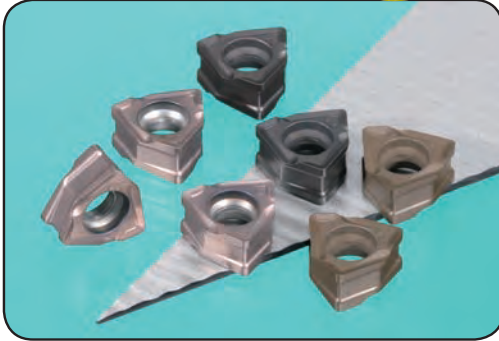

XNMU Inserts

Max. Depth of Cut: 6mm (.236")

Catalog Number	P		K		M		Radius
	ACP100	ACP200	ACK200	ACK300	ACM200	ACM300	
XNMU060604PNER-L	●	●	●	●	●	●	.016
XNMU060608PNER-L	●	●	●	●	●	●	.031
XNMU060604PNER-G	●	●	●	●	●	●	.016
XNMU060608PNER-G	●	●	●	●	●	●	.031
XNMU060612PNER-G	●	●	●	●	●	●	.047
XNMU060616PNER-G	●	●	●	●	●	●	.063
XNMU060608PNER-H	●	●	●	●	●	●	.031
XNMU060612PNER-H	●	●	●	●	●	●	.047
XNMU060616PNER-H	●	●	●	●	●	●	.063

● USA stocked item

Material	P10/M10/C7	P20/M20/C6	P30/M30/C5A	P40/M40/C5
Steel	ACP100			
	ACP200			
	ACP300			
Stainless Steel				
Material	K01	K10	K20	K30
Cast Iron	ACK200			
	ACK300			
Material	Wear Resistance		Fracture Resistance	
Stainless Steel	ACM200			
Exotic Material	ACM300			

Work Material	Steel, Cast Iron		
	L type	G type	H type
Chip breaker			
Feature	Low cutting force	General purpose	Strong edge
Cutting edge figure			
Application	Light cut, low rigidity milling and reduced burr formation	Main breaker, General purpose to interrupted milling	Roughing, heavy interrupted and hardness steel milling.

Running Conditions

ISO	Work Material	Hardness	Cutting Speed (SFM)			Feed Rate (in./t)			D.O.C. (in.)	Grade
			Min.	Optimum	Max.	Min.	Optimum	Max.		
P	General Steel	180 ~ 280HB	500	650	820	0.004	0.008	0.012	<0.236	ACP200 ACP300
	Soft Steel	<180HB	600	820	1,150	0.006	0.010	0.014	< 0.236	ACP200 ACP300
	Die Steel	200 ~ 220HB	330	500	650	0.004	0.007	0.010	< 0.157	ACP200 ACP300
M	PH Stainless Steel	>220HB	300	500	750	0.004	0.007	0.010	<0.196	ACM200
	Austenitic Stainless	<250HB	525	675	820	0.005	0.007	0.010	<0.236	ACM300
K	Cast Iron	250HB	500	750	1150	0.004	0.008	0.012	<0.236	ACK200 ACK300



INCH Lineup DFC

DFC - Inch Lineup

High Efficiency, Double-sided 90° Milling Cutter



NEW

Figure 1

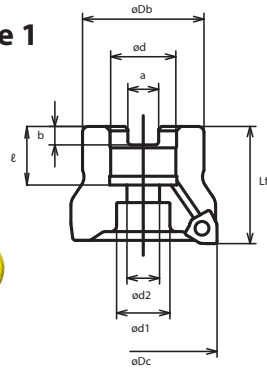
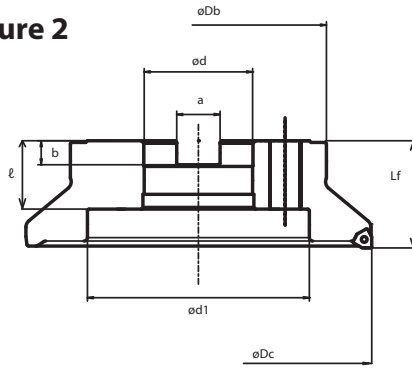

Figure 2



Body (Standard Pitch) - Inch

Cat. No.	Stock	Dimensions (in.)									No. of Teeth	Weight (lbs)	Fig.
		øDc	øDb	Lf	ød	a	b	ℓ	ød1	ød2			
DFC22000R	●	2.000	1.500	1.750	0.750	0.312	0.190	0.750	0.609	0.406	4	0.75	1
DFC22500R	●	2.500	1.750	1.750	1.000	0.375	0.220	0.750	0.797	0.531	5	1.08	1
DFC23000R	●	3.000	2.250	1.750	1.000	0.375	0.220	0.750	0.797	0.531	6	1.81	1
DFC24000R	●	4.000	2.870	2.000	1.250	0.500	0.280	0.750	1.000	0.656	6	3.84	1
DFC24000R-1.50	●	4.000	3.150	2.500	1.500	0.625	0.380	1.000	2.000	1.181	6	4.76	1
DFC25000R	●	5.000	3.750	2.500	1.500	0.625	0.380	1.000	2.000	1.181	7	7.87	1
DFC26000R	●	6.000	4.380	2.500	1.500	0.625	0.380	1.000	2.000	1.181	8	11.64	1
DFC28000R	●	8.000	5.906	2.500	2.500	1.000	0.560	1.594	5.118	-	10	15.00	2

Body (Fine Pitch) - Inch

DFCM22000R	●	2.000	1.500	1.750	0.750	0.312	0.190	0.750	0.609	0.406	5	0.75	1
DFCM22500R	●	2.500	1.750	1.750	1.000	0.375	0.220	0.750	0.797	0.531	6	1.05	1
DFCM23000R	●	3.000	2.250	1.750	1.000	0.375	0.220	0.750	0.797	0.531	8	1.79	1
DFCM24000R	●	4.000	2.870	2.000	1.250	0.500	0.280	0.750	1.000	0.656	10	3.79	1
DFCM24000R-1.50	●	4.000	3.150	2.500	1.500	0.625	0.380	1.000	2.000	1.181	10	4.67	1
DFCM25000R	●	5.000	3.750	2.500	1.500	0.625	0.380	1.000	2.000	1.181	12	7.78	1
DFCM26000R	●	6.000	4.380	2.500	1.500	0.625	0.380	1.000	2.000	1.181	14	11.55	1
DFCM28000R	●	8.000	5.906	2.500	2.500	1.000	0.560	1.594	5.118	-	15	14.79	2

Body (Extra-Fine Pitch) - Inch

DFCF22000R	●	2.000	1.500	1.750	0.750	0.312	0.190	0.750	0.609	0.406	6	0.71	1
DFCF22500R	●	2.500	1.750	1.750	1.000	0.375	0.220	0.750	0.797	0.531	7	1.03	1
DFCF23000R	●	3.000	2.250	1.750	1.000	0.375	0.220	0.750	0.797	0.531	9	1.76	1
DFCF24000R	●	4.000	2.870	2.000	1.250	0.500	0.280	0.750	1.000	0.656	11	3.64	1
DFCF24000R-1.50	●	4.000	3.150	2.500	1.500	0.625	0.380	1.000	2.000	1.181	11	4.54	1
DFCF25000R	●	5.000	3.750	2.500	1.500	0.625	0.380	1.000	2.000	1.181	14	7.54	1
DFCF26000R	●	6.000	4.380	2.500	1.500	0.625	0.380	1.000	2.000	1.181	16	11.29	1
DFCF28000R	●	8.000	5.906	2.500	2.500	1.000	0.560	1.594	5.118	-	20	14.59	2

● USA stocked item



Body (Shank Type)

Cat. No.	Stock	Dimensions (in.)					No. of Teeth	Weight (lbs)
		øDc	øDs	Lf	ℓs	L		
DFC21000EW	●	1.000	1.000	2.060	2.281	4.341	2	0.77
DFC21250EW	●	1.250	1.250	2.060	2.281	4.341	3	1.26
DFC21500EW	●	1.500	1.250	2.060	2.281	4.341	3	1.52
DFC22000EW	●	2.000	1.250	2.060	2.281	4.341	4	1.72
DFC22500EW	●	2.500	1.250	2.060	2.281	4.341	5	2.12
DFCM21500EW	●	1.500	1.250	2.060	2.281	4.341	4	1.50
DFCM22000EW	●	2.000	1.250	2.060	2.281	4.341	5	1.70
DFCM22500EW	●	2.500	1.250	2.060	2.281	4.341	7	2.07

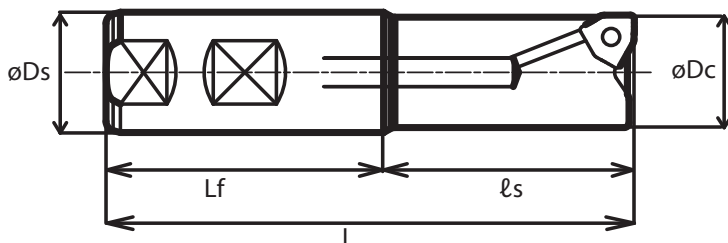
DFC Endmill Inch Lineup



Hardware

Insert Screw	Insert Wrench	Coolant Through Bolts	
 BFTX03512IP	 TRDR15IP Torque: 3.0 N·m	Catalog Number	Cutter Size
		BFXH 3/8 x 1	2.00"
		BFXH 1/2 x 1 1/4	2.50"
		BFXH 1/2 x 1 1/4	3.00"
		BFXH 5/8 x 1 1/4	4.00"
		BFXH 3/4 x 2	5.00"



High Efficiency, Double-sided 90° Milling Cutter

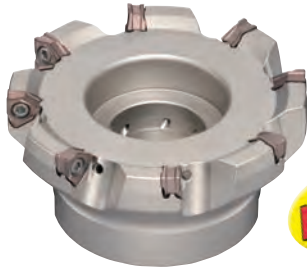

NEW

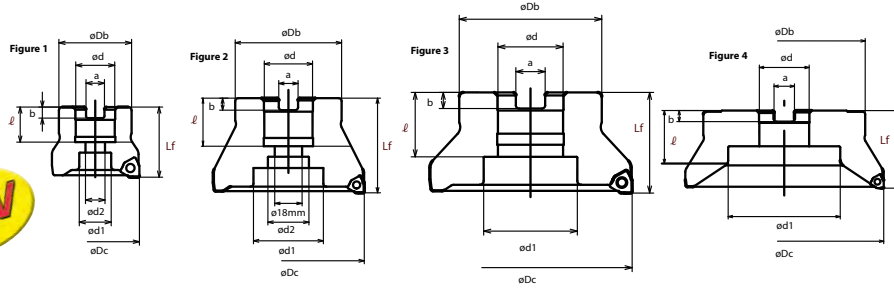

Body (Standard Pitch) - Metric

Cat. No.	Stock	Dimensions (mm)									No. of Teeth	Weight (kg)	Fig.
		øD _c	øD _b	L _f	ød	a	b	ℓ	ød ₁	ød ₂			
DFC09050RS	★	50	41	40	22	10.4	6.3	20	18	11	4	0.3	1
DFC09063RS	★	63	50	40	22	10.4	6.3	20	18	11	4	0.5	1
DFC09080RS	★	80	55	50	27	12.4	7	22	20	14	5	1	1
DFC09100RS	★	100	70	50	32	14.4	8	26	46	32	6	1.4	3
DFC09125RS	★	125	80	63	40	16.4	9	29	52	29	7	2.8	1
DFC09160RS	★	160	100	63	40	16.4	9	29	90	-	8	4.6	4
DFC09080R	★	80	55	50	25.4	9.5	6	25	20	14	5	1	1
DFC09100R	★	100	70	63	31.75	12.7	8	32	27	18	6	2	2
DFC09125R	★	125	80	63	38.1	15.9	10	35.5	55	30	7	2.8	1
DFC09160R	★	160	100	63	50.8	19.1	11	38	72	-	8	3.6	4

Body (Fine Pitch) - Metric

DFCM09050RS	★	50	41	40	22	10.4	6.3	20	18	11	5	0.3	1
DFCM09063RS	★	63	50	40	22	10.4	6.3	20	18	11	6	0.5	1
DFCM09080RS	★	80	55	50	27	12.4	7	22	20	14	7	0.9	1
DFCM09100RS	★	100	70	50	32	14.4	8	26	46	32	8	1.4	3
DFCM09125RS	★	125	80	63	40	16.4	9	29	52	29	11	2.7	1
DFCM09160RS	★	160	100	63	40	16.4	9	29	90	-	12	4.5	4
DFCM09080R	★	80	55	50	25.4	9.5	6	25	20	14	7	0.9	1
DFCM09100R	★	100	70	63	31.75	12.7	8	32	27	18	8	1.9	2
DFCM09125R	★	125	80	63	38.1	15.9	10	35.5	55	30	11	2.7	1
DFCM09160R	★	160	100	63	50.8	19.1	11	38	72	-	12	3.5	4

Body (Extra-Fine Pitch) - Metric

DFCF09050RS	★	50	41	40	22	10.4	6.3	20	18	11	6	0.3	1
DFCF09063RS	★	63	50	40	22	10.4	6.3	20	18	11	7	0.5	1
DFCF09080RS	★	80	55	50	27	12.4	7	22	20	14	9	0.9	1
DFCF09100RS	★	100	70	50	32	14.4	8	26	46	32	11	1.3	3
DFCF09125RS	★	125	80	63	40	16.4	9	29	52	29	14	2.6	1
DFCF09160RS	★	160	100	63	40	16.4	9	29	90	-	16	4.6	4
DFCF09080R	★	80	55	50	25.4	9.5	6	25	20	14	9	0.9	1
DFCF09100R	★	100	70	63	31.75	12.7	8	32	27	18	11	1.9	2
DFCF09125R	★	125	80	63	38.1	15.9	10	35.5	55	30	14	2.7	1
DFCF09160R	★	160	100	63	50.8	19.1	11	38	72	-	16	3.5	4

★ worldwide warehouse item

Body (Shank Type)

Cat. No.	Stock	Dimensions (mm)					No. of Teeth
		øD _c	øD _s	L _f	ℓ _s	L	
DFC09025E	★	25	25	40	80	120	2
DFC09032E	★	32	32	50	80	130	2
DFC09040E	★	40	32	50	80	130	3
DFC09050E	★	50	32	50	80	130	3
DFC09050E-42	★	50	42	50	100	150	3
DFC09063E	★	63	32	50	80	130	4
DFC09063E-42	★	63	42	50	100	150	4
DFC09080E	★	80	32	50	80	130	5
DFC09080E-42	★	80	42	50	100	150	5
DFCM09032E	★	32	32	50	80	130	3
DFCM09040E	★	40	32	50	80	130	4
DFCM09050E	★	50	32	50	80	130	5
DFCM09050E-42	★	50	42	50	100	150	5
DFCM09063E	★	63	32	50	80	130	6
DFCM09063E-42	★	63	42	50	100	150	6
DFCM09080E	★	80	32	50	80	130	7
DFCM09080E-42	★	80	42	50	100	150	7

DFC Endmill Metric Lineup

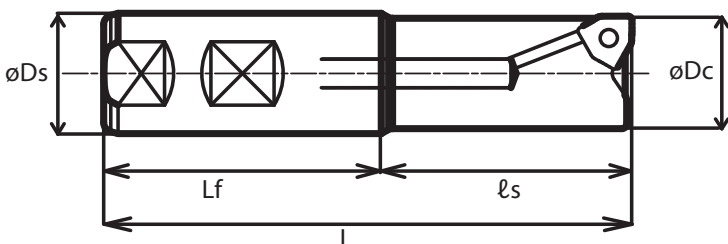
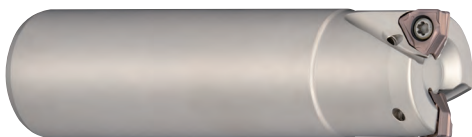

Features & Benefits

- Excellent surface finish capabilities
- Consists of fixed pocket inserts on the periphery
- Cartridges adjust easily and use the same insert as the periphery pockets
- All LNGX inserts have 8 cutting edges (12 when used with both right and left hand cutters)



Insert Features

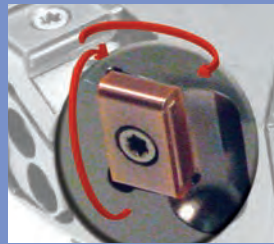
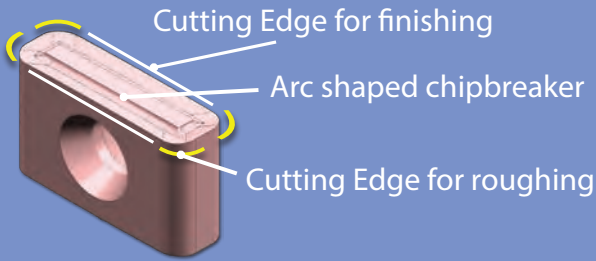

Four indexes can be used in the periphery pocket if the insert is rotated.

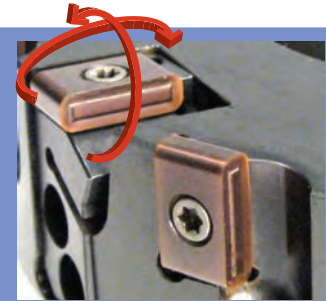

Flip the insert on its side and four indexes can also be used in the finishing cartridge.

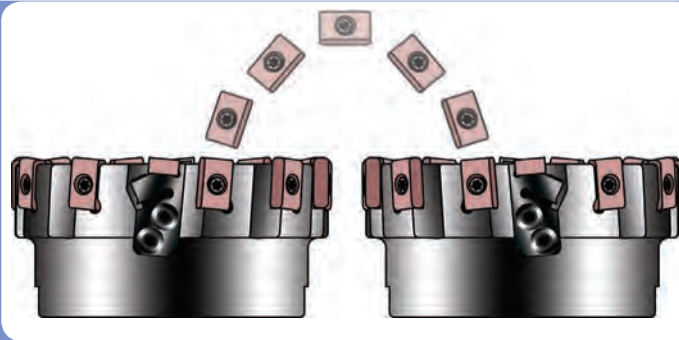

By switching the insert to a left hand cutter, **FOUR MORE ROUGHING EDGES** can now be used. A total of 12 indexes are possible when using both right and left hand cutters.*

*Left-handed cutters are made to order



Master Tool can provide custom-made milling cutters to accommodate your specific applications.

Roughing <50Rz	Semi-finishing <18Rz	Finishing <12.5Rz
45° 	45° w/wiper 	90° 



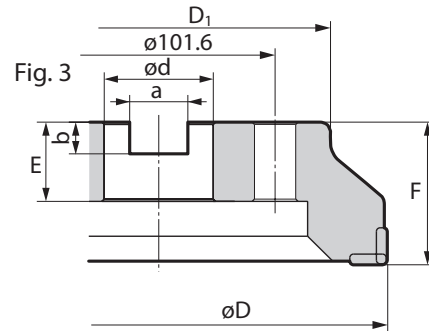
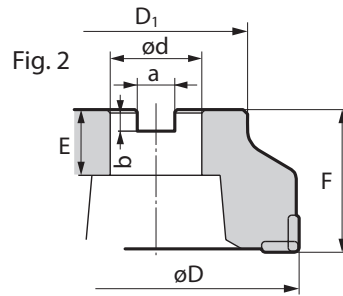
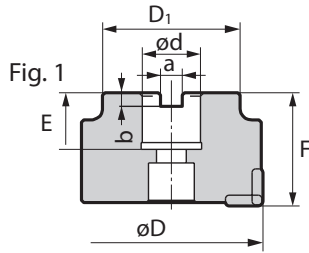

GOALMILL Cutter Bodies												Effective Cutting Dia.
Catalog Number	Stock	Dimensions (inch)							# of Teeth		Fig.	
		øD	øD ₁	ød	a	b	E	F	Roughing	Wiper		
GFV53000R	●	3.000	2.900	1.000	0.375	0.220	1.060	2.000	6	2	1	2.352
GFV54000R	●	4.000	3.380	1.500	0.625	0.385	1.060	2.000	10	2	1	3.342
GFV56000R	●	6.000	4.880	2.000	0.761	0.438	1.000	2.500	12	4	2	5.342
GFV58000R	●	8.000	6.040	2.500	1.00	0.560	1.595	2.500	20	4	3	7.342

NOTE: Left-handed cutters are made to order

GOALMILL Inserts & Hardware							
Catalog Number	Stock	Dimensions (inch)				Insert Screw*	Insert Wrench
		L	W	T	R		
LNGX160516PNFN-W-K244L9	●	0.625	0.375	0.187	0.063	BFTX03588	TTX15W
LNGX160516PNFN-W-K246L9	●						
LNGX160516PNFN-W-SN2100K	●						

*Torque specifications for insert screw= 26.5 in/lbs.

Cartridge & Hardware				
Wiper Cartridge*	Cartridge Mount Screw	Wrench for Cartridge Mount Screw	Axial Adjustment Screw	Wrench for Adjustment Screw
GFVK5R	BX0418	LT15	ED090225E	TTX15W

*Insert not included with cartridge

Micro Adjustment:

- Check each of the fixed pocket milling inserts to find the one at the highest setting.
- Load the wiper cartridges into the face mill body and torque the cartridge mount screw
- Adjust the wiper cartridge using the axial adjustment screw so that it is .0010" ~ .0012" above the highest fixed pocket milling insert



Recommended Running Conditions

Gray Cast Iron			
Grade	SFM	D.O.C.	IPT
K244L9	450~1150	0.004~0.030	0.004~0.015
K246L9	400~650		
SN2100K	1000~3000	0.010~0.080	0.004~0.010

Ductile Cast Iron			
Grade	SFM	D.O.C.	IPT
K244L9	450~800	0.004~0.030	0.004~0.015
K246L9	400~600		

*Greater depths of cut (up to 4mm) possible if wiper cartridges are removed.

NOTE: If the wiper inserts will be indexed without presetting the wiper cartridge heights again, the first preset height should be from 0.001" to 0.002" (0.025 to 0.050 mm) above the highest fixed pocket periphery insert.



Features & Benefits

- For iron and steel applications
- Combination of cutter body type and insert design allows for a wider application range
- Low cutting forces and V-shaped insert edge together provide stable machining and less vibration
- Significant cost savings due to 8 cutting edges; able to achieve 1.5 times higher efficiency than the leading competitor

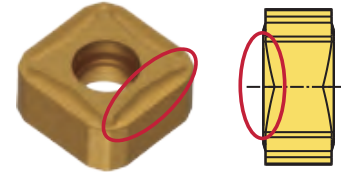

V-shaped cutting edge



Insert Characteristics

Indexable Milling

Shoulder Milling

Face Milling

High Feed Milling

Multi-purpose

Modular Tooling

UFO & SumiMill

Discontinued

Breaker type	Cross section	Application
<p>G-Type: for general purpose milling</p>		<p>G-Type</p> <p>low rigidity</p>
<p>H-Type: for heavy milling</p>		<p>H-Type</p> <p>plane</p> <p>heavy milling</p>

<p>SH-type with straight cutting edge</p> <p>straight</p>	<p>SH-Type</p>	<p>G-Type</p>
<p>comparison of combined force</p> <p>11% Decrease</p> <p>combined force (N)</p> <p>Cutting conditions: vc=600SFM fz=0.008 IPT Width=3.300" D.O.C.=0.118-0.236" dry Work material: Gray Cast Iron Tool: DNX12100R+G,SH</p>		



Rake Angle	Radial	-6°
	Axial	-5°

Max. Depth of Cut

P	M	K	N	S	H
Steel	Stainless Steel	Cast Iron	Non-ferrous	Aluminum	Exotic Alloy

SumiMill DNX Series

Applicable Insert: SNMT

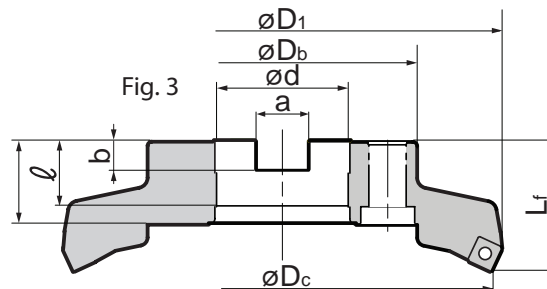
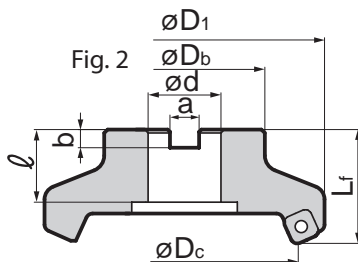
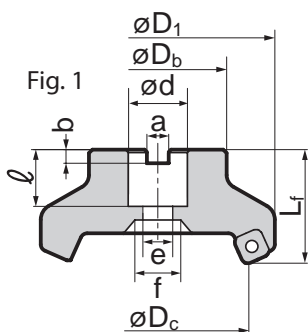

SumiMill DNX Bodies - Coarse Pitch														
Sumitomo Cat. Number	Dimensions (in)										# of Teeth	Pitch	Max D.O.C.	Fig.
	øD _c	øD ₁	øD _b	L _f	ød	a	b	l	e	f				
DNX43000R	3.000	3.303	2.250	1.750	1.000	0.375	0.220	1.020	0.531	0.797	6	Coarse	0.314"	1
DNX44000R	4.000	4.315	2.870	2.000	1.250	0.500	0.280	1.020	0.656	1.000	7			1
DNX44000R-1.50	4.000	4.303	3.750	2.500	1.500	0.625	0.380	1.000	0.780	1.180	7			4
DNX45000R	5.000	5.303	3.750	2.500	1.500	0.625	0.380	1.060	-	-	8			2
DNX46000R	6.000	6.303	4.380	2.500	1.500	0.625	0.380	1.060	-	-	10			2
DNX48000R	8.000	8.303	5.120	2.500	2.500	1.000	0.560	1.595	-	-	12			3

SumiMill DNX Bodies - Fine Pitch														
Sumitomo Cat. Number	Dimensions (in)										# of Teeth	Pitch	Max D.O.C.	Fig.
	øD _c	øD ₁	øD _b	L _f	ød	a	b	l	e	f				
DNXF43000R	3.000	3.303	2.250	1.750	1.000	0.375	0.220	1.020	0.531	0.797	8	Fine	0.314"	1
DNXF44000R	4.000	4.315	2.870	2.000	1.250	0.500	0.280	1.020	0.656	1.000	10			1
DNXF44000R-1.50	4.000	4.303	3.750	2.500	1.500	0.625	0.380	1.000	0.780	1.180	10			4
DNXF45000R	5.000	5.303	3.750	2.500	1.500	0.625	0.380	1.060	-	-	11			2
DNXF46000R	6.000	6.303	4.380	2.500	1.500	0.625	0.380	1.060	-	-	12			2
DNXF48000R	8.000	8.303	5.120	2.500	2.500	1.000	0.560	1.595	-	-	14			3

Inserts for DNX Series						
Sumitomo Cat. Number	ACK100	ACK200	ACK300	ACP200	Edge Type	Fig.
SNMT1205ZHEN-G	●	●	●	●	V shaped	4
SNMT1205ZHEN-H	●	●	●	●		5
SNMT1205ZHEN-SH	★	★	★	★	Straight edge	6

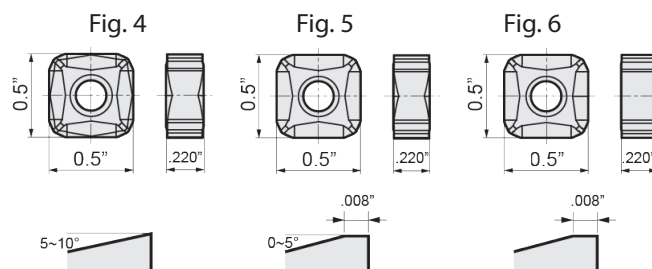

Recommended Running Conditions

Grade	Cast Iron				Steel	
	Gray Cast Iron		Ductile Cast Iron		Carbon Steel	Alloy Steel
	ACK200	ACK300	ACK100	ACK200	ACP200	ACP200
SFM	400 ~ 1100	400 ~ 950	350 ~ 950	350 ~ 850	350 ~ 875	350 ~ 950
IPT	.004 ~ .014	.004 ~ .014	.004 ~ .012	.004 ~ .012	.004 ~ .010	.004 ~ .010
Max. D.O.C.	~ 0.314	~ 0.314	~ 0.314	~ 0.314	~ 0.314	~ 0.314

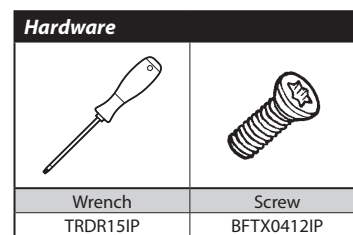

SUMIMILL SPIDER MILL

Applicable Insert: SNEX, SNMX

High Productivity Cast Iron Milling Cutter With Eight Cutting Edges



Features & Benefits

- Double negative milling cutter with positive cutting insert geometry
- High productivity shell mill for gray cast iron and ductile iron face milling
- Eight (8) cutting edges per insert
- Available in the new grades ACK100 and ACK200
- Unique positive chipbreaker insert provides less cutting force, more productivity and longer tool life

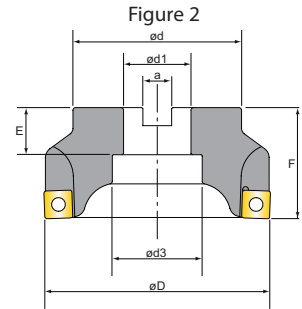
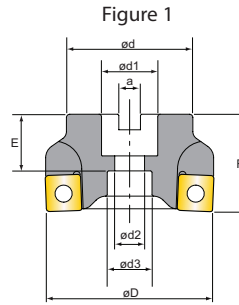
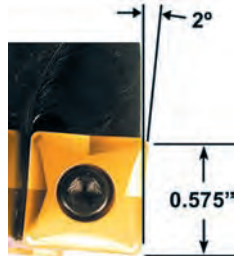

Spider Mill Cutter Bodies

Sumitomo Cat. No.	Status	Dimensions (Inch)										
		øD	ød	F	ød1	ød2	ød3	E	a	I.C.	Pitch	Fig.
SDP42000R	•	2.000"	1.500"	1.750"	0.750"	0.406"	0.609"	1.020"	0.312"	0.500"	4	1
SDP42500R	•	2.500"	1.750"	1.750"	1.000"	0.531"	0.797"	1.020"	0.375"	0.500"	5	1
SDP43000R	•	3.000"	2.250"	1.750"	1.000"	0.531"	0.797"	1.020"	0.375"	0.500"	6	1
SDP53000R	•	3.000"	2.250"	1.750"	1.000"	0.531"	0.797"	1.020"	0.385"	0.625"	5	1
SDP54000R	•	4.000"	2.756"	2.000"	1.250"	0.656"	1.030"	1.090"	0.515"	0.625"	7	1
SDP55000R	•	5.000"	3.750"	2.500"	1.500"	N/A	2.000"	1.060"	0.635"	0.625"	8	2
SDP56000R	•	6.000"	4.380"	2.500"	1.500"	N/A	2.000"	1.060"	0.635"	0.625"	10	2

• USA stocked item

Inserts

Sumitomo Cat. No.	ACK100	ACK200	CVD Coated				Dimensions (Inches)		
			I.C.	T	R	I.C.	T	R	
SNMX120412DP	•	•					0.500	0.1875	0.031
SNEX156612DP	•	•					0.625	0.2660	0.047

• USA stocked item

Hardware

Applicable Cutter	Insert Screw	Wrench
SDP4□000R	BFTX0412N	TRD15
SDP5□000R	BFTX0513N	TTX20

Torque specifications for BFTX0513N is 45-49 in/lbs.

See pages 613-615
for recommended
running parameters



HIGH FEED MILLING

Pages 373-377



INDEXABLE MILLING CUTTERS

PAGES

MSX Series	374-376
MS Series.....	377

Indexable
Milling

Shoulder
Milling

Face
Milling

High
Feed
Milling

Multi-
purpose

Modular
Tooling

UFO &
SumiMill

Discon-
tinued

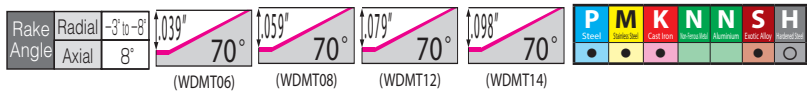

General Features

The Metal Slash Mill MSX Type is a multi-purpose cutter capable of roughing at ultra-high feeds. Its wide application range dramatically boosts efficiency. Inserts are available in four sizes to cover a wide variety of milling needs

Up to 0.055 IPT feed rates!

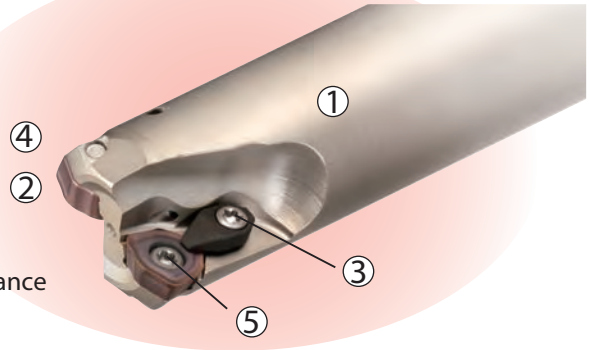

Characteristics

- Highly Durable Body** Special surface treatment improves scratch resistance
- Versatile Machining Operations** Use for ramping, helical, and drilling work
- Double Lock** Extra-strong clamping ensures stable cutting performance (Single clamp for ø22mm or smaller diameters)
- With oil hole** Improved chip evacuation with air or coolant supply hole and specially shaped pocket design
- Insert Shape** Unique tool shape packs cutting performance and cutting edge strength

Corner Finishing

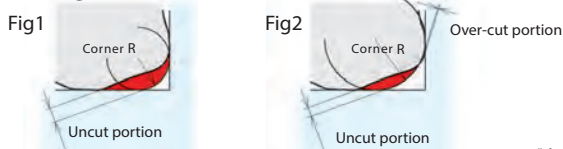

* Actual machined corners will have uncut and over-cut portions due to the shape of the inserts.

Corner R	WDMT06 Type			WDMT08 Type			WDMT12 Type			WDMT14 Type		
	Uncut portion	Over-cut portion	Fig	Uncut portion	Over-cut portion	Fig	Uncut portion	Over-cut portion	Fig	Uncut portion	Over-cut portion	Fig
.079	0.016	0	1	0.029	0	1	0.052	0	1	0.065	0	1
.098	0.010	0.003	2	0.023	0	1	0.046	0	1	0.059	0	1
.118				0.018	0.001	2	0.041	0	1	0.054	0	1
.138							0.035	0.00004	2	0.048	0	1
.157										0.042	0.00063	2

Ramping & Helical Milling

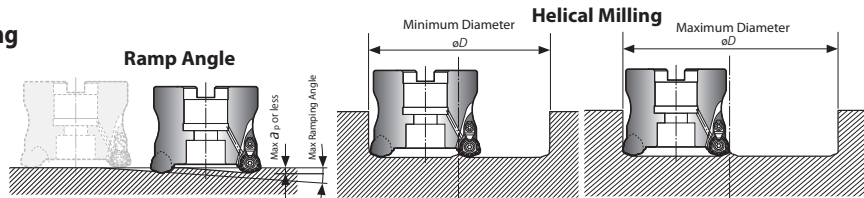

Center uncut portion can't be removed with same cutter

øD _c	WDMT06 Type			WDMT08 Type			WDMT12 Type			WDMT14 Type		
	Ramping Max. Ramping Angle	Helical Milling Min.	Helical Milling Max.	Ramping Max. Ramping Angle	Helical Milling Min.	Helical Milling Max.	Ramping Max. Ramping Angle	Helical Milling Min.	Helical Milling Max.	Ramping Max. Ramping Angle	Helical Milling Min.	Helical Milling Max.
16	6° 00'	0.827	1.181									
17	5° 00'	0.905	1.259									
18	4° 30'	1	1.339									
20	3° 30'	1.142	1.496	7° 30'	1	1.496						
22	3° 00'	1.299	1.654	5° 30'	1.142	1.654						
25	2° 00'	1.535	1.889	4° 00'	1.378	1.889						
28				3° 00'	1.614	2.126						
32				2° 30'	1.929	2.441	6° 30'	1.654	2.441			
35				2° 00'	2.165	2.677	5° 00'	1.889	2.677			
40				2° 00'	2.559	3.071	4° 00'	2.284	3.071	6° 00'	2.087	3.071
50							2° 30'	3.071	3.858	3° 30'	2.874	3.858
63							2° 00'	4.055	4.882	2° 00'	3.898	4.882
80										1° 30'	5.236	6.221
100										1° 00'	6.811	7.795
0.750	4° 00'	1.11	1.417									
1.000	2° 00'	1.58	1.92	4° 00'	1.42	1.92						
1.250				2° 30'	1.93	2.4	6° 30'	1.62	2.4			
1.500				1° 30'	2.45	2.91	4° 00'	2.13	2.91			
2.000				1° 00'	3.39	3.91	2° 30'	3.08	3.91	3° 30'	2.90	3.91
2.500							1° 30'	4.08	4.91	2° 30'	3.90	4.91
3.000							1° 00'	5.08	5.91	1° 30'	4.90	5.91
4.000							0° 30'	7.08	7.91	1° 00'	6.90	7.91
5.000										0° 30'	8.90	9.91
6.000										0° 30'	10.90	11.91



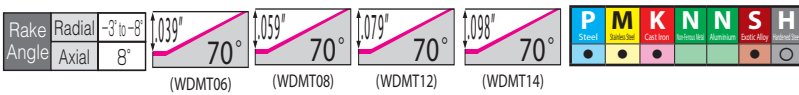

SumiMill -Inch
MSX SERIES
 Applicable Insert: WDMT

MSX Endmills - Inch

Catalog Number	ϕD_c	ϕD_s	L	L_f	l_s	Teeth	Insert Type
MSX20750EW	0.750	0.750	5.125	2.000	2.031	3	WDMT06
MSX20750ELC	0.750	0.750	8.000	2.000	6.000	3	
MSX31000EW	1.000	1.000	4.781	2.500	2.281	2	WDMT08
MSX31000ELC	1.000	1.000	10.000	2.500	7.500	2	
MSXF31000EW	1.000	1.000	4.781	2.500	2.281	3	
MSXF31250EW	1.250	1.250	4.781	2.500	2.281	3	
MSXF31500EW	1.500	1.500	4.781	2.500	2.281	4	WDMT12
MSX41250EW	1.250	1.250	4.781	2.500	2.281	2	
MSX41250ELC	1.250	1.250	10.000	2.500	7.500	2	
MSX41500EW	1.500	1.250	4.781	2.500	2.281	2	
MSX41500ELC	1.500	1.500	10.000	2.500	7.500	2	
MSXF41500EW	1.500	1.500	4.781	2.500	2.281	3	

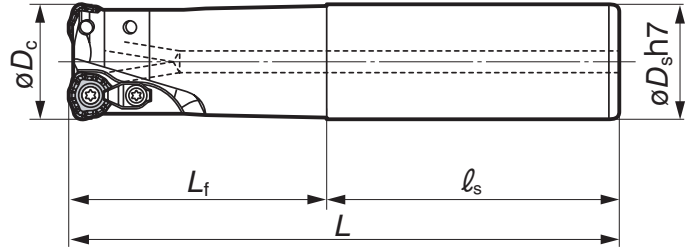

MSX Shell Mill - INCH

Catalog Number	Stock	Dimensions (in)								No. of Teeth	Insert	
		ϕD_c	ϕD_1	L_f	ϕd	a	b	l_1	ϕd_1			ϕd_2
MSX31500R	●	1.500	1.339	1.530	0.750	0.312	0.190	0.750	0.609	0.406	4	WDMT08
MSX32000R	●	2.000	1.850	2.000	0.750	0.312	0.190	0.750	0.609	0.406	5	
MSX42000R	●	2.000	1.850	2.000	0.750	0.312	0.190	0.750	0.609	0.406	4	WDMT12
MSX42500R	●	2.500	2.362	2.000	1.000	0.375	0.220	0.750	0.797	0.530	5	
MSX43000R	●	3.000	2.756	2.000	1.000	0.375	0.220	0.750	0.797	0.530	6	
MSX44000R-1.25	●	4.000	3.740	2.500	1.250	0.500	0.280	0.750	1.000	0.656	7	
MSX44000R-1.50	●	4.000	3.740	2.500	1.500	0.625	0.380	1.000	2.000	0.781	7	
MSXM42000R	●	2.000	1.850	2.000	0.750	0.312	0.190	0.750	0.609	0.406	5	
MSX52000R	●	2.000	1.850	2.000	0.750	0.312	0.190	0.750	0.609	0.406	4	WDMT14
MSX52500R	●	2.500	2.362	2.000	1.000	0.375	0.220	0.750	0.797	0.531	5	
MSX53000R	●	3.000	2.756	2.000	1.000	0.375	0.220	0.750	0.797	0.531	5	
MSX54000R-1.25	●	4.000	3.740	2.500	1.250	0.500	0.280	0.750	1.000	0.656	6	
MSX54000R-1.50	●	4.000	3.740	2.500	1.500	0.625	0.380	1.000	2.000	0.781	6	
MSX55000R	●	5.000	3.937	2.500	1.500	0.625	0.380	1.000	2.000	0.781	7	
MSX56000R	●	6.000	3.937	2.500	1.500	0.625	0.380	1.000	2.000	0.781	8	

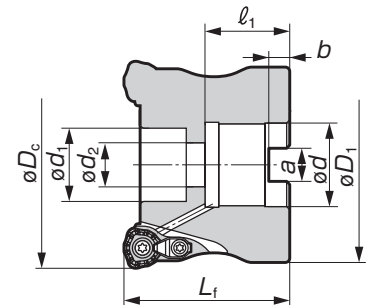

Type	Insert	Insert						Insert Dimensions (in)			Max Depth of Cut (In.)				
		P	K	M	S	ACP200	ACP300	ACK200	ACK300	ACM200		ACM300	W	R	t
General Purpose	WDMT0603ZDTR	●	●	●	●	●	●	●	●	●	●	.250	.0591	.1181	.039
	WDMT0804ZDTR	●	●	●	●	●	●	●	●	●	●	.335	.0787	.1575	.059
	WDMT1205ZDTR	●	●	●	●	●	●	●	●	●	●	.472	.0787	.1969	.079
	WDMT1406ZDTR	●	●	●	●	●	●	●	●	●	●	.551	.0787	.2362	.098
Strong Edge	WDMT0603ZDTR-H	●	●	●	●	●	●	●	●	●	●	.250	.0591	.1181	.039
	WDMT0804ZDTR-H	●	●	●	●	●	●	●	●	●	●	.335	.0787	.1575	.059
	WDMT1205ZDTR-H	●	●	●	●	●	●	●	●	●	●	.472	.0787	.1969	.079
	WDMT1406ZDTR-H	●	●	●	●	●	●	●	●	●	●	.551	.0787	.2362	.098

General Purpose Edge	H : Strong Edge
General (First choice)	Interrupted Cutting
 Sharper Edge	 Emphasis on Fracture Resistance

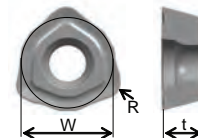

Hardware					
Screw	Wrench	Clamp	Ring	Clamp Screw	Applicable Cutter
BFTX02505IP	TRDR08IP	-	-	-	MSX20000
BFTX0305IP	TRDR08IP	CCH3.5	CR3	BFTX03510IP08	MSX30000 ≤1.0"
BFTX0306IP	TRDR08IP	CCH3.5	CR3	BFTX03510IP08	MSX30000 >1.0"
BFTX0409IP	TRDR15IP	CCH3.5	CR3	BFTX03510IP15	MSX40000
BFTX0511IP	TRDR20IP	CCH4.5	CR3	BFTX04513IP20	MSX50000



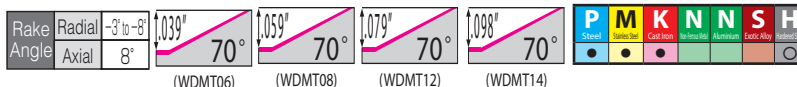

MSX End Mill - Metric

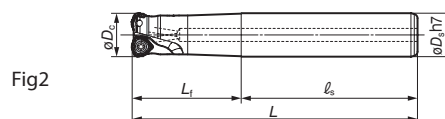
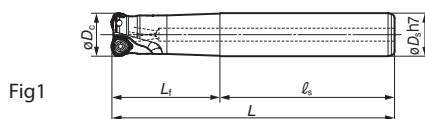

Body Insert: WDMT06 Type

Cat. No.	Stock	Dimensions (mm)					No. of Teeth	Weight (kg)	Fig
		øD _c	øD _s	L _f	l _s	L			
MSX 06016ES	★	16	16	30	80	110	2	0.2	1
MSX 06016EM	★	16	16	70	80	150	2	0.2	1
MSX 06017EM	★	17	16	20	130	150	2	0.2	1
MSX 06018EM	★	18	16	20	130	150	2	0.2	1
MSX 06020ES	★	20	20	50	80	130	3	0.3	1
MSX 06020EM	★	20	20	100	80	180	3	0.4	1
MSX 06022EM	★	22	20	30	150	180	3	0.4	1
MSX 06025ES	★	25	25	60	80	140	3	0.5	1
MSX 06025EM	★	25	25	120	130	250	3	0.8	1

Body Insert: WDMT12 Type

Cat. No.	Stock	Dimensions (mm)					No. of Teeth	Weight (kg)	Fig
		øD _c	øD _s	L _f	l _s	L			
MSX 12032ES	★	32	32	70	80	150	2	0.8	2
MSX 12032EM	★	32	32	120	130	250	2	1.4	2
MSX 12035EM	★	35	32	50	200	250	2	1.4	2
MSX 12040ES	★	40	32	50	100	150	3	0.9	2
MSX 12040EM	★	40	32	50	200	250	3	1.5	2
MSX 12050EM	★	50	42	50	200	250	4	2.6	2

Body Insert: WDMT08 Type

Cat. No.	Stock	Dimensions (mm)					No. of Teeth	Weight (kg)	Fig
		øD _c	øD _s	L _f	l _s	L			
MSX 08020ES	★	20	20	50	80	130	2	0.3	1
MSX 08020EM	★	20	20	100	80	180	2	0.3	1
MSX 08022EM	★	22	20	30	150	180	2	0.4	1
MSX 08025ES	★	25	25	60	80	140	2	0.4	2
MSX 08025EM	★	25	25	120	130	250	2	0.8	2
MSX 08028EM	★	28	25	40	210	250	2	0.9	2
MSX 08032ES	★	32	32	70	80	150	3	0.8	2
MSX08032EM	★	32	32	120	130	250	3	1.4	2
MSX 08035EM	★	35	32	50	200	250	3	1.5	2

Body Insert: WDMT14 Type

Cat. No.	Stock	Dimensions (mm)					No. of Teeth	Weight (kg)	Fig
		øD _c	øD _s	L _f	l _s	L			
MSX 14040ES	★	40	32	50	100	150	2	0.9	2
MSX 14040EM	★	40	32	50	200	250	2	1.5	2
MSX 14050ES	★	50	42	50	100	150	3	1.5	2
MSX 14050EM	★	50	42	50	200	250	3	2.5	2
MSX 14063ES	★	63	42	50	100	150	4	1.7	2
MSX 14063EM	★	63	42	50	200	250	4	2.8	2

Inserts are not included.

MSX Shell Mill - Metric

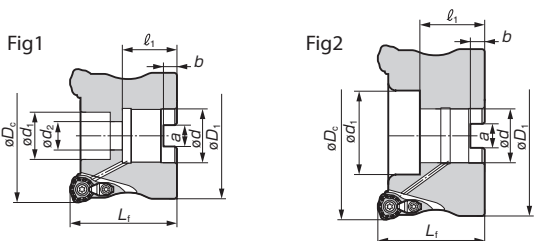

Catalog Number	Stock	Dimensions (mm)									No. of Teeth	Weight (kg)	Fig.	Insert
		øD _c	øD ₁	L _f	ød	a	b	l ₁	ød ₁	ød ₂				
MSX08040RS	★	40	37	45	16	8.4	5.6	18	13.5	9	4	0.2	1	WDMT08
MSX12050RS	★	50	47	50	22	10.4	6.3	20	18	11	4	0.3	1	WDMT12
MSX12063RS	★	63	60	50	22	10.4	6.3	20	18	11	5	0.6	1	WDMT12
MSX14050RS	★	50	47	50	22	10.4	6.3	20	17	11	3	0.3	1	WDMT14
MSX14063RS	★	63	60	50	22	10.4	6.3	20	18	11	4	0.6	1	WDMT14
MSX14080RS	★	80	76	63	27	12.4	7.0	25	20	13.5	5	1.4	1	WDMT14
MSX14100RS	★	100	96	63	32	14.4	8.5	32	44	-	6	2.2	2	WDMT14
MSX14080R	★	80	76	63	31.75	12.7	8.0	32	28	17	5	1.3	1	WDMT14
MSX14100R	★	100	96	63	31.75	12.7	8.0	32	28	17	6	2.4	1	WDMT14

(a_p: Depth of Cut f_z: Feed Rate)

Work Material	Grade	Cutting Speed v _c (SFM)	Insert Type	Endmill Type								Shell Type					
				ø16		ø20		ø25		ø32		ø40		ø50/ø63		ø80/ø100	
				a _p (in.)	f _z (in./t)	a _p (in.)	f _z (in./t)	a _p (in.)	f _z (in./t)	a _p (in.)	f _z (in./t)	a _p (in.)	f _z (in./t)	a _p (in.)	f _z (in./t)	a _p (in.)	f _z (in./t)
General Steel Below 200HB	ACP200	330-500-650	WDMT 06	0.032	0.032	0.032	0.032	-	-	-	-	-	-	-	-	-	
			WDMT 08	-	-	0.039	0.039	0.039	0.047	0.039	0.047	-	-	-	-	-	
			WDMT 12	-	-	-	-	-	0.047	0.055	0.047	0.055	0.047	0.055	-	-	
			WDMT 14	-	-	-	-	-	-	-	0.059	0.059	0.059	0.059	0.059	0.059	
Alloy Steel Below 45HRC	ACP200	260-430-590	WDMT 06	0.028	0.032	0.028	0.032	-	-	-	-	-	-	-	-		
			WDMT 08	-	-	0.032	0.039	0.032	0.047	0.032	0.047	-	-	-	-		
			WDMT 12	-	-	-	-	-	0.039	0.055	0.039	0.055	0.039	0.055	-		
			WDMT 14	-	-	-	-	-	-	-	0.051	0.059	0.051	0.059	0.051	0.059	
Stainless Steel SUS304, Others	ACP300	260-400-500	WDMT 06	0.032	0.028	0.032	0.028	-	-	-	-	-	-	-	-		
			WDMT 08	-	-	0.039	0.032	0.039	0.032	0.039	0.032	-	-	-	-		
			WDMT 12	-	-	-	-	-	0.047	0.047	0.047	0.047	0.047	0.047	-		
			WDMT 14	-	-	-	-	-	-	-	0.059	0.051	0.059	0.051	0.059	0.051	
Cast Iron FC,FCD	ACK200 ACK300	330-500-650	WDMT 06	0.032	0.039	0.032	0.039	-	-	-	-	-	-	-	-		
			WDMT 08	-	-	0.039	0.047	0.039	0.055	0.039	0.055	-	-	-	-		
			WDMT 12	-	-	-	-	-	0.047	0.059	0.047	0.059	0.047	0.059	-		
			WDMT 14	-	-	-	-	-	-	-	0.059	0.071	0.059	0.071	0.059	0.071	
Hardened Steel Below 50HRC	ACK200 ACK300	130-260-330	WDMT 06	0.020	0.020	0.020	0.020	-	-	-	-	-	-	-	-		
			WDMT 08	-	-	0.020	0.024	0.020	0.032	0.020	0.032	-	-	-	-		
			WDMT 12	-	-	-	-	-	0.024	0.039	0.024	0.039	0.024	0.039	-		
			WDMT 14	-	-	-	-	-	-	-	0.039	0.047	0.039	0.047	0.039	0.047	

The above recommended cutting conditions may require adjustment according to machine rigidity and work rigidity. The above figures are guidelines for use with the BT50 machine tool. The above cutting conditions assume a tool overhang length of L/D=3 (i.e. overhang length is 3 times tool diameter) or less.

When tool overhang is more than L/D=3 and less than or equal L/D=5, settings should be adjusted to approximately 70 to 80% of those indicated in the above cutting conditions (i.e. a_p and f_z).

When tool overhang is more than L/D=5 and less than or equal L/D=8, settings should be adjusted to approximately 50 to 60% of those indicated in the above cutting conditions (i.e. a_p and f_z).



Indexable Milling
Shoulder Milling
Face Milling
High Feed Milling
Multi-purpose
Modular Tooling
UFO & SumiMill
Discontinued

Features & Benefits

- Screw-on insert assembly
- U.S. stock standard bodies available in 2.000" - 4.000" diameters
Worldwide stock includes 63.0 mm - 125 mm
- High feed rates (Maximum feed rate = 0.078" IPT) result in high productivity milling
- Four corner insert design yields low tooling costs per part
- Unique design directs cutting forces into the machine spindle to facilitate high feed rates even in low rigidity conditions
- Insert grades available for carbon steel, stainless steel, cast iron, & die steel

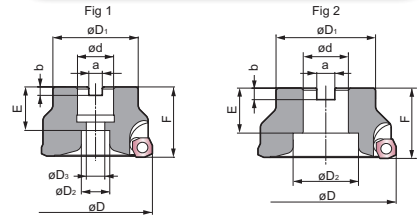

MS Mill Availability		Dimensions (Inch / mm)										No. of Teeth	Fig.
Sumitomo Cat. No.	Stock	D	D1	D2	D3	F	d	a	b	E			
MS14020SR	•	2.000	1.500	0.609	0.406	1.750	0.750	0.319	0.190	1.020	4	1	
MS14025SR	•	2.500	1.750	0.797	0.531	1.750	1.000	0.375	0.220	1.020	4	1	
MS14030R	•	3.000	2.250	0.797	0.531	1.750	1.000	0.375	0.220	1.020	5	1	
MS14040R	•	4.000	2.870	1.000	0.656	2.000	1.250	0.500	0.280	1.020	6	1	
MS14063RS	★	63.0	59.0	18.0	11.0	40.0	22.0	10.4	6.3	26.0	4	1	
MS14080R	★	80.0	60.0	20.0	13.0	50.0	25.4	9.5	6.0	31.0	5	1	
MS14100R	★	100.0	70.0	46.0	-	50.0	31.8	12.7	8.0	32.0	6	2	
MS14125R	★	125.0	80.0	56.0	-	63.0	38.1	15.9	10.0	38.0	7	2	

• USA stocked item ★ Worldwide Warehouse item

Programmed Radius Chart						
Fig. 1		Fig. 2		Over Cut		
Remains		Remains				
SDMW (SDEW)1406ZDTR						
R		Remains		Over Cut		Fig.
in	mm	in	mm	in	mm	
.079	2.0	0.064	1.628	0	0	1
.098	2.5	0.058	1.464	0	0	1
.118	3.0	0.051	1.300	0	0	1
.138	3.5	0.0455	1.136	0	0	1
.158	4.0	0.038	0.972	0.0005	0.014	2
.177	4.5	0.032	0.808	0.005	0.118	2
.197	5.0	0.025	0.644	0.010	0.258	2

Inserts							
Sumitomo Cat. No.	Coated		Dimensions (Inches)				Fig.
	CS3000	ACK200	I.C.	T	R2	R5	
SDEW1406ZDTR	★	★	0.551	0.236	0.079	0.197	4
SDMW1406ZDTR	•	•	0.551	0.236	0.079	0.197	3

SDEW = Ground tolerance inserts
• USA stocked item ★ Worldwide Warehouse item

Hardware		
Applicable Cutter	Insert Screw	Wrench
MS 1400 series	BFTX0513N	TTX20

Torque specifications for BFTX0513N is 45-55 in/lbs.

Recommended Running Conditions

Material	Cutting Speed (SFM)	Feed Rate (IPT)	Depth of Cut (Inch)	Recommended Grades
Carbon Steel	500 ~ 820	< 0.078	< 0.059	ACP200, ACP300
Die Steel	325 ~ 650	< 0.059	< 0.059	ACP200, ACP300
Stainless Steel	525 ~ 650	< 0.039	< 0.059	ACM300, ACM200
Cast Iron	325 ~ 650	< 0.059	< 0.078	ACK200, ACK300

Ramp Angle				
Cutting Edge dia.	SDMW (SDEW)1406ZDTR			
	Ramp Angle	Helical Milling		
		Min ϕD	Max ϕD	
2.0	2° 00'	3.189	3.858	
2.5	1° 30'	4.213	4.882	
3.0	1° 10'	5.197	5.866	
4.0	0° 49'	7.205	7.874	
63	1° 00'	106	123	
80	0° 50'	140	157	
100	0° 30'	180	197	
125	0° 30'	230	247	





SUMITOMO

CARBIDE - CBN - DIAMOND

1-800-950-5202

www.sumicarbide.com

MULTI-PURPOSE MILLING

Pages 379-392



INDEXABLE MILLING CUTTERS	PAGES
RSX Series.....	380-383
WRCX Series.....	384-385
WBMR Ballnose Endmills (Roughing Endmill)...	386-388
WBMF Ballnose Endmills (Finishing Endmill)...	389-390
WMM Endmills	391-392

Indexable
Milling

Shoulder
Milling

Face
Milling

High
Feed
Milling

Multi-
purpose

Modular
Tooling

UFO &
SumiMill

Discon-
tinued



Features & Benefits

- Wide application range that includes face milling, ramping, slotting, 3-D interpolation, and helical boring
- A highly durable body made of special alloyed steel and protected by a hard surface treatment
- Pocket design eliminates insert rotation during aggressive machining

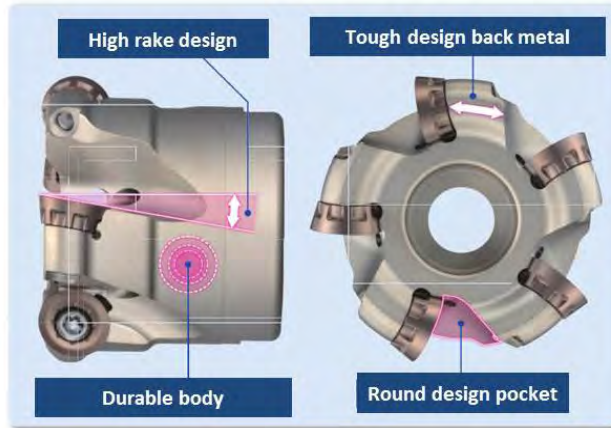

Low Cutting Force

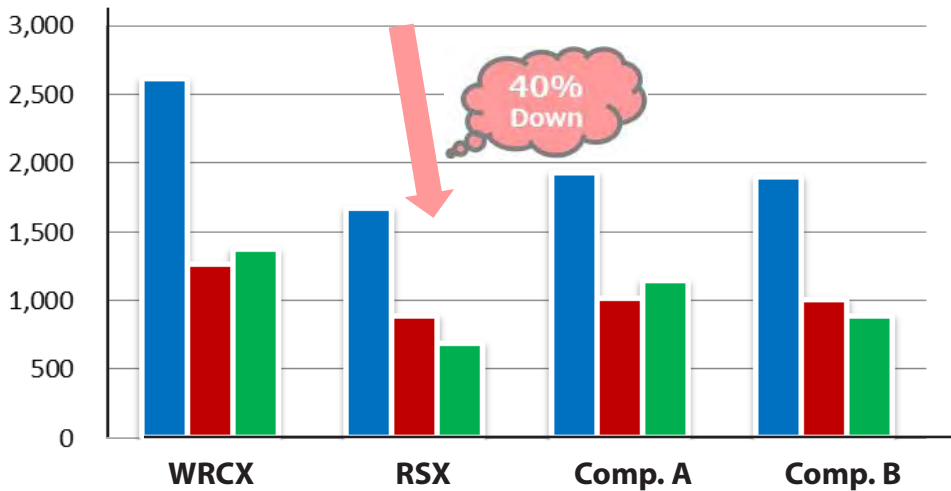

Work piece: 304 Stainless Steel
Cutter: RSXF1205ORS
 (2" cutter)
Cutting conditions:
 $V_c = 650$ SFM
 $f_z = 0.02$ in/t
 $a_p = 0.079$ in.
 $a_e = 0.39$ in., WET

Low Vibration

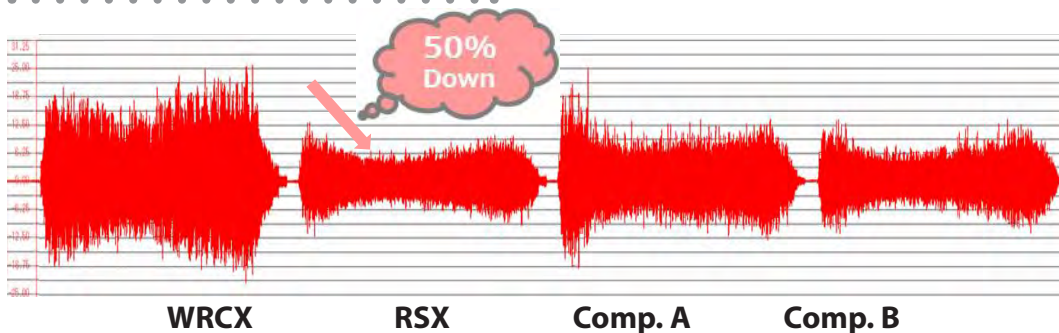

Work piece: 304 Stainless Steel
Cutter: RSXF1205ORS
 (2" cutter)
Cutting conditions:
 $V_c = 650$ SFM
 $f_z = 0.02$ in/t
 $a_p = 0.079$ in.
 $a_e = 0.39$ in., DRY

Indexable Milling
 Shoulder Milling
 Face Milling
 High Feed Milling
 Multi-purpose
 Modular Tooling
 UFO & SumiMill
 Discontinued



Rake Angle	Radial	-5°
	Axial	10°

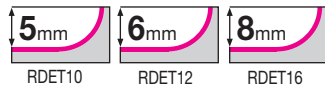

P	M	K	N	N	S	H
Steel	Stainless Steel	Cast Iron	Non-Ferrous Metals	Aluminum	Exotic Alloy	Hardened Steel

RSX Series

Fig. 1

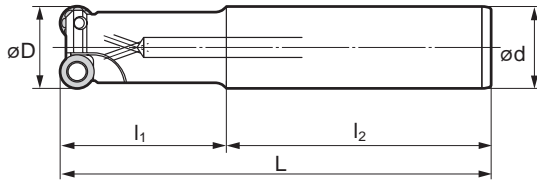

Fig. 2

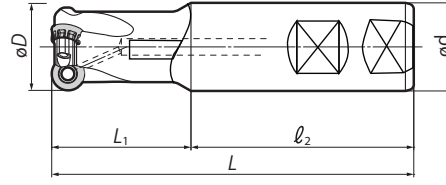
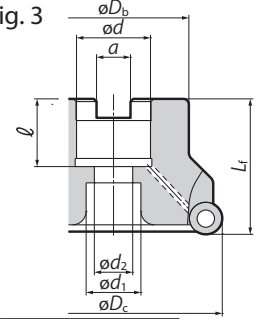

Fig. 3



RSX End Mill - INCH

Catalog No.	Stock	øD	ød	L	l ₁	l ₂	Insert Type	# of Inserts	Shank Style	Weight (lbs)	Max Ramp Angle	Fig.
RSX31000EW	•	1.000	1.000	4.340	2.060	2.280	RDET10	2	Weldon	0.95	10° 15'	2
RSX31250EW	•	1.250	1.250	4.340	2.060	2.280	RDET10	3	Weldon	1.15	6° 45'	2
RSX31500EW	•	1.500	1.250	4.340	2.060	2.280	RDET10	3	Weldon	1.25	4° 45'	2
RSX41250EW	•	1.250	1.250	4.340	2.060	2.280	RDET12	2	Weldon	1.20	12° 30'	2
RSX41500EW	•	1.500	1.250	4.340	2.060	2.280	RDET12	3	Weldon	1.50	8° 30'	2
RSXF31000EW	•	1.000	1.000	4.340	2.060	2.280	RDET10	3	Weldon	1.00	10° 15'	2
RSXF31000ELC	•	1.000	1.000	10.000	3.750	6.250	RDET10	3	Cylindrical	2.00	10° 15'	1
RSXF31250EW	•	1.250	1.250	4.340	2.060	2.280	RDET10	4	Weldon	1.25	6° 45'	2
RSXF31250ELC	•	1.250	1.250	10.000	3.750	6.250	RDET10	4	Cylindrical	2.75	6° 45'	1
RSXF31500EW	•	1.500	1.250	4.340	2.060	2.280	RDET10	4	Weldon	1.40	4° 45'	2
RSXF31500ELC	•	1.500	1.250	10.000	3.750	6.250	RDET10	4	Cylindrical	3.25	4° 45'	1
RSXF41250EW	•	1.250	1.250	4.340	2.060	2.280	RDET12	3	Weldon	1.40	12° 30'	2
RSXF41250ELC	•	1.250	1.250	10.000	3.750	6.250	RDET12	3	Cylindrical	3.50	12° 30'	1
RSXF41500EW	•	1.500	1.250	4.340	2.060	2.280	RDET12	4	Weldon	1.65	8° 30'	2
RSXF41500ELC	•	1.500	1.250	10.000	3.750	6.250	RDET12	4	Cylindrical	4.00	8° 30'	1

RSX Shell Mill - INCH

Catalog N	Stock	øD _c	øD _b	L _f	ød	ød ₂	ød ₁	ℓ	a	Insert Type	# of Inserts	Weight (lbs)	Max Ramp Angle	Fig.
RSX32000R	•	2.000	1.500	1.750	0.750	0.406	0.609	0.750	0.312	RDET10	4	0.80	3° 15'	3
RSX42000R	•	2.000	1.500	1.750	0.750	0.406	0.609	0.750	0.312	RDET12	4	0.70	5° 30'	3
RSX42500R	•	2.500	1.750	1.750	1.000	0.531	0.797	0.750	0.375	RDET12	5	1.1	4°	3
RSX43000R	•	3.000	2.250	1.750	1.000	0.531	0.797	0.750	0.375	RDET12	6	1.75	3°	3
RSX44000R-1.25	•	4.000	2.870	2.000	1.250	0.656	1.000	0.750	0.500	RDET12	7	3.75	2°	3
RSX44000R-1.50	•	4.000	2.870	2.500	1.500	0.781	2.000	1.000	0.625	RDET12	7	4.00	2°	3
RSX45000R	•	5.000	3.750	2.500	1.500	0.781	2.000	1.000	0.625	RDET12	8	7.60	1° 30'	3
RSX46000R	•	6.000	4.380	2.500	1.500	0.781	2.000	1.000	0.625	RDET12	9	11.90	1°	3
RSX52500R	•	2.500	1.750	1.750	1.000	0.531	0.797	0.750	0.375	RDET16	4	0.95	5° 50'	3
RSX53000R	•	3.000	2.250	1.750	1.000	0.531	0.797	0.750	0.375	RDET16	5	1.50	4° 20'	3
RSX54000R-1.25	•	4.000	2.870	2.000	1.250	0.656	1.000	0.750	0.500	RDET16	7	4.25	2° 50'	3
RSX54000R-1.50	•	4.000	2.870	2.500	1.500	0.781	2.000	1.000	0.625	RDET16	7	4.90	2°	3
RSX55000R	•	5.000	3.750	2.500	1.500	0.781	2.000	1.000	0.625	RDET16	8	7.1	1° 30'	3
RSX56000R	•	6.000	4.380	2.500	1.500	0.781	2.000	1.000	0.625	RDET16	9	11.2	1°	3
RSXF32000R	•	2.000	1.500	1.750	0.750	0.406	0.609	0.750	0.312	RDET10	6	0.75	3° 15'	3
RSXF42000R	•	2.000	1.500	1.750	0.750	0.406	0.609	0.750	0.312	RDET12	5	0.65	5° 30'	3
RSXF42500R	•	2.500	1.750	1.750	1.000	0.531	0.797	0.750	0.375	RDET12	6	1.05	4°	3
RSXF43000R	•	3.000	2.250	1.750	1.000	0.531	0.797	0.750	0.375	RDET12	8	1.75	3°	3
RSXF44000R-1.25	•	4.000	2.870	2.000	1.250	0.656	1.000	0.750	0.500	RDET12	9	4.75	2°	3
RSXF44000R-1.50	•	4.000	2.870	2.500	1.500	0.781	2.000	1.000	0.625	RDET12	9	5.25	2°	3
RSXF45000R	•	5.000	3.750	2.500	1.500	0.781	2.000	1.000	0.625	RDET12	11	7.5	1° 30'	3
RSXF46000R	•	6.000	4.380	2.500	1.500	0.781	2.000	1.000	0.625	RDET12	12	11.75	1°	3
RSXF52500R	•	2.500	1.750	1.750	1.000	0.531	0.797	0.750	0.375	RDET16	5	0.85	5° 50'	3
RSXF53000R	•	3.000	2.250	1.750	1.000	0.531	0.797	0.750	0.375	RDET16	6	1.55	4° 20'	3
RSXF54000R-1.25	•	4.000	2.870	2.000	1.250	0.656	1.000	0.750	0.500	RDET16	8	3.25	2° 50'	3
RSXF54000R-1.50	•	4.000	2.870	2.500	1.500	0.781	2.000	1.000	0.625	RDET16	8	4.35	2°	3
RSXF55000R	•	5.000	3.750	2.500	1.500	0.781	2.000	1.000	0.625	RDET16	9	6.4	1° 30'	3
RSXF56000R	•	6.000	4.380	2.500	1.500	0.781	2.000	1.312	0.625	RDET16	10	10.5	1°	3



RSX Series

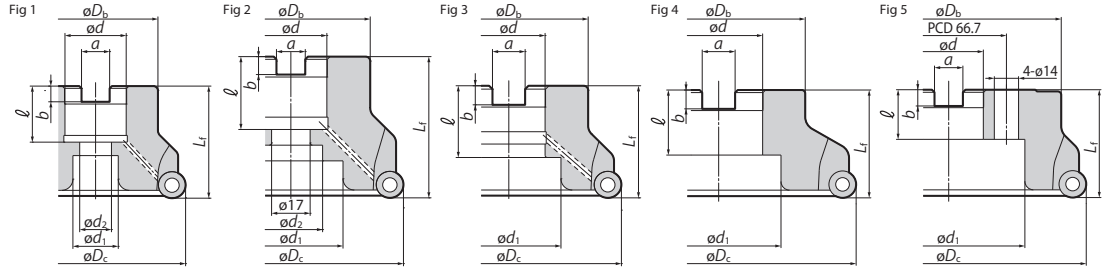
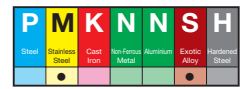
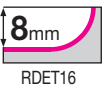

RSX Shell Mill - Metric

Catalog No.	Stock	ϕD_c	ϕD_b	L_f	ϕd	a	b	ℓ	ϕd_1	ϕd_2	Insert Type	# of Inserts	Weight (lbs)	Max. Ramp Angle	Fig.
RSX10040RS	★	40	34	40	16	8.4	5.6	18	14	9	RDE10	4	0.45	4° 30'	1
RSX10050RS	★	50	40	40	22	10.4	6.3	20	18	11	RDE10	5	0.66	3° 15'	1
RSX10052RS	★	52	40	40	22	10.4	6.3	20	18	11	RDE10	5	0.89	3° 10'	1
RSX12040RS	★	40	32	40	16	8.4	5.6	18	13.5	9	RDE12	3	0.45	8° 00'	1
RSX12050RS	★	50	40	40	22	10.4	6.3	20	18	11	RDE12	4	0.66	5° 30'	1
RSX12052RS	★	52	40	40	22	10.4	6.3	20	18	11	RDE12	4	0.66	5° 15'	1
RSX12063RS	★	63	40	40	22	10.4	6.3	20	18	11	RDE12	5	0.89	4° 00'	1
RSX12066RS	★	66	55	50	27	12.4	7.0	25	20	14	RDE12	6	1.54	3° 45'	1
RSX12080RS	★	80	55	50	27	12.4	7.0	25	20	14	RDE12	6	2.20	2° 50'	1
RSX12100RS	★	100	70	50	32	14.4	8.5	32	46	-	RDE12	6	3.09	2° 10'	3
RSX16063RS	★	63	50	40	22	10.4	6.3	20	18	11	RDE16	4	1.10	6° 00'	1
RSX16080RS	★	80	55	50	27	12.4	7.0	25	20	14	RDE16	5	1.98	4° 10'	1
RSX16100RS	★	100	70	50	32	14.4	8.532	32	46	-	RDE16	6	2.87	3° 00'	3
RSX16125RS	★	125	80	63	40	16.4	9.5	29	52	29	RDE16	6	5.73	2° 20'	1

RSX Shell Mill - Metric (with Inch Arbor)

RSX12080R	★	80	55	50	1.0 in.	9.5	6.0	25	20	13	RDE12	6	2.20	2° 50'	1
RSX12100R	★	100	70	63	1.25 in.	12.7	8.0	32.5	46	28	RDE12	6	4.19	2° 10'	2
RSX16080R	★	80	55	50	1.0 in.	9.5	6.0	25	20	13	RDE16	5	1.98	4° 10'	1
RSX16100R	★	100	70	63	1.25 in.	12.7	8.0	32.5	46	28	RDE16	6	3.97	3° 00'	2
RSX16125R	★	125	80	63	1.50 in.	15.9	10.0	35.5	55	30	RDE16	6	5.95	2° 20'	1

RSX Shell Mill - Metric

RSXF10040RS	★	40	34	40	16	8.4	5.6	18	14	9	RDE10	5	0.45	4° 30'	1
RSXF10050RS	★	50	40	40	22	10.4	6.3	20	18	11	RDE10	6	0.66	3° 15'	1
RSXF10052RS	★	52	40	40	22	10.4	6.3	20	18	11	RDE10	6	0.66	3° 10'	1
RSXF12040RS	★	40	32	40	16	8.4	5.6	18	13.5	9	RDE12	4	0.45	8° 00'	1
RSXF12050RS	★	50	40	40	22	10.4	6.3	20	18	11	RDE12	5	0.66	5° 30'	1
RSXF12052RS	★	52	40	40	22	10.4	6.3	20	18	11	RDE12	5	0.66	5° 15'	1
RSXF12063RS	★	63	40	40	22	10.4	6.3	20	18	11	RDE12	6	0.88	4° 00'	1
RSXF12066RS	★	66	55	50	27	12.4	7.0	25	20	14	RDE12	7	1.54	3° 45'	1
RSXF12080RS	★	80	55	50	27	12.4	7.0	25	20	14	RDE12	7	1.98	2° 50'	1
RSXF12100RS	★	100	70	50	32	14.4	8.5	32	46	-	RDE12	10	2.86	2° 10'	3
RSXF16063RS	★	63	50	40	22	10.4	6.3	20	18	11	RDE16	4	0.88	6° 00'	1
RSXF16080RS	★	80	55	50	27	12.4	7.0	25	20	14	RDE16	6	1.75	4° 10'	1
RSXF16100RS	★	100	70	50	32	14.4	8.5	32	46	-	RDE16	6	2.86	3° 00'	3
RSXF16125RS	★	125	80	63	40	16.4	9.5	29	52	29	RDE16	8	5.51	2° 20'	1
RSXF16160RS	★	160	130	63	40	16.4	9.5	29	88	-	RDE16	10	10.58	-	5

RSX Shell Mill - Metric (with Inch Arbor)

RSXF12080R	★	80	55	50	1.0 in.	9.5	6.0	25	20	13	RDE12	7	2.20	2° 50'	1
RSXF12100R	★	100	70	63	1.25 in.	12.7	8.0	32.5	46	28	RDE12	10	3.97	2° 10'	2
RSXF16080R	★	80	55	50	1.0 in.	9.5	6.0	25	20	13	RDE16	6	1.75	4° 10'	1
RSXF16100R	★	100	70	63	1.25 in.	12.7	8.0	32.5	46	28	RDE16	7	3.75	3° 00'	2
RSXF16125R	★	125	80	63	1.5 in.	15.9	10.0	35.5	55	30	RDE16	8	5.73	2° 20'	1
RSXF16160R	★	160	100	63	2.0 in.	19.0	11.0	38	72	-	RDE16	10	9.48	-	4

★: Worldwide Warehouse Item



Rake Angle	Radial	-5°
	Axial	10°

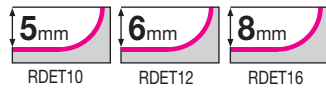

P	M	K	N	S	H
Steel	Stainless Steel	Cast Iron	Iron/Steel Matrix	Aluminum	Exotic Alloy
●	●	●	●	●	●

RSX Series

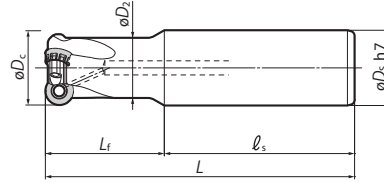

RSX End Mill - Metric

Catalog No.	Stock	ϕD_c	ϕD_s	ϕD_2	L_f	ℓ_f	L	Insert Type	# of Inserts	Weight (lbs)	Ramp Angle	Fig.
RSX10025ES	★	25	25	20.3	50	80	130	RDET10	2	0.88	10° 30'	1
RSX10032ES	★	32	32	27.1	50	80	130	RDET10	3	1.54	6° 45'	1
RSX12032ES	★	32	32	25.6	50	80	130	RDET12	2	1.54	12° 30'	1
RSXF10025ES	★	25	25	20.3	50	80	130	RDET10	3	0.88	10° 30'	1
RSXF10032ES	★	32	32	27.1	50	80	130	RDET10	4	1.54	6° 45'	1
RSXF12032ES	★	32	32	25.6	50	80	130	RDET12	3	1.54	12° 30'	1

★: Worldwide Warehouse Item

Insert & Parts Information



NEW

Inserts	P K M S					Dimensions	
	ACP200	ACK300	ACM100	ACM200	ACM300	I.C	Thickness
RDET10T3M0EN-G	●	●	●	●	●	0.394	0.156
RDET10T3M0EN-H	●	●	●	●	●	0.472	0.187
RDET1204M0EN-G	●	●	●	●	●	0.629	0.256
RDET1204M0EN-H	●	●	●	●	●		
RDET1606M0EN-G	●	●	●	●	●		
RDET1606M0EN-H	●	●	●	●	●		

●: U.S.A. Stock Item

Parts

Applicable Cutters	Wrench	Insert Screw	Recommended Tightening Torque Inch / LBs
RSX30000 Cutters	TRDR151P	BFTX03584IP	25
RSX40000 Cutters		BFTX04091P	25
RSX50000 Cutters	TRDR201P	BFTX04091P	45

ACM Grade Information

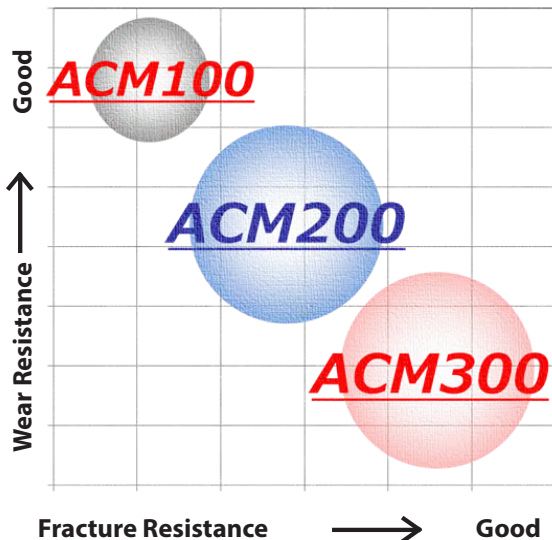

Cutting Conditions

ISO	Work Material	Hardness	Cutting Speed v_c (sfm) Min - Max	Feed Rate f_z (ipt) Min - Max	Recommended Grade		
M	Stainless Steel	Cr Based	Ferrite System	200 HB	500 - 650	0.006 - 0.014	ACM300
			Martensitic	200~330HB	250 - 600	0.006 - 0.014	ACM300
		Cr-Ni Based	Austenitic	200 HB	500 - 650	0.006 - 0.014	ACM300
			400 Series	230~270HB	250 - 600	0.006 - 0.014	ACM200
			Precipitation Hardening	330HB	200 - 525	0.006 - 0.014	ACM200
S	Titanium	Heat Resistant Alloy	Ni Based Material System	250~350HB	65 - 130	0.004 - 0.012	ACM100 ACM200
		Pure Titanium	(Rm400)	200 - 325	0.004 - 0.012		
		$\alpha+\beta$ Alloy System	(Rm1050)	130 - 200	0.004 - 0.012		

NOTE: The cutting conditions above are a guide. Actual Conditions will need to be adjusted according to machine rigidity, work clamp rigidity, cutting depth and other factors.

ACM100/300 (PVD)



Excellent wear resistance and improved adhesion resistance

- (1) High hardness
→ 1.5 times higher wear resistance
- (2) High compressive stress
→ 1.5 times higher toughness
- (3) Low reaction with work material
→ Improve adhesion resistance

ACM200 (CVD)

Higher stability with stress control technology

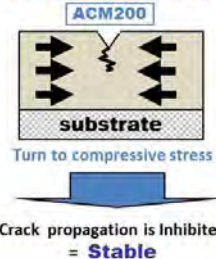
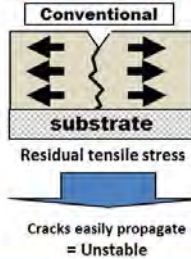

WRCX SERIES

Applicable Insert: QPMT, QPET

Multi-purpose Milling

Multi-application WaveMill



Features & Benefits

- 8 corner polygon inserts withstand extraordinary feed rates while providing improved finishes
- Highly durable cutter body made of special alloyed steel and protected by a hard surface treatment
- Wide application range that includes face milling, ramping, slotting, 3-D interpolation, and helical boring
- Pocket design eliminates insert rotation and breakage during aggressive machining
- Wide flute relief provides excellent chip evacuation

Application Examples

Face Milling

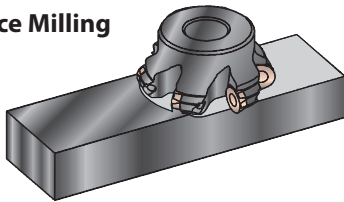

Slotting

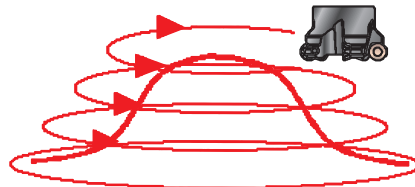
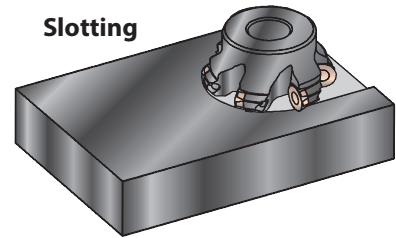

3-D Interpolation/Surfacing

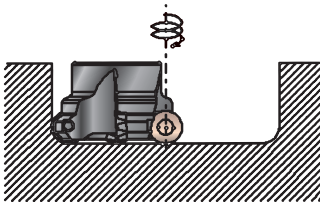

Helical Boring

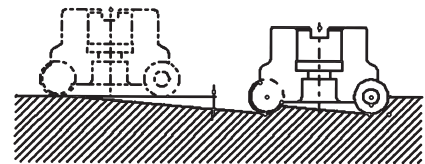

Ramping

Recommended Running Conditions

ISO	Work Material	Grades	øD = 1.00" - 1.25"		øD = 1.50" - 3.00"		øD = 4.00" - 6.00"	
			SFM	IPT	SFM	IPT	SFM	IPT
P	Carbon Steel	ACP200	260-395-525	.004-.012-.016	330-525-655	.008-.016-.024	490-655-820	.012-.016-.024
	Alloy Steel (HRC<40)	ACP200	195-330-460	.004-.008-.012	330-460-590	.008-.012-.016	330-525-655	.004-.012-.020
M	Stainless Steel (304)	ACP200, ACP300	195-330-395	.004-.006-.008	260-395-525	.004-.008-.012	525-590-655	.006-.008-.012
K	Gray Cast Iron	ACK200, ACK300	195-260-395	.004-.008-.012	260-395-525	.004-.008-.016	330-490-655	.004-.006-.008
N	Non-ferrous Metal	H1, DL1000	655-1640-3280	.004-.008-.012	655-1640-3280	.004-.012-.016	655-1640-3280	.008-.016-.024

Min.-OPTIMUM-Max.



Multi-purpose Milling Multi-application WaveMill

WRCX SERIES

Applicable Insert: QPMT, QPET

WRCX Endmill - Weldon/Cylindrical Shank - INCH										
Catalog Number	Stock	Dimensions (inch)					Insert Dia.	# of Inserts	Ramp Angle	Shank Style
		øD	ød	L	l ₁	l ₂				
WRCX31000EW	•	1.000	1.000	4.341	2.060	2.281	0.375	2	11°30'	Weldon
WRCX31000ELC	•	1.000	1.000	10.000	3.750	6.250	0.375	2	11°30'	Cylindrical
WRCX31250EW	•	1.250	1.250	4.341	2.060	2.281	0.375	3	7°30'	Weldon
WRCX31250ELC	•	1.250	1.250	10.000	3.750	6.250	0.375	3	7°30'	Cylindrical
WRCX31500EW	•	1.500	1.500	4.341	2.060	2.281	0.375	4	5°30'	Weldon
WRCX31500ELC	•	1.500	1.500	10.000	3.750	6.250	0.375	4	5°30'	Cylindrical
WRCX41250EW	•	1.250	1.250	4.341	2.060	2.281	0.500	2	18°30'	Weldon
WRCX41250ELC	•	1.250	1.250	10.000	3.750	6.250	0.500	2	18°30'	Cylindrical
WRCX41500EW	•	1.500	1.500	4.341	2.060	2.281	0.500	3	12°30'	Weldon
WRCX41500ELC	•	1.500	1.500	10.000	3.750	6.250	0.500	3	12°30'	Cylindrical

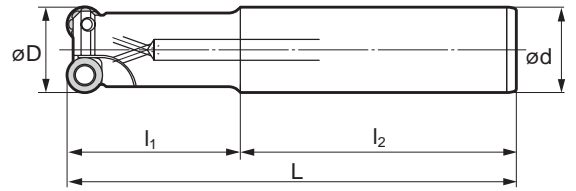

WRCX Shell Mill - INCH												
Catalog Number	Stock	Dimensions (mm)								Insert Dia.	# of Inserts	Ramp Angle
		øD	ød	F	ød ₁	ød ₂	ød ₃	E	a			
WRCX32000R	•	2.000	1.50	1.75	0.750	0.406	0.609	1.020	0.312	0.375	4	5°30'
WRCX42000R	•	2.000	1.50	1.75	0.750	0.406	0.609	1.020	0.312	0.500	4	7°30'
WRCX42500R	•	2.500	1.75	1.75	1.000	0.531	0.797	1.020	0.375	0.500	4	5°30'
WRCX43000R	•	3.000	2.25	1.75	1.000	0.531	0.797	1.020	0.375	0.500	5	4°
WRCX63000R	•	3.000	2.25	1.75	1.000	0.531	0.797	1.020	0.375	0.750	5	7°30'
WRCX44000R	•	4.000	2.87	2.00	1.250	0.656	1.000	1.020	0.500	0.500	6	2°30'
WRCX64000R	•	4.000	2.87	2.00	1.250	0.656	1.000	1.020	0.500	0.750	6	4°30'
WRCX84000R	•	4.000	2.87	2.00	1.250	0.656	1.000	1.020	0.500	1.000	6	6°
WRCX65000R	•	5.000	3.75	2.50	1.500	-	2.000	1.060	0.625	0.750	6	3°15'
WRCX85000R	•	5.000	3.75	2.50	1.500	-	2.000	1.060	0.625	1.000	6	4°15'
WRCX66000R	•	6.000	3.75	2.50	1.500	-	2.000	1.060	0.625	0.750	8	3°15'
WRCX86000R	•	6.000	3.70	2.50	1.500	-	2.000	1.060	0.625	1.000	8	3°15'

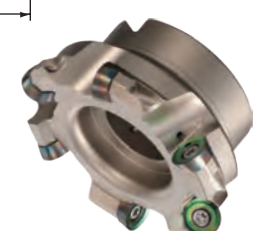
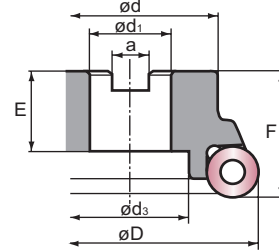

Indexable Milling
Shoulder Milling
Face Milling
High Feed Milling
Multi-purpose
Modular Tooling
UFO & SumiMill
Discontinued

Inserts										
Catalog Number	Fig. 1					Fig. 2				
	ACP100	ACP200	ACP300	ACK300	DL1000	H1	Insert Dia.	T	Max D.O.C.	Fig.
QPMT32.510PPEN	•	•	•	•			0.375	0.156	0.1875	1
QPMT32.510PPEN-H	•	•	•	•			0.375	0.156	0.1875	2
QPMT4312PPEN	•	•	•	•			0.500	0.1875	0.250	1
QPMT4312PPEN-H	•	•	•	•			0.500	0.1875	0.250	2
QPMT6416PPEN	•	•	•	•			0.750	0.250	0.375	1
QPMT6416PPEN-H	•	•	•	•			0.750	0.250	0.375	2
QPMT8424PPEN	•	•	•	•			1.000	0.250	0.500	1
QPMT8424PPEN-H	•	•	•	•			1.000	0.250	0.500	2
QPET32.510PPENS*					•	•	0.375	0.156	0.1875	1
QPET4312PPENS*					•	•	0.500	0.1875	0.250	1
QPET6416PPENS*					•	•	0.750	0.250	0.375	1

*4 indexes due to wiper

Coolant Through Bolts	
Catalog Number	Cutter Size
BFXH 3/8 x 1	2.00"
BFXH 1/2 x 1 1/4	2.50"
BFXH 1/2 x 1 1/4	3.00"
BFXH 5/8 x 1 1/4	4.00"
BFXH 3/4 x 1 1/2	5.00"

Hardware		
Cutter	Wrench	Screw
WRCX3□□□R	TRDR15IP	BFTX03584IP
WRCX4□□□R		BFTX0409IP
WRCX6□□□R	TRDR20IP	BFTX0511IP
WRCX8□□□R		BFTX0615IP



Features & Benefits

- Dedicated 2-flute ball nose endmill designed specifically for high performance rough cutting of steels, alloys, and tool steels
- Provides maximum cutter efficiency for the most time consuming portion of most machining operations—roughing
- Neutral insert edge with positive relief on face is incredibly strong but consumes low amounts of horsepower
- Strong tool steel body designed with anti-rotation lugs insures that cutting inserts are movement free, even at heavy feed rates and high cutting speeds
- “X” style cutter bodies allow the creation of part side walls with as little as three degrees of draft without side wall interference from the tool tip all the way to the face of a standard ISO Weldon shank tool holder
- Three separate lengths per diameter allow the end user to choose the best tool for the job at hand
- Cylindrical shank tooling allows extended reach, and the possibility of customization along with the correct design for use with the latest high strength milling chucks
- Negative assembly tolerancing eliminates 3-dimensional surface violations due to cumulative tooling errors
- The perfect 1-2 punch for the roughing of dies and mold work when combined with our WRCX cutters



• Max. D.O.C.
Radial & Axial

Max. 50% of ØD

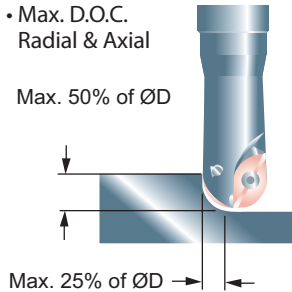

Max. 25% of ØD

• Anti-rotational design

Prevents insert breakage by positively locking into A, B, & C.

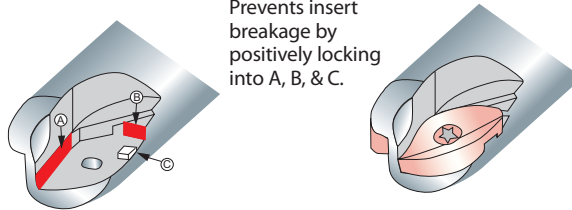

Inserts for all WBMR Series Ballnose Endmills

Catalog Number	Style	Position	A	B	T	R	Applicable Cutters
ZNMT3CX	1	center	0.720	0.361	0.189	0.375	WBMR075SX, MX, LX, or LCX
ZNMT3SX	2	outer	0.795	0.280	0.167	0.375	
ZNMT4CX	1	center	0.887	0.480	0.224	0.500	WBMR100SX, MX, LX, LCX, SLX, MLX, or LLX
ZNMT4SX	2	outer	0.913	0.369	0.217	0.500	
ZNMT5CX	1	center	1.150	0.615	0.281	0.625	WBMR125SX, MX, LX, LCX, SLX, MLX, or LLX
ZNMT5SX	2	outer	1.185	0.472	0.263	0.625	
ZNMT6X	3	center & outer	1.430	0.781	0.348	0.750	WBMR150SX, MX, or LX
ZNMT8X	3	center & outer	1.705	1.012	0.400	1.000	WBMR200SX, MX, or LX
SPMT09T308*	4	peripheral insert	0.375 (I.C.)	N/A	0.156	.031	WBMR100 & 125 SLX, MLX, or LLX

*Used in “Extended Length of Cut” Endmills only



Multi-purpose Milling Ballnose Roughing WaveMill

WBMR

Applicable Insert: ZNMT

BALLNOSE ENDMILL

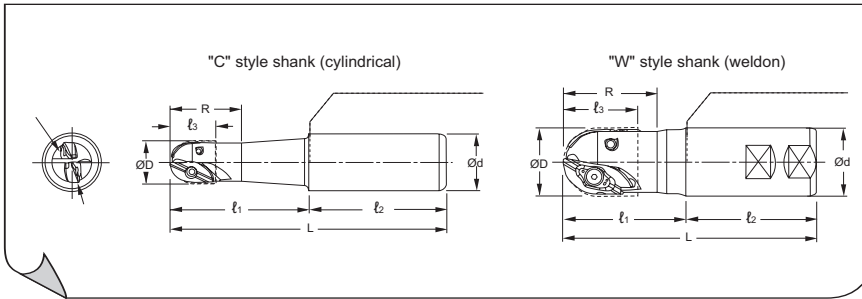

WBMR Cutters (Standard Length)										
Catalog Number	Stock	Dimensions (Inches)							Inserts	
		ØD	Ød	Shank	L	l ₃	l ₁	l ₂		R
WBMR075SX	•	0.750	1.000	W	4.546	0.752	2.285	2.261	1.181	ZNMT3_X
WBMR075MX	•	0.750	1.000	W	6.046	0.752	3.785	2.261	1.181	ZNMT3_X
WBMR075LX	•	0.750	1.000	W	7.546	0.752	5.285	2.261	1.181	ZNMT3_X
WBMR100SX	•	1.000	1.250	W	4.796	0.917	2.535	2.261	1.378	ZNMT4_X
WBMR100MX	•	1.000	1.250	W	6.546	0.917	4.285	2.261	1.378	ZNMT4_X
WBMR100LX	•	1.000	1.250	W	8.296	0.917	6.035	2.261	1.378	ZNMT4_X
WBMR100LCX	•	1.000	1.250	C	11.750	0.917	2.535*	9.215**	1.378	ZNMT4_X
WBMR125SX	•	1.250	1.250	W	4.796	1.228	2.535	2.261	1.693	ZNMT5_X
WBMR125MX	•	1.250	1.250	W	6.796	1.228	4.535	2.261	1.693	ZNMT5_X
WBMR125LX	•	1.250	1.250	W	8.796	1.228	6.535	2.261	1.693	ZNMT5_X
WBMR125LCX	•	1.250	1.250	C	13.750	1.228	2.535*	11.215**	1.693	ZNMT5_X
WBMR150SX	•	1.500	1.500	W	5.223	1.543	2.535	2.688	1.940	ZNMT6X
WBMR150MX	•	1.500	1.500	W	7.779	1.543	4.535	3.244	3.688	ZNMT6X
WBMR150LX	•	1.500	1.500	W	9.779	1.543	6.535	3.244	5.488	ZNMT6X
WBMR200SX	•	2.000	2.000	W	6.029	1.862	2.785	3.244	2.256	ZNMT8X
WBMR200MX	•	2.000	2.000	W	8.279	1.862	5.035	3.244	4.138	ZNMT8X
WBMR200LX	•	2.000	2.000	W	10.529	1.862	7.285	3.244	6.163	ZNMT8X

Hardware		
Catalog Number	Screw	Wrench
WBMR075□X	BFTX0307N	TRX10
WBMR100□X	BFTX0409N	TRD15
WBMR125□X	BFTX0511N	TRD20
WBMR150□X	BFTX0619N	TRD25
WBMR200□X	BFTX0619N	TRD25

Torque specifications for BFTX0307N insert screw is 18-22 in/lbs.
 Torque specifications for BFTX0409N insert screw is 27-31 in/lbs.
 Torque specifications for BFTX0511N insert screw is 44-49 in/lbs.
 Torque specifications for BFTX0619N insert screw is 62-67 in/lbs.

Note: All 0.750"-1.250" cutters require (1) Center "CX" insert and (1) Outer "SX" insert to accomplish the "D" diameter specified. The tolerance of the "D" diameter is +.000/-.020.

- *Represents relieved portion of cutter body
- **Represents straight portion of cutter body
- USA stocked item

Inserts										
Sumitomo Cat. No.	Coated					Dimensions (Inches)				
	ACZ310	ACZ330	ACZ350	ACP200	ACP300	A	B	T	R	Figure
ZNMT3CX	▲	▲	▲	•	•	0.720	0.361	0.189	0.375	1
ZNMT3SX	▲	▲	▲	•	•	0.795	0.280	0.167	0.375	2
ZNMT4CX	▲	▲	▲	•	•	0.887	0.480	0.224	0.500	1
ZNMT4SX	▲	▲	▲	•	•	0.913	0.369	0.217	0.500	2
ZNMT5CX	▲	▲	▲	•	•	1.150	0.615	0.281	0.625	1
ZNMT5SX	▲	▲	▲	•	•	1.185	0.472	0.263	0.625	2
ZNMT6X	▲	▲	▲	•	•	1.430	0.781	0.348	0.750	3
ZNMT8X	▲	▲	▲	•	•	1.705	1.012	0.400	1.000	3

- "CX" denotes center insert (Fig. 1)
- "SX" denotes outer insert (Fig. 2)
- Fig. 3 inserts are used in both center and outer position.
- USA stocked item

**See pages 613-615
for recommended
running parameters**



Indexable Milling
 Shoulder Milling
 Face Milling
 High Feed Milling
 Multi-purpose
 Modular Tooling
 UFO & SumiMill
 Discontinued

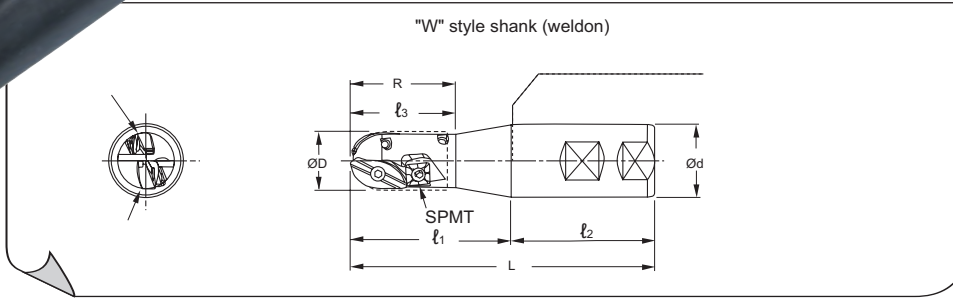

WBMR Cutters (Extended Length)												
Catalog Number	Stock	Dimensions (Inches)									Inserts 1 & 2	Insert style 4
		ØD	Ød	Shank	L	l ₃	l ₁	l ₂	R			
WBMR100SLX	•	1.000	1.250	W	4.796	1.535	2.535	2.261	1.653	ZNMT4_X	SPMT09T308	
WBMR100MLX	•	1.000	1.250	W	6.546	1.535	4.285	2.261	1.653	ZNMT4_X	SPMT09T308	
WBMR100LLX	•	1.000	1.250	W	8.296	1.535	6.035	2.261	1.653	ZNMT4_X	SPMT09T308	
WBMR125SLX	•	1.250	1.250	W	4.796	1.835	2.535	2.261	1.968	ZNMT5_X	SPMT09T308	
WBMR125MLX	•	1.250	1.250	W	6.796	1.835	4.535	2.261	1.968	ZNMT5_X	SPMT09T308	
WBMR125LLX	•	1.250	1.250	W	8.796	1.835	6.535	2.261	1.968	ZNMT5_X	SPMT09T308	

Note: All 0.750" - 1.250" cutters require (1) Center "CX" insert and (1) Outer "SX" insert to accomplish the "D" diameter specified.

The tolerance of the "D" diameter is +.000/-0.020.

*This dimension represents the actual "extension from holder."

- USA stocked item

Inserts										
Sumitomo Cat. No.	Coated					Dimensions (Inches)				Figure
	ACZ310	ACZ330	ACZ350	ACK300	ACP200	A	B	T	R	
	ZNMT3CX	▲	▲	▲	•	•	0.720	0.361	0.189	
ZNMT3SX	▲	▲	▲	•	•	0.795	0.280	0.167	0.375	2
ZNMT4CX	▲	▲	▲	•	•	0.887	0.480	0.224	0.500	1
ZNMT4SX	▲	▲	▲	•	•	0.913	0.369	0.217	0.500	2
ZNMT5CX	▲	▲	▲	•	•	1.150	0.615	0.281	0.625	1
ZNMT5SX	▲	▲	▲	•	•	1.185	0.472	0.263	0.625	2
ZNMT6X	▲	▲	▲	•	•	1.430	0.781	0.348	0.750	3
ZNMT8X	▲	▲	▲	•	•	1.705	1.012	0.400	1.000	3

"CX" denotes center insert (Fig. 1)

"SX" denotes outer insert (Fig. 2)

▲ USA Limited Availability Item

- USA stocked item

Hardware			
Catalog Number	Insert	Screw	Wrench
WBMR100□LX	ZNMT4_X	BFTX0409N	TRD15
WBMR125□LX	ZNMT5_X	BFTX0511N	TRD20
WBMR□□□□LX	SPMT09T308	BFTX0409N	TRD15

Torque specifications for BFTX0409N insert screw is 27-31 in/lbs.

Torque specifications for BFTX0511N insert screw is 44-49 in/lbs.

Sumitomo Cat. No.	Dimensions (Inches)			
	I.C.	T	R	Figure
SPMT09T308	0.375	0.156	0.031	

- USA stocked item

**See pages 613-615
for recommended
running parameters**





Features & Benefits

- Highly accurate fully ground insert offers reliable repeatability (within 0.0002") to simplify the finish milling processes of complex 3-dimensional work
- Multi ground locking surfaces and screw-on insert design makes the cutter assembly super strong and rigid
- The tool body design matches that of the WBMR line to provide worry-free programming, insuring no side wall interference down to as little as 3° of draft without body modification of weldon style tools
- Each diameter is offered in multiple lengths to allow application of the shortest, most efficient length for the job
- ACZ120, ZX coated carbide inserts efficiently cut hardened mold and die steels with low cutting forces and long tool life
- Sharp helical cutting edge generates excellent surface finishes to reduce or eliminate time consuming hand polishing operations

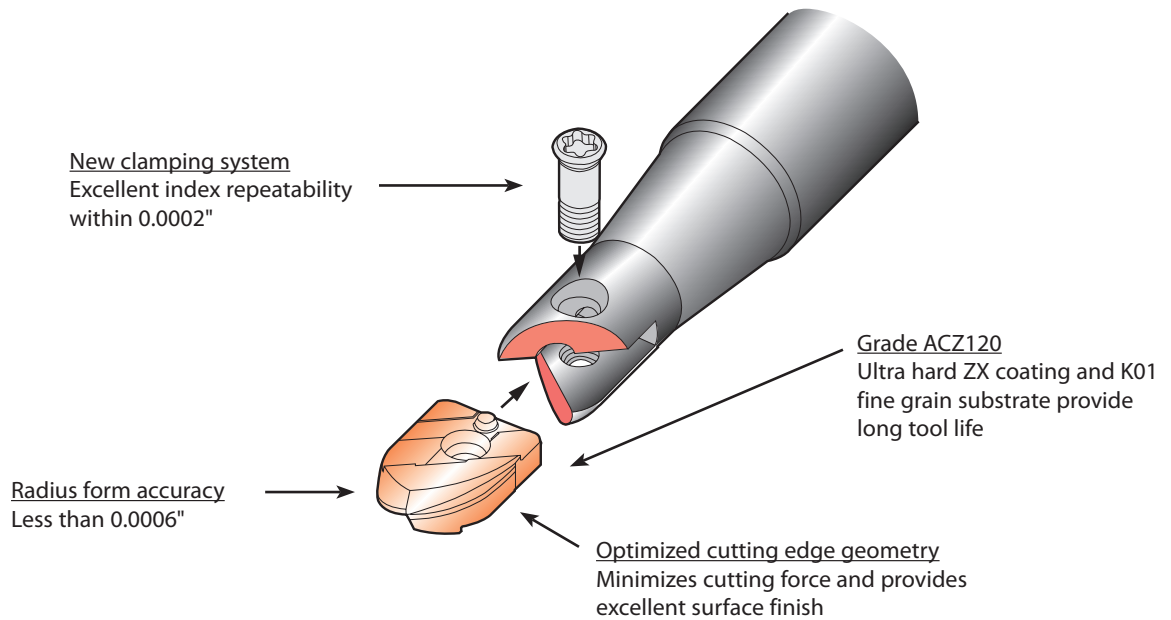

Indexable Milling
Shoulder Milling
Face Milling
High Feed Milling
Multi-purpose
Modular Tooling
UFO & SumiMill
Discontinued





"W" style shank (weldon)

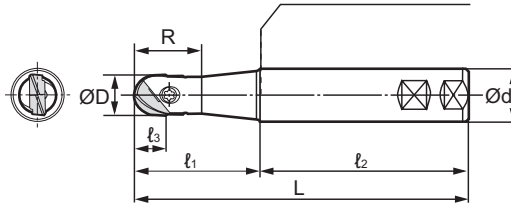

WBMF Cutters (Standard Length)										
Catalog Number	Stock	Dimension (inches)								Inserts
		D	d	Shank	L	ℓ1	ℓ2	ℓ3	R	
WBMF10500S	•	0.50	0.625	W	3.678	1.772	1.906	0.427	0.782	ZPGU2S
WBMF10500M	•	0.50	0.625	W	4.428	2.522	1.906	0.427	0.782	ZPGU2S
WBMF10500L	•	0.50	0.750	W	5.300	3.270	2.031	0.427	0.782	ZPGU2S
WBMF10625S	•	0.63	0.750	W	3.801	1.770	2.031	0.470	1.000	ZPGU2.5S
WBMF10625M	•	0.63	0.750	W	4.551	2.520	2.031	0.470	1.000	ZPGU2.5S
WBMF10625L	•	0.63	1.000	W	5.546	3.265	2.281	0.470	1.000	ZPGU2.5S
WBMF10750S	•	0.75	1.000	W	4.546	2.265	2.281	0.572	1.250	ZPGU3S
WBMF10750M	•	0.75	1.000	W	6.046	3.765	2.281	0.572	1.250	ZPGU3S
WBMF10750L	•	0.75	1.000	W	7.546	5.265	2.281	0.572	1.250	ZPGU3S
WBMF10750LC	•	0.75	1.000	W	9.500	2.250	7.250	0.572	1.250	ZPGU3S
WBMF11000S	•	1.00	1.250	W	4.793	2.512	2.281	0.736	1.500	ZPGU4S
WBMF11000M	•	1.00	1.250	W	6.546	4.265	2.281	0.736	1.500	ZPGU4S
WBMF11000L	•	1.00	1.250	W	8.296	6.015	2.281	0.736	1.500	ZPGU4S
WBMF11250S	•	1.25	1.250	W	4.796	2.515	2.281	0.919	1.750	ZPGU5S
WBMF11250M	•	1.25	1.250	W	6.796	4.515	2.281	0.919	1.750	ZPGU5S
WBMF11250L	•	1.25	1.250	W	8.796	6.515	2.281	0.919	1.750	ZPGU5S

• USA stocked item

Inserts

Sumitomo Cat. No.	Coated	Dimensions (Inches)					
		ØD	L	A	T	R	
ZPGU2S	•	0.500	0.427	0.722	0.220	0.250	
ZPGU2.5S	•	0.625	0.470	0.805	0.240	0.3125	
ZPGU3S	•	0.750	0.572	0.946	0.280	0.375	
ZPGU4S	•	1.000	0.736	1.130	0.299	0.500	
ZPGU5S	•	1.250	0.919	1.392	0.339	0.625	

• USA stocked item

Hardware

Catalog Number	Screw	Wrench
WBMF10500□	BFTG0409F	TRD15
WBMF10625□	BFTG0513F	TRD20
WBMF10750□	BFTG0617F	TRD25
WBMF11000□	BFTG0621F	TRD25
WBMF11250□	BFTG0825F	TRD25

**See pages 592-593
for recommended
running parameters**





Features & Benefits

- Multi-functional cutter efficiently performs the cutting operations of several tools
- Excellent for ramping, helical cutting, pocketing, and drilling
- Inserts interchangeable with those used on the WEM and WRM cutters
- Strong high rake inserts provide smooth cutting action

■ Insert orientation of WMM type cutter

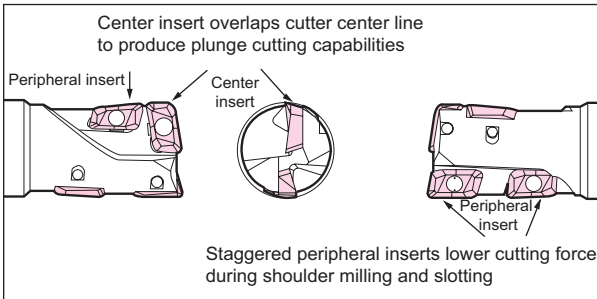

■ Multi-purpose Applications

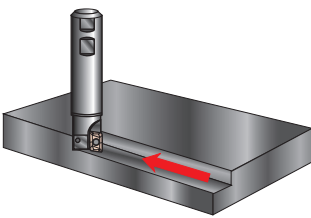

Shoulder milling

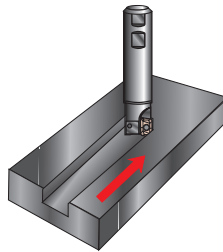

Slotting

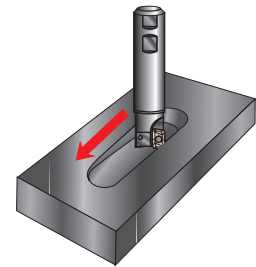

Ramping

Max. depth = effective depth of cut
Ramping Angle = 0~30°

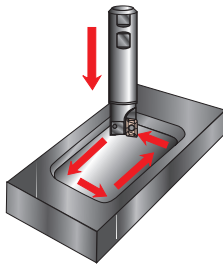

Pocketing

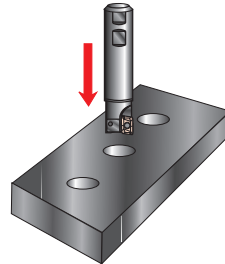

Drilling

Always use step feed (.020"-.040") when drilling. It is recommended that the drill depth is $\leq 0.6D$.

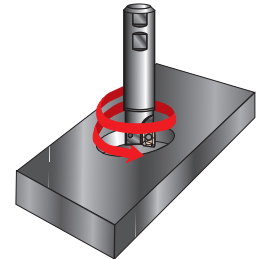

Helical boring
Boring-expanding

- a hole of 1.2-1.8 x diameter without prepared hole
- Helical angle = 0° to 30°



Inch
WMM10000 APET10
APMT10

Inch
WMM16000 APET16
APMT16

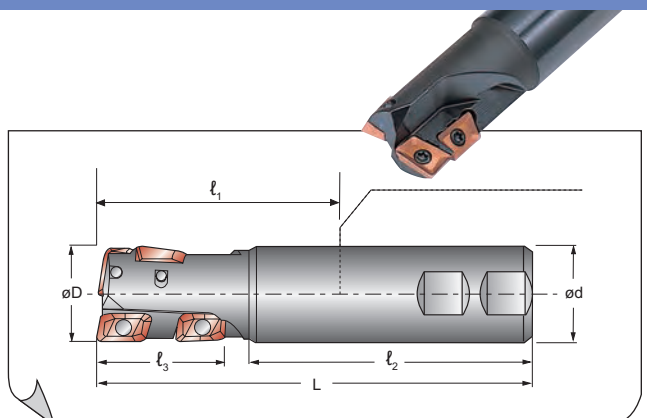
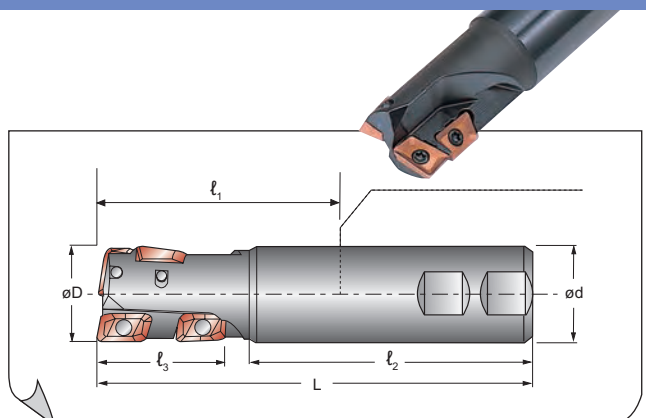

WMM Endmills

Catalog Number	Stock	Dimensions (Inches)						l ₃ Max D.O.C.	# of Inserts
		ØD	Ød	L	l ₁	l ₂	l ₃		
WMM10100M	•	1.000	1.000	4.000	1.7394	2.281	1.050	4	
WMM10125M	•	1.250	1.250	5.000	2.7394	2.281	1.390	5	

WMM Endmills

Catalog Number	Stock	Dimensions (Inches)						l ₃ Max D.O.C.	# of Inserts
		ØD	Ød	L	l ₁	l ₂	l ₃		
WMM16150M	•	1.500	1.250	5.000	2.7394	2.281	1.540	4	

• USA stocked item

• USA stocked item

Inserts

Sumitomo Cat. No.	Coated		Uncoated		Dimensions (Inches)					
	ACZ310	ACZ330	ACZ350	DL1000	L	W	T	R	Facet Width	Fig.
APET103504PDER	•	•	•		0.394	0.250	0.138	0.016	0.0315	1
APET103504PDR-J	•	•	•	•	0.394	0.250	0.138	0.016	0.0315	1
APMT103504PDER	•	•	•		0.394	0.250	0.138	0.016	N/A	2
APMT103504PDER-H	•	•	•		0.394	0.250	0.138	0.016	N/A	2
APMT103508PDER	•	•	•		0.394	0.250	0.138	0.031	N/A	2
APMT103508PDER-H	•	•	•		0.394	0.250	0.138	0.031	N/A	2
APMT103512PDER	•	•	•		0.394	0.250	0.138	0.047	N/A	2
APMT103512PDER-H	•	•	•		0.394	0.250	0.138	0.047	N/A	2

"J" denotes inserts with a polished face.
"H" denotes inserts with heavy edge preparation.
• USA stocked item

Inserts

Sumitomo Cat. No.	Coated		Uncoated		Dimensions (Inches)					
	ACZ310	ACZ330	ACZ350	DL1000	L	W	T	R	Facet Width	Fig.
APET160504PDR-J				•	0.630	0.375	0.218	0.016	0.0827	1
APET160508PDER	•	•	•		0.630	0.375	0.218	0.031	0.071	1
APET160508PDR-J	•	•	•	•	0.630	0.375	0.218	0.031	0.071	1
APMT160508PDER	•	•	•		0.630	0.375	0.218	0.031	N/A	2
APMT160508PDER-H	•	•	•		0.630	0.375	0.218	0.031	N/A	2
APMT160512PDER	•	•	•		0.630	0.375	0.218	0.047	N/A	2
APMT160512PDER-H	•	•	•		0.630	0.375	0.218	0.047	N/A	2
APMT160516PDER	•	•	•		0.630	0.375	0.218	0.063	N/A	2
APMT160516PDER-H	•	•	•		0.630	0.375	0.218	0.063	N/A	2
APMT160532PDER-H	•	•	•		0.630	0.375	0.218	0.125	N/A	2

"J" denotes inserts with a polished face.
"H" denotes inserts with heavy edge preparation.
• USA stocked item

Hardware

Catalog Number	Screw	Wrench
WMM10□□□M	BFTX02506N	TRD08

Torque specifications for BFTX02506N insert screw=10-14 inch/lbs.

Hardware

Catalog Number	Screw	Wrench
WMM16□□□M	BFTX03584	TRD15

Torque specifications for BFTX03584 insert screw=27-31 inch/lbs.

**See pages 613-615
for recommended
running parameters**



MODULAR TOOLING

Pages 393-399



MODULAR TOOLING

PAGES

Modular Tools Features & Benefits	394-395
WEX Type	396
RSX Type	397
MSX Type	398
TSX Type	399

Indexable Milling

Shoulder Milling

Face Milling

High Feed Milling

Multi-purpose

Modular Tooling

UFO & SumiMill

Discontinued



Features & Benefits

Exchangeable head endmills are available in 3 types!

- 1) **WEX Type** Shoulder Endmill
- 2) **RSX Type** Multi-purpose Radius Endmill
- 3) **MSX Type** Ultra-High Feed Endmill
- 4) **TSX Type** Tangential Shoulder Endmill

Characteristics

Carbide arbors can be applied up to 6 times diameter to length ratio.

Modular Type + Carbide Arbor

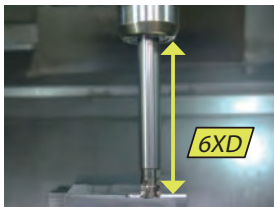

Work Material: 1049
 Tool: WEX2025M12Z4 ($\phi 25 \times 4$ flutes)
 Cutting Conditions: $v_c=328$ SFM $f_z=0.004$ IPT
 $a_e=.315$ " mm x 3 D.O.C=.079" Equipment = M/C BT50

Standard Type (Integrated Arbor)

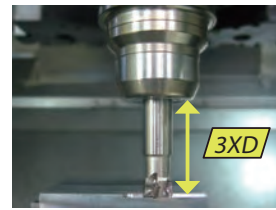

Application Range

(Work Material: 1049 Equipment: Vertical M/C BT50 Dry)

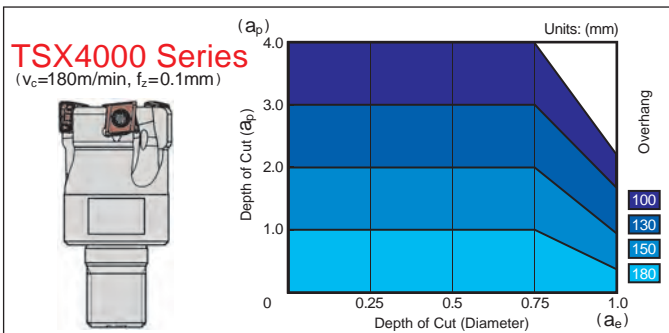
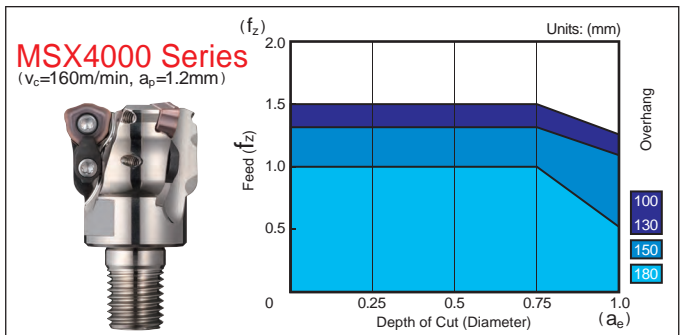
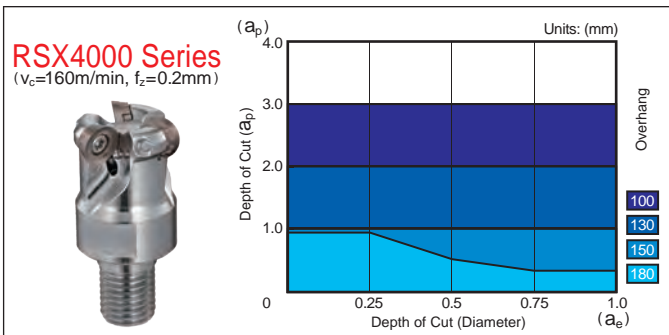
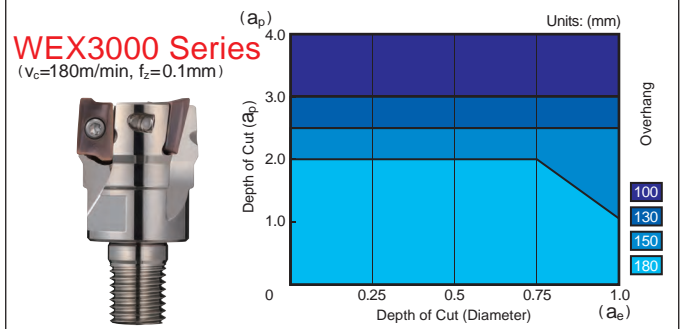
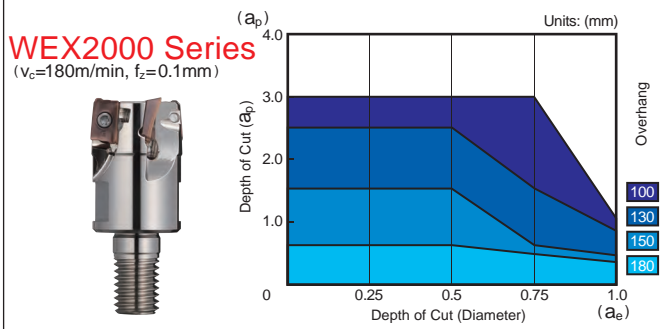

Recommended Tightening Torque (N·m)

*Notes about tightening the head.

- When attaching the head to an arbor, follow the standard tightening torque in the table below.
- Check the mounting screw size for the head and arbor beforehand.

Screw Size	Torque (N·m)
M8	23
M10	46
M12	80
M16	90

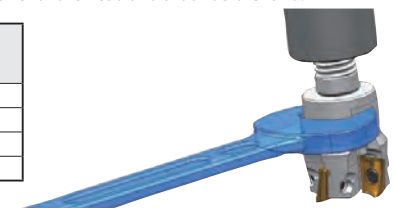

Note: These tables indicate reference machining conditions. Actual machining parameters should be adjusted based on machine rigidity and work clamp rigidity.



Suitable for milling with **long overhangs** when combined with carbide or steel arbors

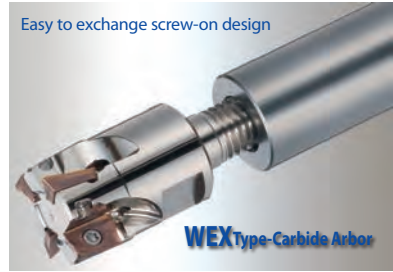

Modular Tools Special Arbors (Carbide Arbors/Steel Arbors)

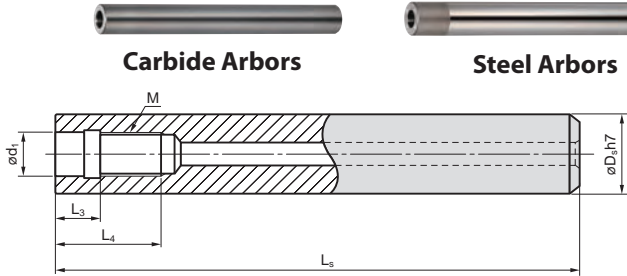

★ Worldwide Warehouse Item

Carbide Arbors								
Catalog Number	Stock	Dimension (mm)						
		M	ød ₁	øD ₅	L ₅	L ₃	L ₄	L ₅ *
MA15M08L120C	★	M8	8.5	15	120	10	18	145
MA15M08L160C	★	M8	8.5	15	160	10	18	185
MA16M08L120C	★	M8	8.5	16	120	10	18	145
MA16M08L160C	★	M8	8.5	16	160	10	18	185
MA18M10L150C	★	M10	10.5	18	150	10	20	180
MA18M10L200C	★	M10	10.5	18	200	10	20	230
MA20M10L150C	★	M10	10.5	20	150	10	20	180
MA20M10L200C	★	M10	10.5	20	200	10	20	230
MA23M12L200C	★	M12	12.5	23	200	10	22	235
MA23M12L250C	★	M12	12.5	23	250	10	22	285
MA25M12L200C	★	M12	12.5	25	200	10	22	235
MA25M12L250C	★	M12	12.5	25	250	10	22	285
MA28M16L200C	★	M16	17.0	28	200	10	24	240
MA28M16L300C	★	M16	17.0	28	300	10	24	340
MA32M16L200C	★	M16	17.0	32	200	10	24	240
MA32M16L300C	★	M16	17.0	32	300	10	24	340

Steel Arbors								
Catalog Number	Stock	Dimension (mm)						
		M	ød ₁	øD ₅	L ₅	L ₃	L ₄	L ₅
MA16M08L120S	★	M8	8.5	16	120	10	18	145
MA18M10L150S								
MA20M10L150S	★	M10	10.5	20	150	10	20	180
MA25M12L200S	★	M12	12.5	25	200	10	22	235
MA28M16L200S								
MA32M16L200S	★	M16	17.0	32	200	10	24	240

★ Worldwide Warehouse Item

Arbor Identification

MA 15 M08 L120 C

(1) Cutter Series (2) Shank Diameter (3) Mounting Screw (4) Arbor Length (5) C: Carbide S: Steel

Modular Tools Adapters

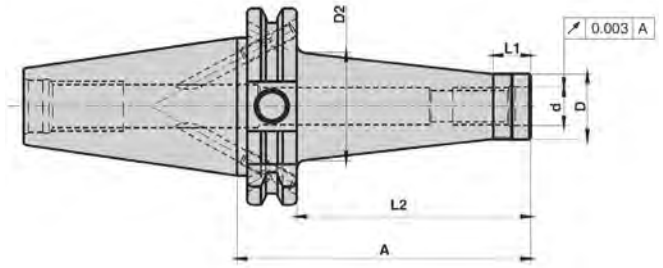

Modular Adapters - SK40

Catalog Number	Stock	Dimension (mm)						
		M	d	D ₁	D ₂	A	L ₁	L ₂
SMA-M8-69-SK40	★	M8	8.5	13.8	23	69	12	49.9
SMA-M8-94-SK40	★	M8	8.5	13.8	25	94	12	74.9
SMA-M8-119-SK40	★	M8	8.5	13.8	30	119	12	99.9
SMA-M10-69-SK40	★	M8	8.5	18.0	25	69	12	49.9
SMA-M10-94-SK40	★	M10	10.5	18.0	30	94	12	74.9
SMA-M10-119-SK40	★	M10	10.5	18.0	35	119	12	99.9
SMA-M10-169-SK40	★	M10	10.5	18.0	45	169	12	149.9
SMA-M12-69-SK40	★	M10	12.5	21.0	30	69	12	49.9
SMA-M12-94-SK40	★	M12	12.5	21.0	35	94	12	74.9
SMA-M12-119-SK40	★	M12	12.5	21.0	38	119	12	99.9
SMA-M12-169-SK40	★	M12	12.5	21.0	48	169	12	149.9
SMA-M16-69-SK40	★	M12	17.0	29.0	34	69	12	49.9
SMA-M16-94-SK40	★	M16	17.0	29.0	35	94	12	74.9
SMA-M16-119-SK40	★	M16	17.0	29.0	40	119	12	99.9
SMA-M16-169-SK40	★	M16	17.0	29.0	48	169	12	149.9

Note: The above holders require an M16 thread retention knob

Modular Adapters - SK50

Catalog Number	Stock	Dimension (mm)						
		M	d	D ₁	D ₂	A	L ₁	L ₂
SMA-M8-69-SK50	★	M8	8.5	13.8	23	69	12	49.9
SMA-M8-119-SK50	★	M8	8.5	13.8	30	119	12	74.9
SMA-M8-169-SK50	★	M8	8.5	13.8	45	169	12	99.9
SMA-M10-69-SK50	★	M10	10.5	18.0	25	69	12	49.9
SMA-M10-119-SK50	★	M10	10.5	18.0	35	119	12	99.9
SMA-M10-169-SK50	★	M10	10.5	18.0	45	169	12	149.9
SMA-M12-69-SK50	★	M12	12.5	21.0	30	69	12	49.9
SMA-M12-119-SK50	★	M12	12.5	21.0	38	119	12	99.9
SMA-M12-169-SK50	★	M12	12.5	21.0	52	169	12	149.9
SMA-M16-69-SK50	★	M16	17.0	29.0	34	69	12	49.9
SMA-M16-119-SK50	★	M16	17.0	29.0	40	119	12	99.9
SMA-M16-169-SK50	★	M16	17.0	29.0	48	169	12	149.9

Note: The above holders require an M24 thread retention knob



Indexable Milling
Shoulder Milling
Face Milling
High Feed Milling
Multi-purpose
Modular Tooling
UFO & SumiMill
Discontinued

WEX Series

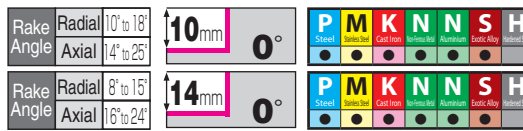

WEX2000M

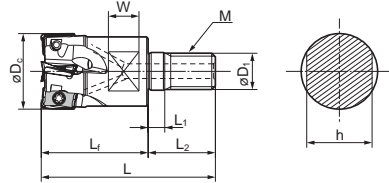

WEX3000M

★ Worldwide Warehouse Item Inserts are not included

Modular Head - METRIC

Catalog Number	Stock	Dimensions (mm)								No. of Teeth	
		ϕD_c	ϕD_1	M	L	L_f	L_1	L_2	W		h
WEX 2016M08Z2	★	16	8.5	M8	42	25	5	17	8	13	2
WEX 2018M08Z2	★	18	8.5	M8	42	25	5	17	8	13	2
WEX 2020M10Z3	★	20	10.5	M10	49	30	5	19	8	15	3
WEX 2022M10Z3	★	22	10.5	M10	49	30	5	19	8	15	3
WEX 2025M12Z4	★	25	12.5	M12	56	35	5	21	10	19	4
WEX 2028M12Z4	★	28	12.5	M12	56	35	5	21	10	19	4
WEX 2030M16Z4	★	30	17.0	M16	63	40	5	23	10	24	4
WEX 2032M16Z5	★	32	17.0	M16	63	40	5	23	10	24	5
WEX 2040M16Z6	★	40	17.0	M16	63	40	5	23	10	24	6

Modular Head (WEX3000M) - METRIC

Catalog Number	Stock	Dimensions (mm)								No. of Teeth	
		ϕD_c	ϕD_1	M	L	L_f	L_1	L_2	W		h
WEX 3025M12Z2	★	25	12.5	M12	56	35	5	21	10	19	2
WEX 3028M12Z2	★	28	12.5	M12	56	35	5	21	10	19	2
WEX 3030M16Z3	★	30	17.0	M16	63	40	5	23	10	24	3
WEX 3032M16Z3	★	32	17.0	M16	63	40	5	23	10	24	3
WEX 3035M16Z3	★	35	17.0	M16	63	40	5	23	10	24	3
WEX 3040M16Z4	★	40	17.0	M16	63	40	5	23	10	24	4

Modular Head - INCH

Catalog Number	Stock	Dimensions (in.)								No. of Teeth	
		ϕD_c	ϕD_1	M	L	L_f	L_1	L_2	W		h
WEX20750M10Z3	○	0.750	0.413	M10	1.929	1.181	0.197	0.748	0.315	0.591	3
WEX21000M12Z4	○	1.000	0.492	M12	2.205	1.378	0.197	0.827	0.394	0.748	4
WEX21250M16Z5	○	1.250	0.669	M16	2.480	1.575	0.197	0.906	0.394	0.945	5
WEX21500M16Z6	○	1.500	0.669	M16	2.480	1.575	0.197	0.906	0.394	0.945	6

Modular Head - INCH

Catalog Number	Stock	Dimensions (in.)								No. of Teeth	
		ϕD_c	ϕD_1	M	L	L_f	L_1	L_2	W		h
WEX31000M12Z2	○	1.000	0.492	M12	2.205	1.378	0.197	0.827	0.394	0.748	2
WEX31250M16Z3	○	1.250	0.669	M16	2.480	1.575	0.197	0.906	0.394	0.945	3
WEX31500M16Z4	○	1.500	0.669	M16	2.480	1.575	0.197	0.906	0.394	0.945	4

○ Available 1st Quarter 2017

Arbor



★ Worldwide Warehouse Item Inserts are not included

WEX2000 Inserts

Insert	Material					Dimensions (Inches)				
	P	K	M	S	N	L	W	T	R	Facet Width
AXMT123504PEERG	●	●	●	●	●	.472	.260	.138	.016	.061
AXMT123504PEERH	●	●	●	●	●	.472	.260	.138	.016	.061
AXMT123508PEERG	●	●	●	●	●	.472	.260	.138	.031	.061
AXMT123508PEERH	●	●	●	●	●	.472	.260	.138	.031	.061
AXMT123512PEERG	●	●	●	●	●	.472	.260	.138	.047	.061
AXMT123512PEERH	●	●	●	●	●	.472	.260	.138	.047	.061
AXMT123504PEERE				●	●	.472	.260	.138	.016	.061
AXMT123508PEERE				●	●	.472	.260	.138	.031	.061
AXMT123508PEEREH				●	●	.472	.260	.138	.031	.061
AXMT123512PEERE				●	●	.472	.260	.138	.047	.061
AXMT123516PEERE				●	●	.472	.260	.138	.063	.061
AXMT123524PEERE				●	●	.472	.260	.138	.094	.061
AXMT123532PEERE				●	●	.472	.260	.138	.126	.061
AXET123502PEFRS					●	.472	.260	.138	.008	.061
AXET123504PEFRS					●	.472	.260	.138	.016	.061
AXET123508PEFRS					●	.472	.260	.138	.031	.061

WEX 2016 M08 Z2

(1) Cutter Series (2) Insert Size (3) Diameter (4) Mounting Screw (5) No. of Flutes

Hardware (WEX2000M)

Spanner	Screw	Recommended Tightening Torque (N-m)	Applicable Endmill
TRDR08IP	BFTX0305IP	2.0	WEX2016M, WEX2018M
	BFTX0306IP	2.0	WEX2020M ~ WEX2040M

Anti-seizure cream SUMI-P included in the package

WEX3000 Inserts

Insert	Material					Dimensions (Inches)				
	P	K	M	S	N	L	W	T	R	Facet Width
AXMT170504PEERG	●	●	●	●	●	.689	.402	.219	.016	.118
AXMT170508PEERG	●	●	●	●	●	.689	.402	.219	.031	.118
AXMT170508PEERH	●	●	●	●	●	.689	.402	.219	.031	.118
AXMT170508PEERL	●	●	●	●	●	.689	.402	.219	.031	.118
AXMT170512PEERG	●	●	●	●	●	.689	.402	.219	.047	.118
AXMT170512PEERH	●	●	●	●	●	.689	.402	.219	.047	.118
AXMT170516PEERG	●	●	●	●	●	.689	.402	.219	.063	.118
AXMT170520PEERG	●	●	●	●	●	.689	.402	.219	.079	.118
AXMT170530PEERG	●	●	●	●	●	.689	.402	.219	.118	.118
AXMT170532PEERG	●	●	●	●	●	.689	.402	.219	.126	.118
AXMT170504PEERE				●	●	.689	.402	.219	.016	.118
AXMT170508PEERE				●	●	.689	.402	.219	.031	.118
AXMT170508PEEREH				●	●	.689	.402	.219	.031	.118
AXMT170512PEERE				●	●	.689	.402	.219	.047	.118
AXMT170516PEERE				●	●	.689	.402	.219	.063	.118
AXMT170520PEERE				●	●	.689	.402	.219	.079	.118
AXMT170524PEERE				●	●	.689	.402	.219	.094	.118
AXMT170530PEERE				●	●	.689	.402	.219	.118	.118
AXMT170531PEERE				●	●	.689	.402	.219	.122	.118
AXMT170548PEERE				●	●	.689	.402	.219	.189	.118
AXMT170563PEERE				●	●	.689	.402	.219	.248	.118
AXET170502PEFRS					●	.689	.402	.219	.008	.118
AXET170504PEFRS					●	.689	.402	.219	.016	.118
AXET170508PEFRS					●	.689	.402	.219	.031	.118

Hardware (WEX3000M)

Spanner	Screw	Recommended Tightening Torque (N-m)	Applicable Endmill
TRDR15IP	BFTX0407IP	3.0	WEX3025M ~ WEX3030M
	BFTX0409IP	3.0	WEX3032M ~ WEX3040M



Rake Angle	Radial	-5°
	Axial	10°

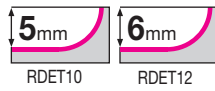

P	M	K	N	N	S	H
Steel	Stainless Steel	Cast Iron	Non-ferrous Metals	Aluminum	Exotic Alloy	Hardened Steel

MODULAR- INCH & METRIC

RSX Series

RSX

Milling for steel, stainless steel, cast iron, and non-ferrous alloys

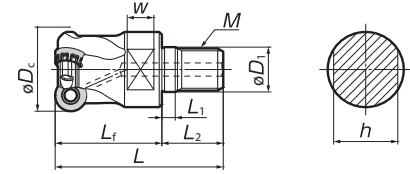

Modular Head Course Pitch - INCH										Insert: RDE10	
Catalog Number	Stock	Dimensions (in)								No. of Teeth	
		ϕD_c	ϕD_1	M	L	L_f	L_1	L_2	W		h
RSXF31000M12Z3	○	1.000	0.492	M12	2.205	1.378	0.197	0.827	0.394	0.748	3
RSXF31250M16Z4	○	1.250	0.669	M16	2.480	1.575	0.197	0.906	0.394	0.945	4

Modular Head Fine Pitch - INCH										Insert: RDE12	
Catalog Number	Stock	Dimensions (in)								No. of Teeth	
		ϕD_c	ϕD_1	M	L	L_f	L_1	L_2	W		h
RSXF41250M16Z3	○	1.250	0.669	M16	2.480	1.575	0.197	0.906	0.394	0.945	3
RSXF41500M16Z4	○	1.500	0.669	M16	2.480	1.575	0.197	0.906	0.394	0.945	4

○ Available 1st Quarter 2017

Modular Head Course Pitch - METRIC										Insert: RDE10		
Catalog Number	Stock	Dimensions (mm)								No. of Teeth	Weight (kg)	
		ϕD_c	ϕD_1	M	L	L_f	L_1	L_2	W			h
RSX10025M12Z2	★	25	12.5	M12	56	35	5	21	10	19	2	0.1
RSX10032M16Z3	★	32	17.0	M16	63	40	5	23	10	24	3	0.2
RSX12032M16Z2	★	32	17.0	M16	63	40	5	23	10	24	2	0.2
RSX12040M16Z3	★	40	17.0	M16	63	40	5	23	10	24	3	0.3

Modular Head Fine Pitch - METRIC										Insert: RDE12		
Catalog Number	Stock	Dimensions (mm)								No. of Teeth	Weight (kg)	
		ϕD_c	ϕD_1	M	L	L_f	L_1	L_2	W			h
RSXF10025M12Z3	★	25	12.5	M12	56	35	5	21	10	19	3	0.1
RSXF10032M16Z4	★	32	17.0	M16	63	40	5	23	10	24	4	0.2
RSXF12032M16Z3	★	30	17.0	M16	63	40	5	23	10	24	3	0.2
RSXF12040M16Z4	★	32	17.0	M16	63	40	5	23	10	24	4	0.3

★ Worldwide Warehouse Item Inserts are not included.

Insert & Parts Information



Inserts	P	K	M	S	Dimensions		
	ACP200	ACK300	ACM100	ACM200	ACP300	I.C.	Thickness
RDE10T3M0EN-G	●	●	●	●	●	0.394	0.156
RDE10T3M0EN-H	●	●	●	●	●	0.472	0.187
RDE1204M0EN-G	●	●	●	●	●	0.629	0.256
RDE1204M0EN-H	●	●	●	●	●		
RDE1606M0EN-G	●	●	●	●	●		
RDE1606M0EN-H	●	●	●	●	●		

●: U.S.A. Stock Item

Arbor



Modular Head Identification Details

RSX F 10 025 M12 Z3

(1) Cutter Series (2) Pitch Type (3) Insert Size (4) Diameter (5) Mounting Screw (6) No. of Teeth

Hardware			
Spanner	Screw	Recommended Tightening Torque (N x m)	Applicable Head
TRDR15IP	BFTX03584IP BFTX0409IP	3.0 3.0	RSX10000M RSX12000M



MSX Series

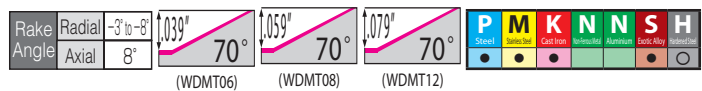

MSX Ultra-high speed, high efficiency machining endmill

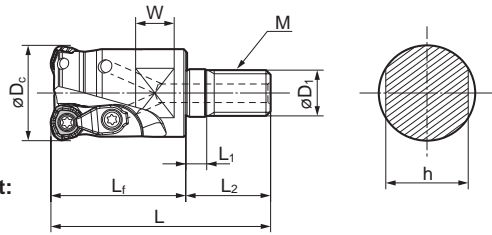

Applicable Insert:
WDMT06

Applicable Insert:
WDMT08

Applicable Insert:
WDMT12

Modular Head - INCH		Insert: WDMT06 Type									
Catalog Number	Stock	Dimensions (in.)									No. of Teeth
		øD _c	øD ₁	M	L	L _f	L ₁	L ₂	W	h	
MSX20750M10Z3	○	0.750	0.413	M10	1.929	1.181	0.197	0.748	0.315	0.591	3
MSX21000M12Z3	○	1.000	0.492	M12	2.205	1.378	0.197	0.827	0.394	0.748	3

Modular Head - INCH		Insert: WDMT08 Type									
Catalog Number	Stock	Dimensions (in.)									No. of Teeth
		øD _c	øD ₁	M	L	L _f	L ₁	L ₂	W	h	
MSX31000M12Z2	○	1.000	0.492	M12	2.205	1.378	0.197	0.827	0.394	0.748	2
MSX31250M16Z3	○	1.250	0.669	M16	2.480	1.575	0.197	0.906	0.394	0.945	3

Modular Head - METRIC		Insert: WDMT06 Type									
Catalog Number	Stock	Dimensions (in.)									No. of Teeth
		øD _c	øD ₁	M	L	L _f	L ₁	L ₂	W	h	
MSX 06016M08Z2	★	16	8.5	M8	42	25	5	17	8	13	2
MSX 06018M08Z2	★	18	8.5	M8	42	25	5	17	8	13	2
MSX 06020M10Z3	★	20	10.5	M10	49	30	5	19	8	15	3
MSX 06022M10Z3	★	22	10.5	M10	49	30	5	19	8	15	3
MSX 06025M12Z3	★	25	12.5	M12	56	35	5	21	10	19	3

Modular Head - METRIC		Insert: WDMT08 Type									
Catalog Number	Stock	Dimensions (in.)									No. of Teeth
		øD _c	øD ₁	M	L	L _f	L ₁	L ₂	W	h	
MSX 08025M12Z2	★	25	12.5	M12	56	35	5	21	10	19	2
MSX 08028M12Z2	★	28	12.5	M12	56	35	5	21	10	19	2
MSX 08030M16Z3	★	30	17.0	M16	63	40	5	23	10	24	3
MSX 08032M16Z3	★	32	17.0	M16	63	40	5	23	10	24	3
MSX 08035M16Z3	★	35	17.0	M16	63	40	5	23	10	24	3

Modular Head - METRIC		Insert: WDMT12 Type									
Catalog Number	Stock	Dimensions (in.)									No. of Teeth
		øD _c	øD ₁	M	L	L _f	L ₁	L ₂	W	h	
MSX 12032M16Z2	★	32	17.0	M16	63	40	5	23	10	24	2
MSX 12035M16Z2	★	35	17.0	M16	63	40	5	23	10	24	2
MSX 12040M16Z3	★	40	17.0	M16	63	40	5	23	10	24	3

★ Worldwide Warehouse Item

Arbor



○ Available 1st Quarter 2017

Insert	Material					Insert Dimensions (in)			Max Depth of Cut (In.)
	P	K	M	S	W	R	t		
WDMT0603ZDTR	●	●	●	●	.250	.0591	.1181	.039	
WDMT0804ZDTR	●	●	●	●	.335	.0787	.1575	.059	
WDMT1205ZDTR	●	●	●	●	.472	.0787	.1969	.079	
WDMT1406ZDTR	●	●	●	●	.551	.0787	.2362	.098	
WDMT0603ZDTR-H	●	●	●	●	.250	.0591	.1181	.039	
WDMT0804ZDTR-H	●	●	●	●	.335	.0787	.1575	.059	
WDMT1205ZDTR-H	●	●	●	●	.472	.0787	.1969	.079	
WDMT1406ZDTR-H	●	●	●	●	.551	.0787	.2362	.098	

● USA stocked item

Hardware

Wrench	Screws	Clamp	C ring	Clamp Screw	Recommended Tightening Torque (N*m)	Applicable Head
TRDR08IP	BFTX02505IP	-	-	-	1.5	MSX06000M
	BFTX0306IP	CCH3.5	CR3	BFTX03510IP08	2.0	MSX08000M
TRDR15IP	BFTX0409IP	CCH3.5	CR3	BFTX03510IP15	3.0	MSX12000M

Modular Head Identification

MSX 06 016 M08 Z2

(1) Cutter Series (2) Insert Size (3) Diameter (4) Mounting Screw (5) No. of Flutes

Performance

Tool: MSX12032EM Insert: WDMT1205ZDTR-ACP200 *Actual measurement for an integrated endmill type.

Helical Boring	Contour Machining
Work material : 1015 Cutting Conditions : v _c =558 SFM n=1,700min ⁻¹ f _z =.059 IPT D.O.C.=.032" Radial=.276" OH=5.315"	Work material : 4137 Cutting Conditions : v _c =492 SFM n=1,500min ⁻¹ f _z =.039 IPT D.O.C.=.032" Radial=.354"~.472" OH=5.315"
Results: Some chattering but cut edge looks good and provides good chip control. 20% better efficiency than competitor A. (Chipping found on Comp A's tool)	Results: 50% faster feed rate than competitor B. (Comp B's tool failed to perform at this rate)



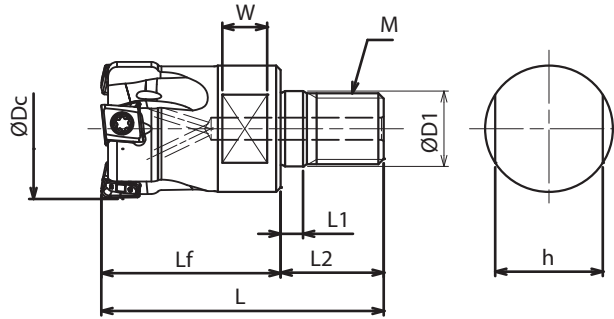

Modular Head - INCH		Insert: LNEXT8 Type									
Catalog Number	Stock	Dimensions (in.)									No. of Teeth
		ØD _c	ØD ₁	M	L	L _f	L ₁	L ₂	W	h	
TSXF30750M10Z3	○	0.750	0.413	M10	1.929	1.181	0.197	0.748	0.315	0.591	3
TSXF31000M12Z4	○	1.000	0.492	M12	2.205	1.378	0.197	0.827	0.394	0.748	4
TSXF31250M16Z5	○	1.250	0.669	M16	2.480	1.575	0.197	0.906	0.394	0.945	5
TSXF31500M16Z6	○	1.500	0.669	M16	2.480	1.575	0.197	0.906	0.394	0.945	6

Modular Head - INCH		Insert: LNEXT13 Type									
Catalog Number	Stock	Dimensions (in.)									No. of Teeth
		ØD _c	ØD ₁	M	L	L _f	L ₁	L ₂	W	h	
TSX41000M12Z2	○	1.000	0.492	M12	2.205	1.378	0.197	0.827	0.394	0.748	2
TSX41250M16Z3	○	1.250	0.669	M16	2.480	1.575	0.197	0.906	0.394	0.945	3
TSX41500M16Z4	○	1.500	0.669	M16	2.480	1.575	0.197	0.906	0.394	0.945	4

○ Available 1st Quarter 2017

Inserts	P					K		M		S		R
	ACP100	ACP200	ACP300	ACK200	ACK300	ACM200	ACM300	ACM300	ACM300	ACM300		
LNEX080404PNER-L	○	○	○	○	○	○	○	○	○	○	.016	
LNEX080404PNER-G	○	○	○	○	○	○	○	○	○	○	.016	
LNEX080408PNER-L	○	○	○	○	○	○	○	○	○	○	.031	
LNEX080408PNER-G	○	○	○	○	○	○	○	○	○	○	.031	
LNEX080412PNER-G	○	○	○	○	○	○	○	○	○	○	.047	
LNEX080416PNER-G	○	○	○	○	○	○	○	○	○	○	.063	
LNEX130604PNER-L	○	○	○	○	○	○	○	○	○	○	.016	
LNEX130604PNER-G	○	○	○	○	○	○	○	○	○	○	.016	
LNEX130608PNER-L	○	○	○	○	○	○	○	○	○	○	.031	
LNEX130608PNER-G	○	○	○	○	○	○	○	○	○	○	.031	
LNEX130608PNER-H	○	○	○	○	○	○	○	○	○	○	.031	
LNEX130616PNER-G	○	○	○	○	○	○	○	○	○	○	.063	
LNEX130616PNER-H	○	○	○	○	○	○	○	○	○	○	.063	
LNEX130624PNER-G	○	○	○	○	○	○	○	○	○	○	.094	
LNEX130624PNER-H	○	○	○	○	○	○	○	○	○	○	.094	
LNEX130632PNER-G	○	○	○	○	○	○	○	○	○	○	.126	
LNEX130632PNER-H	○	○	○	○	○	○	○	○	○	○	.126	

○ Available 1st Quarter 2017

LNEX08
Max. DOC 8mm (.315")

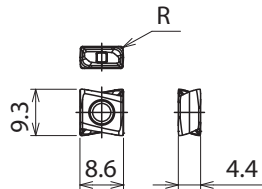

LNEX13
Max. DOC 12 mm (.473")

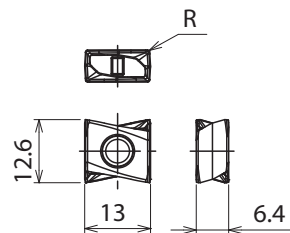

Arbor



Modular Head Identification Details

TSX F 3 0750 M12 Z3

(1) Cutter Series	(2) Pitch Type	(3) Insert Size	(4) Diameter	(5) Mounting Screw	(6) No. of Teeth
		3:08			
		4:13			

Hardware

Insert Size	Catalog Number	Insert Screw	Wrench	Recommended Tightening Torque
TSX3000 (LNEX08)	TSX□30625□~TSX□30750□	BFTX0306IP	TRDR08IP	2.0Nm
	TSX□31000□~TSX□32500□	BFTX0308IP		
TSX4000 (LNEX13)	TSX□41000□~TSX□44000□	BFTX03510IP	TRDR15IP	3.0Nm



Indexable Milling
Shoulder Milling
Face Milling
High Feed Milling
Multi-purpose
Modular Tooling
UFO & SumiMill
Discontinued



SUMITOMO

CARBIDE - CBN - DIAMOND

1-800-950-5202

www.sumicarbide.com

PCD & PCBN MILLING

Pages 401-412



PCBN & PCD
Milling

PCD CUTTERS	PAGES
HF Shell Mills	402-406
RF Shell Mills	407
SRF Shell Mills	408
CBN CUTTERS	PAGES
RM Shell Mills	409-410
FM Shell Mills	411
BRC Endmills & Shell Mills.....	412



General Features

The HF Type high-efficiency aluminum cutter with **air/ coolant through system** employs a unique insert design to eliminate burrs and to achieve superior surface finishes.

Part Material

- Aluminum and aluminum alloys
- Other non-ferrous metal
- Not suited for cast iron or steel**

Characteristics

- Achieves high-efficiency milling due to its high density design (3 teeth per inch)

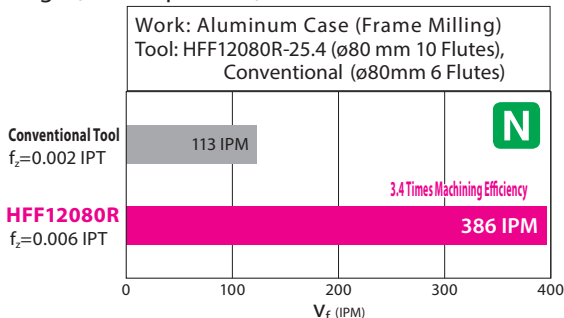
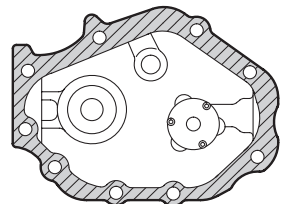

Table 1

Cutter (in.)	s max (RPM)	V_c Max (SFM)	f_z (IPT)	Max No. of Edges	Feed (IPM)
2.500	13,000	8,500	to 0.008	6	to 624
3.000	12,000	9,400	to 0.008	9	to 864
4.000	9,500	9,900	to 0.008	12	to 912
5.000	7,500	9,800	to 0.008	15	to 900
6.000	6,000	9,400	to 0.008	18	to 864

PCBN & PCD Milling



- The wedge clamp's locating mechanism ensures safety and ease of use

The shape and structure of the clamp prevents dislocation by centrifugal force

Ensure that the maximum allowable spindle speed (s max) specified for each cutter diameter is not exceeded. Failing to do so is very dangerous (*See table 1)

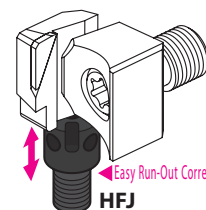
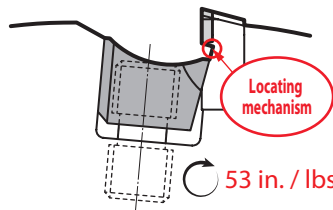

- Preset height adjuster
- Tighten wedge clamp
- Fasten height adjustment screw

- Achieves a run-out precision of $5\mu\text{m}$ (0.0002") or less by employing an easy fine-tuning mechanism
- Reduces burrs by using a double-chamfered cutting edge

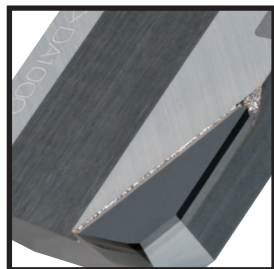

Drastically reduces burrs by preventing the plastic deformation that causes burrs.

Work Material: A6061 Blanks
Cutting Conditions: $v_c=9,800$ SFM,
 $f_z=0.004$ in./t,
 $a_p=0.02$ in., Dry

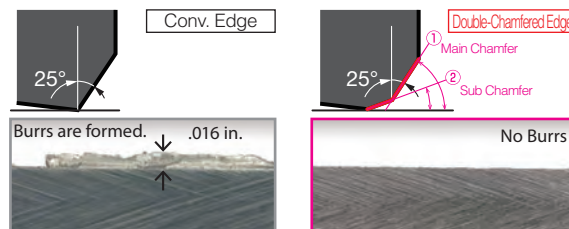

- Reduces tooling costs by drastically increasing the insert regrinding amount (to 0.07 in.)

Assuming the amount of regrinding to be 0.007 in., an edge can be used up to 10 times.

(* Given the condition of normal wear with a_p of .055 in. or less)

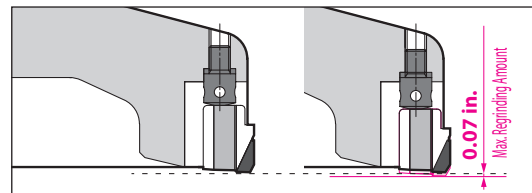

The regrinding amount has been drastically increased compared to conventional screw-lock types.



Internal coolant holes

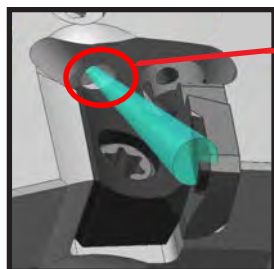

- Improved chip evacuation with internal coolant (HFFH, HFMH, HF-BBT30 Series)
- Prevent chip packing and lengthen tool life by using internal coolant



SUMIDIA Cutter for High-Efficiency Cutting of Aluminum and Non-Ferrous Metals

SUMIBORON MILLS HF Series

Edge Selection Guide

Material	N				
Type	L	G	GX	H	W
Cutting Edge Insert Figure					
Characteristics	Low Cutting Force	Standard	Long Edge	High Strength	
Application	Reduction of Back Force	General Purpose	Roughing	Emphasis on Fracture Resistance	Wiper
*Blank Length	6.0mm	6.0mm	9.0mm	6.0mm	
Max D.O.C.	3.0mm	3.0mm	3.0mm	3.0mm	—

*Blank Length
9.0mm only for GX Type

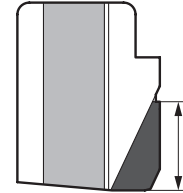

Guideline for Edge Selection

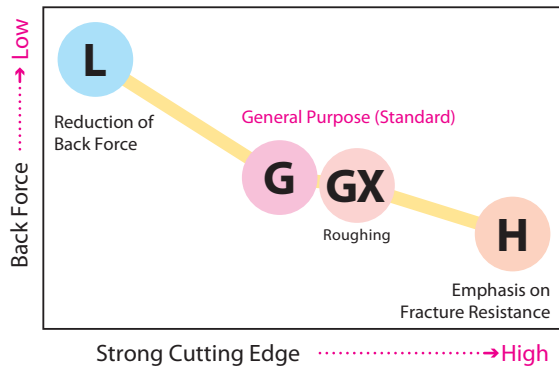

Amount of Wiper Insert Gap

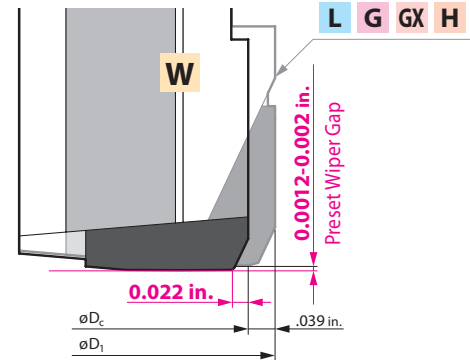

Parts Assembly of HF Series

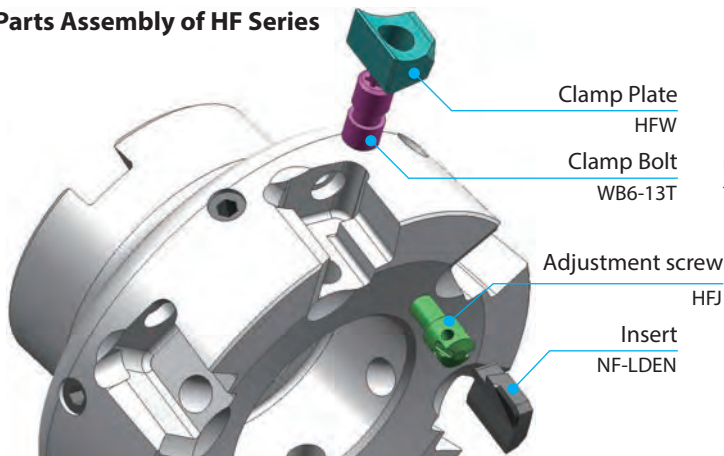

Insert Removal Direction

Loosen the screw by one turn before removing the insert.



If the insert is forcibly removed in the wrong direction, damage may occur.

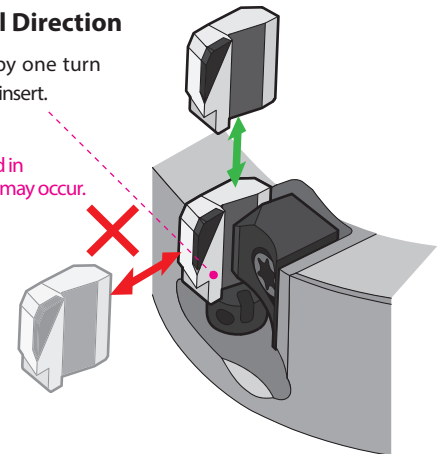

Application Examples

● Work : Crankcase Cover		HFFH
Work Material : Aluminium Alloy	Tool	HFFH12100R-25.4
	Insert	NF-LDEN12T3ZDTR-H
	Grade	DA1000
	No. of Teeth	12
	V_c (SFM)	6,181
	n (RPM)	6000
	V_f (IPM)	141"
	f_z (in./T)	.002"
	a_p (in.)	.008"
	Coolant	Wet
	Results	With through coolant, Tool Life x 2 vs. flood coolant Achieved 3600 finished parts Excellent surface finish!

● Work : Engine Component		HFFH
Work Material : Aluminium Alloy	Tool	HFFH12125R-31.75
	Insert	NF-LDEN12T3ZDTR-G
	Grade	DA1000
	No. of Teeth	15
	V_c (SFM)	9,662
	n (RPM)	7,500
	V_f (IPM)	266"
	f_z (in./T)	.0024"
	a_p (in.)	.00788"
	Coolant	Wet
	Results	With through coolant, Tool Life x 1.7 vs. flood coolant Achieved 17,000 finished parts Great chip control!



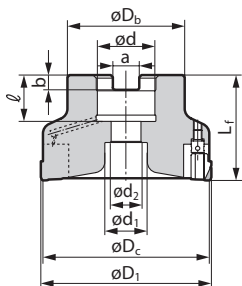

Rake Angle	Radial	+4°
	Axial	+10°

1.12" 90°



PCBN & PCD Milling

HFMH Body (Standard Pitch) - INCH

Cat. No.	Stock	Dimensions (in.)										Coolant Hole	Coolant Bolt	No. of Teeth	Weight (lbs)
		ϕD_c	ϕD_1	ϕD_b	L_f	ϕd	a	b	ℓ	ϕd_1	ϕd_2				
HFMH42500R	●	2.500	2.579	1.970	2.000	1.000	0.375	0.220	1.020	0.797	0.531	YES	BFXH1/2X1 1/4	6	1.76
HFMH43000R	●	3.000	3.079	1.970	2.000	1.000	0.375	0.220	1.020	0.797	0.531	YES	BFXH1/2X1 1/4	6	2.42
HFMH44000R	●	4.000	4.079	2.756	2.000	1.500	0.625	0.380	1.457	2.126	0.781	YES	BFXH3/4X2	8	3.96
HFMH45000R	●	5.000	5.079	3.150	2.000	1.500	0.625	0.380	1.457	2.126	0.781	YES	BFXH3/4X2	10	6.17
HFMH46000R	●	6.000	6.079	3.740	2.374	1.500	0.625	0.380	1.457	2.756	0.781	YES	BFXH3/4X2	12	9.50

HFFH Body (Fine Pitch) - INCH

Cat. No.	Stock	Dimensions (in.)										Coolant Hole	Coolant Bolt	No. of Teeth	Weight (lbs)
		ϕD_c	ϕD_1	ϕD_b	L_f	ϕd	a	b	ℓ	ϕd_1	ϕd_2				
HFFH43000R	●	3.000	3.079	1.970	2.000	1.000	0.375	0.220	1.020	0.797	0.531	YES	BFXH1/2X1 1/4	9	2.20
HFFH44000R	●	4.000	4.079	2.756	2.000	1.500	0.625	0.380	1.457	2.126	0.781	YES	BFXH3/4X2	12	3.75
HFFH45000R	●	5.000	5.079	3.150	2.000	1.500	0.625	0.380	1.457	2.126	0.781	YES	BFXH3/4X2	15	5.95
HFFH46000R	●	6.000	6.079	3.740	2.374	1.500	0.625	0.380	1.457	2.756	0.781	YES	BFXH3/4X2	18	9.30

Inserts

Grade		PCD				
Application	High Speed/Light	N	N Non-Ferrous Metal			
	General Purpose	N				
	Roughing	N				
Cat. No.		DA1000	Edge Length	Unique Wiper Edge	Application	Fig
NF-LDEN 12T3ZDFR-L		●	6	Straight	Low Cutting Force	4
12T3ZDFR-G		●	6	Arc	General Purpose	4
12T3ZDTR-H		●	6	Arc	Strong Edge	4
12T3ZDFR-R0.4		●	6	Arc	Radius Edge	7
12T3ZDFR-GX		●	9	Arc	Long Edge	5
12T3ZDFR-W		●	-	Arc	Wiper	6

Fig 4

Fig 5

Fig 6

Fig 7

● : U.S.A. Stock Standard

Parts

Clamp Plate	Clamp Bolt	Adjustment screw	Adjusting Wrench	Wrench	Assembling Wrench
HFV	WB6-13T 53.0 in./lbs	HFJ	TTX20	RFT	HFVT (Sold Separately)

Recommended Tightening Torque (in./lbs)

Recommended Cutting Conditions

Si content of 12.6% or less.

ISO	Work Material	Hardness	Cutting Speed v_c (SFM) Min.- Optimum -Max.	Feed Rate f_z (in./t) Min.- Optimum -Max.	Grade
N	Aluminium Alloy	-	6550- 8200 -9850	0.002-0.005-0.008	DA1000

*see table 1 for Max SFM by cutter diameter

Si content of over 12.6%

N	Aluminium Alloy	-	1300-1950-2600	0.002-0.005-0.008	DA1000
---	-----------------	---	----------------	-------------------	--------

Note The cutting conditions above are a guide. Actual conditions will need to be adjusted according to machine rigidity, work clamp rigidity, cutting depth, and other factors.

Identification Details

HF M H 4 2500 R

(1) Cutter Series (2) M: Course Pitch (3) Coolant (4) Insert Size (5) Cutter Size (6) Direction
 F: Fine Pitch



SUMIDIA Cutter for High-Efficiency Cutting of Aluminum and Non-Ferrous Metals

SUMIBORON MILLS

HF Series

Rake Angle	Radial	+4°
	Axial	+10°

3mm 90°

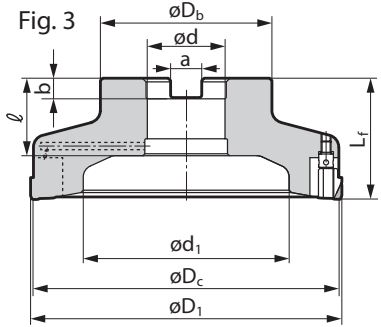
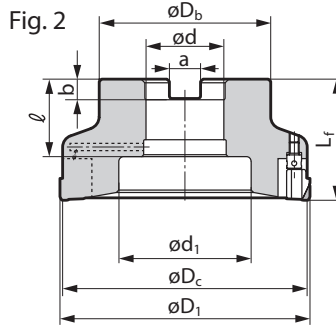
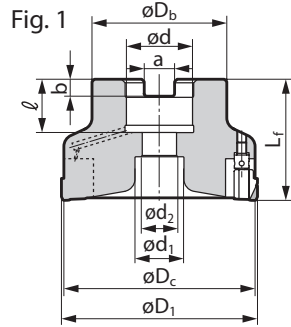

HFM Body (Standard Pitch) - METRIC

Cat. No.	Stock	Dimensions (mm)										Coolant Hole	Coolant Bolt	No. of Teeth	Weight (lbs)	Fig.
		ϕD_c	ϕD_1	ϕD_b	L_f	ϕd	a	b	ℓ	ϕd_1	ϕd_2					
HFM12080RS-22	★	80	82	50	40	22	10.4	6.3	20	18	11	-	-	6	2.20	1
HFM12080RS-27	★	80	82	55	50	27	12.4	7	22	20	14	-	-	6	2.64	1
HFM12100RS-32	★	100	102	70	50	32	14.4	8	32	54	-	-	-	8	3.75	2
HFM12125RS-32	★	125	127	70	50	32	14.4	8	32	84	-	-	-	10	4.85	3
HFM12125RS-40	★	125	127	90	63	40	16.4	9	35	84	-	-	-	10	6.17	3
HFM12080R-25.4	★	80	82	50	50	25.40	9.5	6	30	35	-	-	-	6	2.20	2
HFM12100R-25.4	★	100	102	50	50	25.40	9.5	6	30	54	-	-	-	8	3.31	2
HFM12100R-31.75	★	100	102	70	50	31.75	12.7	8	32	54	-	-	-	8	3.75	2
HFM12125R-25.4	★	125	127	50	50	25.40	9.5	6	30	84	-	-	-	10	4.40	3
HFM12125R-31.75	★	125	127	70	50	31.75	12.7	8	32	84	-	-	-	10	4.85	3
HFM12125R-38.1	★	125	127	80	63	38.10	15.9	10	36	84	-	-	-	10	5.51	3

* Sold Separately

HFF / HFFH Body (Fine Pitch) - METRIC

Cat. No.	Stock	Dimensions (mm)										Coolant Hole	Coolant Bolt	No. of Teeth	Weight (lbs)	Fig.
		ϕD_c	ϕD_1	ϕD_b	L_f	ϕd	a	b	ℓ	ϕd_1	ϕd_2					
HFF12080RS-22	★	80	82	50	40	22	10.4	6.3	20	18	11	-	-	10	2.20	1
HFF12080RS-27	★	80	82	55	50	27	12.4	7	22	20	14	-	-	10	2.64	1
HFF12100RS-32	★	100	102	70	50	32	14.4	8	32	54	-	-	-	12	3.75	2
HFF12125RS-32	★	125	127	70	50	32	14.4	8	32	84	-	-	-	15	4.85	3
HFF12125RS-40	★	125	127	90	63	40	16.4	9	35	84	-	-	-	15	6.17	3
HFF12080R-25.4	★	80	82	50	50	25.40	9.5	6.3	30	35	-	-	-	10	2.20	2
HFF12100R-25.4	★	100	102	50	50	25.40	9.5	6	30	54	-	-	-	12	3.30	2
HFF12100R-31.75	★	100	102	70	50	31.75	12.7	8	32	54	-	-	-	12	3.75	2
HFF12125R-25.4	★	125	127	50	50	25.40	9.5	6	30	84	-	-	-	15	4.41	3
HFF12125R-31.75	★	125	127	70	50	31.75	12.7	8	32	84	-	-	-	15	4.85	3
HFF12125R-38.1	★	125	127	80	63	38.10	15.9	10	36	84	-	-	-	15	5.51	3
HFFH12080RS-22	★	80	82	50	40	22	10.4	6.3	20	18	11	YES	* BFXH1025-D16	10	2.20	1
HFFH12080RS-27	★	80	82	55	50	27	12.4	7	22	20	14	YES	* BFXH1230-D18	10	2.64	1
HFFH12100RS-32	★	100	102	70	50	32	14.4	8	32	54	-	YES	* BFXH1635-D40	12	3.75	2
HFFH12125RS-32	★	125	127	70	50	32	14.4	8	32	84	-	YES	* BFXH1635-D40	15	4.85	3
HFFH12125RS-40	★	125	127	90	63	40	16.4	9	35	84	-	YES	* BFXH2036-D50	15	6.17	3
HFFH12080R-25.4	●	80	82	50	50	25.40	9.5	6.3	30	35	-	YES	* BFXH1/2-20X1 1/4-D33	10	2.20	2
HFFH12100R-25.4	●	100	102	50	50	25.40	9.5	6	30	54	-	YES	* BFXH1/2-20X1 1/4-D40	12	3.30	2
HFFH12100R-31.75	●	100	102	70	50	31.75	12.7	8	32	54	-	YES	* BFXH5/8-18X1 1/2-D50	12	3.75	2
HFFH12125R-25.4	●	125	127	50	50	25.40	9.5	6	30	84	-	YES	* BFXH1/2-20X1 1/4-D40	15	4.41	3
HFFH12125R-31.75	●	125	127	70	50	31.75	12.7	8	32	84	-	YES	* BFXH5/8-18X1 1/2-D50	15	4.85	3
HFFH12125R-38.1	●	125	127	80	63	38.10	15.9	10	36	84	-	YES	* BFXH3/4X2	15	5.51	3

■ HFM Identification Details

■ HFF Identification Details

■ HFFH Identification Details

HF M 12 080 R S -22

(1) Cutter Series (2) Standard Pitch (3) Insert Size (4) Cutter Size (5) Direction Metric Bore (6) Arbor Size (7)

HF F 12 080 R S -22

(1) Cutter Series (2) Fine Pitch (3) Insert Size (4) Cutter Size (5) Direction Metric Bore (6) Arbor Size (7)

HF FH 12 080 R S -22

(1) Cutter Series (2) Fine Pitch (3) Coolant (4) Insert Size (5) Cutter Size (6) Direction Metric Bore (7) Arbor Size (8)



HF Lineup - Metric

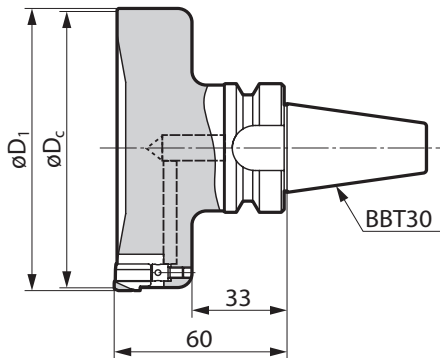
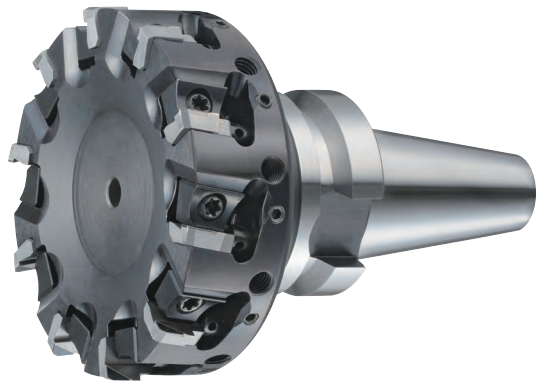

PCBN & PCD
Milling

HF Mono Block Type - Fine Pitch - METRIC

Cat. No.	Stock	Dimensions (mm)		Coolant Hole	No. of Teeth	Weight (lbs)
		ϕD_c	ϕD_1			
HFFH12080R-BBT30	★	80	82	YES	10	3.52
HFFH12100R-BBT30	★	100	102	YES	12	5.29
HFFH12125R-BBT30	★	125	127	YES	15	5.95

■ Inserts

Grade	PCD		
High Speed/Light	N	N Non-Ferrous Metal	
General Purpose	N		
Roughing	N		

Cat. No.	DA1000	Edge Length	Unique Wiper Edge	Application	Fig
NF-LDEN 12T3ZDFR-L	●	6	Straight	Low Cutting Force	4
12T3ZDFR-G	●	6	Arc	General Purpose	4
12T3ZDTR-H	●	6	Arc	Strong Edge	4
12T3ZDFR-R0.4	●	6	Arc	Radius Edge	7
12T3ZDFR-GX	●	9	Arc	Long Edge	5
12T3ZDFR-W	●	-	Arc	Wiper	6

● : U.S.A. Stock Standard

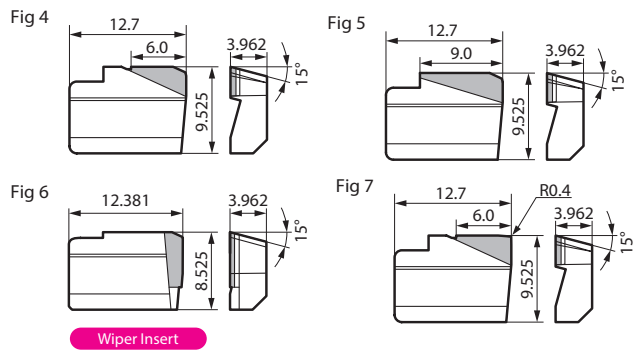

■ Recommended Cutting Conditions

Si content of 12.6% or less.

ISO	Work Material	Hardness	Cutting Speed v_c (m/min) Min.- Optimum -Max.	Feed Rate f_z (mm/t) Min.- Optimum -Max.	Grade
N	Aluminium Alloy	-	2000- 2500 -3000	0.05- 0.13 -0.20	DA1000

Si content of over 12.6% *see table 1 for Max RPM by cutter diameter

N	Aluminium Alloy	-	400- 600 -800	0.05- 0.13 -0.20	DA1000
---	-----------------	---	---------------	------------------	--------

Note The cutting conditions above are a guide. Actual conditions will need to be adjusted according to machine rigidity, work clamp rigidity, cutting depth, and other factors.

■ HFF Identification Details

HF F H 12 080 R -BBT30

(1) Cutter Series (2) Fine Pitch (3) Coolant (4) Insert Size (5) Cutter (6) Direction (7) Arbor Type

Rake Angle	Radial	+4°
	Axial	+10°

3mm 90°



*BIG-PLUS® is a registered trademark of BIG Daishowa Seiki Co., Ltd.

**Mono-block type can be applied for BT30 machining



SUMIDIA Cutter for High Speed Finishing of Non-ferrous Metal

SUMIDIA MILLS RF Series

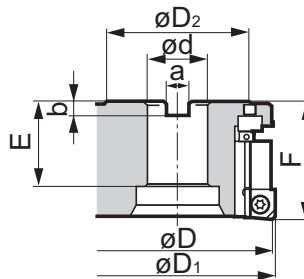
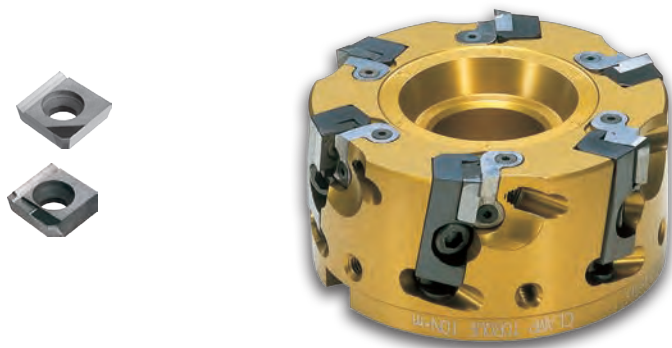

RF Endmill Availability - METRIC										
Sumitomo Cat. No.	Stock	Dimensions (mm)								# of teeth
		ϕD	ϕD_1	ϕD_2	F	ϕd	a	b	E	
RF4080R	★	80.0	82.0	60.0	50.0	25.40	9.5	6.0	30.0	6
RF4100R	★	100.0	102.0	75.0	50.0	31.75	12.7	8.0	38.0	6
RF4125R	★	125.0	127.0	75.0	63.0	38.10	15.9	10.0	38.0	8
RF4160R	★	160.0	162.0	100.0	63.0	50.80	19.0	11.0	38.0	10

NOTES: Cartridges and inserts are sold separately.

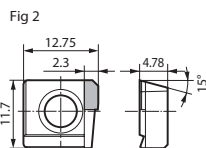
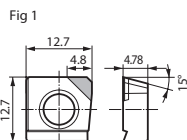



Recommended Running Conditions

Aluminum Alloy			
Si content		Less than 13%	13% and above
Cutting Speed m/min (sfm)	SUMIDIA	2,000~5,000 (6,560~16,404)	400~800 (1,310~2,625)
	Carbide	1,000~2,500 (3,280~8,200)	200~400 (655~1,310)
Feedrate mm/t (ipt)		0.05~0.2 (.002~.008)	0.05~0.2 (.002~.008)
D.O.C. mm (in)		below 3mm (below .118 in.)	below 3mm (below .118 in.)

Inserts			
Description	Sumitomo Catalog No.	SUMIDIA	Figure
		DA1000	
SUMIDIA Insert	NF-SNEW1204ADFR	●	1
Wiper Insert	NF-SNEW1204ADFR-W	●	2

Maximum Allowable Spindle Speed

Cat. No.	s max (RPM)
RF4080R	17,000
RF4100R	15,900
RF4125R	13,500
RF4160R	11,000

Parts			
Description	Sumitomo Catalog No.	Stock	Appearance
Cartridge	RFF	●	
Coolant Through Arbor Bolt	RF-SCB80	●	
	RF-SCB100	●	
	RF-SCB125	●	
	RF-SCB160	●	

NOTES: Cartridges and inserts are sold separately.

Surface Finish		
Conditions	Process: Finishing	V = 16,370 sfm
	Machine: Machining Center	F = 450 ipm
Results	Arbor: HSK63A	f = .005 ipt
	Work Piece: Si10 ~ 12% Al Alloy	d = .020 in.
	Cutter: RF4100R, 6 teeth	d/wiper = .001 in.
	Grade: SUMIDIA DA2200	Dry
		



SUMIDIA MILLS

SRF Series

SUMIDIA Cutter for High Speed Finishing of Non-ferrous Metal

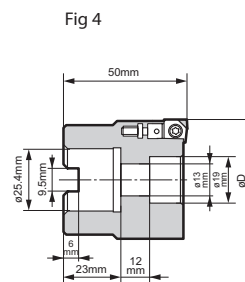
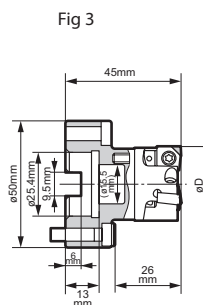
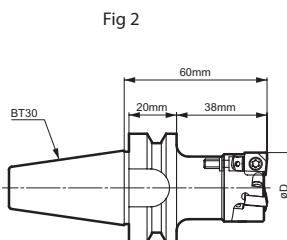
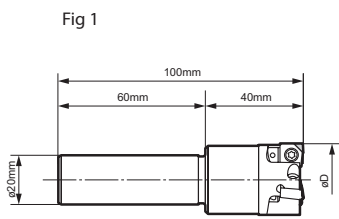

Parts

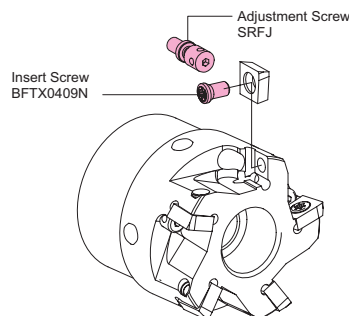

Maximum D.O.C. Guide (SRF50R, 5 teeth)

Below are guidelines for maximum D.O.C. based on internal test results. '●' indicates possible application range. Actual cutting conditions should be set based on actual machine and work piece characteristics.

D.O.C. in (mm)	Feedrate, F: ipm (mm/min)		
	100 (2500)	160 (4000)	200 (5000)
	Feed per tooth, f: ipt (mm/tooth)		
	0.002 (0.05)	0.003 (0.08)	0.004 (0.10)
0.20 (0.5)	●	●	●
0.40 (1.0)	●	●	●
0.60 (1.5)	●	●	●
0.80 (2.0)	●	●	●
0.10 (2.5)	●	●	●
0.12 (3.0)	●	●	●
0.14 (3.5)	●	●	-
0.16 (4.0)	●	-	-
0.18 (4.5)	●	-	-
0.20 (5.0)	●	-	-

Cutting Conditions

Cutter: SRF50R
 Insert: NF-SNEW09T3ADTR (DA2200)
 Arbor: BT30 FMA25.4-45
 Work: A-5052
 Width: 35mm (1.40 in.) at D.O.C. indicated above

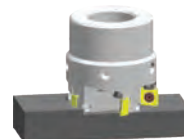

SRF Endmill Availability - METRIC				
Sumitomo Catalog No.	Stock	ØD (mm)	# of Teeth	Fig.
SRF30R-ST	★	30.0	3	1
SRF40R-ST	★	40.0	4	1
SRF30R-BT30	★	30.0	3	2
SRF40R-BT30	★	40.0	4	2
SRF30R	★	30.0	3	3
SRF40R	★	40.0	4	3
SRF50R	★	50.0	5	4
SRF63R	★	63.0	6	4

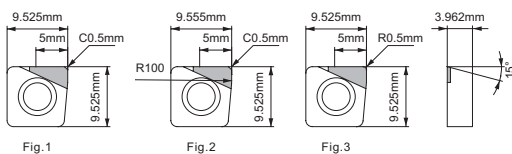

Inserts			
Sumitomo Catalog No.	Cutting Edge	SUMIDIA DA1000	Fig.
NF-SNEW09T3ADTR	Standard	●	1
NF-SNEW09T3ADTR-U	Wiper	●	2
NF-SNEW09T3ADTR-R	Nose Radius	●	3

- Standard inserts and wiper inserts can be used on the same cutter body.
- Standard inserts with nose radius should be used where vibration is present. Wiper inserts are not recommended.
- Inserts can be reground 3 times (up to I.C. diameter of 9.225 mm/0.3632 in.)
- When using reground inserts, it is recommended to reconfirm insert height and cutting diameter with a tool pre-setter.
- Do not mix new and reground inserts OR inserts with different regrind measurements on the same cutter.
- Standard inserts and wiper inserts can be used on the same cutter body.

Arbor for SRF30R & SRF40R

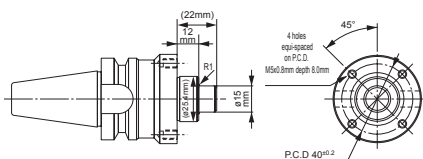

When using the SRF30R or SRF40R cutters, modification to the arbor is required, as shown above.

- 1) Reduce part of the arbor's adaptor shaft from $\phi 25.4$ mm to $\phi 15$ mm.
- 2) Add four tap holes for M5 cap screws.



High Speed SUMIBORON Mill for Cast Iron Roughing

SUMIBORON MILLS RM Series



Features & Benefits

- High speed, high efficiency milling of gray cast iron
- Solid CBN grade BNS800
- Cost effective 8 cornered regrindable insert
- Four corner insert design yields low tooling costs per part
- Simple design for direct insert mounting

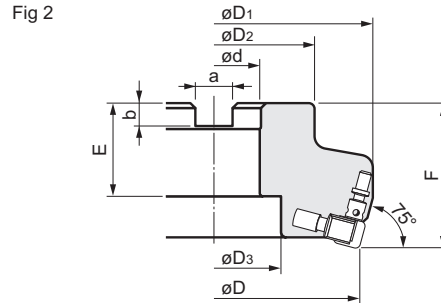
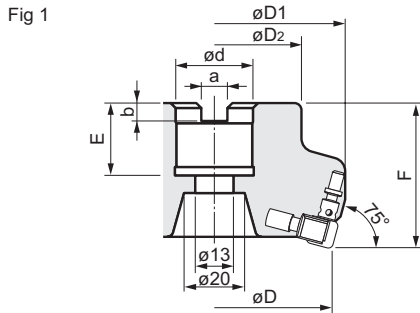

RM Mill Availability - METRIC

Sumitomo Cat. No.	Stock	Dimensions (mm)									No. of Teeth	Fig.
		D	D1	D2	D3	F	d	a	b	E		
RM3080R	•	80	90	60	-	50	25.40	9.5	6	25	6	1
RM3100R	•	100	110	70	46	50	31.75	12.7	8	32	8	2
RM3125R	•	125	135	80	59	63	38.10	15.9	10	38	10	2
RM3160R	•	160	170	100	80	63	50.80	19	11	38	12	2

- USA stocked item

Inserts

Sumitomo Cat. No.	Stock	Grade	Dimensions (Inches)		
			I.C.	T	Cutting Edge
SNG322	•	BNS800	.375	.125	Standard
SNG323	•		.375	.125	Standard
SNEN090308-W	•		.375	.125	Wiper

- NOTES: 1) Do not use a mix of standard and wiper inserts on a single cutter setting.
 2) Do not mix new and reground inserts on a single cutter setting.
 3) Inserts can only be reground once (I.C. must be at least .360")

- USA stocked item

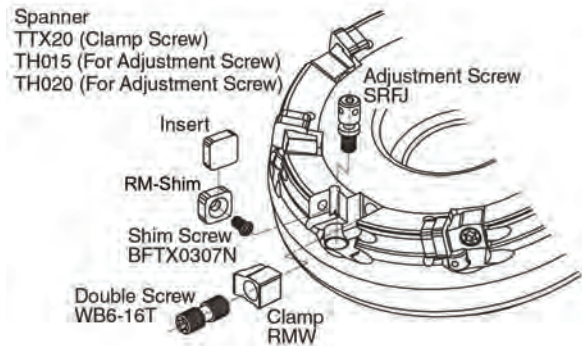

Hardware

Clamp	Double Screw	Shim	Shim Screw	Adjustment Screw
RMW	WB6-16T	RM-SHIM	BFTX0307N	SRFJ

Clamp Wrench	Shim Screw Wrench	Adjustment Screw Wrench	Adjustment Screw Wrench
TTX20	TRX10	TH015	TH020



SUMIBORON MILLS RM Series

High Speed SUMIBORON Mill for Cast Iron Finishing



Features & Benefits

- Removeable cartridges for easy insert run-out management.
- Uses BN700 with high CBN content, offering good wear and fracture resistance.
- Available in both shell and small diameter endmill types.
- High speed machining $V=6500+$ sfm
- Surface roughness $Rz=3.2$ (1Ra)

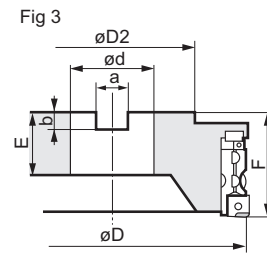
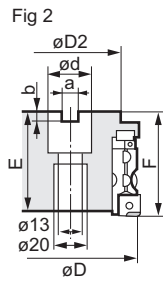
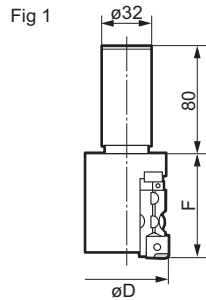

FMU Mill Availability - METRIC

Sumitomo Cat. No.	Stock	Dimensions (mm)									No. of Teeth	Fig.
		D	D1	D2	F	d	a	b	E			
FMU4040ER	★	37	40	-	63	-	-	-	-	2	1	
FMU4050ER	★	47	50	-	63	-	-	-	-	3	1	
FMU4063ER	★	60	63	60	63	25.40	9.5	6	25	4	2	
FMU4080R	★	80	82.8	60	63	25.40	9.5	6	25	6	2	
FMU4100R	★	100	102.8	75	63	31.75	12.7	8	38	8	3	
FMU4125R	★	125	127.8	75	63	38.10	15.9	10	38	10	3	
FMU4160R	★	160	162.8	100	63	50.80	19	11	38	12	3	

★ Worldwide Warehouse item

Hardware

Screw	Screw	Setting Clamp	Double Screw	Wrench	Wrench	Wrench
BH0620*	BTD0609	FMUE	WB5-10	TH040	LH030	LH025

* FMU4040ER/4050ER/4063ER use FMUUE type cartridge

* FMUU/FMUUE use similar screw (BFTX0509N), adjustment screw, (FMUJ) and O-ring (P3)

Hardware

Cartridge	Screw	Adjustment Screw	O-Ring	Wrench	Wrench
FMUU*	BFTX0509N	FMUJ	P3	TRX20	1.8 x 45

* Screw for FMU4040ER/4050ER/4063ER is BH0615

Inserts

			Dimensions (in.)		
Sumitomo Cat. No.	Stock	Grade	I.C.	T	Fig.
SNEW1203ADTR	•	BN7000	.500	.125	1
SNEW1203ADTR-S*	•	BN700	.500	.125	2

• USA stocked item

* Low cutting force insert

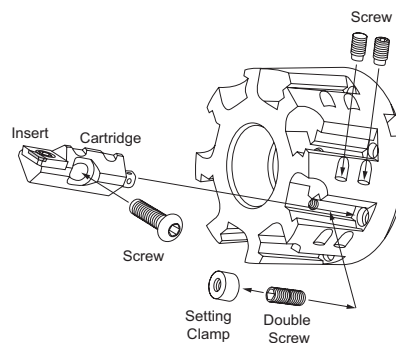

Gauge

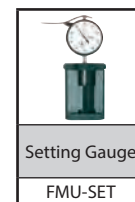

Setting Gauge

FMU-SET

Gauge not included



High Speed SUMIBORON Mill for Cast Iron Finishing

SUMIBORON MILLS FM Series

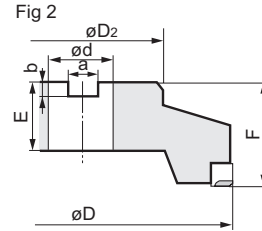
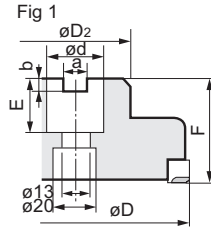
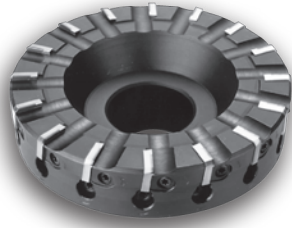

FM Mill Availability - METRIC

Sumitomo Cat. No.	Stock	Dimensions (mm)								No. of Teeth	Fig.
		D	D1	D2	F	d	a	b	E		
FM5080R	★	80	82.8	60	50	24.5	9.5	6	25	6	1
FM5100R	★	100	102.8	75	50	31.75	12.7	8	32	8	2
FM5125R	★	125	127.8	75	63	38.10	15.9	10	38	10	2
FM5160R	★	160	162.8	100	63	50.80	19	11	38	12	2

★ Worldwide Warehouse item

Hardware

						Applicable Cutter
Wedge	Adjustable Seat	Adjustment Screw	Double Screw	Wrench	Wrench	
FMW	FME	FMJ	WB7F-20TL	TT25	1.8 x 45	FM5080R FM5100R- FM5160R

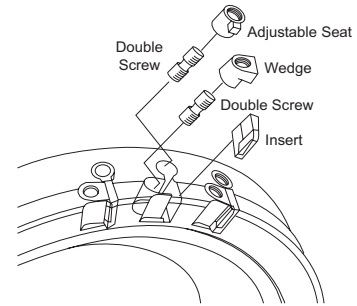

Inserts

	Fig 1 	Fig 2 			
Sumitomo Cat. No.	Stock	Grade	Dimensions (in.)		
			I.C.	T	Fig.
SNEN1504ADTR	•	BN700	.625	.1875	1
SNEN1504ADTR-S*	•		.625	.1875	2

• USA stocked item

* Low cutting force insert



BRC Series

High Speed SUMIBORON Mill

for Hardened Steel & Cast Iron Finishing



Features & Benefits

- High speed, high efficiency milling of hardened mold material.
- Cost effective full-top CBN inserts, multiple corner usage
- Available in both shell and small diameter endmill types.
- Strong clamping with conical insert screw hole design.

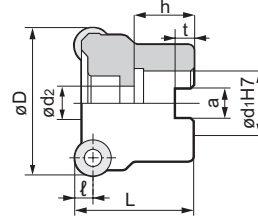

Fig 1

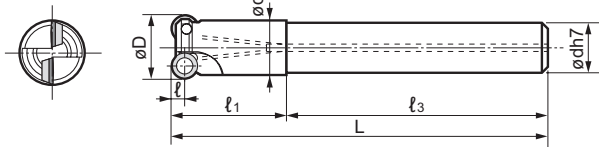

Fig 2

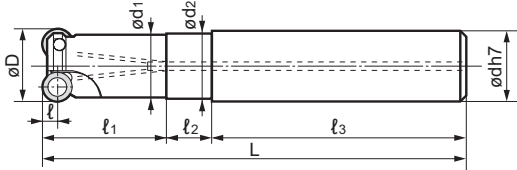
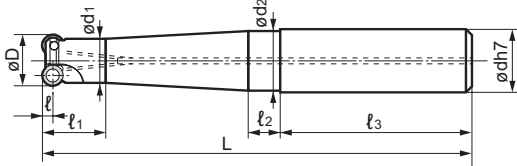

Fig 3



BRC Shell Mill Availability - METRIC

Sumitomo Cat. No.	Stock	Dimensions (mm)								# of teeth	Group
		øD	ød1	ød2	l	L	h	a	t		
BRC10042R	★	42	16	9	5	44	20	8	6	6	C
BRC10052R	★	52	22	11	5	50	30	10	7	7	
BRC12042R	★	42	16	9	6	42	20	8	6	5	D
BRC12052R	★	52	22	11	6	52	30	10	7	5	
BRC12066R	★	66	27	13	6	52	30	12	7	6	

Inserts

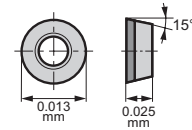

Sumitomo Cat. No.	Stock			Dimensions (in)		Applicable Holder (Grp.)
	BN350	BN7000	BN700	I.C.	T	
RDHX0701M0T	★	★	★	.276	.078	A
RDHX0702M0T	★	★	★	.276	.094	B
RDHX1003M0T	★	★	★	.394	.125	C
RDHX12T3M0T	★	★	★	.472	.156	D

Hardware

Screw	Wrench	Applicable Holder (Grp.)
BFTB025048	TRD07	A
BFTB02505	TRD07	B
BFTB035074	TRD15	C,D

BRC Endmill Availability - METRIC

Sumitomo Cat. No.	Stock	Dimensions (mm)									# of teeth	Fig.	Group
		øD	ød	ød1	ød2	l	l1	l2	l3	L			
BRC071207ES10	★	12	10	11	-	3.5	23	-	52	75	2	1	A
BRC071207ES12	★	12	12	11	11.5	3.5	22	8	45	75	2	2	
BRC071208ES16	★	12	16	11	15.5	3.5	16	8	48	88	2	3	
BRC071210ES16	★	12	16	11	15.5	3.5	16	8	48	108	2	3	
BRC071212ES16	★	12	16	11	15.5	3.5	16	8	48	128	2	3	
BRC071507ES12	★	15	12	12.5	-	3.5	16	-	59	75	3	1	B
BRC071507ES16	★	15	16	12.5	13	3.5	19	11	48	78	3	2	
BRC071508ES16	★	15	16	13.5	15.5	3.5	20	8	48	88	2		
BRC071510ES16	★	15	16	13.5	15.5	3.5	20	8	48	108	2		
BRC071513ES20	★	15	20	13.5	19.5	3.5	22	8	50	130	2		
BRC071515ES20	★	15	20	13.5	19.5	3.5	22	8	50	150	2		
BRC071517ES25	★	15	25	13.5	24.5	3.5	22	8	56	176	2		
BRC102009ES20	★	20	20	17	19.5	5	20	8	50	90	2	3	
BRC102011ES20	★	20	20	17	19.5	5	22	8	50	110	2		
BRC102012ES25	★	20	25	17	24.5	5	24	8	56	136	2	C	
BRC102015ES25	★	20	25	17	24.5	5	24	8	56	156	2		
BRC102017ES25	★	20	25	17	24.5	5	24	8	56	176	2		

Recommended Running Conditions

Conditions	Steel			Cast Iron
	40~45HRC	47~55HRC	58~62HRC	-
	BN7000		BN350	BN7000
V (sfm)	655~2625	490~1310	260~655	980~4920
f (ipt)	.004~.016	.004~.012	.004~.008	.004~.016
d (in)	.020	.020	.020	.020



PCBN & PCD Milling

DISCONTINUED ITEMS

Pages 413-425



INDEXABLE MILLING CUTTERS	PAGES
WGC Face Mills	414-417

UFO Series

UFO Endmills/Shell Mills	418
UFOR Shell Mills	419

sumiMill Series

APG Face Mills	420
DNF Face Mills	420
CHG Face Mills	421
CPG Face Mills	421
DPG Face Mills	422
EHG Face Mills	423
FPG Face Mills	423
WEM/WRM/WFM	424
PWC	425

Indexable Milling

Shoulder Milling

Face Milling

High Feed Milling

Multi-purpose

Modular Tooling

UFO & SumiMill

Discontinued



Features & Benefits

- 45° Lead Angle facilitates feed rate capabilities up to 30% higher than 90° tooling for high performance in face milling applications
- Cutter rake angles and insert design promote efficient cutting action with low horsepower consumption
- Light cutter assembly weight
- Lack of body overhang facilitates machining close to fixturing and/or part details
- Screw on insert design features carbide back up seats for durability, and ease of repair while offering easy set-up and indexing
- Accepts the widest variety of inserts of any Sumitomo milling cutter
- Available in "M" class (molded), "E" class, and several chipbreakers/edge preps and grades for almost any situation



Shank type

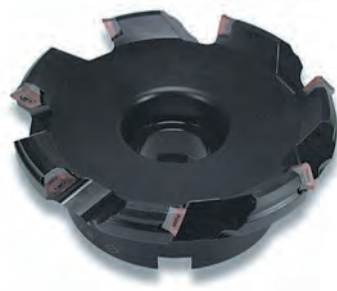

**Shell type
Coarse Pitch**



**Shell type
Fine Pitch**

Chipbreaker Map

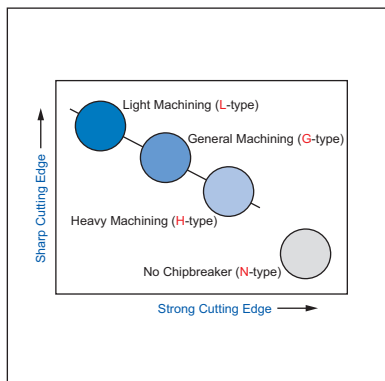

Breaker	L-Type	G-Type	H-Type	N-Type	W-Type
Figure					
Rake Angle θ	25°	20°	15°	0°	
Application	<ul style="list-style-type: none"> • Light cutting • Low force milling of thin work piece • Low burr design 	<ul style="list-style-type: none"> • General purpose to interrupted milling • Main chipbreaker 	<ul style="list-style-type: none"> • Interrupted to Heavy milling • For welded or rolled surfaces 	<ul style="list-style-type: none"> • Very heavy milling 	<ul style="list-style-type: none"> • High precision finish (Wiper edge)



Indexable Milling
 Shoulder Milling
 Face Milling
 High Feed Milling
 Multi-purpose
 Modular Tooling
 UFO & SumiMill
 Discontinued

Inch WGC4000

Applicable Insert:
SEET, SEMT,
SECW, XEEW

Inch WGC/F4000

Applicable Insert:
SEET, SEMT,
SECW, XEEW

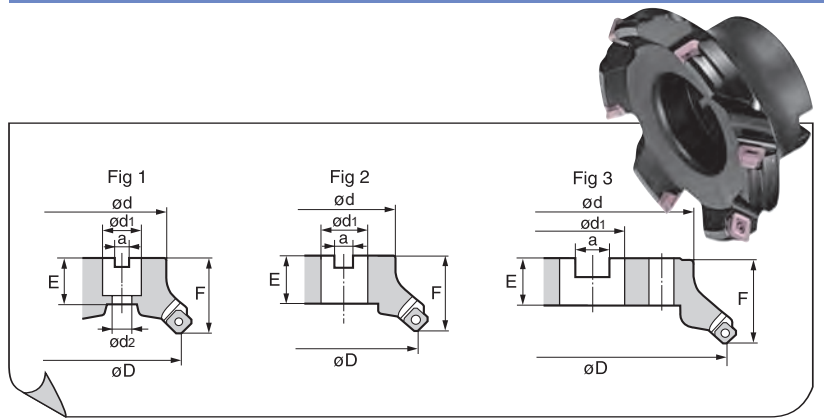
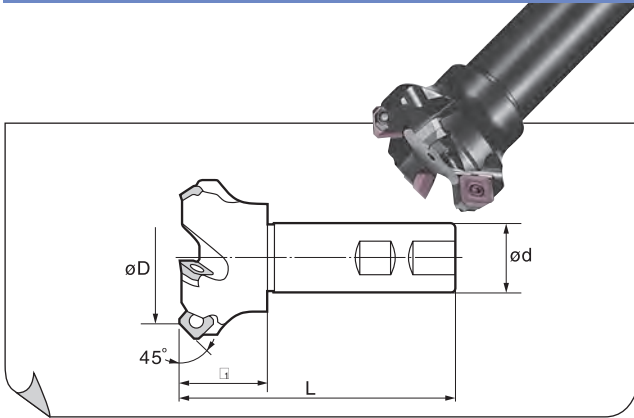

Weldon Shank Series								
Catalog Number	Stock	Dimensions (Inches)				Insert Diameter	Max D.O.C.	# of Inserts
		øD	ød	L	a			
WGC4200WR	▲	2.000	1.250	3.970	1.7094	0.375	0.250	3
WGC4250WR	▲	2.500	1.250	3.970	1.7094	0.375	0.250	4

* This dimension represents the actual "extension from holder".
● USA stocked item

Insert Application Key	
L	Light depth of cut applications
G	General purpose cutting applications
N	No chipbreaker
H	Heavy cutting applications

Shell Mill Series												
Catalog Number	Stock	Dimensions (Inches)						No. of Teeth	Max D.O.C.	Fig.	Pitch	
		øD	ød ₁	ød ₂	F	ød	a					E
WGC4200SR*	▲	2.000	0.750	0.406	1.750	1.500	0.312	1.020	3	0.250	1	Coarse
WGC4250SR†	▲	2.500	1.000	0.531	1.750	1.750	0.375	1.020	4	0.250	1	Coarse
WGC4300SR†	▲	3.000	1.000	0.531	1.750	2.250	0.375	1.020	4	0.250	1	Coarse
WGC4400SR*	▲	4.000	1.250	0.656	2.000	2.870	0.500	1.020	5	0.250	1	Coarse
WGC4500SR	▲	5.000	1.500	-	2.500	3.750	0.625	1.060	6	0.250	2	Coarse
WGC4600SR	▲	6.000	1.500	-	2.500	4.380	0.625	1.060	7	0.250	2	Coarse
WGC4800SR	▲	8.000	2.500	-	2.500	5.120	1.000	1.595	8	0.250	3	Coarse
WGC41000SR	▲	10.00	2.500	-	2.756	7.087	1.000	1.575	10	0.250	3	Coarse

Socket Head Cap Screw: *3/8-24x1, †1/2-20x1.5, ‡5/8-18x1.5

Shell Mill Series												
Catalog Number	Stock	Dimensions (Inches)						No. of Teeth	Max D.O.C.	Fig.	Pitch	
		øD	ød ₁	ød ₂	F	ød	a					E
WGC4200SR*	▲	2.000	0.750	0.406	1.750	1.500	0.312	1.020	4	0.250	1	Fine
WGC4250SR†	▲	2.500	1.000	0.531	1.750	1.750	0.375	1.020	5	0.250	1	Fine
WGC4300SR†	▲	3.000	1.000	0.531	1.750	2.250	0.375	1.020	6	0.250	1	Fine
WGC4400SR*	▲	4.000	1.250	0.656	2.000	2.870	0.500	1.020	7	0.250	1	Fine
WGC4500SR	▲	5.000	1.500	-	2.500	3.750	0.625	1.060	8	0.250	2	Fine
WGC4600SR	▲	6.000	1.500	-	2.500	4.380	0.625	1.060	10	0.250	2	Fine
WGC4800SR	▲	8.000	2.500	-	2.500	5.120	1.000	1.595	12	0.250	3	Fine

Socket Head Cap Screw: *3/8-24x1, †1/2-20x1.5, ‡5/8-18x1.5

Hardware					
Catalog Number	Seat	Insert Screw*	Seat Screw**	Insert Wrench	Seat Wrench
WGC42□□WR	WGCS13R	BFTX03512IP	BW0507F	TRDR15IP	LH035
WGC4□□□SR	WGCS13R	BFTX03512IP	BW0507F	TRDR15IP	LH035
WGC4□□□SR	WGCS13R	BFTX03512IP	BW0507F	TRDR15IP	LH035

* Torque specifications for insert screw=24-29 in/lbs.
** Torque specifications for seat screw=42-46 in/lbs.

Inserts																
Sumitomo Catalog Number	Material										Dimension (inch)					
	DL1000	ACK200	ACK300	ACP100	ACP200	ACP300	T250A	A30N	EH520	HT	DA2200	DA1000	L	T	Facet Width	Facet Radii
SEET13T3AGFNL	▲	▲	▲	▲	▲	▲										
SEET13T3AGSNG	▲	▲	▲	▲	▲	▲			▲							
SEET13T3AGSNN	▲	▲	▲	▲	▲	▲										
SEMT13T3AGSNG		▲	▲	▲	▲	▲		▲					0.528	0.156	0.0639	0.0394
SEMT13T3AGSNH		▲	▲	▲	▲	▲										
SEMT13T3AGSNL		▲	▲	▲	▲	▲										
NF-SECW13T3AGTNN											▲	▲				
XEEW13T3AGERW		▲														
NF-XEEW13T3AGFRW											▲	▲	0.707	0.156	0.320	-

Note: SEET is a close tolerance, peripheral ground insert type which may provide better surface finish and repeatability

- USA stocked item
- ★ Worldwide Warehouse item
- ▲ USA limited availability item

See pages 592-594
for recommended
running parameters



Metric

WGC4000

Applicable Insert:

SEET, SEMT,
SECW, XEEW

Metric

WGC/F4000

Applicable Insert:

SEET, SEMT,
SECW, XEEW

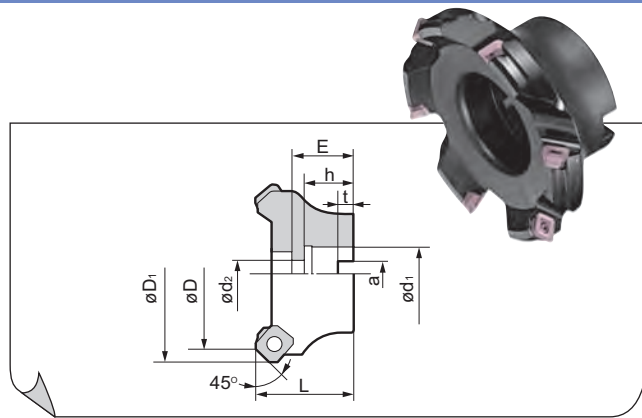
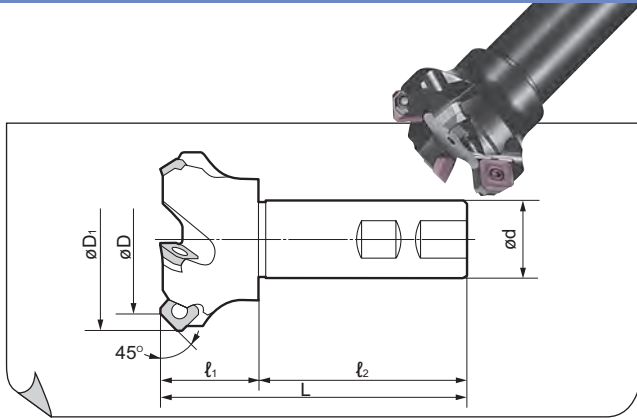

Weldon Shank Series (WGC 4000EW Type)

Catalog Number	Stock	Dimensions (mm)						# of Inserts
		ØD	ØD ₁	Ød	L ₁	L ₂	L	
WGC4032EW	▲	32	44	32	40	85	125	3
WGC4040EW	▲	40	52	32	40	85	125	3
WGC4050EW	▲	50	63	32	40	85	125	4
WGC4063EW	▲	63	76	32	40	85	125	5

▲ USA limited availability item

Shell Mill Series (WGC 4000RS Type)

Catalog Number	Stock	Dimensions (mm)								# of Teeth	
		ØD	ØD ₁	Ød ₁	Ød ₂	t	a	L	h		E
WGC4040RS	▲	40	52	16	9	5.6	8.4	40	18	28	3
WGC4050RS	▲	50	63	22	11	6.3	10.4	40	20	26	3
WGC4063RS	▲	63	76	22	11	6.3	10.4	40	20	26	4

Shell Mill Series (WGCF 4000RS Type)

Catalog Number	Stock	Dimensions (mm)								# of Teeth	
		ØD	ØD ₁	Ød ₁	Ød ₂	t	a	L	h		E
WGCF4050RS	▲	50	63	22	11	6.3	10.4	40	20	26	5
WGCF4063RS	▲	63	76	22	11	6.3	10.4	40	20	26	6

▲ USA limited availability item

Inserts

Sumitomo Catalog Number	Material										Dimension (inch)						
	Cermet					Uncoated		PCD			L	T	Facet Width	Facet Radii			
	DL1000	ACK200	ACK300	ACP100	ACP200	ACP300	T250A	A30N	EH520	H1					DA2200	DA1000	
SEET13T3AGFNL	▲	▲						▲	▲								
SEET13T3AGSNG	▲	▲	▲	▲	▲	▲		▲									
SEET13T3AGSNN	▲	▲	▲	▲	▲	▲		▲									
SEMT13T3AGSNG	▲	▲	▲	▲	▲	▲		▲									
SEMT13T3AGSNH	▲	▲	▲	▲	▲	▲											
SEMT13T3AGSNL	▲	▲	▲	▲	▲	▲											
NF-SECW13T3AGTNN											▲	▲					
XEEW13T3AGERW		▲															
NF-XEEW13T3AGFRW											▲	▲					

Note: SEET is a close tolerance, peripheral ground insert type which may provide better surface finish and repeatability

- USA stocked item
- ▲ USA limited availability item

Hardware

Catalog Number	Seat	Insert Screw*	Seat Screw**	Insert Wrench	Seat Wrench
WGC4□□□EW	-	BFTX03512IP	-	TRDR15IP	-
WGC/F4□□□EW/RS	WGCS13R	BFTX03512IP	BW0507F	TRDR15IP	LH035

* Torque specifications for insert screw=24-29 in/lbs.

**Torque specifications for seat screw=42-46 in/lbs.

**See pages 593-594
for recommended
running parameters**

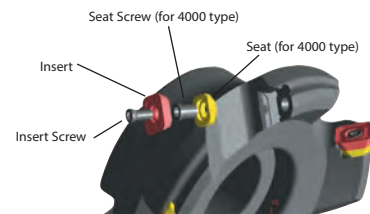

Rake Angle	Radial	-10° to -19°	-20° to -24°
	Axial	+20°	+20° to 22°
		(3000 Type)	(4000 Type)



Metric

WGC/F4000

Applicable Insert:

SEET, SEMT,
SECW, XEEW

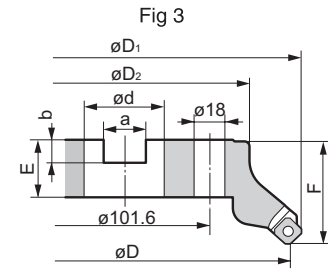
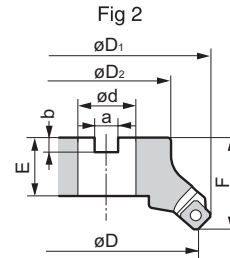
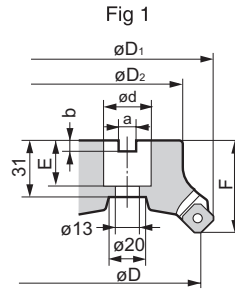

Shell Mill Series (WGC 4000 Type)												
Catalog Number	Stock	Dimensions								No. of Teeth	Weight (kg)	Fig.
		ØD	ØD ₁	ØD ₂	F	Ød	a	b	E			
WGC4080R	▲	80	93	60	50	25.4	9.5	6	25	4	1.0	1
WGC4100R	▲	100	113	70	50	31.75	12.7	8	32	5	1.5	2
WGC4125R	▲	125	138	80	63	38.1	15.9	10	38	6	2.6	2
WGC4160R	▲	160	173	100	63	50.8	19	11	38	7	4.0	2
WGC4200R	▲	200	213	130	63	47.625	25.4	14	35	8	6.6	3

Shell Mill Series (WGCF 4000 Type)												
Catalog Number	Stock	Dimensions								No. of Teeth	Weight (kg)	Fig.
		ØD	ØD ₁	ØD ₂	F	Ød	a	b	E			
WGCF4080R	▲	80	93	60	50	25.4	9.5	6	25	8	1.0	1
WGCF4100R	▲	100	113	70	50	31.75	12.7	8	32	10	1.5	2
WGCF4125R	▲	125	138	80	63	38.1	15.9	10	38	12	2.6	2
WGCF4160R	▲	160	173	100	63	50.8	19	11	38	16	4.0	2
WGCF4200R	▲	200	213	130	63	47.625	25.4	14	35	20	6.6	3

▲ USA limited availability item

Inserts																
Sumitomo Catalog Number	SEMT					XEEW		Dimension (inch)								
	DL1000	ACK200	ACK300	ACP100	ACP200	ACP300	T250A	A30N	EH520	H1	DA2200	DA1000	L	T	Facet Width	Facet Radii
SEET13T3AGFNL	▲	▲	▲	▲	▲	▲		▲	▲							
SEET13T3AGSNG		▲	▲	▲	▲	▲		▲								
SEET13T3AGSNN		▲	▲	▲	▲	▲		▲								
SEMT13T3AGSNG		▲	▲	▲	▲	▲		▲				0.528	0.156	0.0639	0.0394	
SEMT13T3AGSNH		▲	▲	▲	▲	▲		▲								
SEMT13T3AGSNL		▲	▲	▲	▲	▲		▲								
NF-SECW13T3AGTNN																
XEEW13T3AGERW		▲														
NF-XEEW13T3AGFRW													0.707	0.156	0.320	-

Note: SEET is a close tolerance, peripheral ground insert type which may provide better surface finish and repeatability

- USA stocked item
- ▲ USA limited availability item

Hardware					
Catalog Number	Seat	Insert Screw*	Seat Screw**	Insert Wrench	Seat Wrench
WGC/F 4□□R	WGCS13R	BFTX03512IP	BW0507F	TRDR15IP	LH035

* Torque specifications for insert screw=24-29 in/lbs.
**Torque specifications for seat screw=42-46 in/lbs.

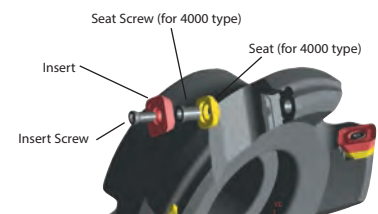

**See pages 593-594
for recommended
running parameters**





■ UFO Fine Pitch Face Mill Series
UFO "400" Face Mills

■ UFO Coarse Pitch Face Mill Series
UFO "400 & 500" Face Mills

■ UFO End Mill Series

Inserts Apply to UFO Endmills, 400 & 500 Face Mills

Sumitomo Cat. No.	Coated										Cermet		Uncoated		Dimensions (Inches)								
	ACZ310	ACZ330	ACZ350	ACZ350	ACZ350	AC211	EH20Z	K245R2	ACK200	ACK300	ACP100	ACP200	ACP300	T250A	TT10A	A30N	G10E	H10E	H1	I.C.	T	Facet Width	Figure
SFEN12T3AZFN																				0.500	0.156	0.088	1
SFKN12T3AZTN	▲	▲	▲	▲						▲	▲	▲				▲							
SFKN12T3AZFN	▲					▲	▲	▲	▲	▲	▲	▲					▲						
SFKR12T3AZEN					▲																		
SFKN1504AZTN*		▲	▲	▲	▲					▲	▲	▲								0.625	0.1875	0.088	2
SFKN1504AZFN*	▲					▲	▲	▲	▲	▲	▲	▲				▲							
UW12500R														▲			▲		0.500	0.156	0.218		

TN = "T" land FN = honed ▲ USA limited Availability Item *: UFO 500 Face Mill Coarse Pitch

Hardware for UFO 400 Face Mills

Catalog Number	Locator	Seat	*Insert Clamp	**Locator Clamp	Clamp Screw	Wrench
UFO4 □ □ EXR8	UF4KR	UF4SR	UFTWR	UFKWR	WB715T	TT25

* Torque specifications for insert clamp screw=49-53 in/lbs.
**Torque specifications for locator clamp screws=62-66 in/lbs.

Hardware for UFO 400 & 500 Face Mills

Catalog Number	Locator	Seat	*Insert Clamp	**Locator Clamp	Clamp Screw	Wrench
UFO402R						
UFO4 □ □ R	UF4KR	UF4SRS UF4SR	UFTWR	UFKWR	WB715T	TT25
UFO402L						
UFO4 □ □ L	UF4KL	UF4SLS UF4SL	UFTWL	UFKWL	WB715T	TT25
UFO5 □ □ R	UF5KR	UF5SR	UFTWR	UFKWR	WB715T	TT25
UFO5 □ □ L	UF5KL	UF5SL	UFTWL	UFKWL	WB715T	TT25

*Torque specifications for insert clamp screw=49-53 in/lbs.
**Torque specifications for locator clamp screws=62-66 in/lbs.

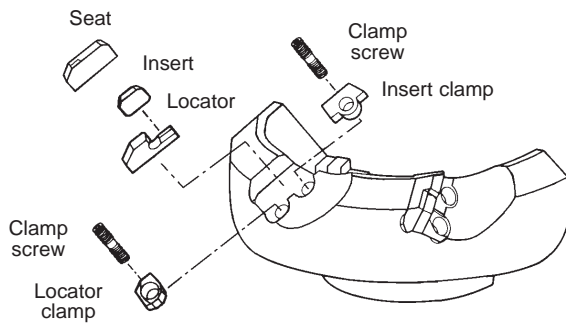

Indexable Milling
Shoulder Milling
Face Milling
High Feed Milling
Multi-purpose
Modular Tooling
UFO & SumiMill
Discontinued

Section of Discontinued Milling Cutters

INDEXABLE SHELL MILLS UFO SERIES

Applicable Insert: RGMN



■ UFOR Face Mill Series
UFOR "600" Face Mills



■ CHE Bridgeport Shank Series
CHE Shoulder Mills



■ CHE Weldon Shank Series
CHE Shoulder Mills

Inserts Apply to UFOR 600 Face Mills			
Sumitomo Cat. No.	Coated		Dimensions
	AC325 EH20Z		Insert Dia. T
RGMN2004SNS Edge prep = 0.008" x -30°	▲		0.7874 (20 mm) 0.1875
RGMN2004SNI Edge prep = 0.002" x -15°	▲		
RGMN2004SNT Edge prep = 0.002" x -30°	▲		

Note: use "SNS" for Steel applications
use "SNI" for Inconel applications
use "SNT" for Titanium applications

▲ USA limited availability item

Inserts Apply to CHE Shoulder Mills											
Sumitomo Cat. No.	Coated		Cermet	Uncoated		PCD		Dimensions (Inches)			
	AC230 AC325 AC211		T250A	A30N G10E H1		DA2200 DA150 DA1000		I.C.	T		Figure
TECN32R								0.375	0.125		1
TEEN32R								0.375	0.125		2
NF-TEEN32R								0.375	0.125		2
TEKN32TR	▲							0.375	0.125		1
TECN43R								0.500	0.1875		1
TEEN43R								0.500	0.1875		2
NF-TEEN43R								0.500	0.1875		2
TEKN43R	▲	▲						0.500	0.1875		1
TEKN43TR	▲	▲	▲					0.500	0.1875		1

"T" denotes inserts with a T-Land

Hardware for UFOR 600 Face Mills					
Catalog Number	Locator	Insert Clamp	Locator Screw**	Insert Screw*	Wrench
UFOR6 □ □ R	GRKR	GRWR	BH0410T	WB8-20	TH040 TRD15

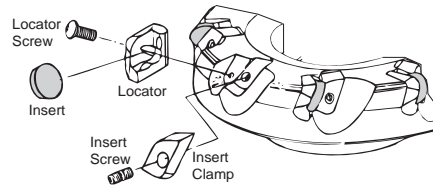

*Torque specifications for insert clamp screw=58-62 in/lbs.

**Torque specifications for locator clamp screws=35-40 in/lbs.

Hardware for CHE Bridgeport							
Catalog Number	Locator	Clamp	Locator Screw	Clamp Screw	Retaining Ring	Clamp Wrench	Locator Wrench
CHE3-1 □ □ □ RR8	-	CCH5R	-	BHE0510	ER04	-	LH030
CHE4-2000RR8	LCE4R	CEWR	FBH0512	WB8R-16T	-	TT27	TH030

Hardware for CHE Weldon							
Catalog Number	Locator	Clamp	Locator Screw	Clamp Screw	Retaining Ring	Clamp Wrench	Locator Wrench
CHE2- □ □ □ RW	-	CCH4R	-	BHE0407	ER03	-	TH025
CHE3- 1 □ □ □ RW	-	CCH5R	-	BHE0510	ER04	-	LH030
CHE4- 2000RW	LCE4R	CEWR	FBH0512	WB8R-16T	-	TT27	TH030



SUMIMILL SERIES

Applicable Insert: SDC, NF-SDC, APW

Section of Discontinued Milling Cutters



■ APG Face Mill Series
APG 400 Face Mills

Inserts Apply to APG 400 Face Mills

Sumitomo Cat. No.	Coated		Uncoated		PCD			Dimensions (Inches)				
	AC325		A30N	H1	DA2200	DA150	DA200	DA1000	I.C.	T	Facet Width	Figure
SDC42R			▲		▲	▲			0.500	0.125	0.0938	1
SDC42TR	▲		▲						0.500	0.125	0.0938	1
NF-SDC42R					▲		▲		0.500	0.125	0.0938	2
APW4R					▲	▲			0.500	0.125	0.193	3

"T" denotes inserts with T-Land

▲ USA limited availability item

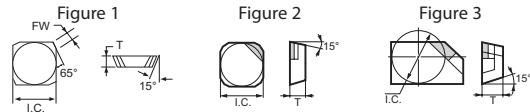

Hardware for APG 400 Face Mills

Catalog Number	Locator	Insert Clamp	Clamp Bolt	Cap Screw	Wrench
APG403R			WB820		TH040
APG404R					
APG405R	LAP40RL	ATW45RL	WB824T	BXF0520RL	TT27
APG406R			WB824TL		
APG408R					

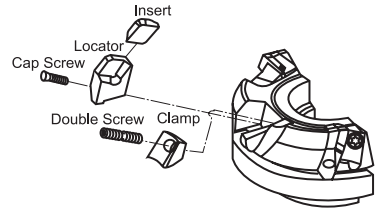

Indexable Milling
Shoulder Milling
Face Milling
High Feed Milling
Multi-purpose
Modular Tooling
UFO & SumiMill
Discontinued



■ DNF Face Mill Series

Inserts Apply to DNF Face Mills

Sumitomo Cat. No.	Coated	Cermet	Uncoated	CBN	Dimensions (Inches)					
	ACZ310	AC325	T250A	HT0E	BNS800	I.C.	T	R	Facet Width	Figure
CSNH43M	▲					0.500	0.189	-	0.500	1
SNG432		▲			•	0.500	0.1875	0.0312	-	2
SNG433					•			0.0469		
SNG434					•			0.0625		
SNMN433	▲	▲	▲		▲	0.500	0.1875	0.0469	-	
NW100*			▲			-	0.197	-	-	3

▲ USA limited availability item • USA stocked item

*Wiper requires LNF40R cartridge

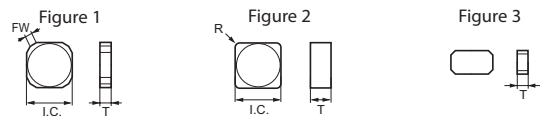

Hardware for DNF Face Mills

Catalog Number	Locator	Insert Clamp	Locator Clamp	Insert Screw*	Wrench
DNF □ □ □ R	LNF40R	FTW40R	BX0510	WB830T	TT27 LH040

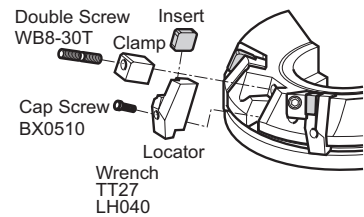

Torque specifications for locator clamp (WB830T)= 71-75 in/lbs.

Torque specifications for insert clamp (WB830T)= 57-62 in/lbs.



Section of Discontinued Milling Cutters

INDEXABLE ENDMILLS

SUMIMILL SERIES

Applicable Insert: CSNH, SNG, SNMN, NW



■ CHG Face Mill Series

Inserts Apply to CHG Face Mills

Sumitomo Cat. No.	Coated			Cermet			Uncoated			PCD			Dimensions (Inches)		
	AC230	AC325	AC211	T250A	A30N	G10E	H1	DA2200	DA150	DA1000	I.C.	T	Figure		
TECN43R											0.500	0.1875	1		
TEEN43R											0.500	0.1875	2		
NF-TEEN43R											0.500	0.1875	2		
TEKN43R	▲	▲									0.500	0.1875	1		
TEKN43TR	▲	▲		▲							0.500	0.1875	1		

"T" denotes inserts with a T-Land.

▲ USA limited availability item

Hardware for CHG Face Mills						
Catalog Number	Locator	Clamp	Clamp Bolt	Locator Screw	Clamp Wrench	Locator Wrench
CHG403R	LCH4R	CHWR	FBX0811	FBH0512	TH040	TH030
CHG404R						
CHG405R						
CHG406R			FBX0817			
CHG407R						
CHG408R						

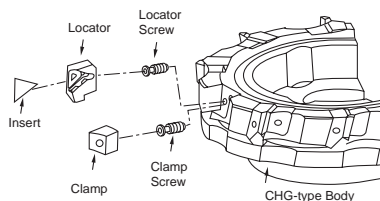

■ CPG 400 & 500 Face
Mill Series

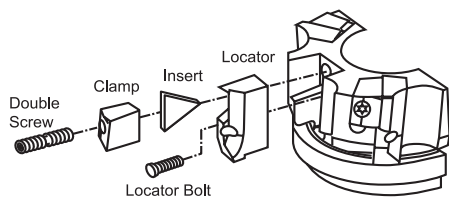

Inserts Apply to CPG 400 & 500 Face Mills

Sumitomo Cat. No.	Coated			Cermet			Uncoated			Dimensions (Inches)			
	AC230	AC325	AC211	EH20Z	T250A	A30N	G10E	I.C.	T	R	Figure		
TPCH43R								0.500	0.1875		1		
TPCH43TR	▲	▲						0.500	0.1875		1		
TPC53P12R								0.625	0.1875		2		
TPC53P12RA								0.625	0.1875		2		
TPG431		▲						0.500	0.1875	0.0156	3		
TPG432		▲		▲				0.500	0.1875	0.0312	3		
TPG433		▲		▲				0.500	0.1875	0.0469	3		
TPMN431		▲						0.500	0.1875	0.0156	3		
TPMN432		▲						0.500	0.1875	0.0312	3		
TPMN433		▲						0.500	0.1875	0.0469	3		
TPMN434		▲						0.500	0.1875	0.0625	3		

"T" denotes inserts with a T-Land.

▲ USA limited availability item

Hardware for 400 Series						
Catalog Number	Locator	Clamp	Clamp Bolt	Locator Bolt	Wrench	
CPG03R	LCP40R	PTW40R	WB8-24T	BX0510	TT27	
CPG04R						
CPG05R						
CPG05R						PTW41R
CPG06R						

Hardware for 500 Series						
Catalog Number	Locator	Clamp	Clamp Bolt	Locator Clamp Bolt	Wrench	
CPG504R	LCP50R	PTW50R	WB8-24T	BH0408	TT27	
CPG505R						
CPG506R						
CPG508R						PTW51R
CPG510R						



SUMIMILL SERIES

Applicable Insert: SPCH, SPG, SPMN, DPW

Section of Discontinued Milling Cutters

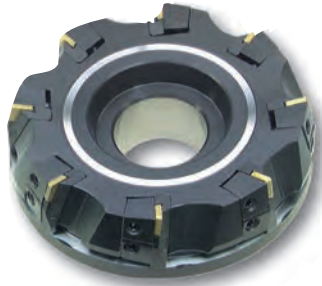

■ DPG 400 Face Mill Series

Inserts for DPG 400 Face Mills												
Sumitomo Cat. No.	Coated		Uncoated		Dimensions (Inches)							
	ACZ310	AC230	AC325	AC211	EH20Z	A30N	G10E	I.C.	T	Facet Width	R	Figure
SPCH42R	▲							0.500	0.125	0.125	N/A	1
SPCH42TR	▲											
SPG421			▲								0.0156	
SPG422			▲		▲						0.0312	
SPG423					▲						0.0469	
SPMN421						▲		0.500	0.125	N/A	0.0156	2
SPMN422			▲								0.0312	
SPMN423			▲			▲					0.0469	
SPMN424			▲								0.0625	
DPW500R					▲			0.480	0.126	0.126	N/A	3

"T" denotes inserts with a T-Land.
▲ USA limited availability item

Hardware for DPG 400 Face Mills

Catalog Number	Locator	Locator Clamp	Insert Clamp	Clamp Bolt	Wrench	
DPG403R	GL40R	GLW40R	GTW40R	WB830T	TT27	
DPG404R		GLW41R	GTW41R	WB824T		
DPG406R						
DPG408R						
DPG410R		GLW42R	GTW42R	WB830T		
DPG412R						

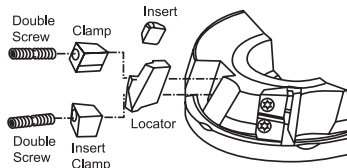

Torque specifications for locator clamp (WB830T)=71-75 in/lbs.
Torque specifications for insert clamp (WB830T)=57-62 in/lbs.



■ DPG 500 Face Mill Series

Inserts Apply to DPG 500 Face Mills												
Sumitomo Cat. No.	Coated		Uncoated		Dimensions (Inches)							
	ACZ310	AC230	AC325	AC211	EH20Z	A30N	G10E	I.C.	T	Facet Width	R	Figure
SPCH53TR			▲					0.625	0.1875	0.1875	N/A	1
SPCH53TRR			▲									
SPMN533			▲			▲		0.625	0.1875	0.0469	N/A	2

"T" denotes inserts with a T-Land.
▲ USA limited availability item

Hardware for DPG 500 Face Mills

Catalog Number	Locator	Locator Clamp	Insert Clamp	Clamp Bolt	Wrench	
DPG503R	GL50R	GLW50R	GTW50R	WB830T	TT27	
DPG504R		GLW51R	GTW51R	WB824T		
DPG506R						
DPG508R						
DPG510R		GLW52R	GTW52R	WB830T		
DPG512R						

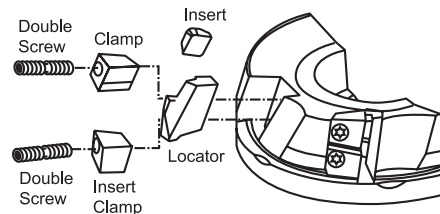

Torque specifications for locator clamp (WB830T)=71-75 in/lbs.
Torque specifications for insert clamp (WB830T)=57-62 in/lbs.



Section of Discontinued Milling Cutters

INDEXABLE SHELLMILLS SUMIMILL SERIES

Applicable Insert: SDKN



■ EHG 400 Face Mill Series

Inserts Apply to EHG Face Mills

Sumitomo Cat. No.	Coated						Cermet		Uncoated			Dimensions (in)					
	ACZ310	ACZ330	ACZ350	AC230	AC325	AC211	EH20Z	T250A		A30	A30N	G10E	I.C.	T	R	Facet Width	Fig.
SEKN42M	▲											▲	0.500	0.125	N/A	0.0625	1
SEKN42MT		▲	▲	▲	▲			▲									
SEKN53M	▲												0.625	0.1875			
SEKN53MT		▲	▲	▲	▲			▲									
SEMR42M					▲								0.500	0.125			
SEC422						▲									0.0312	N/A	2

"M" denotes honed inserts
 "MT" denotes inserts with a T-Land
 ▲ USA limited availability item

Hardware for EHG Face Mills

Catalog Number	Seat	Clamp	Clamp & Locator Screw	Wrench
EHG4 □ □	EHK4R	EHW4R	EBHX0512	TH040

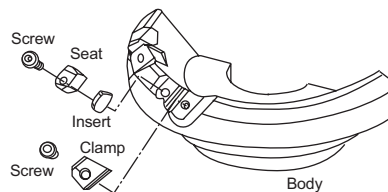

■ FPG 400 & 500 Face Mill Series

Inserts Apply to FPG Face Mills

Sumitomo Cat. No.	Coated						Cermet		Uncoated		Dimensions (in)				
	ACZ310	ACZ330	ACZ350	AC230	AC325	AC211	EH20Z	T250A		A30N	G10E	DA150	I.C.	T	Facet Width
SDKN42M	▲											▲	0.500	0.125	0.0781
SDKN42MT		▲	▲	▲	▲			▲							
SDKN53M													0.625	0.1875	
SDKN53MT				▲	▲			▲							

"M" denotes honed inserts
 "MT" denotes inserts with a T-Land
 ▲ USA limited availability item

Hardware for FPG Face Mills

Catalog Number	Locator	Clamp	Clamp Screw**	Locator Screw*	Clamp Wrench	Locator Wrench
FPG4 □ □ R	LFP4R	FPWR	FBX0817	FBH0512	TH040	TH030
FPG5 □ □ R	LFP5R					

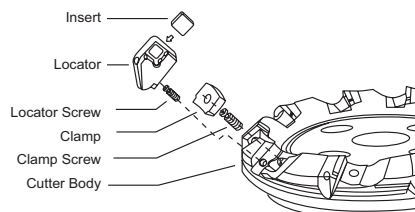

*Torque specification for FBH0512=58-62 in/lbs.
 **Torque specification for FBX0817=44-49 in/lbs.





*DISCONTINUED ITEMS



Inserts & Hardware for Discontinued and/or Limited Inventory WaveMills

WEM 4000/5000





Hardware		
		
Catalog Number	Screw	Wrench
WEM3□□□RW□	BFTX02506N	TRD08
WEM3□□□EX	BFTX02506N	TRD08

Torque specifications for BFTX02506N insert screw=10-14 inch/lbs.

Hardware for WEM		
		
Catalog Number	Screw	Wrench
WMM10□□□□M	BFTX02506N	TRD08



Torque specifications for BFTX02506N insert screw=10-14 inch/lbs.

Hardware		
		
Catalog Number	Screw	Wrench
WMM16□□□□M	BFTX03584	TRD15

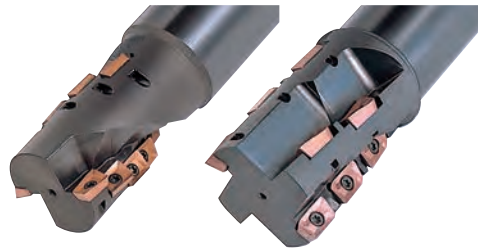

Torque specifications for BFTX03584 insert screw=27-31 inch/lbs.

WRM 10000/16000



Hardware		
		
Catalog Number	Screw	Wrench
WRM10□□□□M	BFTX02506N	TRD08

Torque specifications for BFTX02506N insert screw=10-14 inch/lbs.

Hardware		
		
Catalog Number	Screw	Wrench
WRM16□□□□M	BFTX03588	TRD15



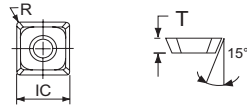

Torque specifications for BFTX03588 insert screw=27-31 inch/lbs.

WFM 400/500



Inserts Apply to WFM Cutters											
											
	Coated	Uncoated	Dimensions (Inches)								
Sumitomo Cat. No.	ACZ30	ACZ310	ACZ330	ACZ350	K245R2	G10E			I.C.	T	R
XDMT120408PDEN	▲	▲	▲	▲	▲				0.500	0.1875	0.031
XDMT120408PDENH	▲	▲	▲	▲	▲				0.500	0.1875	0.031
XDMT150408PDEN	▲	▲	▲	▲	▲				0.625	0.1875	0.031

▲ USA limited availability item

Hardware for WFM Cutters					
					
Catalog Number	Seat	Insert Screw	Set Screw	Wrench	Wrench
WFM□40□R	WFMS4R	BFTX0414	BT0506	TRD20	TH025
WFM□50□R	WFMS5R	BFTX0515N	BT0506	TRD20	TH025



PWC



■ SumiEdge Mill Cutter Bodies

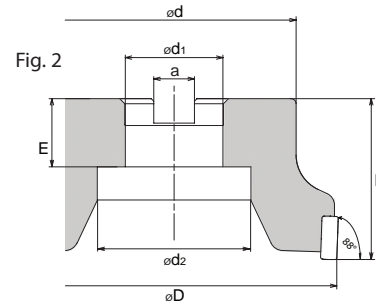
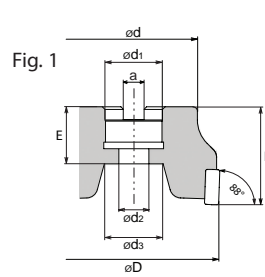

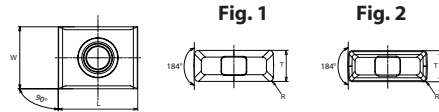
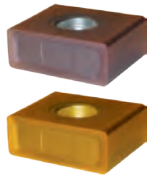

Inserts Apply to SumiEdge Mill Cutter Bodies



Sumitomo Cat. No.	Grade		Dimensions (Inches)					Fig.
	ACK200	ACK300	L	W	T	R	Facet Width	
LNMX160608PNSN-G	▲	▲	0.634	0.476	0.250	0.032	0.218	1
LNMX160608PNSN-H	▲	▲	0.634	0.476	0.250	0.032	0.218	2
LNMX1606-W		▲	0.636	0.476	0.250	0.032	*	-

*See page 000 for facet width information.

Hardware

		
Applicable Cutter	Insert Screw	Wrench
PWC Series	BFTX0511N	TTX15W



Pages 427-439



Endmill Series

SOLID CARBIDE ENDMILLS	PAGES
GSX Introduction Page	427
GSX Cutting Conditions.....	428
GSX S & C Type	429-430
GSX Ballnose Type.....	431-432
GSXVL Type	433-434
GSX Application Examples.....	435
Aurora Coat Endmills	436-437
BNBP Endmills.....	438
NPDB Endmills	439

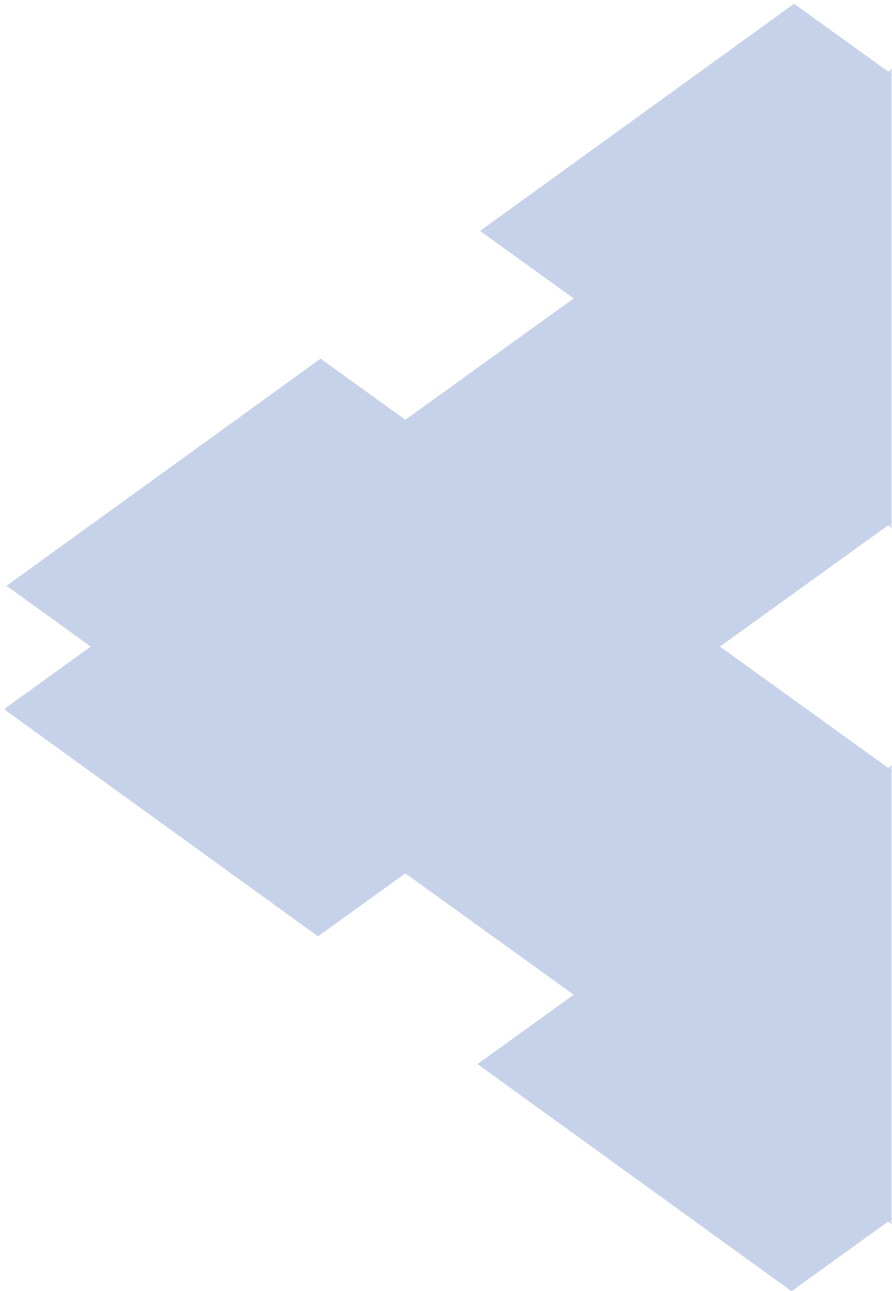

1-800-950-5202
www.sumicarbide.com



■ Features & Benefits

- Wide variation of three flute types and four flute lengths enable use in a wide variety of applications.
- Fine carbide substrate provides high traverse rupture strength and excellent thermal shock resistance improving reliability in wet cutting applications.
- **GSX Coating** provides improved reliability and longer tool life.
- Large rake angle and unique flute design improve sharpness and chip evacuation.
- Corner edge with gash land improves cutting edge strength.
- **Sharper edge** S type and **fracture resistant** C type added to the 2D size series.

■ Product Range		Inch GSX Endmills					
Application	Flutes	Flute Length					
		1.5D	2D		3D		4D
General Purpose	2	C Type	S Type	C Type	S Type	C Type	C Type
		 φ1/16" to φ1"	 φ1/16" to φ1"	 φ1/16" to φ1"	 φ1/16" to φ1"	 φ1/16" to φ1"	 φ1/16" to φ1"
	4	 φ1/16" to φ1"	 φ1/16" to φ1"	 φ1/16" to φ1"	 φ1/16" to φ1"	 φ1/16" to φ1"	 φ1/16" to φ1"

■ Product Range		Metric GSX Endmills					
Application	Flutes	Flute Length					
		1.5D	2D		3D		4D
General Purpose	2	C Type	S Type	C Type	S Type	C Type	C Type
		 φ1.0 to φ 20.0mm	 φ0.5 to φ 20.0mm	 φ0.5 to φ 25.0mm	 φ0.5 to φ 20.0mm	 φ1.0 to φ 20.0mm	 φ1.0 to φ 20.0mm
	3	 φ1.0 to φ 20.0mm		 φ1.0 to φ 20.0mm			
	4	 φ1.0 to φ 20.0mm	 φ1.0 to φ 20.0mm	 φ1.0 to φ 25.0mm	 φ1.0 to φ 20.0mm	 φ1.0 to φ 20.0mm	 φ1.0 to φ 20.0mm

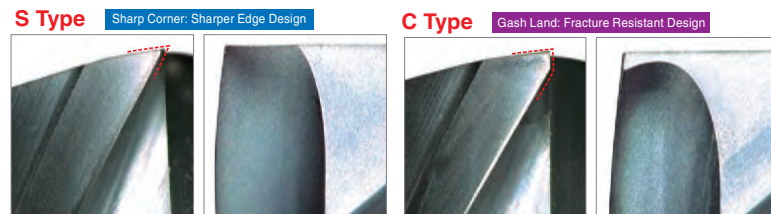

Note: When using endmills with gash land, some material remains as shown on the right. If you need sharp corners, use the S Type.

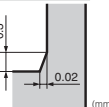

■ Recommended Milling Examples

Application	Surface Milling		Groove Milling		Groove Finishing	
	Roughing	Finishing	Roughing	Finishing	Roughing	Finishing
Form						
S Type	◎	◎		○ *2		◎
C Type	◎	○	◎	◎	◎	○

S Type is best for removing inside corners *2 : Use with small depth of cut.

■ Application Range

	P				H			M	S	K	N				
	General Structure Rolled Steel	Carbon Steel	Alloy Steel	Pre-hardened Steel	Hardened Steel			Stainless Steel	Ti Alloy	Heat Resistant Alloy	Cast Iron	Al Alloy	Copper Alloy	Graphite	CFRP
	◎	◎	◎	◎	◎			◎	○	○	○				

■ Multi-Purpose

Optimized flute design of slotted 3 flute (short) type reduces cutting resistance.

1. Allows drilling, slot milling and other continuous (compound) applications.
2. Perfect for use on thin walls and small machining centres.



Speeds and Feeds reflect roughing and finishing applications

ISO	GSX 1.5D & 2D Endmills			Cutting Diameter										
	Material	Hardness (Bhn)	SFM	1/8	3/16	1/4	5/16	3/8	7/16	1/2	9/16	5/8	3/4	1
				Feed/Tooth	Feed/Tooth	Feed/Tooth	Feed/Tooth	Feed/Tooth	Feed/Tooth	Feed/Tooth	Feed/Tooth	Feed/Tooth	Feed/Tooth	Feed/Tooth
P	Low and Medium Carbon Steels	<250	150-400	.0005-.0024	.0007-.0025	.0008-.0035	.0008-.0037	.001-.0045	.0012-.0055	.0014-.0066	.0016-.0075	.002-.0095	.002-.010	.002-.0105
	Medium Carbon Alloy Steels	<250	140-375	.0005-.0024	.0007-.0025	.0008-.0035	.0008-.0037	.001-.0045	.0012-.0055	.0014-.0066	.0016-.0075	.002-.0095	.002-.010	.002-.0105
	Medium-High Carbon Steels	>250	175-300	.0005-.0015	.0007-.002	.0008-.003	.0008-.0033	.001-.0039	.0012-.0045	.0014-.0056	.0016-.0062	.002-.0075	.002-.008	.002-.009
	Free Machining Steels and Alloys	<250	175-350	.0005-.002	.0008-.0025	.0008-.0035	.0008-.004	.001-.0045	.0012-.0055	.0014-.0058	.0016-.0072	.002-.0075	.002-.0085	.002-.009
	Tool Steels	<250	150-300	.0005-.0017	.0005-.0024	.0008-.003	.0008-.0035	.001-.0045	.001-.0055	.0012-.0066	.0016-.0075	.002-.0075	.002-.0085	.002-.009
250 - 350		100-225	.0005-.0015	.0005-.0019	.0008-.0025	.0008-.003	.001-.0036	.001-.0044	.0012-.0055	.0013-.0065	.0015-.0075	.002-.0085	.002-.0088	
M	Martensitic and Ferritic	>350	75-150	.0005-.001	.0005-.0012	.0006-.0014	.0008-.0017	.0008-.0022	.0008-.0028	.001-.0034	.001-.0041	.0015-.0051	.002-.0055	
		<250	150-350	.0005-.0013	.0008-.0013	.0008-.0016	.0008-.0019	.001-.0025	.001-.0031	.001-.0037	.001-.0044	.001-.005	.001-.0055	.001-.0062
	Austenitic	<250	150-350	.0005-.0013	.0005-.0013	.0005-.0016	.0008-.0019	.0008-.0025	.001-.0031	.001-.0037	.001-.0044	.001-.005	.001-.0055	.001-.0062
K	Precipitation Hardening	<280	90-300	.0005-.0012	.0005-.0013	.0008-.0015	.001-.0019	.001-.0025	.001-.003	.001-.0035	.001-.0041	.001-.0048	.001-.0055	.001-.0065
		Grey Cast Iron	250-400	.0008-.0024	.001-.0028	.001-.0031	.001-.0033	.001-.004	.001-.0045	.001-.006	.001-.0067	.001-.0075	.001-.0085	.001-.010
S	Ductile Iron	160-350	.0005-.0024	.0005-.0028	.0008-.0031	.001-.0033	.001-.004	.001-.0045	.001-.0059	.001-.0067	.001-.0075	.001-.0085	.001-.010	
		Exotic Alloys: Inconel, Hastalloy, Waspalloy, etc.	75-125	.0005-.0015	.0008-.0018	.0008-.0021	.0008-.0024	.001-.0028	.001-.0033	.001-.0036	.001-.004	.001-.0045	.001-.005	.001-.006
N	Non-Ferrous Material	600-1500	.001-.0024	.001-.003	.001-.0035	.001-.004	.001-.0045	.001-.005	.001-.006	.001-.008	.001-.0095	.001-.011	.001-.012	

ISO	GSX 3D Endmills			Cutting Diameter										
	Material	Hardness (Bhn)	SFM	1/8	3/16	1/4	5/16	3/8	7/16	1/2	9/16	5/8	3/4	1
				Feed/Tooth	Feed/Tooth	Feed/Tooth	Feed/Tooth	Feed/Tooth	Feed/Tooth	Feed/Tooth	Feed/Tooth	Feed/Tooth	Feed/Tooth	Feed/Tooth
P	Low and Medium Carbon Steels	<250	125-280	.0005-.0021	.0007-.0022	.0008-.0031	.0008-.0034	.001-.0041	.0012-.005	.0014-.006	.0016-.0072	.002-.008	.002-.009	.002-.010
	Medium Carbon Alloy Steels	<250	100-255	.0005-.0021	.0007-.0022	.0008-.0031	.0008-.0034	.001-.0041	.0012-.005	.0014-.006	.0016-.0072	.002-.008	.002-.009	.002-.010
	Medium-High Carbon Steels	>250	90-200	.0005-.0014	.0007-.0018	.0008-.0027	.0008-.003	.001-.0036	.0012-.0041	.0014-.005	.0016-.0059	.002-.0069	.002-.008	.002-.009
	Free Machining Steels and Alloys	<250	110-230	.0005-.0018	.0008-.0022	.0008-.0031	.0008-.0036	.001-.0041	.0012-.0049	.0014-.006	.0016-.0071	.002-.0081	.002-.0092	.002-.0103
	Tool Steels	<250	100-200	.0005-.0015	.0005-.0019	.0008-.0027	.0008-.0031	.001-.0041	.001-.005	.0012-.0059	.0016-.0069	.002-.008	.002-.0091	.002-.0102
250 - 350		85-165	.0005-.0013	.0005-.0017	.0008-.0022	.0008-.0029	.001-.0033	.001-.004	.0012-.0048	.0013-.0059	.0015-.007	.002-.0081	.002-.0092	
>350		75-145	.0005-.001	.0005-.0011	.0006-.0013	.0008-.0017	.001-.0023	.0008-.0026	.001-.003	.001-.0037	.001-.0042	.0015-.0047	.002-.0054	
M	Martensitic and Ferritic	<250	90-230	.0005-.0013	.0008-.0011	.0008-.0015	.0008-.002	.001-.0025	.001-.0029	.001-.0033	.001-.004	.001-.0046	.001-.0051	.001-.0058
		<250	90-230	.0005-.0013	.0005-.0011	.0005-.0015	.0008-.002	.0008-.0025	.001-.0029	.001-.0033	.001-.004	.001-.0046	.001-.0051	.001-.0058
	Austenitic	<250	110-205	.0005-.0011	.0005-.0016	.0008-.002	.0008-.0024	.001-.0027	.0011-.0035	.0012-.0038	.0012-.0042	.0014-.0046	.0015-.005	.002-.006
K	Precipitation Hardening	<280	90-180	.0005-.0011	.0005-.0012	.0008-.0015	.0008-.0035	.001-.0022	.001-.0027	.001-.0032	.001-.0037	.001-.0043	.001-.005	.001-.006
		Grey Cast Iron	250-280	.0008-.002	.001-.0025	.001-.0028	.0008-.0031	.001-.0035	.001-.0039	.001-.0046	.001-.005	.001-.0054	.001-.006	.001-.007
S	Ductile Iron	160-225	.0005-.002	.001-.0025	.001-.0028	.0015-.0031	.001-.0035	.001-.0039	.001-.0046	.001-.005	.001-.0054	.001-.006	.001-.007	
		Exotic Alloys: Inconel, Hastalloy, Waspalloy, etc.	75-115	.0005-.0012	.0008-.0015	.0008-.0018	.0008-.0021	.001-.0025	.001-.0029	.001-.0033	.001-.0038	.001-.0044	.001-.0051	.001-.0057
N	Non-Ferrous Material	550-1100	.001-.0021	.001-.0027	.001-.0031	.0008-.0036	.001-.0042	.001-.0053	.001-.0064	.001-.0075	.001-.0085	.001-.0095	.001-.0105	

ISO	GSX 4D Endmills			Cutting Diameter										
	Material	Hardness (Bhn)	SFM	1/8	3/16	1/4	5/16	3/8	7/16	1/2	9/16	5/8	3/4	1
				Feed/Tooth	Feed/Tooth	Feed/Tooth	Feed/Tooth	Feed/Tooth	Feed/Tooth	Feed/Tooth	Feed/Tooth	Feed/Tooth	Feed/Tooth	Feed/Tooth
P	Low and Medium Carbon Steels	<250	115-260	.0005-.0018	.0007-.0019	.0008-.0028	.0008-.0031	.001-.0036	.0012-.0045	.0014-.0054	.0016-.0065	.002-.007	.002-.0075	.002-.009
	Medium Carbon Alloy Steels	<250	90-235	.0005-.0018	.0007-.0019	.0008-.0028	.0008-.0031	.001-.0036	.0012-.0045	.0014-.0054	.0016-.0065	.002-.007	.002-.0075	.002-.009
	Medium-High Carbon Steels	>250	80-180	.0005-.0013	.0007-.0016	.0008-.0024	.0008-.0027	.001-.0032	.0012-.0037	.0014-.0045	.0016-.0053	.002-.006	.002-.007	.002-.0081
	Free Machining Steels and Alloys	<250	100-210	.0005-.0016	.0008-.002	.0008-.0027	.0008-.0032	.001-.0036	.0012-.004	.0014-.005	.0016-.006	.002-.007	.002-.008	.002-.009
	Tool Steels	<250	90-160	.0005-.0013	.0005-.0017	.0008-.0024	.0008-.0027	.001-.0033	.001-.004	.0012-.005	.0016-.006	.002-.007	.002-.008	.002-.009
250 - 350		85-145	.0005-.0011	.0005-.0015	.0008-.002	.0008-.0025	.001-.003	.001-.0035	.0012-.0043	.0013-.0052	.0015-.0062	.002-.0073	.002-.0084	
>350		75-125	.0005-.001	.0005-.0011	.0006-.0012	.0008-.0013	.0008-.0018	.0008-.0023	.001-.0027	.001-.0031	.001-.004	.0015-.0045	.002-.005	
M	Martensitic and Ferritic	<250	85-210	.0005-.0011	.0008-.0011	.0008-.0012	.0008-.0015	.001-.002	.001-.0029	.001-.0033	.001-.004	.001-.0046	.001-.0051	.001-.0058
		<250	85-210	.0005-.0011	.0005-.0011	.0005-.0012	.0008-.0015	.0008-.002	.001-.0029	.001-.0033	.001-.004	.001-.0046	.001-.0051	.001-.0058
	Austenitic	<250	100-185	.0005-.0011	.0005-.0012	.0008-.0016	.001-.002	.001-.0024	.0011-.0028	.0012-.0032	.0012-.0036	.0014-.004	.0015-.0045	.002-.0052
K	Precipitation Hardening	<280	90-160	.0005-.0011	.0005-.0011	.0008-.0013	.001-.0015	.001-.0018	.001-.0024	.001-.0029	.001-.0033	.001-.0037	.001-.0041	.001-.0046
		Grey Cast Iron	240-250	.0008-.002	.001-.0025	.001-.0027	.001-.0029	.001-.0033	.001-.0037	.001-.004	.001-.0044	.001-.0049	.001-.0055	.001-.0065
S	Ductile Iron	160-200	.0008-.002	.001-.0025	.001-.0027	.001-.0029	.001-.0033	.001-.0037	.001-.004	.001-.0044	.001-.0049	.001-.0055	.001-.0065	
		Exotic Alloys: Inconel, Hastalloy, Waspalloy, etc.	75-90	.0005-.001	.0008-.0012	.0008-.0015	.0008-.0018	.001-.0023	.001-.0026	.001-.003	.001-.0035	.001-.004	.001-.0046	.001-.0051
N	Non-Ferrous Material	500-1000	.001-.0017	.001-.0022	.001-.0027	.001-.0032	.001-.0038	.001-.0045	.001-.0042	.001-.005	.001-.0059	.001-.007	.001-.01	



GSX Endmills - Sharp Edge (S) INCH Lineup

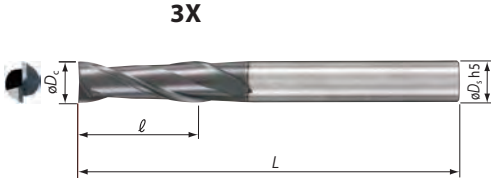
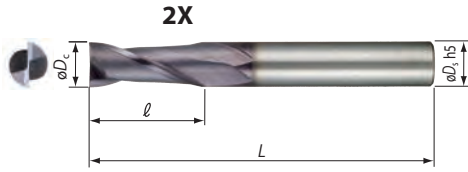

■ Endmill Identification
(GSX MILL Series Only)

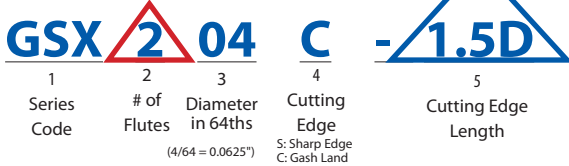

Sharp Edge (S)	Diameter ϕD_c		Shank Diameter ϕD_s (Inch)	2			3				
	Fraction	Inch		Flute		OAL L (Inch)	Flute Length ℓ (Inch)	Flute		OAL L (Inch)	Flute Length ℓ (Inch)
				2	4			2	4		
GSX Δ 04S- Δ D	1/16	0.0625	0.1250	●	●	1.500	0.1250	●	●	1.500	0.1875
GSX Δ 06S- Δ D	3/32	0.0938	0.1250	●	●	1.500	0.1875	●	●	1.500	0.2813
GSX Δ 08S- Δ D	1/8	0.1250	0.1250	●	●	2.000	0.2500	●	●	2.000	0.3750
GSX Δ 10S- Δ D	5/32	0.1563	0.1875	●	●	2.000	0.3125	●	●	2.000	0.4688
GSX Δ 12S- Δ D	3/16	0.1875	0.1875	●	●	2.000	0.3750	●	●	2.000	0.5625
GSX Δ 14S- Δ D	7/32	0.2188	0.2500	●	●	2.000	0.4376	●	●	2.000	0.6564
GSX Δ 16S- Δ D	1/4	0.2500	0.2500	●	●	2.000	0.5000	●	●	2.000	0.7500
GSX Δ 18S- Δ D	9/32	0.2813	0.3125	●	●	2.500	0.5626	●	●	3.000	0.8439
GSX Δ 20S- Δ D	5/16	0.3125	0.3125	●	●	2.500	0.6250	●	●	3.000	0.9375
GSX Δ 24S- Δ D	3/8	0.3750	0.3750	●	●	3.000	0.7500	●	●	3.500	1.1250
GSX Δ 28S- Δ D	7/16	0.4375	0.4375	●	●	3.000	0.8750	●	●	3.500	1.3125
GSX Δ 32S- Δ D	1/2	0.5000	0.5000	●	●	3.000	1.0000	●	●	3.500	1.5000
GSX Δ 36S- Δ D	9/16	0.5625	0.5625	●	●	3.500	1.1250	●	●	4.500	1.6875
GSX Δ 40S- Δ D	5/8	0.6250	0.6250	●	●	3.500	1.2500	●	●	4.500	1.8750
GSX Δ 44S- Δ D	11/16	0.6875	0.6875	●	●	4.000	1.3750	●	●	4.500	2.0625
GSX Δ 48S- Δ D	3/4	0.7500	0.7500	●	●	4.000	1.5000	●	●	5.000	2.2500
GSX Δ 56S- Δ D	7/8	0.8750	0.8750	●	●	4.000	1.7500	●	●	5.000	2.6250
GSX Δ 64S- Δ D	1	1.0000	1.0000	●	●	4.000	2.0000	●	●	5.500	3.0000

●: USA stock standard

GSX Endmills - Gash Land (C) INCH Lineup

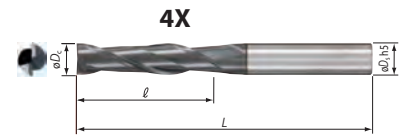
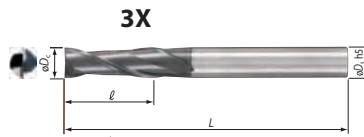
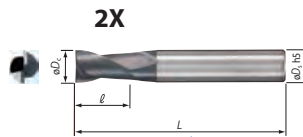
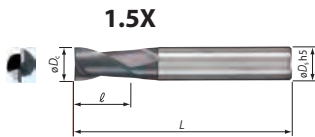

Gash Land (C)	Diameter ϕD_c		Shank Diameter ϕD_s (Inch)	1.5			2			3			4						
	Fraction	Inch		Flute		OAL L (Inch)	Flute Length ℓ (Inch)	Flute		OAL L (Inch)	Flute Length ℓ (Inch)	Flute		OAL L (Inch)	Flute Length ℓ (Inch)				
				2	4			2	4			2	4			2	4		
GSX Δ 04C- Δ D	1/16	0.0625	0.1250	●	●	1.500	0.0938	●	●	1.500	0.1250	●	●	1.500	0.1875	●	●	1.500	0.2500
GSX Δ 06C- Δ D	3/32	0.0938	0.1250	●	●	1.500	0.1406	●	●	1.500	0.1875	●	●	1.500	0.2813	●	●	1.500	0.3750
GSX Δ 08C- Δ D	1/8	0.1250	0.1250	●	●	2.000	0.1875	●	●	2.000	0.2500	●	●	2.000	0.3750	●	●	2.000	0.5000
GSX Δ 10C- Δ D	5/32	0.1563	0.1875	●	●	2.000	0.2344	●	●	2.000	0.3125	●	●	2.000	0.4688	●	●	2.000	0.6250
GSX Δ 12C- Δ D	3/16	0.1875	0.1875	●	●	2.000	0.2813	●	●	2.000	0.3750	●	●	2.000	0.5625	●	●	2.500	0.7500
GSX Δ 14C- Δ D	7/32	0.2188	0.2500	●	●	2.000	0.3282	●	●	2.000	0.4376	●	●	2.000	0.6564	●	●	2.500	0.8752
GSX Δ 16C- Δ D	1/4	0.2500	0.2500	●	●	2.000	0.3750	●	●	2.000	0.5000	●	●	2.000	0.7500	●	●	2.500	1.0000
GSX Δ 18C- Δ D	9/32	0.2813	0.3125	●	●	2.500	0.4219	●	●	2.500	0.5626	●	●	3.000	0.8439	●	●	3.000	1.1252
GSX Δ 20C- Δ D	5/16	0.3125	0.3125	●	●	2.500	0.4688	●	●	2.500	0.6250	●	●	3.000	0.9375	●	●	3.000	1.2500
GSX Δ 24C- Δ D	3/8	0.3750	0.3750	●	●	3.000	0.5625	●	●	3.000	0.7500	●	●	3.500	1.1250	●	●	3.500	1.5000
GSX Δ 28C- Δ D	7/16	0.4375	0.4375	●	●	3.000	0.6563	●	●	3.000	0.8750	●	●	3.500	1.3125	●	●	4.000	1.7500
GSX Δ 32C- Δ D	1/2	0.5000	0.5000	●	●	3.000	0.7500	●	●	3.000	1.0000	●	●	3.500	1.5000	●	●	4.000	2.0000
GSX Δ 36C- Δ D	9/16	0.5625	0.5625	●	●	3.500	0.8438	●	●	3.500	1.1250	●	●	4.500	1.6875	●	●	5.000	2.2500
GSX Δ 40C- Δ D	5/8	0.6250	0.6250	●	●	3.500	0.9375	●	●	3.500	1.2500	●	●	4.500	1.8750	●	●	5.000	2.5000
GSX Δ 44C- Δ D	11/16	0.6875	0.6875	●	●	4.000	1.0313	●	●	4.000	1.3750	●	●	4.500	2.0625	●	●	5.000	2.7500
GSX Δ 48C- Δ D	3/4	0.7500	0.7500	●	●	4.000	1.1250	●	●	4.000	1.5000	●	●	5.000	2.2500	●	●	5.500	3.0000
GSX Δ 56C- Δ D	7/8	0.8750	0.8750	●	●	4.000	1.3125	●	●	4.000	1.7500	●	●	5.000	2.6250	●	●	5.500	3.5000
GSX Δ 64C- Δ D	1	1.0000	1.0000	●	●	4.000	1.5000	●	●	4.000	2.0000	●	●	5.500	3.0000	●	●	6.000	4.0000

●: USA stock standard



GSX Endmills - Sharp Edge (S) METRIC Lineup

2X

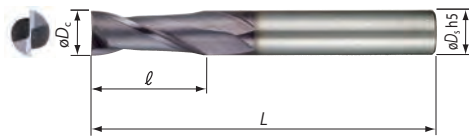

3X

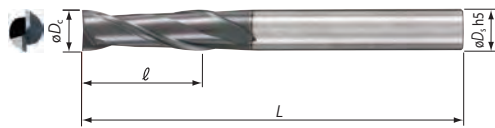

■ Endmill Identification (GSXMILL Series Only)



- 1 Series Code
- 2 No. of Flutes
- 3 Diameter x 100
- 4 Cutting Edge
- 5 Cutting Edge Length

Sharp Edge (S)	Diameter φD _C (mm)	Shank Diameter φD _S (mm)	2				3			
			Flute		OAL L (mm)	Flute Length ℓ (mm)	Flute		OAL L (mm)	Flute Length ℓ (mm)
			2	4			2	4		
GSXΔ0050S-AD	0.5	4.0	*		40.0	1.3	*		40.0	1.5
GSXΔ0100S-AD	1.0	4.0	*	*	40.0	2.5	*	*	40.0	3.0
GSXΔ0150S-AD	1.5	3.0	*	*	40.0	3.8	*		40.0	4.5
GSXΔ0150S-AD-S3	1.5	4.0	*	*	38.0	3.8				
GSXΔ0200S-AD	2.0	4.0	*	*	40.0	5.0	*	*	40.0	6.0
GSXΔ0200S-AD-S3	2.0	3.0	*	*	38.0	5.0				
GSXΔ0250S-AD	2.5	4.0	*	*	40.0	6.3	*		40.0	7.5
GSXΔ0300S-AD	3.0	6.0	*	*	45.0	7.5	*	*	50.0	9.0
GSXΔ0300S-AD-S3	3.0	3.0	*	*	38.0	7.5				
GSXΔ0350S-AD	3.5	6.0	*	*	45.0	8.8				
GSXΔ0400S-AD	4.0	6.0	*	*	45.0	11.0	*	*	50.0	12.0
GSXΔ0400S-AD-S3	4.0	4.0	*	*	45.0	11.0				
GSXΔ0450S-AD	4.5	6.0	*	*	50.0	11.3				
GSXΔ0500S-AD	5.0	6.0	*	*	50.0	13.0	*	*	50.0	15.0
GSXΔ0550S-AD	5.5	6.0	*	*	50.0	13.0				
GSXΔ0600S-AD	6.0	6.0	*	*	50.0	13.0	*	*	50.0	18.0
GSXΔ0700S-AD	7.0	8.0	*	*	60.0	16.0		*	70.0	21.0
GSXΔ0800S-AD	8.0	8.0	*	*	60.0	19.0	*	*	70.0	24.0
GSXΔ0900S-AD	9.0	10.0	*	*	70.0	19.0				
GSXΔ1000S-AD	10.0	10.0	*	*	70.0	22.0	*	*	90.0	30.0
GSXΔ1200S-AD	12.0	12.0	*	*	75.0	26.0	*	*	90.0	36.0
GSXΔ1600S-AD	16.0	16.0	*	*	90.0	32.0	*	*	110.0	48.0
GSXΔ2000S-AD	20.0	20.0	*	*	100.0	40.0				

* - World Wide Warehouse Item

GSX Endmills - Gash Land (C) METRIC Lineup

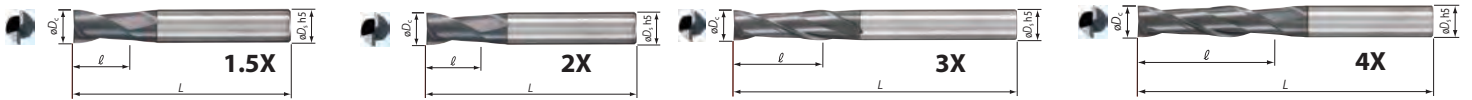



Gash Land (C)	Diameter φD _C (mm)	Shank Diameter φD _S (mm)	1.5				2				3				4							
			Flute		OAL L (mm)	Flute Length ℓ (mm)	Flute		OAL L (mm)	Flute Length ℓ (mm)	Flute		OAL L (mm)	Flute Length ℓ (mm)	Flute	OAL L (mm)	Flute Length ℓ (mm)	Flute Length ℓ (mm)				
			2	4			2	4			2	4							2	4		
GSXΔ0050C-AD	0.5	4.0					*		40.0	1.0												
GSXΔ0100C-AD	1.0	4.0	*	*	40.0	1.5	*	*	40.0	2.0	*	*	40.0	3.0	*	*	40.0	4.0	*	40.0	1.5	2.5
GSXΔ0150C-AD	1.5	4.0	*	*	40.0	2.3	*	*	40.0	3.0	*	*	40.0	4.5	*	*	40.0	6.0	*	40.0	2.3	3.8
GSXΔ0200C-AD	2.0	4.0	*	*	40.0	3.0	*	*	40.0	4.0	*	*	40.0	6.0	*	*	40.0	8.0	*	40.0	3.0	5.0
GSXΔ0250C-AD	2.5	4.0	*	*	40.0	3.8	*	*	40.0	5.0	*	*	40.0	7.5	*	*	50.0	10.0	*	40.0	3.8	6.3
GSXΔ0300C-AD	3.0	6.0	*	*	45.0	4.5	*	*	45.0	6.0	*	*	50.0	9.0	*	*	50.0	16.0	*	45.0	4.5	7.5
GSXΔ0350C-AD	3.5	6.0	*	*	45.0	5.3	*	*	45.0	7.0												
GSXΔ0400C-AD	4.0	6.0	*	*	45.0	6.0	*	*	45.0	8.0	*	*	50.0	12.0	*	*	50.0	20.0	*	45.0	6.0	11.0
GSXΔ0450C-AD	4.5	6.0	*	*	50.0	6.8	*	*	50.0	9.0												
GSXΔ0500C-AD	5.0	6.0	*	*	50.0	7.5	*	*	50.0	10.0	*	*	50.0	15.0	*	*	60.0	24.0	*	50.0	7.5	11.0
GSXΔ0550C-AD	5.5	6.0	*	*	50.0	9.3	*	*	50.0	11.0												
GSXΔ0600C-AD	6.0	6.0	*	*	50.0	9.0	*	*	50.0	12.0	*	*	50.0	18.0	*	*	60.0	24.0	*	50.0	9.0	13.0
GSXΔ0700C-AD	7.0	8.0	*	*	60.0	11.0	*	*	60.0	14.0							*	60.0	11.0	60.0	11.0	13.0
GSXΔ0800C-AD	8.0	8.0	*	*	60.0	12.0	*	*	60.0	16.0	*	*	70.0	24.0	*	*	80.0	32.0	*	60.0	12.0	19.0
GSXΔ0900C-AD	9.0	10.0	*	*	70.0	14.0	*	*	70.0	18.0							*	70.0	14.0	70.0	14.0	19.0
GSXΔ1000C-AD	10.0	10.0	*	*	70.0	15.0	*	*	70.0	20.0	*	*	90.0	30.0	*	*	90.0	40.0	*	70.0	15.0	22.0
GSXΔ1200C-AD	12.0	12.0	*	*	75.0	18.0	*	*	75.0	24.0	*	*	90.0	36.0	*	*	100.0	48.0	*	75.0	18.0	26.0
GSXΔ1600C-AD	16.0	16.0					*	*	90.0	32.0	*	*	110.0	48.0	*	*	120.0	64.0				
GSXΔ2000C-AD	20.0	20.0					*	*	100.0	40.0												
GSXΔ2500C-AD	25.0	25.0					*	*	120.0	50.0												

* - World Wide Warehouse Item



Product Range - GSXB Ballnose Endmills

GSXB Endmills	
Application	Inch
General Purpose	GSXB200
	
	$\phi 1/16'' - \phi 1''$
	Metric
General Purpose	GSXB2000
	
	$\phi 0.4\text{mm} - \phi 20\text{mm}$



Endmill Series

Recommended Cutting Conditions - GSXB

Speeds and Feeds reflect roughing and finishing applications

Recommended Cutting Conditions

1. If cutting noise and vibration are present, please change the cutting conditions accordingly.
2. If the machine is not designed to achieve the recommended spindle speed, please use the max. spindle speed available.

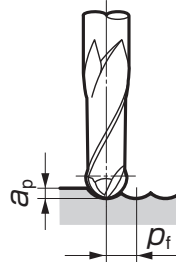

Radius Milling

Work Material	Carbon Steel, Alloy Steel (Below 25HRC)		Carbon Steel, Alloy Steel (Below 50HRC)		Cast Iron Special Cast Iron		Stainless Steel Titanium Alloy	
	Spindle Speed (SFM)	Feed Rate (in/min)	Spindle Speed (SFM)	Feed Rate (in/min)	Spindle Speed (SFM)	Feed Rate (in/min)	Spindle Speed (SFM)	Feed Rate (in/min)
0.0313	200 - 450	98	100 - 400	53	210 - 550	98	120 - 400	82
0.0469		118		62		118		98
0.0625		118		65		126		98
0.0781		118		67		153		98
0.0938		118		67		153		98
0.1094		118		67		153		98
0.1250		149		82		161		106
0.1407		169		86		181		98
0.1563		185		98		208		98
0.1875		165		82		177		86
0.2188		137		75		157		75
0.2500		110		59		130		59
0.2813		94		49		110		49
0.3125		82		43		94		43
0.3438		70		37		82		37
0.3750		63		33		74		34
0.4375	57	29	67	29				
0.5000	45	24	53	24				
Standard Depth-of-cut	a_p	$0.02 \times D_c$	$0.02 \times D_c$	$0.02 \times D_c$	$0.02 \times D_c$	$0.02 \times D_c$	$0.02 \times D_c$	$0.02 \times D_c$
	p_f	$0.05 \times D_c$	$0.05 \times D_c$	$0.05 \times D_c$	$0.05 \times D_c$	$0.05 \times D_c$	$0.05 \times D_c$	$0.05 \times D_c$





Recommended Milling Examples

Application	Radius Milling		Copy Milling		Pocket Milling	
	Roughing	Finishing	Roughing	Finishing	Roughing	Finishing
Ballnose Type	⊙	⊙	⊙	⊙	⊙	⊙

Diameter



Application Range

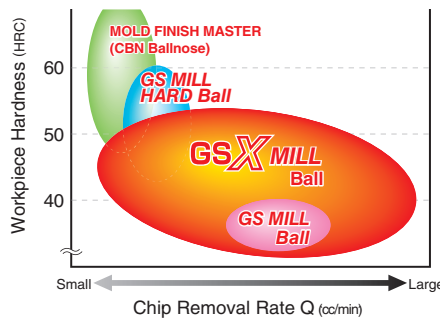

Reduced Cutting Resistance

Large helix angle on cutting edge reduces cutting resistance.

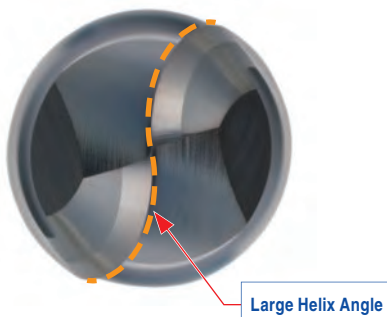

Improved Chip Evacuation

Unique pocket design and expanded pocket area promotes better chip evacuation.

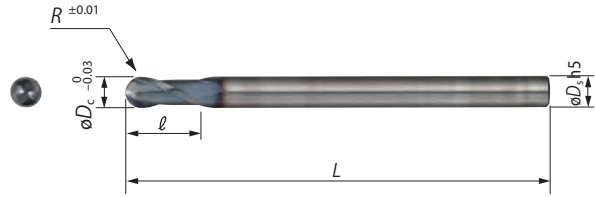
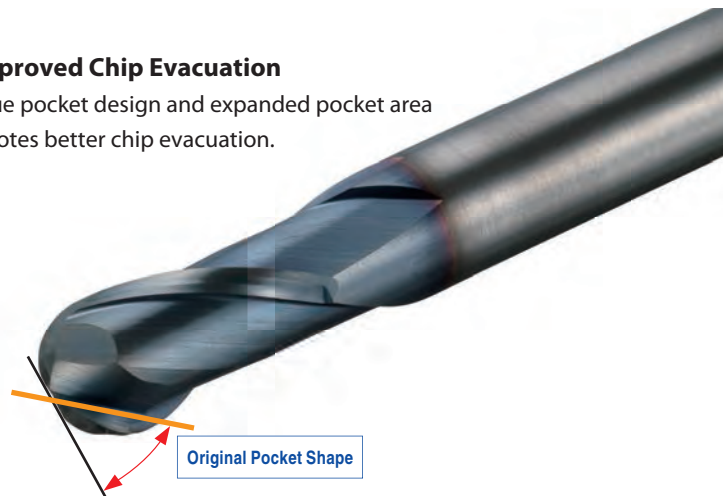

Ballnose (B)	Stock	φD _c Inch	φD _c mm	φD _s Inch & mm	L Inch & mm	ℓ Inch & mm	R Inch & mm
GSXB204	●	0.063	1.588	0.1250	2.000	0.0938	0.0313
GSXB206	●	0.094	2.381	0.1250	2.500	0.1406	0.0469
GSXB208	●	0.125	3.175	0.1250	2.500	0.1875	0.0625
GSXB210	●	0.156	3.969	0.1875	3.000	0.2344	0.0781
GSXB212	●	0.188	4.763	0.1875	3.000	0.2813	0.0938
GSXB214	●	0.219	5.558	0.2500	3.000	0.3282	0.1094
GSXB216	●	0.250	6.350	0.2500	3.000	0.3750	0.1250
GSXB218	●	0.281	7.144	0.3125	3.500	0.4220	0.1407
GSXB220	●	0.313	7.938	0.3125	3.500	0.4688	0.1563
GSXB224	●	0.375	9.525	0.3750	4.000	0.5652	0.1875
GSXB228	●	0.438	11.113	0.4375	4.000	0.6563	0.2188
GSXB232	●	0.500	12.700	0.5000	4.500	0.7500	0.2500
GSXB236	●	0.563	14.288	0.5625	4.500	0.8438	0.2813
GSXB240	●	0.625	15.875	0.6250	5.500	0.9375	0.3125
GSXB244	●	0.688	17.463	0.6875	5.500	1.0313	0.3438
GSXB248	●	0.750	19.050	0.7500	6.000	1.1250	0.3750
GSXB256	●	0.875	22.225	0.8750	6.500	1.3125	0.4375
GSXB264	●	1.000	25.400	1.0000	7.000	1.5000	0.5000
GSXB20020	★	.0158	0.4	4	50	0.6	0.20
GSXB20030	★	.0237	0.6	4	50	0.9	0.30
GSXB20050	★	.0394	1.0	4	50	1.5	0.50
GSXB20075	★	.0591	1.5	4	50	2.3	0.75
GSXB20100	★	.0788	2.0	6	60	3.0	1.00
GSXB20125	★	.0985	2.5	6	60	4.0	1.25
GSXB20150	★	.1182	3.0	6	60	4.5	1.50
GSXB20200	★	.1575	4.0	6	70	6.0	2.00
GSXB20250	★	.1969	5.0	6	80	7.5	2.50
GSXB20300	★	.2363	6.0	6	80	9.0	3.00
GSXB20350	★	.2756	7.0	8	90	11.0	3.50
GSXB20400	★	.3150	8.0	8	90	12.0	4.00
GSXB20500	★	.3937	10.0	10	100	15.0	5.00
GSXB20600	★	.4725	12.0	12	110	18.0	6.00
GSXB20700	★	.5512	14.0	16	110	21.0	7.00
GSXB20800	★	.6300	16.0	16	140	24.0	8.00
GSXB20900	★	.7087	18.0	20	140	27.0	9.00
GSXB21000	★	.7874	20.0	20	160	30.0	10.00

★ - World Wide Warehouse Item ● - USA stock standard



Product Range - GSXVL Anti-vibration Type

GSXVL Endmills	
Application	Radius Type
General Purpose	GSXVL4000-R02-2.5D  φ3mm - φ 25mm
	Square Type 
	φ2mm - φ 25mm



Endmill Series

Recommended Cutting Conditions - GSXVL

Speeds and Feeds reflect roughing and finishing applications

ISO	GSXVL Endmills			Cutting Diameter											
	Material	Hardness (Bhn)	SFM	1/8	3/16	1/4	5/16	3/8	7/16	1/2	9/16	5/8	3/4	1	
				Feed/Tooth	Feed/Tooth	Feed/Tooth	Feed/Tooth	Feed/Tooth	Feed/Tooth	Feed/Tooth	Feed/Tooth	Feed/Tooth	Feed/Tooth	Feed/Tooth	Feed/Tooth
P	Low and Medium Carbon Steels	<250	200-450	.0005-.003	.0007-.0033	.0008-.0036	.0008-.0039	.001-.0042	.0012-.0055	.0014-.0066	.0016-.0085	.002-.0105	.002-.0118	.002-.0125	
	Medium Carbon Alloy Steels	<250	200-425	.0005-.003	.0007-.0033	.0008-.0035	.0008-.0038	.001-.0042	.0012-.0055	.0014-.0066	.0016-.0085	.002-.0105	.002-.0118	.002-.0125	
	Medium-High Carbon Steels	>250	175-350	.0005-.0027	.0007-.003	.0008-.0033	.0008-.0036	.001-.0042	.0012-.0045	.0014-.0066	.0016-.007	.002-.0079	.002-.0089	.002-.011	
	Free Machining Steels and Alloys	<250	200-375	.0005-.003	.0008-.0033	.0008-.0035	.0008-.0039	.001-.0042	.0012-.0055	.0014-.0066	.0016-.008	.002-.0088	.002-.0099	.002-.011	
	Tool Steels	<250	150-350	.0005-.003	.0005-.0033	.0008-.0035	.0008-.0039	.001-.0042	.001-.0055	.0012-.0066	.0016-.008	.002-.0088	.002-.0099	.002-.011	
M	Stainless Steel	Martensitic and Ferritic	250-350	100-275	.0005-.0025	.0005-.0028	.0008-.0031	.0008-.0034	.001-.0036	.001-.0044	.0012-.0055	.0013-.0067	.0015-.0077	.002-.0081	.002-.0095
		Austenitic	>350	75-175	.0005-.002	.0005-.0023	.0006-.0026	.0008-.0029	.0008-.0031	.0008-.0033	.001-.0036	.001-.0042	.001-.0047	.0015-.0055	.002-.0065
			<250	150-375	.0005-.0025	.0005-.0028	.0005-.0031	.0008-.0033	.0008-.0036	.001-.0035	.001-.004	.001-.0046	.001-.0055	.001-.0065	.001-.0075
K	Grey Cast Iron	Ductile Iron	<250	150-350	.0005-.0025	.0005-.0028	.0008-.0031	.001-.0033	.001-.0037	.0011-.0042	.0012-.0049	.0012-.0055	.0014-.0061	.0015-.0068	.002-.0075
			<280	90-325	.0005-.0022	.0005-.0025	.0008-.0028	.001-.0031	.001-.0033	.001-.0035	.001-.0038	.001-.0041	.001-.0048	.001-.0055	.001-.0065
S	Exotic Alloys: Inconel, Hastalloy, Waspalloy, etc.	Ductile Iron	250-550		.0008-.003	.001-.0033	.001-.0035	.001-.0037	.001-.004	.001-.0053	.001-.0062	.001-.007	.001-.0076	.001-.0089	.001-.0105
			175-350		.0005-.003	.0005-.0033	.0008-.0035	.001-.0037	.001-.004	.001-.0053	.001-.0062	.001-.007	.001-.0076	.001-.0089	.001-.0105
N	Non-Ferrous Material		600-1500		.001-.003	.001-.0033	.001-.0033	.001-.0038	.001-.0045	.001-.0055	.001-.007	.001-.008	.001-.0115	.001-.0125	



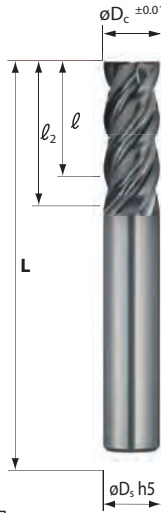

Endmill Series

Recommended Milling Examples

Application	Side Milling		Groove Milling		Groove Finishing	
	Roughing	Finishing	Roughing	Finishing	Roughing	Finishing
Square Type	⊙	○	⊙	⊙	⊙	○
Radius Type	⊙	○	⊙	⊙	⊙	○

Diameter

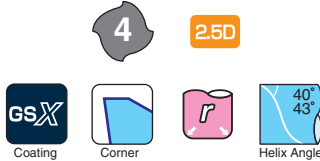
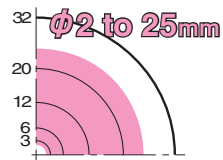

Irregular Pitch and Irregular Lead

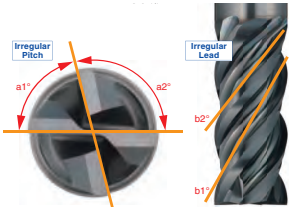

Drastically Improved Surface Quality

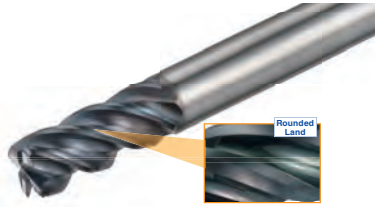

Catalog No. R- Radius S- Square	Stock	Type	ϕD_c mm	ϕD_c mm	ℓ mm	ℓ_2 mm	L mm	Corner Radius
GSXVL4030-R02-2.5D	★	R	3.0	6	8.0	9.5	50	0.2
GSXVL4030-R05-2.5D	★	R	3.0	6	8.0	9.5	50	0.5
GSXVL4040-R02-2.5D	★	R	4.0	6	10.0	11.5	50	0.2
GSXVL4040-R05-2.5D	★	R	4.0	6	10.0	11.5	50	0.5
GSXVL4040-R10-2.5D	★	R	4.0	6	10.0	11.5	50	1.0
GSXVL4050-R02-2.5D	★	R	5.0	6	13.0	14.5	60	0.2
GSXVL4050-R05-2.5D	★	R	5.0	6	13.0	14.5	60	0.5
GSXVL4050-R10-2.5D	★	R	5.0	6	13.0	14.5	60	1.0
GSXVL4060-R03-2.5D	★	R	6.0	6	15.0	-	60	0.3
GSXVL4060-R05-2.5D	★	R	6.0	6	15.0	-	60	0.5
GSXVL4060-R10-2.5D	★	R	6.0	6	15.0	-	60	1.0
GSXVL4060-R15-2.5D	★	R	6.0	6	15.0	-	60	1.5
GSXVL4080-R03-2.5D	★	R	8.0	8	20.0	-	80	0.3
GSXVL4080-R05-2.5D	★	R	8.0	8	20.0	-	80	0.5
GSXVL4080-R10-2.5D	★	R	8.0	8	20.0	-	80	1.0
GSXVL4080-R15-2.5D	★	R	8.0	8	20.0	-	80	1.5
GSXVL4080-R20-2.5D	★	R	8.0	8	20.0	-	80	2.0
GSXVL4100-R03-2.5D	★	R	10.0	10	25.0	-	90	0.3
GSXVL4100-R05-2.5D	★	R	10.0	10	25.0	-	90	0.5
GSXVL4100-R10-2.5D	★	R	10.0	10	25.0	-	90	1.0
GSXVL4100-R15-2.5D	★	R	10.0	10	25.0	-	90	1.5
GSXVL4100-R20-2.5D	★	R	10.0	10	25.0	-	90	2.0
GSXVL4120-R05-2.5D	★	R	12.0	12	30.0	-	90	0.5
GSXVL4120-R10-2.5D	★	R	12.0	12	30.0	-	90	1.0
GSXVL4120-R15-2.5D	★	R	12.0	12	30.0	-	90	1.5
GSXVL4120-R20-2.5D	★	R	12.0	12	30.0	-	90	2.0
GSXVL4120-R30-2.5D	★	R	12.0	12	30.0	-	90	3.0
GSXVL4160-R10-2.5D	★	R	16.0	16	40.0	-	115	1.0
GSXVL4160-R15-2.5D	★	R	16.0	16	40.0	-	115	1.5
GSXVL4160-R20-2.5D	★	R	16.0	16	40.0	-	115	2.0
GSXVL4160-R30-2.5D	★	R	16.0	16	40.0	-	115	3.0
GSXVL4200-R10-2.5D	★	R	20.0	20	50.0	-	125	1.0
GSXVL4200-R15-2.5D	★	R	20.0	20	50.0	-	125	1.5
GSXVL4200-R20-2.5D	★	R	20.0	20	50.0	-	125	2.0
GSXVL4200-R30-2.5D	★	R	20.0	20	50.0	-	125	3.0
GSXVL4250-R10-2.5D	★	R	25.0	25	63.0	-	140	1.0
GSXVL4250-R15-2.5D	★	R	25.0	25	63.0	-	140	1.5
GSXVL4250-R20-2.5D	★	R	25.0	25	63.0	-	140	2.0
GSXVL4250-R30-2.5D	★	R	25.0	25	63.0	-	140	3.0
GSXVL4020-2.5D	★	S	2.0	4	5.0	6.5	50	-
GSXVL4030-2.5D	★	S	3.0	6	8.0	9.5	50	-
GSXVL4040-2.5D	★	S	4.0	6	10.0	11.5	50	-
GSXVL4050-2.5D	★	S	5.0	6	13.0	14.5	60	-
GSXVL4060-2.5D	★	S	6.0	6	15.0	-	60	-
GSXVL4070-2.5D	★	S	7.0	8	18.0	20.0	70	-
GSXVL4080-2.5D	★	S	8.0	8	20.0	-	80	-
GSXVL4090-2.5D	★	S	9.0	10	23.0	25.0	90	-
GSXVL4100-2.5D	★	S	10.0	10	25.0	-	90	-
GSXVL4110-2.5D	★	S	11.0	12	28.0	30.5	90	-
GSXVL4120-2.5D	★	S	12.0	12	30.0	-	90	-
GSXVL4140-2.5D	★	S	14.0	16	35.0	37.5	110	-
GSXVL4150-2.5D	★	S	15.0	16	38.0	41.0	110	-
GSXVL4160-2.5D	★	S	16.0	16	40.0	-	115	-
GSXVL4180-2.5D	★	S	18.0	20	45.0	48.0	120	-
GSXVL4200-2.5D	★	S	20.0	20	50.0	-	125	-
GSXVL4250-2.5D	★	S	25.0	25	63.0	-	140	-

★ - World Wide Warehouse Item

Performance Data

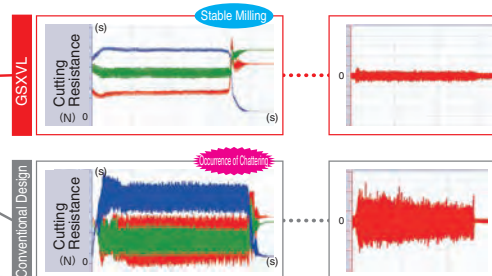
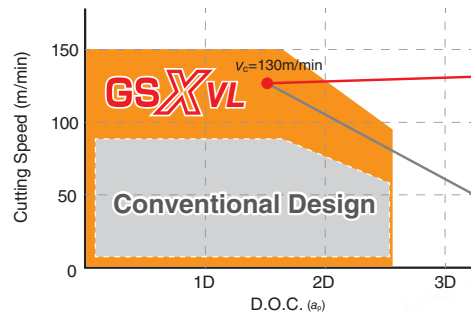

● Side Milling
Work Material: S50C Tool diameter: $\phi 10$
Cutting Conditions: $n=4,100\text{min}^{-1}$
 $V_f=1,450\text{mm/min}$
 $a_p=15\text{mm}$, $a_e=2\text{mm}$, Wet
Machine: BT50



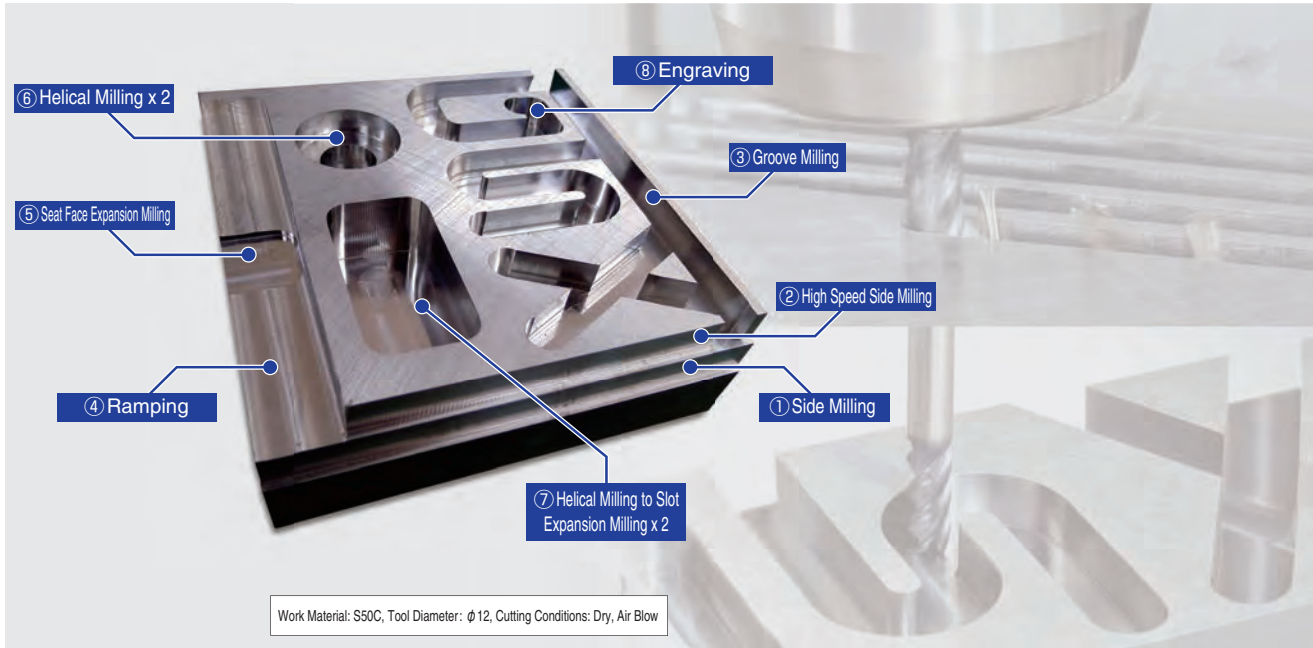

① Side Milling

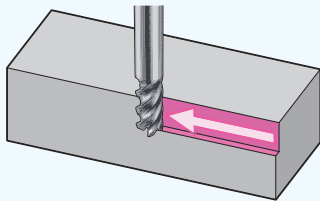

Cutting Conditions: $v_c=102\text{m/min}$ ($n=4,100\text{min}^{-1}$)
 $v_f=1,080\text{mm/min}$ (0.1mm/t)
 $a_p=24\text{mm}$, $a_e=2.0\text{mm}$

② High Speed Side Milling

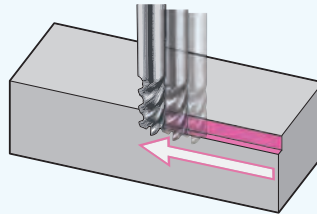

Cutting Conditions: $v_c=151\text{m/min}$ ($n=4,000\text{min}^{-1}$)
 $v_f=4,800\text{mm/min}$ (0.3mm/t)
 $a_p=12\text{mm}$, $a_e=2.0\text{mm}$

③ Groove Milling

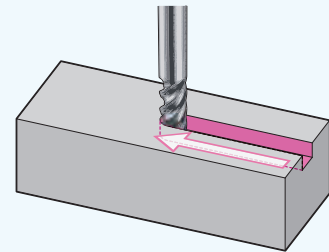

Cutting Conditions: $v_c=90\text{m/min}$ ($n=2,400\text{min}^{-1}$)
 $v_f=960\text{mm/min}$ (0.1mm/t)
 $a_p=12\text{mm}$

④ Ramping

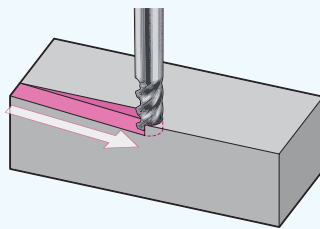

Cutting Conditions: $v_c=90\text{m/min}$ ($n=2,400\text{min}^{-1}$)
 $v_f=480\text{mm/min}$ (0.05mm/t)
Ramp Angle 5°

⑤ Seat Face Expansion Milling

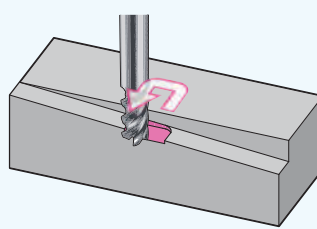

Cutting Conditions: $v_c=90\text{m/min}$ ($n=2,400\text{min}^{-1}$)
 $v_f=960\text{mm/min}$ (0.1mm/t)

⑥ Helical Milling x 2

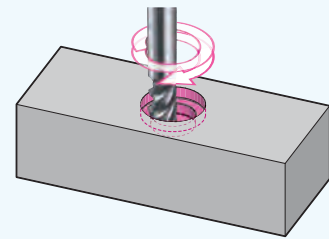

Cutting Conditions: $v_c=90\text{m/min}$ ($n=2,400\text{min}^{-1}$)
 $v_f=480\text{mm/min}$ (0.05mm/t)
Ramp Angle 3°

⑦ Helical Milling to Slot Expansion Milling x 2

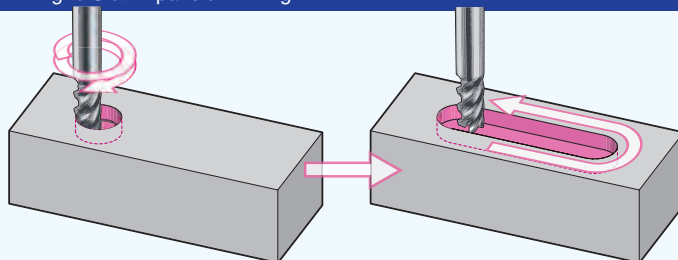

Cutting Conditions: $v_c=90\text{m/min}$ ($n=2,400\text{min}^{-1}$)
[Helical] $v_f=480\text{mm/min}$ (0.05mm/t) [Slot Expansion] $v_f=672\text{mm/min}$ (0.07mm/t) [Finishing] $v_f=1,920\text{mm/min}$ (0.2mm/t)
Ramp Angle 3°
 $a_p=24\text{mm}$, $a_e=0.1\text{mm}$

⑧ Engraving

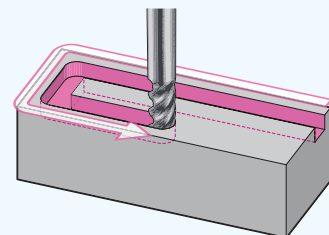

Cutting Conditions: $v_c=79\text{m/min}$ ($n=2,100\text{min}^{-1}$)
 $v_f=588\text{mm/min}$ (0.07mm/t)
 $a_p=12\text{mm}$

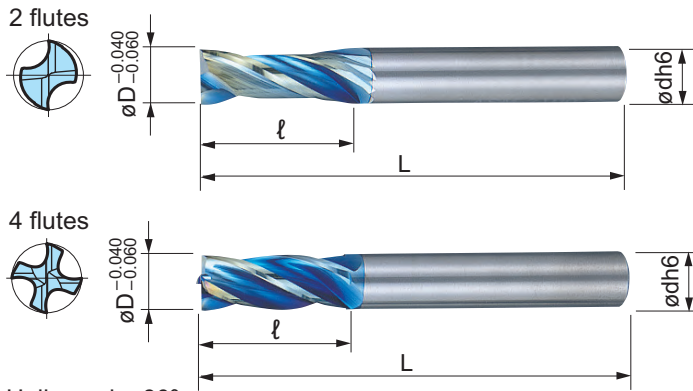

Helix angle: 30°
 Corner: Sharp edge
 Dia. Range: $\varnothing 2\sim 16\text{mm}$

Features & Benefits

- Very smooth AURORA COAT provides low adhesion and good surface finish in non-ferrous alloys.
- With lower cutting forces and rigidity, this series is suitable for low rigidity machines.
- Available in two and four flutes in both square and ballnose type endmills (see page 437 for SNB Series Ballnose.)

Endmill Series

Two Flutes - METRIC					
Catalog No.	Stock	Cutter Dia.d \varnothing	Shank Dia.D \varnothing	Flute Length ℓ	Overall Length L
ASM2020DL	★	2.0mm	4.0mm	6.0mm	40.0mm
ASM2030DL	★	3.0mm	6.0mm	10.0mm	45.0mm
ASM2040DL	★	4.0mm	6.0mm	12.0mm	45.0mm
ASM2050DL	★	5.0mm	6.0mm	15.0mm	50.0mm
ASM2060DL	★	6.0mm	6.0mm	15.0mm	50.0mm
ASM2080DL	★	8.0mm	8.0mm	18.0mm	60.0mm
ASM2100DL	★	10.0mm	10.0mm	22.0mm	71.0mm
ASM2120DL	★	12.0mm	12.0mm	25.0mm	75.0mm
ASM2160DL	★	16.0mm	16.0mm	32.0mm	90.0mm

Grade: DL1000

Four Flutes - METRIC					
Catalog No.	Stock	Cutter Dia.d \varnothing	Shank Dia.D \varnothing	Flute Length ℓ	Overall Length L
ASM4020DL	★	2.0mm	4.0mm	6.0mm	40.0mm
ASM4030DL	★	3.0mm	6.0mm	10.0mm	45.0mm
ASM4040DL	★	4.0mm	6.0mm	12.0mm	45.0mm
ASM4050DL	★	5.0mm	6.0mm	15.0mm	50.0mm
ASM4060DL	★	6.0mm	6.0mm	15.0mm	50.0mm
ASM4080DL	★	8.0mm	8.0mm	18.0mm	60.0mm
ASM4100DL	★	10.0mm	10.0mm	22.0mm	71.0mm
ASM4120DL	★	12.0mm	12.0mm	25.0mm	75.0mm
ASM4160DL	★	16.0mm	16.0mm	32.0mm	90.0mm

Grade: DL1000

Recommended Running Conditions

Radius mm	Aluminum Alloy							
	Wet (Emulsion)				Dry			
	Side Milling (4 flute)		Groove Milling (2 flute)		Side Milling (4 flute)		Groove Milling (2 flute)	
	RPM	Feed Rate mm/min. (ipt)	RPM	Feed Rate mm/min. (ipt)	RPM	Feed Rate mm/min. (ipt)	RPM	Feed Rate mm/min. (ipt)
2	40,000	1,400 (55)	28,000	280 (11)	40,000	980 (38)	28,000	200 (7)
3	32,000	2,000 (80)	22,000	400 (16)	32,000	1,400 (55)	22,000	280 (11)
4	26,000	2,600 (102)	18,000	520 (20)	26,000	1,800 (70)	18,000	360 (14)
5	20,000	2,600 (102)	14,000	520 (20)	20,000	1,800 (70)	14,000	360 (14)
6	17,000	2,700 (106)	12,000	540 (21)	17,000	1,900 (74)	12,000	370 (14)
8	13,000	2,700 (106)	9,000	540 (21)	13,000	1,900 (74)	9,000	370 (14)
10	11,000	2,800 (110)	7,200	560 (22)	11,000	2,000 (80)	7,200	390 (15)
12	8,500	2,800 (110)	6,000	560 (22)	8,500	2,000 (80)	6,000	390 (15)
16	6,400	2,800 (110)	4,500	560 (22)	6,400	2,000 (80)	4,500	390 (15)
D.O.C.	Ad	1.5D		1.0D		1.5D		0.5D
	Pf	0.2D		1.0D		0.2D		1.0D

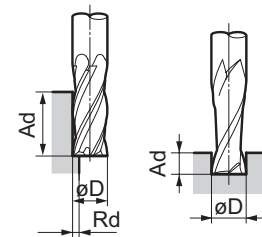

- For groove milling of stainless steel, use 60% recommended RPM and 40% feed rate.
- If cutting noise and vibration occur, please reduce the cutting speed accordingly.



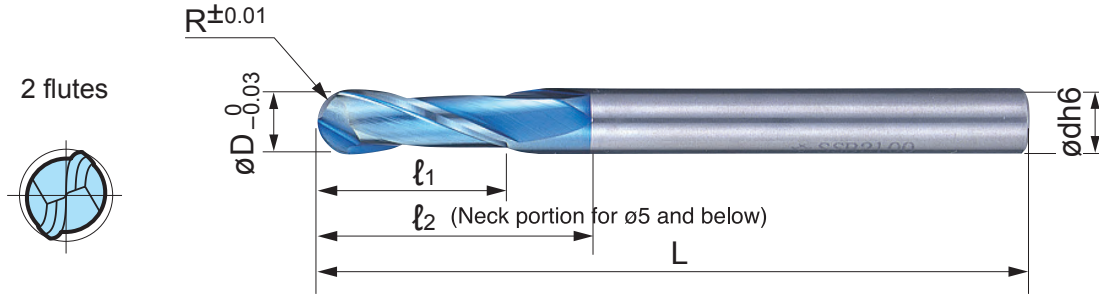

Helix angle :30°

Two Flutes - METRIC							
Sumitomo Catalog No.	Stock	R	øD	ℓ ₁	ℓ ₂	L	ød
SNB2020DL	★	1.0mm	2.0mm	3.0mm	5.0mm	60mm	6.0mm
SNB2030DL	★	1.5mm	3.0mm	4.5mm	8.0mm	80mm	6.0mm
SNB2040DL	★	2.0mm	4.0mm	6.0mm	12.0mm	80mm	6.0mm
SNB2050DL	★	2.5mm	5.0mm	7.5mm	14.0mm	90mm	6.0mm
SNB2060DL	★	3.0mm	6.0mm	9.0mm	-	100mm	6.0mm
SNB2080DL	★	4.0mm	8.0mm	12.0mm	-	100mm	8.0mm
SNB2100DL	★	5.0mm	10.0mm	15.0mm	-	120mm	10.0mm
SNB2120DL	★	6.0mm	12.0mm	18.0mm	-	120mm	12.0mm
SNB2160DL	★	8.0mm	16.0mm	24.0mm	-	160mm	16.0mm

Grade: DL1200

Recommended Running Conditions

Radius. mm	Aluminum Alloy			
	Wet (Emulsion)		Dry	
	RPM	Feed Rate mm/min. (ipt)	RPM	Feed Rate mm/min. (ipt)
2	48,000	1,500 (60)	48,000	1,000 (40)
3	38,000	2,100 (83)	38,000	1,500 (60)
4	31,000	2,800 (110)	31,000	2,000 (80)
5	24,000	2,800 (110)	24,000	2,000 (80)
6	20,000	2,800 (110)	20,000	2,000 (80)
8	15,000	2,800 (110)	15,000	2,000 (80)
10	13,000	3,000 (118)	13,000	2,100 (83)
12	10,000	3,000 (118)	10,000	2,100 (83)
16	7,700	3,000 (118)	7,700	2,100 (83)
D.O.C.	Ad	0.1D		0.1D
	Pf	0.2D		0.2D

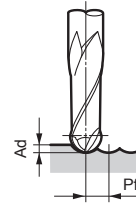

- If cutting noise and vibration occur, please reduce the cutting speed accordingly.
- If the machine cannot reach recommended speed, use the maximum speed that can be achieved.



SUMIBORON ENDMILLS

Mold Finish Master BNP Type

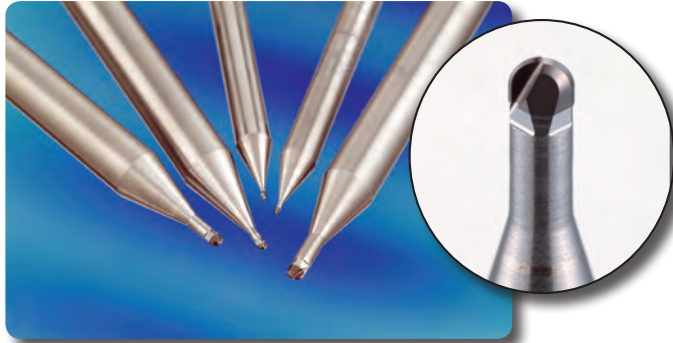

High Speed, High Precision SUMIBORON Mill for Pre-Hardened/Hardened Steel

Features & Benefits

- Longer tool life in high speed, high precision machining of pre-hardened and hardened steel (~HRC70.)
- Uses SUMIBORON BN350 for excellent chipping resistance.
- High precision radial cutting edge profile accuracy of ± 0.0002 in. (0.005mm.)
- Excellent surface finish with a polishing process that is greatly reduced compared to solid carbide endmills.

BNBP Endmill Availability - METRIC

Size	Sumitomo Cat. No.	Stock	Dimensions (mm)						
			BN350	R	øD	L	ød1	ød	ℓ1
ø4 Shank	BNBP2R020-0124	●	0.20	0.4	50	0.37	4.0	0.3	1.2
	BNBP2R030-0154	●	0.30	0.6	50	0.57	4.0	0.4	1.5
	BNBP2R050-0254	●	0.50	1.0	50	0.97	4.0	0.6	2.5
	BNBP2R075-0404	●	0.75	1.5	50	1.47	4.0	0.9	4.0
	BNBP2R100-0554	●	1.00	2.0	50	1.97	4.0	1.4	5.5
ø6 Shank	BNBP2R020-0126	●	0.20	0.4	50	0.37	6.0	0.3	1.2
	BNBP2R030-0156	●	0.30	0.6	50	0.57	6.0	0.4	1.5
	BNBP2R050-0256	●	0.50	1.0	50	0.97	6.0	0.6	2.5
	BNBP2R075-0406	●	0.75	1.5	50	1.47	6.0	0.9	4.0
	BNBP2R100-0556	●	1.00	2.0	50	1.97	6.0	1.4	5.5

BNBP Performance

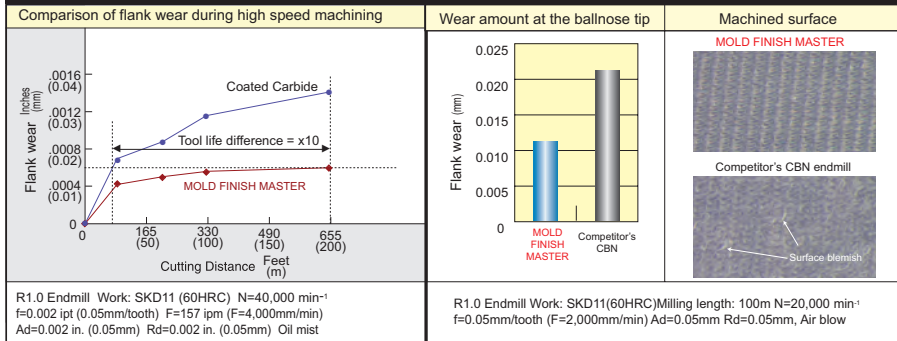

Recommended Running Conditions

Ballnose Radius mm (in)	STAVAX, NAK80, SKD61 (~52HRC)				SDK11 (~62HRC)				SKH (~70HRC)			
	RPM	Feedrate mm/tooth (ipt)	D.O.C.		RPM	Feedrate mm/tooth (ipt)	D.O.C.		RPM	Feedrate mm/tooth (ipt)	D.O.C.	
			Ad mm (in)	Rd mm (in)			Ad mm (in)	Rd mm (in)			Ad mm (in)	Rd mm (in)
R0.2 (.008)	20,000~50,000	.02 (.0008)	.03 (.001)	.03 (.001)	20,000~50,000	.02 (.0008)	.01 (.0004)	.02 (.008)	20,000~50,000	.015 (.0006)	.01 (.0004)	.02 (.0008)
R0.3 (.012)	20,000~50,000	.02 (.0008)	.03 (.001)	.03 (.001)	20,000~50,000	.02 (.0008)	.01 (.0004)	.02 (.0008)	20,000~50,000	.015 (.0006)	.01 (.0004)	.02 (.0008)
R0.5 (.020)	20,000~50,000	.03 (.001)	.05 (.002)	.05 (.002)	20,000~50,000	.03 (.001)	.03 (.001)	.04 (.002)	20,000~50,000	.02 (.0008)	.02 (.0008)	.03 (.001)
R0.75 (.030)	20,000~50,000	.04 (.002)	.08 (.003)	0.1 (.004)	20,000~50,000	.04 (.002)	.05 (.002)	.05 (.002)	20,000~50,000	.03 (.001)	.02 (.0008)	.05 (.002)
R1.0 (.040)	20,000~50,000	.05 (.002)	0.1 (.004)	0.1 (.004)	17,000~50,000	.05 (.002)	.05 (.002)	.05 (.002)	17,000~50,000	.03 (.001)	.03 (.001)	.05 (.002)

- NOTES:
- For stable machining, a more rigid machine is recommended.
 - Air blow or oil mist coolant is recommended.
 - Shorten overhang as much as possible.



NPDB Series SUMIDIA BINDERLESS Ballnose Endmills

NPDB ENDMILLS

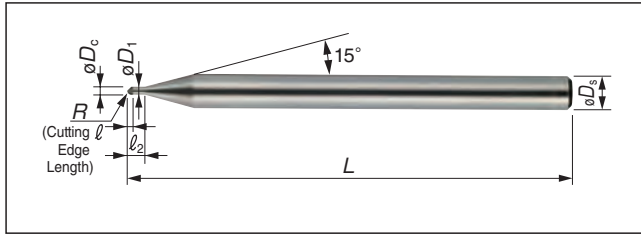

Endmill Identification

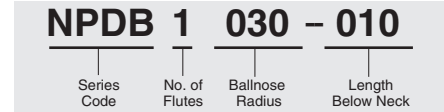

Body

Type	Cat. No.	Stock	Dimensions (mm)						Effective Length by Inclined Angles					
			R	θD_c	L	B	L	θD_1	θD_s	0.5°	1°	1.5°	2°	3°
Precise Finishing	NPDB 1010-004	★	0.1	0.2	0.1	0.4	40	0.18	4	0.44	0.45	0.46	0.47	0.49
	NPDB 1020-008	★	0.2	0.4	0.2	0.8	40	0.38	4	0.83	0.84	0.85	0.86	0.89
	NPDB 1030-010	★	0.3	0.6	0.3	1.0	40	0.58	4	1.05	1.08	1.10	1.13	1.20
	NPDB 1050-020	★	0.5	1.0	0.5	2.0	40	0.95	4	2.08	2.13	2.19	2.24	2.38
	NPDB 1100-030	★	1.0	2.0	1.0	3.0	40	1.95	4	3.13	3.20	3.27	3.35	3.53
Standard Finishing	NPDBS1010-004	★	0.1	0.2	0.1	0.4	40	0.18	4	0.44	0.45	0.46	0.47	0.49
	NPDBS1020-008	★	0.2	0.4	0.2	0.8	40	0.38	4	0.83	0.84	0.85	0.86	0.89
	NPDBS1030-010	★	0.3	0.6	0.3	1.0	40	0.58	4	1.05	1.08	1.10	1.13	1.20
	NPDBS1050-020	★	0.5	1.0	0.5	2.0	40	0.95	4	2.08	2.13	2.19	2.24	2.38
	NPDBS1100-030	★	1.0	2.0	1.0	3.0	40	1.95	4	3.13	3.20	3.27	3.35	3.53

Grade: NPD10



Recommended Cutting Conditions

- Use a machine with high rigidity for stable cutting.
- Non-water soluble coolant recommended. Supply as a mist or external coolant. Take fire prevention precautions to avoid fire hazards caused by sparks igniting during machining or tool breakage.
- Shorten overhang as much as possible.
- Adjust cuttings conditions as necessary as machine rigidity and other conditions may vary.
- Depth of cut shown in the table of conditions are maximum depths. Adjust the actual depth of cut to the desired machined surface finish.

Flat Surface Finishing

Work Material		Carbide			
R (mm)	B (mm)	Spindle Speed (min ⁻¹)	Feed Rate (mm/min)	a_p (mm)	p_r (mm)
0.3	1.0	40,000	200	0.001	0.001
0.5	2.0	40,000	400	0.001	0.003
1.0	3.0	40,000	600	0.001	0.005

Profile Finishing

Work Material		Carbide			
R (mm)	B (mm)	Spindle Speed (min ⁻¹)	Feed Rate (mm/min)	a_p (mm)	p_r (mm)
0.3	1.0	40,000	200	0.003	0.001
0.5	2.0	40,000	400	0.005	0.003
1.0	3.0	40,000	600	0.010	0.005





SUMITOMO

CARBIDE - CBN - DIAMOND

1-800-950-5202

www.sumicarbide.com

DRILL SYSTEMS

Pages 441-526



Solid Carbide Drills

DRILL TECHNICAL DATA

PAGES

Drill Selection Page	442
Solid Carbide Drills	443-471
MDF Flat Bottom Drills.....	472-473
Deep Hole Carbide Drills.....	475-480
MicroDrills & DLC Coated Drills.....	481-487
Replaceable Tip Drills.....	489-499
Indexable Drills.....	501-511
PDL/PCT	512-515
SR Reamer	516-526

DRILL SELECTION

Drill Selection

Drill Identification MDW 1400 P HV

Drill dia. (φ15.0 mm) Series name
Classification code Length code (P)

MDW 01250 GS 2

Drill dia. (φ.125 in) Length code (2,5,8,15,20,25)
Classification code Series name

Application	Type	Series	Coolant		Coating/ Insert Grade	Dia. Min to Max (in / mm)	Drilling Depth	Catalog Number	P		H		M	S	K		N	Page #				
			Internal	External					Soft Steel	General Steel	45HRC	60HRC	Stainless Steel	Titanium Alloy	Inconel	Gray Cast Iron	Ductile Cast Iron		Aluminum Alloy	Copper Alloy		
General Purpose	Solid Carbide - External Coolant	GS	●	DEX Coat	.1110-.6250 2.00-16.00	2XD	MDW□□□□□GS2	✓	✓	●	●	●	●	●	✓	✓	●	●	443 - 453			
					.2010-.6250 2.00-16.00	4XD	MDW□□□□□GS4	●	●	●	●	●	●	●	●	●	●	●	●	●	●	
		HGS	●	DEX Coat	.1094-.6250 1.50-16.00	3XD	MDW□□□□□HGS3	●	●	●	●	●	●	●	●	●	●	●	●	●	454 - 471	
					.1250-.6250 2.00-16.00	5XD	MDW□□□□□HGS5	✓	✓	●	✓	✓	✓	✓	✓	✓	▲	●	●	●	●	
Deep Hole	Spot Facing	MDF - Flat Bottom Drill	●	PVD Coat	.1250-.4725 2.00-12.00	2XD	MDF□□□□S2D	✓	✓	●	●	●	●	●	●	●	●	●	472 - 473			
					XHV - Deep Hole Drill	●	DEX Coat	.1250-.7500 3.00-14.00	12XD	MDW□□□□XHV12	✓	✓	●	●	●	●	●	✓	✓	●	●	475 - 480
Small Diameter	Hole	MDF - Flat Bottom Drill	●	PVD Coat				.1250-.5310 3.00-14.00	20XD	MDW□□□□XHV20	●	●	●	●	●	●	●	●	●	●	482 - 483	
					MLDH - Small Diameter Drill	●	FB Coat	0.03-0.18	10XD	MDUS□□□□-30C	✓	✓	●	●	●	●	●	●	●	●	●	484
MLDH - Small Diameter Drill	●	PVD Coat	0.20-1.00	10XD				MDSS□□□□	✓	✓	✓	●	✓	●	●	✓	✓	●	●	485		
			Non-Ferrous Materials	Replacable Tip Drill	SMD (MTL, MEL, MTL-C)	●	DEX Coat	.4688-1.2125 72.00-30.80	1.5XD	SMDH□□□□S	✓	✓	●	●	●	●	●	●	✓	●	490 - 499	
.4688-1.3189 12.00-33.50	3XD	SMDH□□□□M						✓	✓	●	●	●	●	●	●	✓	●	●	●			
.4688-1.3189 12.00-33.50	5XD	SMDH□□□□L						✓	●	●	✓	●	●	✓	✓	●	●	●	●	●		
.4688-1.2125 13.50-30.80	8XD	SMDH□□□□D						●	●	●	●	●	●	●	●	●	●	✓	✓	●	●	
Indexable	WDX	●	ACP	ACK	.5620-2.625 13.00-68.00	2XD	WDX□□□□D2S1□□	✓	✓	●	●	●	●	●	●	●	●	●	501 - 511			
					WDX	●	ACP	ACK	.5620-2.625 13.00-68.00	3XD	WDX□□□□D3S1□□	●	●	●	●	●	●	●	●	●	●	●
										4XD	WDX□□□□D4S1□□	●	●	●	●	●	●	●	●	●	●	●

✓: Best ●: Good ▲: Requires sharp edge

P Steel **K** Cast Iron **S** Exotic Materials
M Stainless Steel **N** Non-ferrous **H** Hardened Steel





Longer flute lengths for deeper hole capability and more material available for regrinding.

Super Drill for Super Alloys!

Newly developed PVD DEX coating provides improved heat and wear resistance at increased speeds.

DEX coating

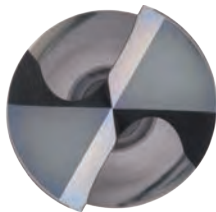

GS Series - External Coolant:

- GS2 (2XD) - Possible to drill to 3XD*
- GS4 (4XD) - Possible to drill to 5XD*

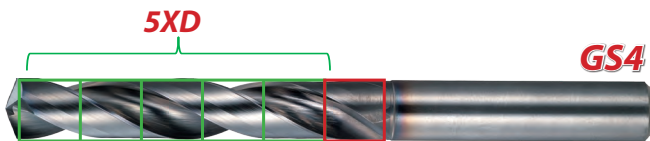

HGS Series - Internal Coolant:

- HGS3 (3XD) - Possible to drill to 4XD*
- HGS5 (5XD) - Possible to drill to 7XD*
- HGS8 (8XD) - Possible to drill to 10XD*

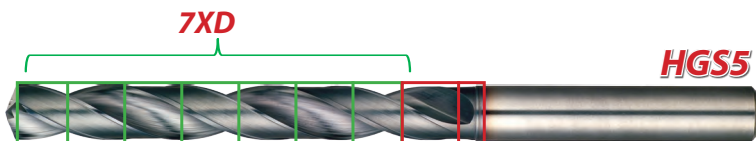

Unique thinning design promotes stable drilling performance.



J-Flute design offers a wide chip pocket, producing more compact chips while achieving higher speeds.



* Not all drills can achieve this depth and some drills may have even deeper capability. *Always check for sufficient flute length.*





■ Features & Benefits

- Long Tool Life**
 New cutting edge design and special DEX coating provide long tool life in a wide variety of work materials
- Stable Chip Evacuation**
 New flute design and wide chip pocket allows for excellent chip management and evacuation
- Quiet Cutting & Stable Cutting**
 Stable drilling with minimal vibration even in small machine applications
- Environmentally Friendly**
 Compatible with MQL (Minimum Quantity Lubrication) Systems

■ Performance

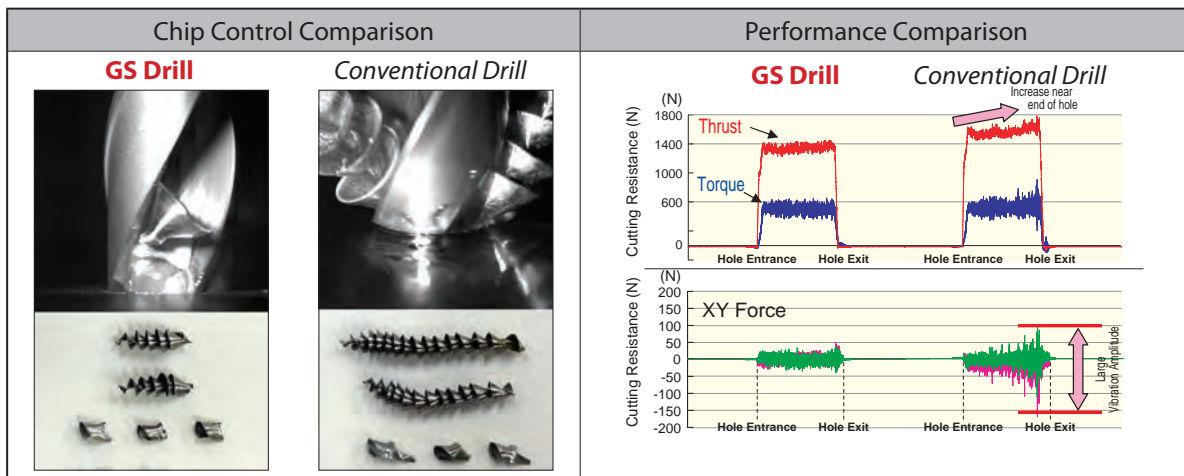

The GS Drill provides better stability throughout the drilling process.

Tool: MDW0800GS4
 Work Material: 1049 steel (200HB)
 Cutting Conditions: $V_c = 80\text{m/min}$ (262 sfm)
 $f = 0.25\text{mm/rev}$ (0.10 ipr)
 $H = 24\text{mm}$ (0.945 in)
 External coolant (water soluble)

■ Application Examples

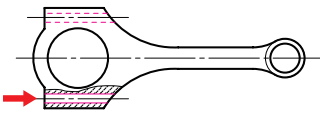
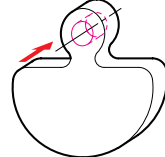
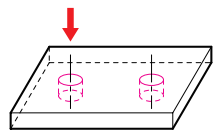
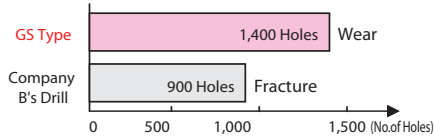
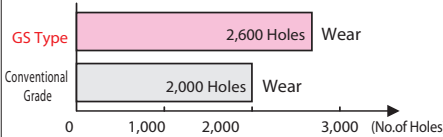
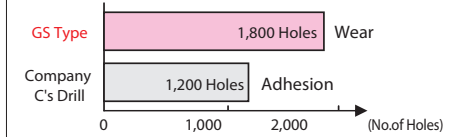
S43C (250HB) Automotive Component	Boron Steel (30HRC) Machine Component	SS400 Machine Component
		
Tool: MDW0970GS4 Cutting Conditions: 262 SFM $f=0.0098$ IPR $H=1$ in. External Coolant (Water Soluble)	Tool: MDW0980GS2 Cutting Conditions: $v_c=230$ SFM $f=0.0059$ IPR $H=.276$ in. External Coolant (Water Soluble)	Tool: MDW1050GS4 Cutting Conditions: $v_c=500$ SFM $f=0.012$ IPR $H=.012$ in. External Coolant (Water Soluble)
Achieving 1.5x tool life! Reduced wear on peripheral cutting edge	1.3x tool life of conventional tools! Good circularity and cylindricity.	Achieving 1.5x tool life! Good chip control
		



MDW-GS2 Series Solid Carbide Drills

SERIES

MDW-GS2

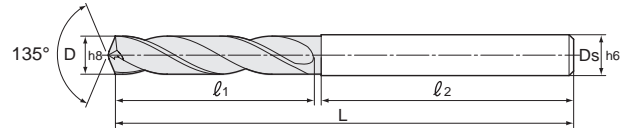

MDW-GS2 2XD drill for excellent chip management and long tool life (External coolant)

Catalog Number (inch/metric)	Stock	Fractional Wire & Letters	Diameter D (in)	Diameter D (mm)	Overall Length L (in/mm)	Flute Length l_1 (in/mm)	Shank Length l_2 (in/mm)	Shank Diameter D_s (in/mm)	Tap Size
MDW0200GS2	●		0.0787	2.00	45.0	8.0	34.0	3.0	
MDW0210GS2	●		0.0827	2.10	45.0	10.0	32.0	3.0	3-56
MDW0220GS2	●		0.0866	2.20	45.0	10.0	32.0	3.0	
MDW0230GS2	●		0.0906	2.30	45.0	10.0	32.0	3.0	
MDW00937GS2	●	3/32	0.0940	2.38	1.772	0.394	1.260	0.1250	
MDW0240GS2	●		0.0945	2.40	45.0	10.0	32.0	3.0	
MDW0250GS2	●		0.0984	2.50	45.0	10.0	32.0	3.0	
MDW0260GS2	●		0.1024	2.60	45.0	13.0	30.0	3.0	
MDW0270GS2	●		0.1063	2.70	45.0	13.0	30.0	3.0	6-32
MDW0280GS2	●		0.1102	2.80	45.0	13.0	30.0	3.0	
MDW01110GS2	●		0.1110	2.82	1.7717	0.5118	1.1811	0.1250	
MDW01130GS2	●		0.1130	2.87	1.7717	0.5118	1.1811	0.1250	6-40
MDW0290GS2	●		0.1142	2.90	45.0	13.0	30.0	3.0	3.5x.6
MDW01160GS2	●		0.1160	2.95	1.7717	0.5118	1.1811	0.1250	
MDW0300GS2	●		0.1181	3.00	45.0	13.0	30.0	3.0	
MDW01200GS2	●		0.1200	3.05	1.7717	0.5118	1.1811	0.1250	
MDW0310GS2	●		0.1220	3.10	54.0	19.0	33.0	4.0	
MDW01250GS2	●	1/8	0.1250	3.18	1.7717	0.5118	1.1811	0.1250	
MDW0320GS2	●		0.1260	3.20	54.0	19.0	33.0	4.0	
MDW01285GS2	●		0.1285	3.26	2.1260	0.7480	1.2992	0.1562	
MDW0330GS2	●		0.1299	3.30	54.0	19.0	33.0	4.0	M4x.7
MDW0340GS2	●		0.1339	3.40	54.0	19.0	33.0	4.0	
MDW01360GS2	●		0.1360	3.45	2.1260	0.7480	1.2992	0.1562	8-32/8-36
MDW0350GS2	●		0.1378	3.50	54.0	19.0	33.0	4.0	
MDW01405GS2	●		0.1405	3.57	2.1260	0.8268	1.2992	0.1562	
MDW01406GS2	●		0.1406	3.57	2.1260	0.8268	1.2992	0.1562	
MDW0360GS2	●		0.1417	3.60	54.0	21.0	33.0	4.0	
MDW01440GS2	●		0.1440	3.66	2.1260	0.8268	1.2992	0.1562	
MDW0370GS2	●		0.1457	3.70	54.0	21.0	33.0	4.0	M4.5x.7
MDW01470GS2	●		0.1470	3.73	2.1260	0.8268	1.2992	0.1562	
MDW01495GS2	●		0.1495	3.797	2.1260	0.8268	1.2992	0.1562	10-24
MDW0380GS2	●		0.1496	3.80	54.0	21.0	33.0	4.0	
MDW01520GS2	●		0.1520	3.86	2.1260	0.8268	1.2992	0.1562	
MDW0390GS2	●		0.1535	3.90	54.0	21.0	33.0	4.0	
MDW01540GS2	●		0.1540	3.91	2.1260	0.8268	1.2992	0.1562	
MDW01562GS2	●	5/32	0.1562	3.97	2.1260	0.8268	1.2992	0.1562	
MDW01570GS2	●		0.1570	3.99	2.4016	0.9055	1.4173	0.1875	
MDW0400GS2	●		0.1575	4.00	54.0	21.0	33.0	4.0	
MDW01590GS2	●	#21	0.1590	4.04	2.4016	0.9055	1.4173	0.1875	10-32
MDW01610GS2	●		0.1610	4.09	2.4016	0.9055	1.4173	0.1875	
MDW0410GS2	●		0.1614	4.10	61.0	23.0	36.0	5.0	
MDW0420GS2	●		0.1654	4.20	61.0	23.0	36.0	5.0	M5x.8
MDW01660GS2	●		0.1660	4.22	2.4016	0.9055	1.4173	0.1875	
MDW0430GS2	●		0.1693	4.30	61.0	23.0	36.0	5.0	
MDW01695GS2	●		0.1695	4.31	2.4016	0.9055	1.4173	0.1875	
MDW01719GS2	●	11/64	0.1719	4.37	2.4016	0.9055	1.4173	0.1875	
MDW01730GS2	●		0.1730	4.39	2.4016	0.9055	1.4173	0.1875	
MDW0440GS2	●		0.1732	4.40	61.0	23.0	36.0	5.0	
MDW01770GS2	●		0.1770	4.49	2.4016	0.9055	1.4173	0.1875	12-24
MDW0450GS2	●		0.1772	4.50	61.0	23.0	36.0	5.0	
MDW01800GS2	●		0.1800	4.57	2.4016	0.9843	1.4173	0.1875	
MDW0460GS2	●		0.1811	4.60	61.0	25.0	36.0	5.0	
MDW01820GS2	●		0.1820	4.62	2.4016	0.9843	1.4173	0.1875	12-28
MDW01850GS2	●		0.1850	4.70	2.4016	0.9843	1.4173	0.1875	
MDW0470GS2	●		0.1850	4.70	61.0	25.0	36.0	5.0	

●=USA stocked item

Some drills can achieve greater depths. Always check for sufficient flute length. Note: Special diameters available upon request.



SERIES MDW-GS2

MDW-GS2 Series Solid Carbide Drills

(continued from previous page)

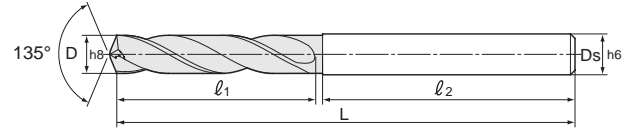
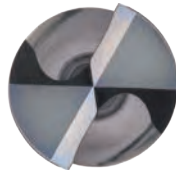

MDW-GS2 2XD drill for excellent chip management and long tool life (External coolant)

Catalog Number (inch/metric)	Stock	Fractional Wire & Letters	Diameter D (in)	Diameter D (mm)	Overall Length L (in/mm)	Flute Length l_1 (in/mm)	Shank Length l_2 (in/mm)	Shank Diameter D_s (in/mm)	Tap Size
MDW01875GS2	●	3/16	0.1875	4.76	2.4016	0.9843	1.4173	0.1875	
MDW0480GS2	●		0.1890	4.80	61.0	25.0	36.0	5.0	
MDW01890GS2	●		0.1890	4.80	2.5591	0.9843	1.4961	0.2344	
MDW01910GS2	●		0.1910	4.85	2.5591	0.9843	1.4961	0.2344	
MDW0490GS2	●		0.1929	4.90	61.0	25.0	36.0	5.0	
MDW01935GS2	●		0.1935	4.91	2.5591	0.9843	1.4961	0.2344	
MDW01960GS2	●		0.1960	4.98	2.5591	0.9843	1.4961	0.2344	
MDW0500GS2	●		0.1969	5.00	61.0	25.0	36.0	5.0	
MDW0510GS2	●		0.2008	5.10	65.0	25.0	38.0	6.0	M6x1
MDW02010GS2	●	#7	0.2010	5.11	2.5591	0.9843	1.4961	0.2344	1/4-20
MDW02031GS2	●	13/64	0.2031	5.16	2.5591	0.9843	1.4961	0.2344	
MDW02040GS2	●		0.2040	5.18	2.5591	0.9843	1.4961	0.2344	
MDW0520GS2	●		0.2047	5.20	65.0	25.0	38.0	6.0	
MDW02055GS2	●		0.2055	5.22	2.5591	0.9843	1.4961	0.2344	
MDW0530GS2	●		0.2087	5.30	65.0	25.0	38.0	6.0	
MDW02090GS2	●		0.2090	5.31	2.5591	0.9843	1.4961	0.2344	
MDW0540GS2	●		0.2126	5.40	65.0	25.0	38.0	6.0	
MDW02130GS2	●	#3	0.2130	5.41	2.5591	0.9843	1.4961	0.2344	
MDW0550GS2	●		0.2165	5.50	65.0	25.0	38.0	6.0	
MDW02188GS2	●	7/32	0.2188	5.56	2.5591	1.0630	1.4961	0.2344	1/4-28
MDW0560GS2	●		0.2205	5.60	65.0	27.0	38.0	6.0	
MDW02210GS2	●	#2	0.2210	5.61	2.5591	1.0630	1.4961	0.2344	
MDW0570GS2	●		0.2244	5.70	65.0	27.0	38.0	6.0	
MDW02280GS2	●		0.2280	5.79	2.5591	1.0630	1.4961	0.2344	
MDW0580GS2	●		0.2283	5.80	65.0	27.0	38.0	6.0	
MDW0590GS2	●		0.2323	5.90	65.0	27.0	38.0	6.0	
MDW02340GS2	●		0.2340	5.94	2.5591	1.0630	1.4961	0.2344	
MDW02344GS2	●	15/64	0.2344	5.95	2.5591	1.0630	1.4961	0.2344	
MDW0600GS2	●		0.2362	6.00	65.0	27.0	38.0	6.0	M7x1
MDW02380GS2	●		0.2380	6.05	2.8740	1.2205	1.5748	0.2812	
MDW0610GS2	●		0.2402	6.10	73.0	31.0	40.0	7.0	
MDW02420GS2	●	#C	0.2420	6.15	2.8740	1.2205	1.5748	0.2812	
MDW0620GS2	●		0.2441	6.20	73.0	31.0	40.0	7.0	
MDW02460GS2	●		0.2460	6.25	2.8740	1.2205	1.5748	0.2812	
MDW0630GS2	●		0.2480	6.30	73.0	31.0	40.0	7.0	
MDW02500GS2	●	1/4	0.2500	6.35	2.8740	1.2205	1.5748	0.2812	
MDW0640GS2	●		0.2520	6.40	73.0	31.0	40.0	7.0	
MDW0650GS2	●		0.2559	6.50	73.0	31.0	40.0	7.0	
MDW02570GS2	●	#F	0.2570	6.53	2.8740	1.2992	1.5748	0.2812	5/16-18
MDW0660GS2	●		0.2598	6.60	73.0	33.0	40.0	7.0	
MDW02600GS2	●		0.2600	6.604	2.8740	1.2992	1.5748	0.2812	
MDW02610GS2	●		0.2610	6.63	2.8740	1.2992	1.5748	0.2812	
MDW0670GS2	●		0.2638	6.70	73.0	33.0	40.0	7.0	
MDW02656GS2	●	17/64	0.2656	6.75	2.8740	1.2992	1.5748	0.2812	
MDW02660GS2	●	#H	0.2660	6.76	2.8740	1.2992	1.5748	0.2812	
MDW02677GS2	●		0.2677	6.80	2.8740	1.2992	1.5748	0.2812	
MDW0680GS2	●		0.2677	6.80	73.0	33.0	40.0	7.0	
MDW0690GS2	●		0.2717	6.90	73.0	33.0	40.0	7.0	
MDW02720GS2	●	#I	0.2720	6.91	2.8740	1.2992	1.5748	0.2812	5/16-24
MDW0700GS2	●		0.2756	7.00	73.0	33.0	40.0	7.0	
MDW02756GS2	●		0.2756	7.00	2.8740	1.2992	1.5748	0.2812	
MDW02770GS2	●	#J	0.2770	7.04	2.8740	1.2992	1.5748	0.2812	
MDW0710GS2	●		0.2795	7.10	78.0	33.0	43.0	8.0	
MDW02810GS2	●		0.2810	7.14	2.8740	1.2992	1.5748	0.2812	

● = USA stocked item ★ = Worldwide Warehouse item available in 10 business days

Some drills can achieve greater depths. Always check for sufficient flute length. Note: Special diameters available upon request.



MDW-GS2 Series Solid Carbide Drills

SERIES MDW-GS2

(continued from previous page)

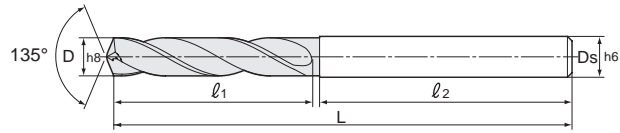
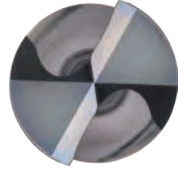

MDW-GS2 2XD drill for excellent chip management and long tool life (External coolant)

Catalog Number (inch/metric)	Stock	Fractional Wire & Letters	Diameter D (in)	Diameter D (mm)	Overall Length L (in/mm)	Flute Length l_1 (in/mm)	Shank Length l_2 (in/mm)	Shank Diameter D_s (in/mm)	Tap Size
MDW0281GS2	●	9/32	0.2812	7.142	2.8740	1.2992	1.5748	0.2812	
MDW0720GS2	●		0.2835	7.20	78.0	33.0	43.0	8.0	
MDW0730GS2	●		0.2874	7.30	78.0	33.0	43.0	8.0	
MDW02900GS2	●		0.2900	7.37	3.0709	1.2992	1.6929	0.3125	
MDW0740GS2	●		0.2913	7.40	78.0	33.0	43.0	8.0	
MDW02950GS2	●		0.2950	7.49	3.0709	1.2992	1.6929	0.3125	
MDW0750GS2	●		0.2953	7.50	78.0	33.0	43.0	8.0	
MDW02969GS2	●	19/64	0.2969	7.54	3.0709	1.4173	1.6535	0.3125	
MDW0760GS2	●		0.2992	7.60	78.0	36.0	42.0	8.0	
MDW03020GS2	●		0.3020	7.67	3.0709	1.4173	1.6535	0.3125	
MDW0770GS2	●		0.3031	7.70	78.0	36.0	42.0	8.0	
MDW0780GS2	●		0.3071	7.80	78.0	36.0	42.0	8.0	M9x1.25
MDW0790GS2	●		0.3110	7.90	78.0	36.0	42.0	8.0	
MDW03125GS2	●	5/16	0.3125	7.94	3.0709	1.4173	1.6535	0.3125	3/8-16
MDW0800GS2	●		0.3150	8.00	78.0	36.0	42.0	8.0	
MDW03160GS2	●		0.3160	8.03	3.2283	1.4173	1.7323	0.3594	
MDW0810GS2	●		0.3189	8.10	82.0	36.0	44.0	9.0	
MDW0820GS2	●		0.3228	8.20	82.0	36.0	44.0	9.0	
MDW03230GS2	●	#P	0.3230	8.204	3.2283	1.4173	1.7323	0.3594	
MDW0830GS2	●		0.3268	8.30	82.0	36.0	44.0	9.0	
MDW03281GS2	●	21/64	0.3281	8.33	3.2283	1.4173	1.7323	0.3594	
MDW03307GS2	●		0.3307	8.40	3.2283	1.4173	1.7323	0.3594	
MDW0840GS2	●		0.3307	8.40	82.0	36.0	44.0	9.0	
MDW03320GS2	●	#Q	0.3320	8.43	3.2283	1.4173	1.7323	0.3594	
MDW0850GS2	●		0.3346	8.50	82.0	36.0	44.0	9.0	M10x1.5
MDW0860GS2	●		0.3386	8.60	82.0	38.0	44.0	9.0	
MDW03386GS2	●		0.3386	8.60	3.2283	1.4961	1.7323	0.3594	
MDW03390GS2	●		0.3390	8.61	3.2283	1.4961	1.7323	0.3594	3/8-24
MDW0870GS2	●		0.3425	8.70	82.0	38.0	44.0	9.0	
MDW03438GS2	●	11/32	0.3438	8.73	3.2283	1.4961	1.7323	0.3594	
MDW0880GS2	●		0.3465	8.80	82.0	38.0	44.0	9.0	
MDW03475GS2	●		0.3475	8.83	3.2283	1.4961	1.7323	0.3594	
MDW03480GS2	●		0.3480	8.84	3.2283	1.4961	1.7323	0.3594	
MDW0890GS2	●		0.3504	8.90	82.0	38.0	44.0	9.0	
MDW0900GS2	●		0.3543	9.00	82.0	38.0	44.0	9.0	
MDW03580GS2	●		0.3580	9.09	3.2283	1.4961	1.7323	0.3594	
MDW0910GS2	●		0.3583	9.10	87.0	38.0	47.0	10.0	
MDW03594GS2	●	23/64	0.3594	9.13	3.2283	1.4961	1.7323	0.3594	
MDW0920GS2	●		0.3622	9.20	87.0	38.0	47.0	10.0	
MDW0930GS2	●		0.3661	9.30	87.0	38.0	47.0	10.0	
MDW03680GS2	●	#U	0.3680	9.35	3.4252	1.4961	1.8504	0.3906	7/16-14
MDW0940GS2	●		0.3701	9.40	87.0	38.0	47.0	10.0	
MDW0950GS2	●		0.3740	9.50	87.0	38.0	47.0	10.0	
MDW03750GS2	●	3/8	0.3750	9.53	3.4252	1.6142	1.8110	0.3906	
MDW03770GS2	●		0.3770	9.58	3.4252	1.6142	1.8110	0.3906	
MDW0960GS2	●		0.3780	9.60	87.0	41.0	46.0	10.0	
MDW03780GS2	●		0.3780	9.60	3.4252	1.6142	1.8110	0.3906	
MDW0970GS2	●		0.3819	9.70	87.0	41.0	46.0	10.0	
MDW0980GS2	●		0.3858	9.80	87.0	41.0	46.0	10.0	
MDW03860GS2	●		0.3860	9.804	3.4252	1.6142	1.8110	0.3906	
MDW0990GS2	●		0.3898	9.90	87.0	41.0	46.0	10.0	
MDW03906GS2	●	25/64	0.3906	9.92	3.4252	1.6142	1.8110	0.3906	7/16-20
MDW1000GS2	●		0.3937	10.00	87.0	41.0	46.0	10.0	
MDW03970GS2	●		0.3970	10.08	3.6614	1.6142	1.9685	0.4375	

●=USA stocked item

Some drills can achieve greater depths. Always check for sufficient flute length. Note: Special diameters available upon request.



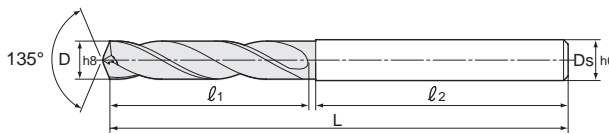
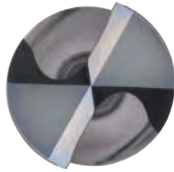

(continued from previous page)

MDW-GS2 2XD drill for excellent chip management and long tool life (External coolant)

Catalog Number (inch/metric)	Stock	Fractional Wire & Letters	Diameter D (in)	Diameter D (mm)	Overall Length L (in/mm)	Flute Length l_1 (in/mm)	Shank Length l_2 (in/mm)	Shank Diameter D_s (in/mm)	Tap Size
MDW1010GS2	●		0.3976	10.10	93.0	41.0	50.0	11.0	
MDW1020GS2	●		0.4016	10.20	93.0	41.0	50.0	11.0	M12x1.75
MDW04040GS2	●		0.4040	10.26	3.6614	1.6142	1.9685	0.4375	
MDW1030GS2	●		0.4055	10.30	93.0	41.0	50.0	11.0	
MDW04062GS2	●	13/32	0.4062	10.32	3.6614	1.6142	1.9685	0.4375	
MDW1040GS2	●		0.4094	10.40	93.0	41.0	50.0	11.0	
MDW04130GS2	●		0.4130	10.49	3.6614	1.6142	1.9685	0.4375	
MDW1050GS2	●		0.4134	10.50	93.0	41.0	50.0	11.0	
MDW1060GS2	●		0.4173	10.60	93.0	45.0	48.0	11.0	
MDW1070GS2	●		0.4213	10.70	93.0	45.0	48.0	11.0	
MDW04219GS2	●	27/64	0.4219	10.72	3.6614	1.7717	1.8898	0.4375	1/2-13
MDW1080GS2	●		0.4252	10.80	93.0	45.0	48.0	11.0	
MDW1090GS2	●		0.4291	10.90	93.0	45.0	48.0	11.0	
MDW1100GS2	●		0.4331	11.00	93.0	45.0	48.0	11.0	
MDW1110GS2	●		0.4370	11.10	100.0	45.0	53.0	12.0	
MDW04375GS2	●	7/16	0.4375	11.11	3.6614	1.7717	1.8898	0.4375	
MDW1120GS2	●		0.4409	11.20	100.0	45.0	53.0	12.0	
MDW1130GS2	●		0.4449	11.30	100.0	45.0	53.0	12.0	
MDW1140GS2	●		0.4488	11.40	100.0	45.0	53.0	12.0	
MDW1150GS2	●		0.4528	11.50	100.0	45.0	53.0	12.0	
MDW04531GS2	●	29/64	0.4531	11.51	3.9370	1.8504	2.0866	0.4688	1/2-20
MDW1160GS2	●		0.4567	11.60	100.0	47.0	53.0	12.0	
MDW04570GS2	●		0.4570	11.61	3.9370	1.8504	2.0866	0.4688	
MDW1170GS2	●		0.4606	11.70	100.0	47.0	53.0	12.0	
MDW1180GS2	●		0.4646	11.80	100.0	47.0	53.0	12.0	
MDW1190GS2	●		0.4685	11.90	100.0	47.0	53.0	12.0	
MDW04688GS2	●	15/32	0.4688	11.91	3.9370	1.8504	2.0866	0.4688	
MDW1200GS2	●		0.4724	12.00	100.0	47.0	53.0	12.0	M14x2
MDW1210GS2	●		0.4764	12.10	100.0	47.0	51.0	13.0	
MDW1220GS2	●		0.4803	12.20	100.0	47.0	51.0	13.0	
MDW1230GS2	●		0.4843	12.30	100.0	47.0	51.0	13.0	9/16-12
MDW04844GS2	●	31/64	0.4844	12.304	3.9370	1.8504	2.0079	0.5156	
MDW1240GS2	●		0.4882	12.40	100.0	47.0	51.0	13.0	
MDW1250GS2	●		0.4921	12.50	100.0	47.0	51.0	13.0	
MDW1260GS2	●		0.4961	12.60	100.0	49.0	51.0	13.0	
MDW1270GS2	●	1/2	0.5000	12.70	100.0	49.0	51.0	13.0	
MDW05000GS2	●	1/2	0.5000	12.70	3.9370	1.9291	2.0079	0.5156	
MDW1280GS2	●		0.5039	12.80	100.0	49.0	51.0	13.0	
MDW05050GS2	●		0.5050	12.83	3.9370	1.9291	2.0079	0.5156	
MDW1290GS2	●		0.5079	12.90	100.0	49.0	51.0	13.0	
MDW1300GS2	●		0.5118	13.00	100.0	49.0	51.0	13.0	
MDW05156GS2	●	33/64	0.5156	13.09	3.9370	1.9291	2.0079	0.5156	9/16-18
MDW1310GS2	●		0.5157	13.10	105.0	50.0	53.0	14.0	
MDW1320GS2	●		0.5197	13.20	105.0	50.0	53.0	14.0	
MDW1330GS2	●		0.5236	13.30	105.0	50.0	53.0	14.0	
MDW1340GS2	●		0.5276	13.40	105.0	50.0	53.0	14.0	
MDW05312GS2	●	17/32	0.5312	13.49	4.1339	1.9685	2.0866	0.5469	5/8-11
MDW1350GS2	●		0.5315	13.50	105.0	50.0	53.0	14.0	
MDW1360GS2	●		0.5354	13.60	105.0	52.0	53.0	14.0	
MDW1370GS2	●		0.5394	13.70	105.0	52.0	53.0	14.0	
MDW1380GS2	●		0.5433	13.80	105.0	52.0	53.0	14.0	
MDW05469GS2	●	35/64	0.5469	13.89	4.1339	2.0472	2.0866	0.5469	M16x2
MDW1390GS2	●		0.5472	13.90	105.0	52.0	53.0	14.0	
MDW1400GS2	●		0.5512	14.00	105.0	52.0	53.0	14.0	

● = USA stocked item

Some drills can achieve greater depths. Always check for sufficient flute length. Note: Special diameters available upon request.

(continued on next page)



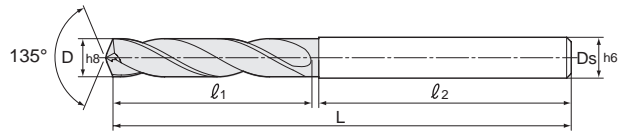
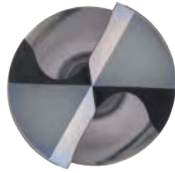

(continued from previous page)

MDW-GS2 2XD drill for excellent chip management and long tool life (External coolant)

Catalog Number (inch/metric)	Stock	Fractional Wire & Letters	Diameter D (in)	Diameter D (mm)	Overall Length L (in/mm)	Flute Length l_1 (in/mm)	Shank Length l_2 (in/mm)	Shank Diameter D_s (in/mm)	Tap Size
MDW1410GS2	●		0.5551	14.10	108.0	52.0	55.0	15.0	
MDW1420GS2	●		0.5591	14.20	108.0	52.0	55.0	15.0	
MDW05625GS2	●	9/16	0.5625	14.29	4.2520	2.0472	2.1654	0.5937	
MDW1430GS2	●		0.5630	14.30	108.0	52.0	55.0	15.0	
MDW1440GS2	●		0.5669	14.40	108.0	52.0	55.0	15.0	
MDW1450GS2	●		0.5709	14.50	108.0	52.0	55.0	15.0	
MDW1460GS2	●		0.5748	14.60	108.0	53.0	55.0	15.0	
MDW05781GS2	●	37/64	0.5781	14.68	4.2520	2.0866	2.1654	0.5937	5/8-18
MDW1470GS2	●		0.5787	14.70	108.0	53.0	55.0	15.0	
MDW1480GS2	●		0.5827	14.80	108.0	53.0	55.0	15.0	
MDW1490GS2	●		0.5866	14.90	108.0	53.0	55.0	15.0	
MDW1500GS2	●		0.5906	15.00	108.0	53.0	55.0	15.0	
MDW05937GS2	●	19/32	0.5937	15.08	4.2520	2.0866	2.1654	0.5937	
MDW1510GS2	●		0.5945	15.10	112.0	53.0	57.0	16.0	
MDW1520GS2	●		0.5984	15.20	112.0	53.0	57.0	16.0	
MDW1530GS2	●		0.6024	15.30	112.0	53.0	57.0	16.0	
MDW1540GS2	●		0.6063	15.40	112.0	53.0	57.0	16.0	
MDW06094GS2	●	39/64	0.6094	15.48	4.4094	2.0866	2.2441	0.6250	11/16-12
MDW1550GS2	●		0.6102	15.50	112.0	53.0	57.0	16.0	M18x2.5
MDW1560GS2	●		0.6142	15.60	112.0	55.0	57.0	16.0	
MDW1570GS2	●		0.6181	15.70	112.0	55.0	57.0	16.0	
MDW1580GS2	●		0.6220	15.80	112.0	55.0	57.0	16.0	
MDW06250GS2	●	5/8	0.6250	15.88	4.4094	2.1654	2.2441	0.6250	11/16-16
MDW1590GS2	●		0.6260	15.90	112.0	55.0	57.0	16.0	
MDW1600GS2	●		0.6299	16.00	112.0	55.0	57.0	16.0	
MDW06406GS2	●	41/64	0.6406	16.27	4.567	2.205	2.323	0.669	
MDW1650GS2	★		0.6496	16.50	116	56	59	17	
MDW06562GS2	●	21/32	0.6562	16.67	4.567	2.244	2.323	0.669	3/4-10
MDW1700GS2	★		0.6693	17.00	116	57	59	17	
MDW06875GS2	●	11/16	0.6875	17.46	4.724	2.283	2.402	0.709	3/4-16
MDW1750GS2	★		0.6890	17.50	120	58	61	18	
MDW07031GS2	●	45/64	0.7031	17.86	4.724	2.323	2.402	0.709	
MDW1800GS2	★		0.7087	18.00	120	59	61	18	
MDW07187GS2	●	23/32	0.7187	18.25	4.843	2.323	2.480	0.748	
MDW1850GS2	★		0.7283	18.50	123	59	63	19	
MDW07344GS2	●	47/64	0.7344	18.65	4.843	2.362	2.480	0.748	7/8-9
MDW1900GS2	★		0.7480	19.00	123	60	63	19	
MDW07500GS2	●	3/4	0.7500	19.05	5.000	2.402	2.559	0.787	
MDW1950GS2	★		0.7677	19.50	127	61	65	20	
MDW07812GS2	●	25/32	0.7812	19.84	5.000	2.441	2.559	0.787	
MDW2000GS2	★		0.7874	20.00	127	62	65	20	

●=USA stocked item

Some drills can achieve greater depths. Always check for sufficient flute length. Note: Special diameters available upon request.

★ = Product expansion



SERIES
MDW-GS4

MDW-GS4 Series Solid Carbide Drills

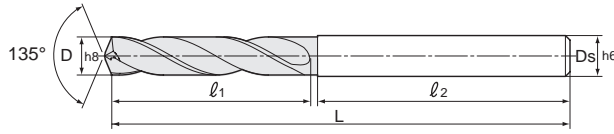
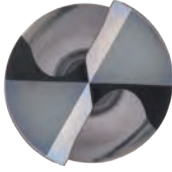

MDW-GS4 4XD drill for excellent chip management and long tool life (External coolant)

Catalog Number (inch/metric)	Stock	Fractional Wire & Letters	Diameter D (in)	Diameter D (mm)	Overall Length L (in/mm)	Flute Length l_1 (in/mm)	Shank Length l_2 (in/mm)	Shank Diameter D_s (in/mm)	Tap Size
MDW0200GS4	●		0.0787	2.00	49.0	15.0	31.0	3.0	
MDW0210GS4	●		0.0827	2.10	49.0	17.0	30.0	3.0	3-56
MDW0220GS4	●		0.0866	2.20	49.0	17.0	30.0	3.0	
MDW0230GS4	●		0.0906	2.30	49.0	17.0	30.0	3.0	
MDW00937GS4	●	3/32	0.0937	2.38	1.9291	0.6693	1.1811	0.125	
MDW0240GS4	●		0.0945	2.40	49.0	17.0	30.0	3.0	
MDW0250GS4	●		0.0984	2.50	49.0	17.0	30.0	3.0	
MDW0260GS4	●		0.1024	2.60	49.0	19.0	30.0	3.0	
MDW0270GS4	●		0.1063	2.70	49.0	19.0	30.0	3.0	6-32
MDW0280GS4	●		0.1102	2.80	49.0	19.0	30.0	3.0	
MDW0290GS4	●		0.1142	2.90	49.0	19.0	30.0	3.0	3.5x.6
MDW0300GS4	●		0.1181	3.00	49.0	19.0	30.0	3.0	
MDW0310GS4	●		0.1220	3.10	60.0	24.0	34.0	4.0	
MDW0320GS4	●		0.1260	3.20	60.0	24.0	34.0	4.0	
MDW0330GS4	●		0.1299	3.30	60.0	24.0	34.0	4.0	M4x.7
MDW0340GS4	●		0.1339	3.40	60.0	24.0	34.0	4.0	
MDW0350GS4	●		0.1378	3.50	60.0	24.0	34.0	4.0	
MDW0360GS4	●		0.1417	3.60	60.0	27.0	33.0	4.0	
MDW0370GS4	●		0.1457	3.70	60.0	27.0	33.0	4.0	M4.5x.7
MDW0380GS4	●		0.1496	3.80	60.0	27.0	33.0	4.0	
MDW0390GS4	●		0.1535	3.90	60.0	27.0	33.0	4.0	
MDW0400GS4	●		0.1575	4.00	60.0	27.0	33.0	4.0	
MDW0410GS4	●		0.1614	4.10	76.0	31.0	43.0	5.0	
MDW0420GS4	●		0.1654	4.20	76.0	31.0	43.0	5.0	M5x.8
MDW0430GS4	●		0.1693	4.30	76.0	31.0	43.0	5.0	
MDW0440GS4	●		0.1732	4.40	76.0	31.0	43.0	5.0	
MDW0450GS4	●		0.1772	4.50	76.0	31.0	43.0	5.0	
MDW0460GS4	●		0.1811	4.60	76.0	38.0	38.0	5.0	
MDW0470GS4	●		0.1850	4.70	76.0	38.0	38.0	5.0	
MDW0480GS4	●		0.1890	4.80	76.0	38.0	38.0	5.0	
MDW0490GS4	●		0.1929	4.90	76.0	38.0	38.0	5.0	
MDW0500GS4	●		0.1969	5.00	76.0	38.0	38.0	5.0	
MDW0510GS4	●		0.2008	5.10	81.0	39.0	40.0	6.0	M6x1
MDW02010GS4	●	#7	0.2010	5.11	3.1890	1.5354	1.5748	0.2344	1/4-20
MDW0520GS4	●		0.2047	5.20	81.0	39.0	40.0	6.0	
MDW0530GS4	●		0.2087	5.30	81.0	39.0	40.0	6.0	
MDW0540GS4	●		0.2126	5.40	81.0	39.0	40.0	6.0	
MDW0550GS4	●		0.2165	5.50	81.0	39.0	40.0	6.0	
MDW0560GS4	●		0.2205	5.60	81.0	41.0	40.0	6.0	
MDW0570GS4	●		0.2244	5.70	81.0	41.0	40.0	6.0	
MDW0580GS4	●		0.2283	5.80	81.0	41.0	40.0	6.0	
MDW0590GS4	●		0.2323	5.90	81.0	41.0	40.0	6.0	
MDW0600GS4	●		0.2362	6.00	81.0	41.0	40.0	6.0	
MDW0610GS4	●		0.2402	6.10	83.0	42.0	40.0	7.0	M7x1
MDW0620GS4	●		0.2441	6.20	83.0	42.0	40.0	7.0	
MDW02460GS4	●		0.2460	6.25	3.2677	1.6535	1.5748	0.2812	
MDW0630GS4	●		0.2480	6.30	83.0	42.0	40.0	7.0	
MDW02500GS4	●	1/4	0.2500	6.35	3.2677	1.6535	1.5748	0.2812	
MDW0640GS4	●		0.2520	6.40	83.0	42.0	40.0	7.0	
MDW0650GS4	●		0.2559	6.50	83.0	42.0	40.0	7.0	
MDW02570GS4	●	#F	0.2570	6.53	3.2677	1.6929	1.5748	0.2812	5/16-18
MDW0660GS4	●		0.2598	6.60	83.0	43.0	40.0	7.0	
MDW02610GS4	●		0.2610	6.63	3.2677	1.6929	1.5748	0.2812	
MDW0670GS4	●		0.2638	6.70	83.0	43.0	40.0	7.0	

●=USA stocked item

Some drills can achieve greater depths. Always check for sufficient flute length. Note: Special diameters available upon request.



Solid Carbide Drills

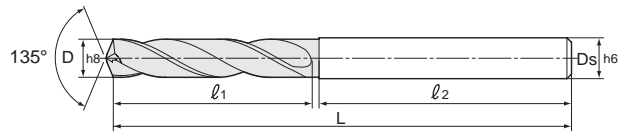
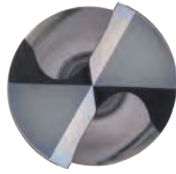

(continued from previous page)

MDW-GS4 4XD drill for excellent chip management and long tool life (External coolant)

Catalog Number (inch/metric)	Stock	Fractional Wire & Letters	Diameter D (in)	Diameter D (mm)	Overall Length L (in/mm)	Flute Length l_1 (in/mm)	Shank Length l_2 (in/mm)	Shank Diameter D_s (in/mm)	Tap Size
MDW02656GS4	●	17/64	0.2656	6.75	3.2677	1.6929	1.5748	0.2812	
MDW02660GS4	●	#H	0.2660	6.76	3.2677	1.6929	1.5748	0.2812	
MDW0680GS4	●		0.2677	6.80	83.0	43.0	40.0	7.0	
MDW0690GS4	●		0.2717	6.90	83.0	43.0	40.0	7.0	
MDW02720GS4	●	#I	0.2720	6.91	3.2677	1.6929	1.5748	0.2812	5/16-24
MDW0700GS4	●		0.2756	7.00	83.0	43.0	40.0	7.0	
MDW02770GS4	●	#J	0.2770	7.04	3.2677	1.6929	1.5748	0.2812	
MDW0710GS4	●		0.2795	7.10	90.0	45.0	43.0	8.0	
MDW02810GS4	●		0.2810	7.14	3.2677	1.6929	1.5748	0.2812	
MDW02812GS4	●	9/32	0.2812	7.142	3.2677	1.6929	1.5748	0.2812	
MDW0720GS4	●		0.2835	7.20	90.0	45.0	43.0	8.0	
MDW0730GS4	●		0.2874	7.30	90.0	45.0	43.0	8.0	
MDW02900GS4	●		0.2900	7.37	3.5433	1.7717	1.6929	0.3125	
MDW0740GS4	●		0.2913	7.40	90.0	45.0	43.0	8.0	
MDW02950GS4	●		0.2950	7.49	3.5433	1.7717	1.6929	0.3125	
MDW0750GS4	●		0.2953	7.50	90.0	45.0	43.0	8.0	
MDW02969GS4	●	19/64	0.2969	7.54	3.5433	1.8898	1.6535	0.3125	
MDW0760GS4	●		0.2992	7.60	90.0	48.0	42.0	8.0	
MDW03020GS4	●		0.3020	7.67	3.5433	1.8898	1.6535	0.3125	
MDW0770GS4	●		0.3031	7.70	90.0	48.0	42.0	8.0	
MDW0780GS4	●		0.3071	7.80	90.0	48.0	42.0	8.0	M9x1.25
MDW0790GS4	●		0.3110	7.90	90.0	48.0	42.0	8.0	
MDW03125GS4	●	5/16	0.3125	7.94	3.5433	1.8898	1.6535	0.3125	3/8-16
MDW0800GS4	●		0.3150	8.00	90.0	48.0	42.0	8.0	
MDW03160GS4	●		0.3160	8.03	3.8583	2.0866	1.6929	0.3594	
MDW0810GS4	●		0.3189	8.10	98.0	53.0	43.0	9.0	
MDW0820GS4	●		0.3228	8.20	98.0	53.0	43.0	9.0	
MDW03230GS4	●	#P	0.3230	8.204	3.8583	2.0866	1.6929	0.3594	
MDW0830GS4	●		0.3268	8.30	98.0	53.0	43.0	9.0	
MDW03281GS4	●	21/64	0.3281	8.33	3.8583	2.0866	1.6929	0.3594	
MDW0840GS4	●		0.3307	8.40	98.0	53.0	43.0	9.0	
MDW03320GS4	●	#Q	0.3320	8.43	3.8583	2.0866	1.6929	0.3594	
MDW0850GS4	●		0.3346	8.50	98.0	53.0	43.0	9.0	M10x1.5
MDW0860GS4	●		0.3386	8.60	98.0	55.0	43.0	9.0	
MDW03390GS4	●		0.3390	8.61	3.8583	2.1654	1.6929	0.3594	3/8-24
MDW0870GS4	●		0.3425	8.70	98.0	55.0	43.0	9.0	
MDW03438GS4	●	11/32	0.3438	8.73	3.8583	2.1654	1.6929	0.3594	
MDW0880GS4	●		0.3465	8.80	98.0	55.0	43.0	9.0	
MDW03480GS4	●		0.3480	8.84	3.8583	2.1654	1.6929	0.3594	
MDW0890GS4	●		0.3504	8.90	98.0	55.0	43.0	9.0	
MDW0900GS4	●		0.3543	9.00	98.0	55.0	43.0	9.0	
MDW03580GS4	●		0.3580	9.09	3.8583	2.1654	1.6929	0.3594	
MDW0910GS4	●		0.3583	9.10	105.0	58.0	45.0	10.0	
MDW03594GS4	●	23/64	0.3594	9.13	3.8583	2.1654	1.6929	0.3594	
MDW0920GS4	●		0.3622	9.20	105.0	58.0	45.0	10.0	
MDW0930GS4	●		0.3661	9.30	105.0	58.0	45.0	10.0	
MDW03680GS4	●	#U	0.3680	9.35	4.1339	2.2835	1.7717	0.3906	7/16-14
MDW0940GS4	●		0.3701	9.40	105.0	58.0	45.0	10.0	
MDW0950GS4	●		0.3740	9.50	105.0	58.0	45.0	10.0	
MDW03750GS4	●	3/8	0.3750	9.53	4.1339	2.3622	1.7717	0.3906	
MDW03770GS4	●		0.3770	9.58	4.1339	2.3622	1.7717	0.3906	
MDW0960GS4	●		0.3780	9.60	105.0	60.0	45.0	10.0	

●=USA stocked item

Some drills can achieve greater depths. Always check for sufficient flute length. Note: Special diameters available upon request.

(continued on next page)



SERIES MDW-GS4

MDW-GS4 Series Solid Carbide Drills

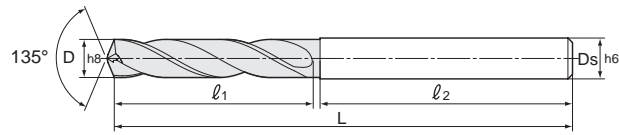
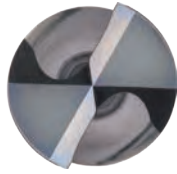

(continued from previous page)

MDW-GS4 4XD drill for excellent chip management and long tool life (External coolant)

Catalog Number (inch/metric)	Stock	Fractional Wire & Letters	Diameter D (in)	Diameter D (mm)	Overall Length L (in/mm)	Flute Length ℓ_1 (in/mm)	Shank Length ℓ_2 (in/mm)	Shank Diameter D _s (in/mm)	Tap Size
MDW0970GS4	●		0.3819	9.70	105.0	60.0	45.0	10.0	
MDW0980GS4	●		0.3858	9.80	105.0	60.0	45.0	10.0	
MDW03860GS4	●		0.3860	9.804	4.1339	2.3622	1.7717	0.3906	
MDW0990GS4	●		0.3898	9.90	105.0	60.0	45.0	10.0	
MDW03906GS4	●	25/64	0.3906	9.92	4.1339	2.3622	1.7717	0.3906	7/16-20
MDW1000GS4	●		0.3937	10.00	105.0	60.0	45.0	10.0	
MDW03970GS4	●		0.3970	10.08	4.4882	2.5984	1.8110	0.4375	
MDW1010GS4	●		0.3976	10.10	114.0	66.0	46.0	11.0	
MDW1020GS4	●		0.4016	10.20	114.0	66.0	46.0	11.0	M12x1.75
MDW04040GS4	●		0.4040	10.26	4.4882	2.5984	1.8110	0.4375	
MDW1030GS4	●		0.4055	10.30	114.0	66.0	46.0	11.0	
MDW04062GS4	●	13/32	0.4062	10.32	4.4882	2.5984	1.8110	0.4375	
MDW1040GS4	●		0.4094	10.40	114.0	66.0	46.0	11.0	
MDW04130GS4	●		0.4130	10.49	4.4882	2.5984	1.8110	0.4375	
MDW1050GS4	●		0.4134	10.50	114.0	66.0	46.0	11.0	
MDW1060GS4	●		0.4173	10.60	114.0	68.0	46.0	11.0	
MDW1070GS4	●		0.4213	10.70	114.0	68.0	46.0	11.0	
MDW04219GS4	●	27/64	0.4219	10.72	4.4882	2.6772	1.8110	0.4375	1/2-13
MDW1080GS4	●		0.4252	10.80	114.0	68.0	46.0	11.0	
MDW1090GS4	●		0.4291	10.90	114.0	68.0	46.0	11.0	
MDW1100GS4	●		0.4331	11.00	114.0	68.0	46.0	11.0	
MDW1110GS4	●		0.4370	11.10	121.0	71.0	48.0	12.0	
MDW04375GS4	●	7/16	0.4375	11.11	4.4882	2.6772	1.8110	0.4375	
MDW1120GS4	●		0.4409	11.20	121.0	71.0	48.0	12.0	
MDW1130GS4	●		0.4449	11.30	121.0	71.0	48.0	12.0	
MDW1140GS4	●		0.4488	11.40	121.0	71.0	48.0	12.0	
MDW1150GS4	●		0.4528	11.50	121.0	71.0	48.0	12.0	
MDW04531GS4	●	29/64	0.4531	11.51	4.7638	2.8740	1.8898	0.4688	1/2-20
MDW1160GS4	●		0.4567	11.60	121.0	73.0	48.0	12.0	
MDW1170GS4	●		0.4606	11.70	121.0	73.0	48.0	12.0	
MDW1180GS4	●		0.4646	11.80	121.0	73.0	48.0	12.0	
MDW1190GS4	●		0.4685	11.90	121.0	73.0	48.0	12.0	
MDW04688GS4	●	15/32	0.4688	11.91	4.7638	2.8740	1.8898	0.4688	
MDW1200GS4	●		0.4724	12.00	121.0	73.0	48.0	12.0	M14x2
MDW1210GS4	●		0.4764	12.10	137.0	76.0	59.0	13.0	
MDW1220GS4	●		0.4803	12.20	137.0	76.0	59.0	13.0	
MDW1230GS4	●		0.4843	12.30	137.0	76.0	59.0	13.0	9/16-12
MDW04844GS4	●	31/64	0.4844	12.308	5.3937	2.9921	2.3228	0.5156	
MDW1240GS4	●		0.4882	12.40	137.0	76.0	59.0	13.0	
MDW1250GS4	●		0.4921	12.50	137.0	76.0	59.0	13.0	
MDW1260GS4	●		0.4961	12.60	137.0	78.0	59.0	13.0	
MDW1270GS4	●	1/2	0.5000	12.70	137.0	78.0	59.0	13.0	
MDW05000GS4	●	1/2	0.5000	12.70	5.3937	3.0709	2.3228	0.5156	
MDW1280GS4	●		0.5039	12.80	137.0	78.0	59.0	13.0	
MDW05050GS4	●		0.5050	12.83	5.3937	3.0709	2.3228	0.5156	
MDW1290GS4	●		0.5079	12.90	137.0	78.0	59.0	13.0	
MDW1300GS4	●		0.5118	13.00	137.0	78.0	59.0	13.0	
MDW05156GS4	●	33/64	0.5156	13.09	5.3937	3.0709	2.3228	0.5156	9/16-18
MDW1310GS4	●		0.5157	13.10	147.0	84.0	61.0	14.0	
MDW1320GS4	●		0.5197	13.20	147.0	84.0	61.0	14.0	
MDW1330GS4	●		0.5236	13.30	147.0	84.0	61.0	14.0	
MDW1340GS4	●		0.5276	13.40	147.0	84.0	61.0	14.0	

● = USA stocked item

Some drills can achieve greater depths. Always check for sufficient flute length. Note: Special diameters available upon request.

(continued on next page)



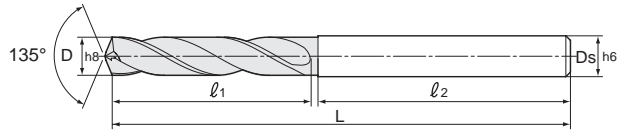
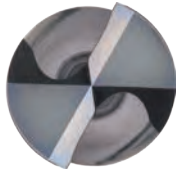

(continued from previous page)

MDW-GS4 4XD drill for excellent chip management and long tool life (External coolant)

Catalog Number (inch/metric)	Stock	Fractional Wire & Letters	Diameter D (in)	Diameter D (mm)	Overall Length L (in/mm)	Flute Length l_1 (in/mm)	Shank Length l_2 (in/mm)	Shank Diameter D_s (in/mm)	Tap Size
MDW05312GS4	●	17/32	0.5312	13.49	5.7874	3.3071	2.4016	0.5469	5/8-11
MDW1350GS4	●		0.5315	13.50	147.0	84.0	61.0	14.0	
MDW1360GS4	●		0.5354	13.60	147.0	86.0	61.0	14.0	
MDW1370GS4	●		0.5394	13.70	147.0	86.0	61.0	14.0	
MDW1380GS4	●		0.5433	13.80	147.0	86.0	61.0	14.0	
MDW05469GS4	●	35/64	0.5469	13.89	5.7874	3.3858	2.4016	0.5469	M16x2
MDW1390GS4	●		0.5472	13.90	147.0	86.0	61.0	14.0	
MDW1400GS4	●		0.5512	14.00	147.0	86.0	61.0	14.0	
MDW1410GS4	●		0.5551	14.10	153.0	89.0	62.0	15.0	
MDW1420GS4	●		0.5591	14.20	153.0	89.0	62.0	15.0	
MDW05625GS4	●	9/16	0.5625	14.29	6.0236	3.5039	2.4409	0.5937	
MDW1430GS4	●		0.5630	14.30	153.0	89.0	62.0	15.0	
MDW1440GS4	●		0.5669	14.40	153.0	89.0	62.0	15.0	
MDW1450GS4	●		0.5709	14.50	153.0	89.0	62.0	15.0	
MDW1460GS4	●		0.5748	14.60	153.0	91.0	62.0	15.0	
MDW05781GS4	●	37/64	0.5781	14.68	6.0236	3.5827	2.4409	0.5937	5/8-18
MDW1470GS4	●		0.5787	14.70	153.0	91.0	62.0	15.0	
MDW1480GS4	●		0.5827	14.80	153.0	91.0	62.0	15.0	
MDW1490GS4	●		0.5866	14.90	153.0	91.0	62.0	15.0	
MDW1500GS4	●		0.5906	15.00	153.0	91.0	62.0	15.0	
MDW05937GS4	●	19/32	0.5937	15.08	6.0236	3.5827	2.4409	0.5937	
MDW1510GS4	●		0.5945	15.10	160.0	94.0	64.0	16.0	
MDW1520GS4	●		0.5984	15.20	160.0	94.0	64.0	16.0	
MDW1530GS4	●		0.6024	15.30	160.0	94.0	64.0	16.0	
MDW1540GS4	●		0.6063	15.40	160.0	94.0	64.0	16.0	
MDW06094GS4	●	39/64	0.6094	15.48	6.2992	3.7008	2.5197	0.6250	11/16-12
MDW1550GS4	●		0.6102	15.50	160.0	94.0	64.0	16.0	M18x2.5
MDW1560GS4	●		0.6142	15.60	160.0	96.0	64.0	16.0	
MDW1570GS4	●		0.6181	15.70	160.0	96.0	64.0	16.0	
MDW1580GS4	●		0.6220	15.80	160.0	96.0	64.0	16.0	
MDW06250GS4	●	5/8	0.6250	15.88	6.2992	3.7795	2.5197	0.6250	11/16-16
MDW1590GS4	●		0.6260	15.90	160.0	96.0	64.0	16.0	
MDW1600GS4	●		0.6299	16.00	160.0	96.0	64.0	16.0	
MDW06406GS4	●	41/64	0.6406	16.27	6.575	3.858	2.559	0.669	
MDW1650GS4	●		0.6496	16.50	167	98	65	17	
MDW06562GS4	●	21/32	0.6562	16.67	6.575	3.858	2.559	0.669	3/4-10
MDW1700GS4	●		0.6693	17.00	167	98	65	17	
MDW06875GS4	●	11/16	0.6875	17.46	6.575	3.937	2.559	0.709	3/4-16
MDW1750GS4	★		0.6890	17.50	167	100	65	18	
MDW07031GS4	●	45/64	0.7031	17.86	6.575	4.016	2.559	0.709	
MDW1800GS4	●		0.7087	18.00	167	102	65	18	
MDW07187GS4	●	23/32	0.7187	18.25	7.047	4.094	2.559	0.748	
MDW1850GS4	★		0.7283	18.50	179	104	65	19	
MDW07344GS4	●	47/64	0.7344	18.65	7.047	4.173	2.559	0.748	7/8-9
MDW1900GS4	★		0.7480	19.00	179	106	65	19	
MDW07500GS4	●	3/4	0.7500	19.05	7.047	4.331	2.559	0.787	
MDW1950GS4	★		0.7677	19.50	179	110	65	20	
MDW07812GS4	●	25/32	0.7812	19.84	7.047	4.488	2.559	0.787	
MDW2000GS4	★		0.7874	20.00	179	114	65	20	

●=USA stocked item

Some drills can achieve greater depths. Always check for sufficient flute length. Note: Special diameters available upon request.

■ = Product expansion



MDW-HGS3 Series Solid Carbide Coolant Through Drills

SERIES MDW-HGS3

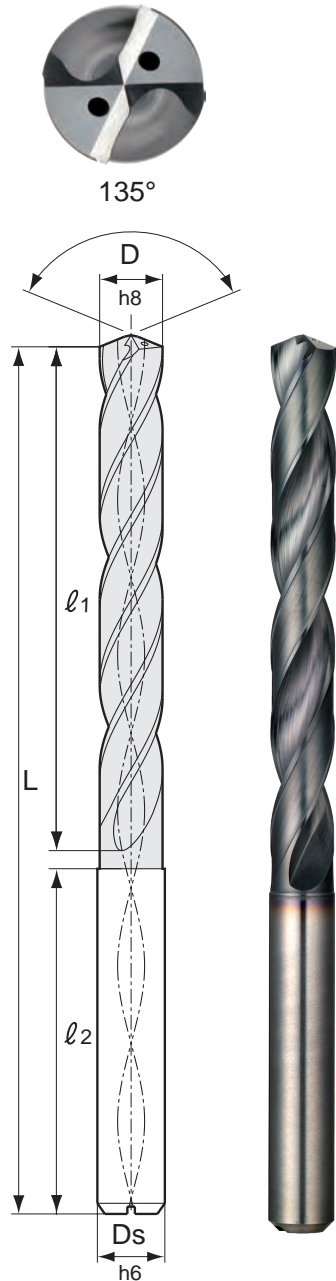
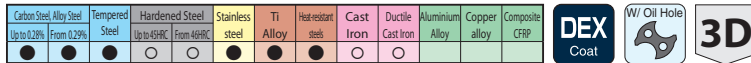

Items labeled in purple represent drills that fit in Shrink Fit Holders

Catalog Number (inch/metric)	Type	Stock	D _c mm	D _c Inch	Shank Diameter D _s (in/mm)	Overall Length L (in/mm)	Flute Length ℓ ₁ (in/mm)	Shank Length ℓ ₂ (in/mm)	Tap Size	Fractional Wire & Letters
MDW0440	HGS3 HGS3S	●	4.40	0.173	5.0 6.0	80.0	25	53		
MDW0450	HGS3 HGS3S	●	4.50	0.177	5.0 6.0	80.0	25	53		
MDW0460	HGS3 HGS3S	●	4.60	0.181	5.0 6.0	80.0	27.5	51		
MDW0470	HGS3 HGS3S	●	4.70	0.185	5.0 6.0	80.0	27.5	51		
MDW01875	HGS3 HGS3S	●	4.76	0.188	0.188 6.0	3.10	1.083	2.008		3/16
MDW0480	HGS3 HGS3S	●	4.80	0.189	5.0 6.0	80.0	27.5	51		
MDW0490	HGS3 HGS3S	●	4.90	0.193	5.0 6.0	80.0	27.5	51		
MDW0500	HGS3 HGS3S	●	5.00	0.197	5.0 6.0	80.0	27.5	51	M6x1	
MDW0510	HGS3 HGS3S	●	5.10	0.201	6.0	82.0	27.5	53		
MDW02010	HGS3 HGS3S	●	5.11	0.201	0.234 6.0	3.228	1.083	2.087	1/4-2020	#7
MDW02031	HGS3 HGS3S	●	5.16	0.203	0.234 6.0	3.228	1.083	2.087		13/64
MDW0520	HGS3 HGS3S	●	5.20	0.205	6.0	82.0	27.5	53		
MDW0530	HGS3 HGS3S	●	5.30	0.209	6.0	82.0	27.5	53		
MDW0540	HGS3 HGS3S	●	5.40	0.213	6.0	82.0	27.5	53		
MDW02130	HGS3 HGS3S	●	5.41	0.213	0.234 6.0	3.228	1.083	2.087		#3
MDW0550	HGS3 HGS3S	●	5.50	0.217	6.0	82.0	27.5	53		
MDW02188	HGS3 HGS3S	●	5.56	0.219	0.234 6.0	3.228	1.181	2.047	1/4-2028	7/32
MDW0560	HGS3 HGS3S	●	5.60	0.221	6.0	82.0	30	52		
MDW02210	HGS3 HGS3S	●	5.61	0.221	0.234 6.0	3.228	1.181	2.047		#2
MDW0570	HGS3 HGS3S	●	5.70	0.224	6.0	82.0	30	52		
MDW0580	HGS3 HGS3S	●	5.80	0.228	6.0	82.0	30	52		
MDW0590	HGS3 HGS3S	●	5.90	0.232	6.0	82.0	30	52		
MDW02344	HGS3 HGS3S	●	5.995	0.234	0.234 6.0	3.228	1.181	2.047		15/64
MDW0600	HGS3 HGS3S	●	6.00	0.236	6.0	82.0	30	52	M7x1	
MDW0610	HGS3 HGS3S	●	6.10	0.240	7.0 8.0	88.0	32.5	53		
MDW02420	HGS3 HGS3S	●	6.15	0.242	0.281 8.0	3.465	1.280	2.087		#C
MDW0620	HGS3 HGS3S	●	6.20	0.244	7.0 8.0	88.0	32.5	53		
MDW0630	HGS3 HGS3S	●	6.30	0.248	7.0 8.0	88.0	32.5	53		
MDW02500	HGS3 HGS3S	●	6.35	0.250	0.281 8.0	3.465	1.280	2.087		1/4
MDW0640	HGS3 HGS3S	●	6.40	0.252	7.0 8.0	88.0	32.5	53		
MDW0650	HGS3 HGS3S	●	6.50	0.256	7.0 8.0	88.0	32.5	53		
MDW02570	HGS3 HGS3S	●	6.53	0.257	0.281 8.0	3.465	1.378	2.087	5/16-18	#F
MDW0660	HGS3 HGS3S	●	6.60	0.260	7.0 8.0	88.0	35	53		
MDW0670	HGS3 HGS3S	●	6.70	0.264	7.0 8.0	88.0	35	53		
MDW02656	HGS3 HGS3S	●	6.75	0.266	0.281 8.0	3.465	1.378	2.087		17/64



Carbon Steel	Alloy Steel	Tempered Steel	Hardened Steel	Stainless Steel	Ti Alloy	Heat-treatable	Cast Iron	Ductile Cast Iron	Aluminum Alloy	Copper alloy	Composite CFRP
●	●	●	○	○	●	●	○	○	○	○	○
Up to 0.28%	From 0.29%		Up to 45RC	From 48RC							



135°

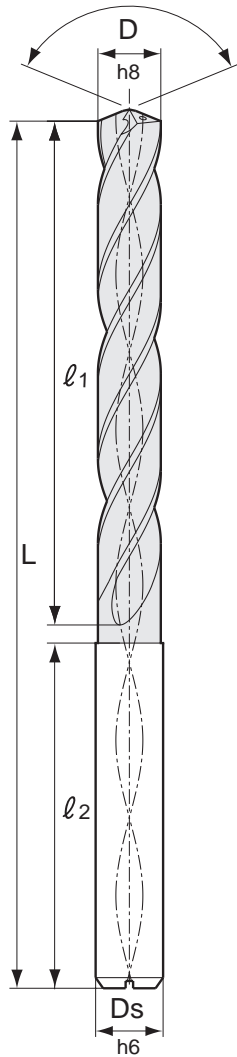

Items labeled in purple represent drills that fit in Shrink Fit Holders

Catalog Number (inch/metric)	Type	Stock	D _c mm	D _c Inch	Shank Diameter D _s (in/mm)	Overall Length L (in/mm)	Flute Length ℓ ₁ (in/mm)	Shank Length ℓ ₂ (in/mm)	Tap Size	Fractional Wire & Letters
MDW02660	HGS3	●	6.76	0.266	0.281	3.465	1.378	2.087		
	HGS3S	●			8.0					
MDW0680	HGS3	●	6.80	0.268	7.0	88.0	35	53		
	HGS3S	●			8.0					
MDW0690	HGS3	●	6.90	0.272	7.0	88.0	35	53		
	HGS3S	●			8.0					
MDW02720	HGS3	●	6.91	0.272	0.281	3.465	1.378	2.087	5/16-24	#I
	HGS3S	●			8.0					
MDW0700	HGS3	●	7.00	0.276	7.0	88.0	35	53		
	HGS3S	●			8.0					
MDW02770	HGS3	●	7.04	0.277	0.281	3.465	1.378	2.087		#J
	HGS3S	●			8.0					
MDW0710	HGS3	●	7.10	0.280	8.0	94.0	37.5	54		
	HGS3S	●			8.0					
MDW02812	HGS3	●	7.14	0.281	0.281	3.465	1.378	2.087		9/32
	HGS3S	●			8.0					
MDW0720	HGS3	●	7.20	0.284	8.0	94.0	37.5	54		
	HGS3S	●			8.0					
MDW0730	HGS3	●	7.30	0.287	8.0	94.0	37.5	54		
	HGS3S	●			8.0					
MDW0740	HGS3	●	7.40	0.291	8.0	94.0	37.5	54		
	HGS3S	●			8.0					
MDW0750	HGS3	●	7.50	0.295	8.0	94.0	37.5	54		
	HGS3S	●			8.0					
MDW02969	HGS3	●	7.54	0.297	0.313	3.701	1.575	2.126		19/64
	HGS3S	●			8.0					
MDW0760	HGS3	●	7.60	0.299	8.0	94.0	40	54		
	HGS3S	●			8.0					
MDW0770	HGS3	●	7.70	0.303	8.0	94.0	40	54		
	HGS3S	●			8.0					
MDW0780	HGS3	●	7.80	0.307	8.0	94.0	40	54	M9x1.25	
	HGS3S	●			8.0					
MDW0790	HGS3	●	7.90	0.311	8.0	94.0	40	54		
	HGS3S	●			8.0					
MDW03125	HGS3	●	7.94	0.313	0.313	3.701	1.575	2.126	3/8-16	5/16
	HGS3S	●			8.0					
MDW0800	HGS3	●	8.00	0.315	8.0	94.0	40	54		
	HGS3S	●			8.0					
MDW0810	HGS3	●	8.10	0.319	9.0	100.0	42.5	55		
	HGS3S	●			10.0					
MDW0820	HGS3	●	8.20	0.323	9.0	100.0	42.5	55		
	HGS3S	●			10.0					
MDW03230	HGS3	●	8.204	0.323	0.359	3.937	1.673	2.165		#P
	HGS3S	●			10.0					
MDW0830	HGS3	●	8.30	0.327	9.0	100.0	42.5	55		
	HGS3S	●			10.0					
MDW03281	HGS3	●	8.33	0.328	0.359	3.937	1.673	2.165	M7x1	21/64
	HGS3S	●			10.0					
MDW0840	HGS3	●	8.40	0.331	9.0	100.0	42.5	55		
	HGS3S	●			10.0					
MDW03320	HGS3	●	8.43	0.332	0.359	3.937	1.673	2.165		#Q
	HGS3S	●			10.0					
MDW0850	HGS3	●	8.50	0.335	9.0	100.0	42.5	55	M10x1.5	
	HGS3S	●			10.0					
MDW0860	HGS3	●	8.60	0.339	9.0	100.0	45	55		
	HGS3S	●			10.0					
MDW0870	HGS3	●	8.70	0.343	9.0	100.0	45	55		
	HGS3S	●			10.0					
MDW03438	HGS3	●	8.73	0.344	0.359	3.937	1.772	2.165		11/32
	HGS3S	●			10.0					
MDW0880	HGS3	●	8.80	0.347	9.0	100.0	45	55		
	HGS3S	●			10.0					
MDW0890	HGS3	●	8.90	0.350	9.0	100.0	45	55		
	HGS3S	●			10.0					
MDW0900	HGS3	●	9.00	0.354	9.0	100.0	45	55		
	HGS3S	●			10.0					
MDW0910	HGS3	●	9.10	0.358	10.0	106.0	47.5	56		
	HGS3S	●			10.0					
MDW03594	HGS3	●	9.13	0.359	0.359	3.937	1.772	2.165		23/64
	HGS3S	●			10.0					



MDW-HGS3 Series Solid Carbide Coolant Through Drills

SERIES MDW-HGS3

Carbon Steel Alloy Steel Up to 0.28% From 0.29%	Tempered Steel	Hardened Steel Up to 45HRC From 46HRC	Stainless steel	Ti Alloy	Heat-resistant steel	Cast Iron	Ductile Cast Iron	Aluminium Alloy	Copper alloy	Composite CFRP	DEX Coat	W/Oil Hole	3D
---	----------------	---	-----------------	----------	----------------------	-----------	-------------------	-----------------	--------------	----------------	----------	------------	----

Items labeled in purple represent drills that fit in Shrink Fit Holders

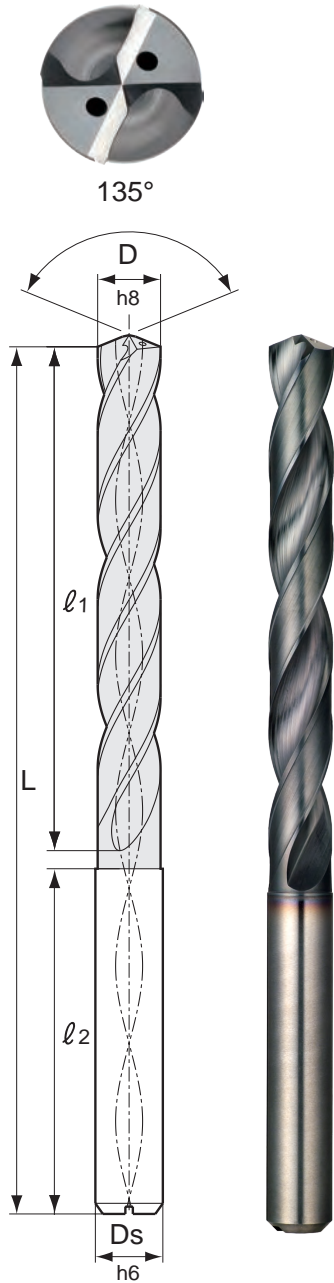

Catalog Number (inch/metric) Ex: MDW0900HGS3 or MDW0900HGS3S	Type	Stock	D _c mm	D _c Inch	Shank Diameter D _s (in/mm)	Overall Length L (in/mm)	Flute Length ℓ ₁ (in/mm)	Shank Length ℓ ₂ (in/mm)	Tap Size	Fractional Wire & Letters
MDW0920	HGS3 HGS3S	●	9.2	0.362	10.0	106	47.5	56		
MDW0930	HGS3 HGS3S	●	9.3	0.366	10.0	106	47.5	56		
MDW03680	HGS3 HGS3S	●	9.35	0.368	0.391 10.0	4.173	1.870	2.205	7/16-14	#U
MDW0940	HGS3 HGS3S	●	9.4	0.370	10.0	106	47.5	56		
MDW0950	HGS3 HGS3S	●	9.5	0.374	10.0	106	47.5	56		
MDW03750	HGS3 HGS3S	●	9.53	0.375	0.391 10.0	4.173	1.969	2.205		3/8
MDW0960	HGS3 HGS3S	●	9.6	0.378	10.0	106	50	56		
MDW0970	HGS3 HGS3S	●	9.7	0.382	10.0	106	50	56		
MDW0980	HGS3 HGS3S	●	9.8	0.386	10.0	106	50	56		
MDW0990	HGS3 HGS3S	●	9.9	0.390	10.0	106	50	56		
MDW03906	HGS3 HGS3S	●	9.92	0.391	0.391 10.0	4.173	1.969	2.205	7/16-20	25/64
MDW1000	HGS3 HGS3S	●	10.0	0.394	10.0	106	50	56		
MDW1010	HGS3 HGS3S	●	10.1	0.398	11.0 12.0	116	52.5	61		
MDW1020	HGS3 HGS3S	●	10.2	0.402	11.0 12.0	116	52.5	61	M12x1.75	
MDW1030	HGS3 HGS3S	●	10.3	0.406	11.0 12.0	116	52.5	61		
MDW4062	HGS3 HGS3S	●	10.32	0.406	0.438 12.0	4.567	2.067	2.402		13/32
MDW1040	HGS3 HGS3S	●	10.4	0.409	11.0 12.0	116	52.5	61		
MDW1050	HGS3 HGS3S	●	10.5	0.413	11.0 12.0	116	52.5	61		
MDW1060	HGS3 HGS3S	●	10.6	0.417	11.0 12.0	116	55	61		
MDW1070	HGS3 HGS3S	●	10.7	0.421	11.0 12.0	116	55	61		
MDW04219	HGS3 HGS3S	●	10.72	0.422	0.438 12.0	4.567	2.165	2.402	1/2-13	27/64
MDW1080	HGS3 HGS3S	●	10.8	0.425	11.0 12.0	116	55	61		
MDW1090	HGS3 HGS3S	●	10.9	0.429	11.0 12.0	116	55	61		
MDW1100	HGS3 HGS3S	●	11.0	0.433	11.0 12.0	116	55	61		
MDW1110	HGS3 HGS3S	●	11.1	0.437	12.0	122	57.5	62		
MDW04375	HGS3 HGS3S	●	11.11	0.438	0.438 12.0	4.567	2.165	2.402		7/16
MDW1120	HGS3 HGS3S	●	11.2	0.441	12.0	122	57.5	62		
MDW1130	HGS3 HGS3S	●	11.3	0.445	12.0	122	57.5	62		
MDW1140	HGS3 HGS3S	●	11.4	0.449	12.0	122	57.5	62		
MDW1150	HGS3 HGS3S	●	11.5	0.453	12.0	122	57.5	62		
MDW04531	HGS3 HGS3S	●	11.51	0.453	0.469 12.0	4.803	2.362	2.441	1/2-20	29/64
MDW1160	HGS3 HGS3S	●	11.6	0.457	12.0	122	60	62		
MDW1170	HGS3 HGS3S	●	11.7	0.461	12.0	122	60	62		
MDW1180	HGS3 HGS3S	●	11.8	0.465	12.0	122	60	62		
MDW1190	HGS3 HGS3S	●	11.9	0.469	12.0	122	60	62		
MDW04688	HGS3 HGS3S	●	11.91	0.469	0.469 12.0	4.803	2.362	2.441		15/32



Carbon Steel	Alloy Steel	Tempered Steel	Hardened Steel	Stainless Steel	Ti Alloy	Heat-resistant steel	Cast Iron	Ductile Cast Iron	Aluminum Alloy	Copper alloy	Composite CFRP
●	●	●	○	○	●	●	○	○	○	○	○
Up to 0.28%	From 0.2%	Steel	Up to 49RC	From 49RC							

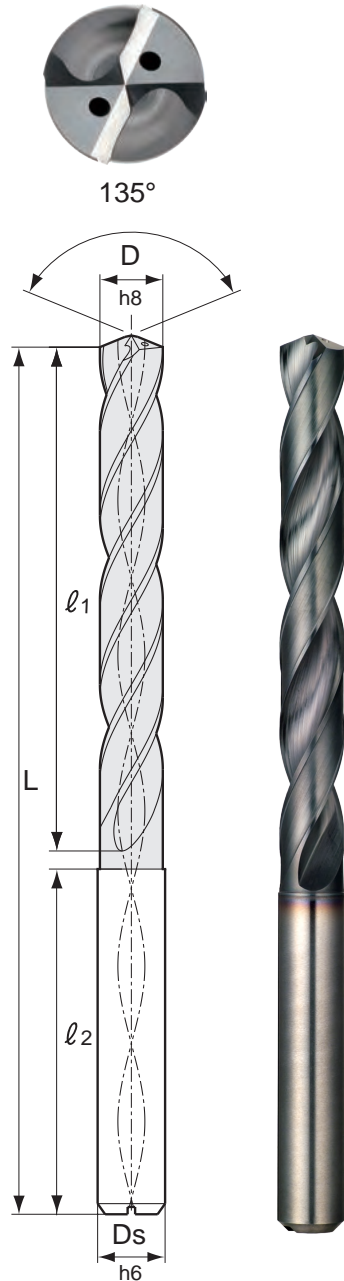

Items labeled in purple represent drills that fit in Shrink Fit Holders

Catalog Number (inch/metric)	Type	Stock	D _c mm	D _c Inch	Shank Diameter D _s (in/mm)	Overall Length L (in/mm)	Flute Length l ₁ (in/mm)	Shank Length l ₂ (in/mm)	Tap Size	Fractional Wire & Letters
MDW1200	HGS3 HGS3S	●	12.0	0.472	12.0	122	60	62		
MDW1210	HGS3 HGS3S	●	12.1	0.476	13.0 14.0	128	62.5	63		
MDW1220	HGS3 HGS3S	●	12.2	0.480	13.0 14.0	128	62.5	63		
MDW1230	HGS3 HGS3S	●	12.3	0.484	13.0 14.0	128	65	63	9/16-12	
MDW04844	HGS3 HGS3S	●	12.31	0.484	0.516 14.0	5.039	2.461	2.480		31/64
MDW1240	HGS3 HGS3S	●	12.4	0.488	13.0 14.0	128	62.5	63		
MDW1250	HGS3 HGS3S	●	12.5	0.492	13.0 14.0	128	62.5	63		
MDW1260	HGS3 HGS3S	●	12.6	0.496	13.0 14.0	128	65	63		
MDW1270	HGS3 HGS3S	●	12.7	0.500	13.0 14.0	128	65	63		1/2
MDW05000	HGS3 HGS3S	●	12.7	0.500	0.516 14.0	5.039	2.559	2.480		1/2
MDW1280	HGS3 HGS3S	●	12.8	0.504	13.0 14.0	128	65	63		
MDW1290	HGS3 HGS3S	●	12.9	0.508	13.0 14.0	128	65	63		
MDW1300	HGS3 HGS3S	●	13.0	0.512	13.0 14.0	128	65	63		
MDW05156	HGS3 HGS3S	●	13.09	0.516	0.516 14.0	5.039	2.559	2.480	9/16-18	33/64
MDW1310	HGS3 HGS3S	●	13.1	0.516	14.0	134	67.5	64		
MDW1320	HGS3 HGS3S	●	13.2	0.520	14.0	134	67.5	64		
MDW1330	HGS3 HGS3S	●	13.3	0.524	14.0	134	67.5	64		
MDW1340	HGS3 HGS3S	●	13.4	0.528	14.0	134	67.5	64		
MDW05312	HGS3 HGS3S	●	13.49	0.531	0.547 14.0	5.276	2.658	2.520	5/8-11	17/32
MDW1350	HGS3 HGS3S	●	13.5	0.532	14.0	134	67.5	64		
MDW1360	HGS3 HGS3S	●	13.6	0.535	14.0	134	70	64		
MDW1370	HGS3 HGS3S	●	13.7	0.539	14.0	134	70	64		
MDW1380	HGS3 HGS3S	●	13.8	0.543	14.0	134	70	64		
MDW05469	HGS3 HGS3S	●	13.89	0.547	0.547 14.0	5.276	2.756	2.520	M16x2	35/64
MDW1390	HGS3 HGS3S	●	13.9	0.547	14.0	134	70	64		
MDW1400	HGS3 HGS3S	●	14.0	0.551	14.0	134	70	64		
MDW1410	HGS3 HGS3S	●	14.1	0.555	15.0 16.0	140	72.5	65		
MDW1420	HGS3 HGS3S	●	14.2	0.559	15.0 16.0	140	72.5	65		
MDW05625	HGS3 HGS3S	●	14.29	0.563	0.594 16.0	5.512	2.854	2.559		9/16
MDW1430	HGS3 HGS3S	●	14.3	0.563	15.0 16.0	140	72.5	65		
MDW1440	HGS3 HGS3S	●	14.4	0.567	15.0 16.0	140	72.5	65		
MDW1450	HGS3 HGS3S	●	14.5	0.571	15.0 16.0	140	72.5	65		
MDW1460	HGS3 HGS3S	●	14.6	0.575	15.0 16.0	140	75	65		
MDW05781	HGS3 HGS3S	●	14.68	0.578	0.594 16.0	5.512	2.953	2.559	5/8-18	37/64
MDW1470	HGS3 HGS3S	●	14.7	0.579	15.0 16.0	140	75	65		

Solid Carbide Drills



MDW-HGS3 Series Solid Carbide Coolant Through Drills

SERIES MDW-HGS3

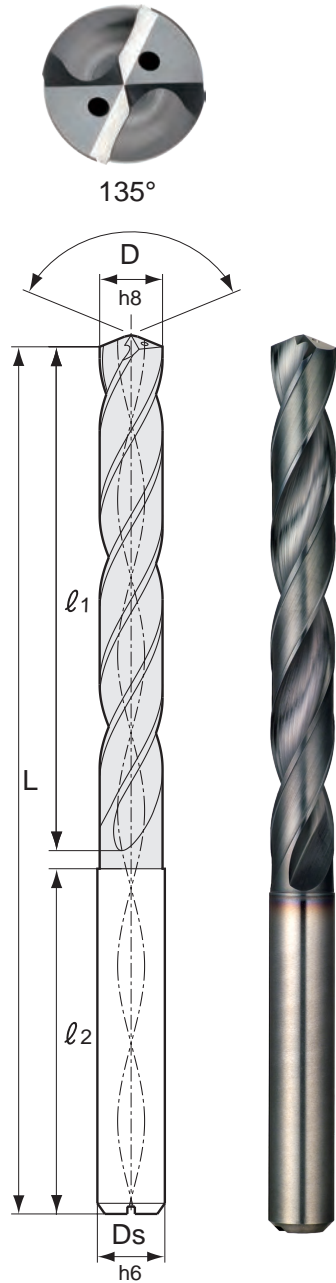
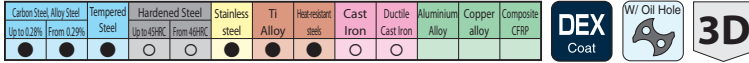

Items labeled in purple represent drills that fit in Shrink Fit Holders

Catalog Number (inch/metric)	Type	Stock	D _c mm	D _c Inch	Shank Diameter D _s (in/mm)	Overall Length L (in/mm)	Flute Length l ₁ (in/mm)	Shank Length l ₂ (in/mm)	Tap Size	Fractional Wire & Letters
MDW1480	HGS3	●	14.8	0.583	15.0	140	75	65		
	HGS3S	●			16.0					
MDW1490	HGS3	●	14.9	0.587	15.0	140	75	65		
	HGS3S	●			16.0					
MDW1500	HGS3	●	15.0	0.591	15.0	140	75	65		
	HGS3S	●			16.0					
MDW05937	HGS3	●	15.08	0.594	0.594	5.515	2.953	2.559		19/32
	HGS3S	●			16.0					
MDW1510	HGS3	●	15.1	0.595	16.0	146	77.5	66		
	HGS3S	●			16.0					
MDW1520	HGS3	●	15.2	0.598	16.0	146	77.5	66		
	HGS3S	●			16.0					
MDW1530	HGS3	●	15.3	0.602	16.0	146	77.5	66		
	HGS3S	●			16.0					
MDW1540	HGS3	●	15.4	0.606	16.0	146	77.5	66		
	HGS3S	●			16.0					
MDW06094	HGS3	●	15.48	0.609	0.625	5.748	3.051	2.598	11/16-12	39/64
	HGS3S	●			16.0					
MDW1550	HGS3	●	15.5	0.610	16.0	146	77.5	66	M18x2.5	
	HGS3S	●			16.0					
MDW1560	HGS3	●	15.6	0.614	16.0	146	80	66		
	HGS3S	●			16.0					
MDW1570	HGS3	●	15.7	0.618	16.0	146	80	66		
	HGS3S	●			16.0					
MDW1580	HGS3	●	15.8	0.622	16.0	146	80	66		
	HGS3S	●			16.0					
MDW06250	HGS3	●	15.88	0.625	0.625	5.748	3.150	2.598	11/16-16	5/8
	HGS3S	●			16.0					
MDW1590	HGS3	●	15.9	0.626	16.0	146	80	66		
	HGS3S	●			16.0					
MDW1600	HGS3	●	16.0	0.630	16.0	146	80	66		
	HGS3S	●			16.0					
MDW06406	HGS3	●	16.27	0.641	0.669	5.984	3.248	2.638		41/64
	HGS3S	●			16.0					
MDW1650	HGS3	●	16.5	0.650	17.0	152	82.5	67		
	HGS3S	●			16.0					
MDW06562	HGS3	●	16.67	0.656	0.672	5.984	3.346	2.638	3/4-10	21/32
	HGS3S	●			16.0					
MDW1700	HGS3	●	17.0	0.669	17.0	152	85	67		
	HGS3S	●			16.0					
MDW06875	HGS3	●	17.46	0.687	0.709	6.220	3.445	2.677	3/4-16	11/16
	HGS3S	●			16.0					
MDW1750	HGS3	●	17.5	0.689	17.0	158	87.5	68		
	HGS3S	●			16.0					
MDW07031	HGS3	●	17.86	0.703	0.709	6.220	3.543	2.677		45/64
	HGS3S	●			16.0					
MDW1800	HGS3	★	18.0	0.709	18.0	158	90	68		
	HGS3S	●			16.0					
MDW07187	HGS3	●	18.25	0.719	0.748	6.457	3.642	2.717		23/32
	HGS3S	●			16.0					
MDW1850	HGS3	★	18.5	0.728	18.0	164	92.5	69		
	HGS3S	●			16.0					
MDW07344	HGS3	●	18.65	0.734	0.748	6.457	3.740	2.717	7/8-9	47/64
	HGS3S	●			16.0					
MDW1900	HGS3	●	19.0	0.748	19.0	164	95	69		
	HGS3S	●			16.0					
MDW07500	HGS3	●	19.05	0.750	0.787	6.693	3.839	2.756		3/4
	HGS3S	●			16.0					
MDW1925	HGS3	●	19.25	0.748	20.0	170	97.5	70		72/95
	HGS3S	●			16.0					
MDW1950	HGS3	★	19.5	0.768	20.0	170	97.5	70		
	HGS3S	●			16.0					
MDW07812	HGS3	●	19.84	0.781	0.787	6.693	3.937	2.756		25/32
	HGS3S	●			16.0					
MDW2000	HGS3	★	20.0	0.787	20.0	170	100	70		
	HGS3S	●			16.0					



Items labeled in purple represent drills that fit in Shrink Fit Holders

Carbon Steel, Alloy Steel Up to 0.28% C From 0.29% C	Tempered Steel	Hardened Steel Up to 45HRC From 46HRC	Stainless steel	Ti Alloy	Heat-resistant steel	Cast Iron	Ductile Cast Iron	Aluminum Alloy	Copper alloy	Composite CFRP	DEX Coat	W/Oil Hole	5D
---	----------------	--	-----------------	----------	----------------------	-----------	-------------------	----------------	--------------	----------------	----------	------------	----

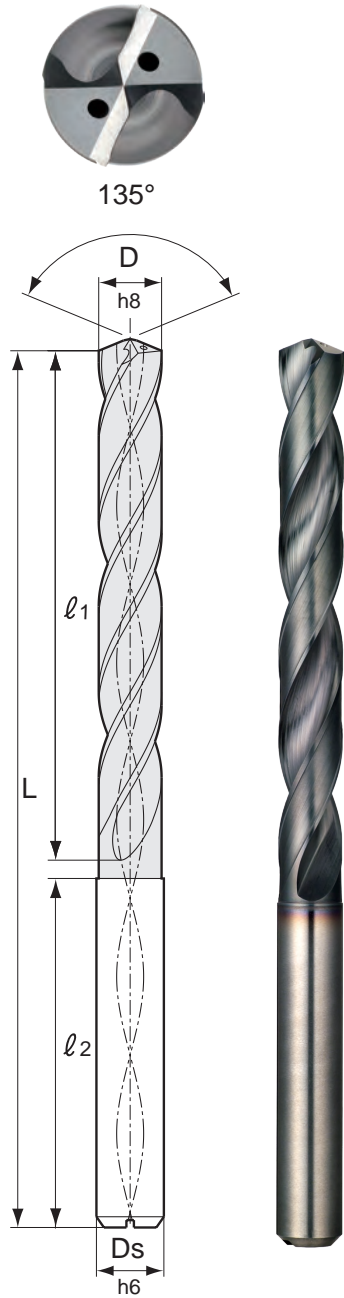

Solid Carbide Drills

Catalog Number (inch/metric) Ex: MDW0900HGS5 or MDW0900HGS5S	Type	Stock	D _C mm	D _C Inch	Shank Diameter D _S (in/mm)	Overall Length L (in/mm)	Flute Length l ₁ (in/mm)	Shank Length l ₂ (in/mm)	Tap Size	Fractional Wire & Letters
MDW0150	HGS5 HGS5S	●	1.50	0.059	3.0	70	14	56		
MDW0160	HGS5 HGS5S	●	1.60	0.063	3.0	70	19	51		
MDW0170	HGS5 HGS5S	●	1.70	0.067	3.0	70	19	51		
MDW0180	HGS5 HGS5S	●	1.80	0.071	3.0	70	19	51		
MDW0190	HGS5 HGS5S	●	1.90	0.075	3.0	70	19	51		
MDW0200	HGS5 HGS5S	●	2.00	0.079	3.0	70	19	49		
MDW0210	HGS5 HGS5S	●	2.10	0.083	3.0	78	24	52		
MDW0220	HGS5 HGS5S	●	2.20	0.087	3.0	78	24	52		
MDW0230	HGS5 HGS5S	●	2.30	0.091	3.0	78	24	52		
MDW00937	HGS5 HGS5S	●	2.38	0.094	.125 3.0	3.07	0.945	1.889		3/32
MDW0240	HGS5 HGS5S	●	2.40	0.095	3.0	78	24	52		
MDW0250	HGS5 HGS5S	●	2.50	0.098	3.0	78	24	52		
MDW0260	HGS5 HGS5S	●	2.60	0.102	3.0	78	28	48		
MDW0270	HGS5 HGS5S	●	2.70	0.106	3.0	78	28	48		
MDW01094	HGS5 HGS5S	●	2.78	0.109	3.0 3.0	3.07	1.10	1.889		7/64
MDW0280	HGS5 HGS5S	●	2.80	0.110	3.0	78	28	48		
MDW0290	HGS5 HGS5S	●	2.90	0.114	3.0	78	28	48		
MDW0300	HGS5 HGS5S	●	3.00	0.118	3.0 6.0	78	28	48		
MDW0310	HGS5 HGS5S	●	3.10	0.122	4.0 6.0	86	32	52		
MDW01250	HGS5 HGS5S	●	3.18	0.125	.125 6.0	3.07	1.10	1.889		1/8
MDW0320	HGS5 HGS5S	●	3.20	0.126	4.0 6.0	86	32	52		
MDW0330	HGS5 HGS5S	●	3.30	0.130	4.0 6.0	86	32	52		
MDW0340	HGS5 HGS5S	●	3.40	0.134	4.0 6.0	86	32	52		
MDW0350	HGS5 HGS5S	●	3.50	0.138	4.0 6.0	86	32	52		
MDW01406	HGS5 HGS5S	●	3.57	0.140	.156 6.0	3.39	1.42	1.890		
MDW0360	HGS5 HGS5S	●	3.60	0.142	4.0 6.0	86	36	48		
MDW0370	HGS5 HGS5S	●	3.70	0.146	4.0 6.0	86	36	48		
MDW0380	HGS5 HGS5S	●	3.80	0.150	4.0 6.0	86	36	48		
MDW0390	HGS5 HGS5S	●	3.90	0.154	4.0 6.0	86	36	48		
MDW01562	HGS5 HGS5S	●	3.97	0.156	.156 6.0	3.39	1.42	1.890		5/32
MDW0400	HGS5 HGS5S	●	4.00	0.158	4.0 6.0	86	36	48		
MDW01590	HGS5 HGS5S	●	4.04	0.159	.188 6.0	3.86	1.57	2.20		#21
MDW0410	HGS5 HGS5S	●	4.10	0.161	5.0 6.0	98	40	56		
MDW0420	HGS5 HGS5S	●	4.20	0.165	5.0 6.0	98	40	56		
MDW0430	HGS5 HGS5S	●	4.30	0.169	5.0 6.0	98	40	56		
MDW01719	HGS5 HGS5S	●	4.37	0.172	.188 6.0	3.86	1.57	2.20		11/64



MDW-HGS5 Series Solid Carbide Coolant Through Drills

SERIES MDW-HGS5

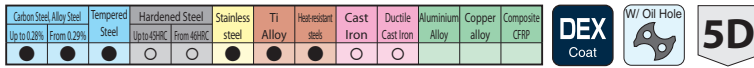

Items labeled in purple represent drills that fit in Shrink Fit Holders

Catalog Number (inch/metric)	Type	Stock	D _c mm	D _c Inch	Shank Diameter D _s (in/mm)	Overall Length L (in/mm)	Flute Length l ₁ (in/mm)	Shank Length l ₂ (in/mm)	Tap Size	Fractional Wire & Letters
MDW0440	HGS5 HGS5S	●	4.40	0.173	5.0 6.0	98.0	40	56		
MDW0450	HGS5 HGS5S	●	4.50	0.177	5.0 6.0	98.0	40	56		
MDW0460	HGS5 HGS5S	●	4.60	0.181	5.0 6.0	98.0	44	52		
MDW0470	HGS5 HGS5S	●	4.70	0.185	5.0 6.0	98.0	44	52		
MDW01875	HGS5 HGS5S	●	4.76	0.188	0.188 6.0	3.86	1.73	2.05		3/16
MDW0480	HGS5 HGS5S	●	4.80	0.189	5.0 6.0	98.0	44	52		
MDW0490	HGS5 HGS5S	●	4.90	0.193	5.0 6.0	98.0	44	52		
MDW0500	HGS5 HGS5S	●	5.00	0.196	5.0 6.0	98.0	44	52		
MDW0510	HGS5 HGS5S	●	5.10	0.201	6.0	100.0	44	54		
MDW02031	HGS5 HGS5S	●	5.16	0.203	0.234 6.0	3.937	1.73	2.13		13/64
MDW0520	HGS5 HGS5S	●	5.20	0.205	6.0	100.0	44	54		
MDW0530	HGS5 HGS5S	●	5.30	0.209	6.0	100.0	44	54		
MDW0540	HGS5 HGS5S	●	5.40	0.213	6.0	100.0	44	54		
MDW02130	HGS5 HGS5S	●	5.41	0.213	0.234 6.0	3.94	1.73	2.13		#3
MDW0550	HGS5 HGS5S	●	5.50	0.216	6.0	100.0	44	54		
MDW02188	HGS5 HGS5S	●	5.56	0.219	0.234 6.0	3.94	1.89	2.047		7/32
MDW0560	HGS5 HGS5S	●	5.60	0.221	6.0	100.0	48	52		
MDW02210	HGS5 HGS5S	●	5.61	0.221	0.234 6.0	3.94	1.89	2.047		#2
MDW0570	HGS5 HGS5S	●	5.70	0.224	6.0	100.0	48	52		
MDW0580	HGS5 HGS5S	●	5.80	0.228	6.0	100.0	48	52		
MDW0590	HGS5 HGS5S	●	5.90	0.232	6.0	100.0	48	52		
MDW02344	HGS5 HGS5S	●	5.995	0.234	0.234 6.0	3.94	1.89	2.047		15/64
MDW0600	HGS5 HGS5S	●	6.00	0.236	6.0	100.0	48	52		
MDW0610	HGS5 HGS5S	●	6.10	0.240	7.0 8.0	109.0	52	53		
MDW0620	HGS5 HGS5S	●	6.20	0.244	7.0 8.0	109.0	52	53		
MDW0630	HGS5 HGS5S	●	6.30	0.248	7.0 8.0	109.0	52	53		
MDW02500	HGS5 HGS5S	●	6.35	0.250	0.281 8.0	4.29	2.05	2.08		1/4
MDW0640	HGS5 HGS5S	●	6.40	0.252	7.0 8.0	109.0	52	53		
MDW0650	HGS5 HGS5S	●	6.50	0.256	7.0 8.0	109.0	52	53		
MDW02570	HGS5 HGS5S	●	6.53	0.257	0.281 8.0	4.29	2.20	2.087		#F
MDW0653	HGS5 HGS5S	●	6.53	0.257	7.0 8.0	109.0	56	53		
MDW0660	HGS5 HGS5S	●	6.60	0.260	7.0 8.0	109.0	56	53		
MDW0670	HGS5 HGS5S	●	6.70	0.264	7.0 8.0	109.0	56	53		
MDW02656	HGS5 HGS5S	●	6.75	0.266	0.281 8.0	4.29	2.20	2.087		17/64
MDW02660	HGS5 HGS5S	●	6.76	0.266	0.281 8.0	4.29	2.20	2.087		#H



Carbon Steel	Alloy Steel	Tempered Steel	Hardened Steel	Stainless Steel	Ti Alloy	Heat-resistant steel	Cast Iron	Ductile Cast Iron	Aluminum Alloy	Copper alloy	Composite CFRP
Up to 0.28%	From 0.29%		Up to 49RC	From 49RC							
●	●	●	○	○	●	●	○	○	○	○	○

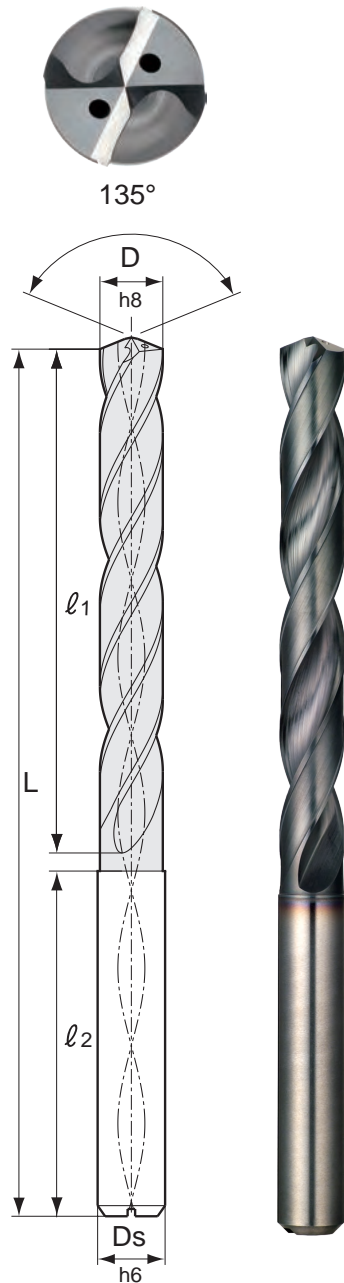

Items labeled in purple represent drills that fit in Shrink Fit Holders

Catalog Number (inch/metric)	Type	Stock	D _C mm	D _C Inch	Shank Diameter D _S (in/mm)	Overall Length L (in/mm)	Flute Length l ₁ (in/mm)	Shank Length l ₂ (in/mm)	Tap Size	Fractional Wire & Letters
MDW0680	HGS5	●	6.80	0.268	7.0	109.0	56	53		
MDW0690	HGS5	●	6.90	0.272	7.0	109.0	56	53		
MDW02720	HGS5	●	6.91	0.272	0.281	4.29	2.20	2.087		#I
MDW0700	HGS5	●	7.00	0.276	7.0	109.0	56	53		
MDW02770	HGS5	●	7.04	0.277	0.281	4.29	2.20	2.087		#J
MDW0710	HGS5	●	7.10	0.280	8.0	118.0	60	53		
MDW02812	HGS5	●	7.14	0.281	0.281	4.29	2.20	2.087		9/32
MDW0720	HGS5	●	7.20	0.284	8.0	118.0	60	54		
MDW0730	HGS5	●	7.30	0.287	8.0	118.0	60	54		
MDW0740	HGS5	●	7.40	0.291	8.0	118.0	60	54		
MDW0750	HGS5	●	7.50	0.295	8.0	118.0	60	54		
MDW02969	HGS5	●	7.54	0.297	0.313	4.64	2.52	2.126		19/64
MDW0760	HGS5	●	7.60	0.299	8.0	118.0	64	54		
MDW0770	HGS5	●	7.70	0.303	8.0	118.0	64	54		
MDW0780	HGS5	●	7.80	0.307	8.0	118.0	64	54		
MDW0790	HGS5	●	7.90	0.311	8.0	118.0	64	54		
MDW03125	HGS5	●	7.94	0.313	0.313	4.64	2.52	2.126		5/16
MDW0800	HGS5	●	8.00	0.315	8.0	118.0	64	54		
MDW0810	HGS5	●	8.10	0.319	9.0	127.0	68	55		
MDW0820	HGS5	●	8.20	0.323	9.0	127.0	68	55		
MDW03230	HGS5	●	8.204	0.323	0.359	5.0	2.68	2.165		#P
MDW0830	HGS5	●	8.30	0.327	9.0	127.0	68	55		
MDW03281	HGS5	●	8.33	0.328	0.359	5.0	2.68	2.165		21/64
MDW0840	HGS5	●	8.40	0.331	9.0	127.0	68	55		
MDW03320	HGS5	●	8.43	0.332	0.359	5.0	2.68	2.165		#Q
MDW0850	HGS5	●	8.50	0.335	9.0	127.0	68	55		
MDW0860	HGS5	●	8.60	0.339	9.0	127.0	72	55		
MDW0870	HGS5	●	8.70	0.343	9.0	127.0	72	55		
MDW03438	HGS5	●	8.73	0.344	0.359	5.00	2.83	2.165		11/32
MDW0880	HGS5	●	8.80	0.347	9.0	127.0	72	55		
MDW0890	HGS5	●	8.90	0.350	9.0	127.0	72	55		
MDW0900	HGS5	●	9.00	0.354	9.0	127.0	72	55		
MDW0910	HGS5	●	9.10	0.358	10.0	136.0	76	56		
MDW03594	HGS5	●	9.13	0.359	0.359	5.0	2.83	2.16		23/64

Solid Carbide Drills



MDW-HGS5 Series Solid Carbide Coolant Through Drills

SERIES MDW-HGS5

Carbon Steel Up to 0.28%	Alloy Steel From 0.29%	Tempered Steel	Hardened Steel Up to 45HRC	Stainless steel From 46HRC	Ti Alloy	Heat-resistant steel	Cast Iron	Ductile Cast Iron	Aluminium Alloy	Copper alloy	Composite CFRP	DEX Coat	W/Oil Hole	5D
-----------------------------	---------------------------	----------------	-------------------------------	-------------------------------	----------	----------------------	-----------	-------------------	-----------------	--------------	----------------	----------	------------	----

Items labeled in purple represent drills that fit in Shrink Fit Holders

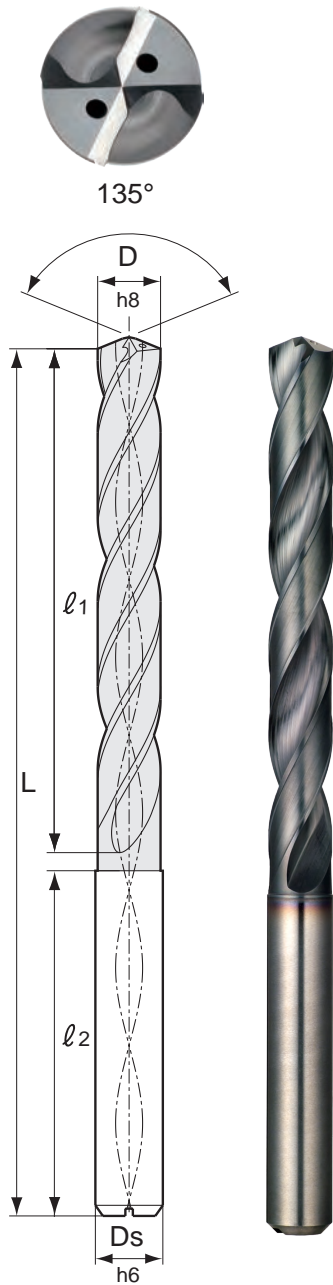

Catalog Number (inch/metric) Ex: MDW0900HGS5 or MDW0900HGS5S	Type	Stock	D _c mm	D _c Inch	Shank Diameter D _s (in/mm)	Overall Length L (in/mm)	Flute Length l ₁ (in/mm)	Shank Length l ₂ (in/mm)	Tap Size	Fractional Wire & Letters
MDW0920	HGS5 HGS5S	●	9.2	0.362	10.0	136	76	56		
MDW0930	HGS5 HGS5S	●	9.3	0.366	10.0	136	76	56		
MDW03680	HGS5 HGS5S	●	9.35	0.368	0.391 10.0	5.35	2.99	2.205		#U
MDW0940	HGS5 HGS5S	●	9.4	0.370	10.0	136	76	56		
MDW0950	HGS5 HGS5S	●	9.5	0.374	10.0	136	76	56		
MDW03750	HGS5 HGS5S	●	9.53	0.375	0.391 10.0	5.35	3.15	2.205		3/8
MDW0960	HGS5 HGS5S	●	9.6	0.378	10.0	136	80	56		
MDW0970	HGS5 HGS5S	●	9.7	0.382	10.0	136	80	56		
MDW0980	HGS5 HGS5S	●	9.8	0.386	10.0	136	80	56		
MDW0990	HGS5 HGS5S	●	9.9	0.390	10.0	136	80	56		
MDW03906	HGS5 HGS5S	●	9.92	0.391	0.391 10.0	5.35	3.14	2.205		25/64
MDW1000	HGS5 HGS5S	●	10.0	0.394	10.0	136	80	56		
MDW1010	HGS5 HGS5S	●	10.1	0.398	11.0 12.0	149	84	61		
MDW1020	HGS5 HGS5S	●	10.2	0.402	11.0 12.0	149	84	61		
MDW1030	HGS5 HGS5S	●	10.3	0.406	11.0 12.0	149	84	61		
MDW4062	HGS5 HGS5S	●	10.32	0.406	0.438 12.0	5.87	3.31	2.402		13/32
MDW1040	HGS5 HGS5S	●	10.4	0.409	11.0 12.0	149	84	61		
MDW1050	HGS5 HGS5S	●	10.5	0.413	11.0 12.0	149	84	61		
MDW1060	HGS5 HGS5S	●	10.6	0.417	11.0 12.0	149	88	61		
MDW1070	HGS5 HGS5S	●	10.7	0.421	11.0 12.0	149	88	61		
MDW04219	HGS5 HGS5S	●	10.72	0.422	0.438 12.0	5.87	3.47	2.402		27/64
MDW1080	HGS5 HGS5S	●	10.8	0.425	11.0 12.0	149	88	61		
MDW1090	HGS5 HGS5S	●	10.9	0.429	11.0 12.0	149	88	61		
MDW1100	HGS5 HGS5S	●	11.0	0.433	11.0 12.0	149	88	61		
MDW1110	HGS5 HGS5S	●	11.1	0.437	12.0	158	92	62		
MDW04375	HGS5 HGS5S	●	11.11	0.438	0.438 12.0	5.87	3.47	2.402		7/16
MDW1120	HGS5 HGS5S	●	11.2	0.441	12.0	158	92	62		
MDW1130	HGS5 HGS5S	●	11.3	0.445	12.0	158	92	62		
MDW1140	HGS5 HGS5S	●	11.4	0.449	12.0	158	92	62		
MDW1150	HGS5 HGS5S	●	11.5	0.453	12.0	158	92	62		
MDW04531	HGS5 HGS5S	●	11.51	0.453	0.469 12.0	6.22	3.78	2.441		29/64
MDW1160	HGS5 HGS5S	●	11.6	0.457	12.0	158	96	62		
MDW1170	HGS5 HGS5S	●	11.7	0.461	12.0	158	96	62		
MDW1180	HGS5 HGS5S	●	11.8	0.465	12.0	158	96	62		
MDW1190	HGS5 HGS5S	●	11.9	0.469	12.0	158	96	62		
MDW04688	HGS5 HGS5S	●	11.91	0.469	0.469 12.0	6.22	3.78	2.441		15/32



Items labeled in purple represent drills that fit in Shrink Fit Holders

Carbon Steel	Alloy Steel	Tempered Steel	Hardened Steel	Stainless Steel	Ti Alloy	Heat-resistant steel	Cast Iron	Ductile Cast Iron	Aluminum Alloy	Copper alloy	Composite CFRP	DEX Coat	Oil Hole	5D
Up to 0.28%	From 0.2%		Up to 45RC	From 45RC										



135°

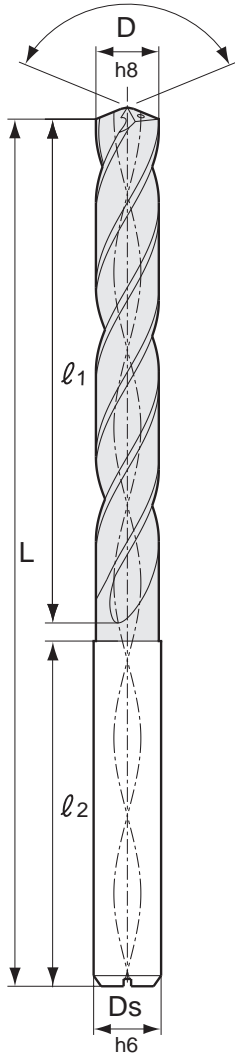

Solid Carbide Drills

Catalog Number (inch/metric)	Type	Stock	D _C mm	D _C Inch	Shank Diameter D _S (in/mm)	Overall Length L (in/mm)	Flute Length l ₁ (in/mm)	Shank Length l ₂ (in/mm)	Tap Size	Fractional Wire & Letters
MDW1200	HGS5 HGS5S	●	12.0	0.472	12.0	158	96	63		
MDW1210	HGS5 HGS5S	●	12.1	0.476	13.0 14.0	167	100	63		
MDW1220	HGS5 HGS5S	●	12.2	0.480	13.0 14.0	167	100	63		
MDW1230	HGS5 HGS5S	●	12.3	0.484	13.0 14.0	167	100	63		
MDW04844	HGS5 HGS5S	●	12.31	0.484	0.516 14.0	6.57	3.78	2.480		31/64
MDW1240	HGS5 HGS5S	●	12.4	0.488	13.0 14.0	167	100	63		
MDW1250	HGS5 HGS5S	●	12.5	0.492	13.0 14.0	167	100	63		
MDW1260	HGS5 HGS5S	●	12.6	0.496	13.0 14.0	167	104	63		
MDW1270	HGS5 HGS5S	●	12.7	0.500	13.0 14.0	167	104	63		1/2
MDW05000	HGS5 HGS5S	●	12.7	0.500	0.516 14.0	6.57	4.09	2.480		1/2
MDW1280	HGS5 HGS5S	●	12.8	0.504	13.0 14.0	167	104	63		
MDW1283	HGS5 HGS5S	●	12.83	0.505	13.0 14.0	167	104	63		
MDW1290	HGS5 HGS5S	●	12.9	0.508	13.0 14.0	167	104	63		
MDW1300	HGS5 HGS5S	●	13.0	0.512	13.0 14.0	167	104	63		
MDW05156	HGS5 HGS5S	●	13.09	0.516	0.516 14.0	6.57	4.09	2.480		33/64
MDW1310	HGS5 HGS5S	●	13.1	0.516	14.0	176	108	64		
MDW1320	HGS5 HGS5S	●	13.2	0.520	14.0	176	108	64		
MDW1330	HGS5 HGS5S	●	13.3	0.524	14.0	176	108	64		
MDW1340	HGS5 HGS5S	●	13.4	0.528	14.0	176	108	64		
MDW05312	HGS5 HGS5S	●	13.49	0.531	0.547 14.0	6.93	4.25	2.520		17/32
MDW1350	HGS5 HGS5S	●	13.5	0.532	14.0	176	108	64		
MDW1360	HGS5 HGS5S	●	13.6	0.535	14.0	176	112	64		
MDW1370	HGS5 HGS5S	●	13.7	0.539	14.0	176	112	64		
MDW1380	HGS5 HGS5S	●	13.8	0.543	14.0	176	112	64		
MDW05469	HGS5 HGS5S	●	13.89	0.547	0.547 14.0	6.93	4.41	2.520		35/64
MDW1390	HGS5 HGS5S	●	13.9	0.547	14.0	176	112	64		
MDW1400	HGS5 HGS5S	●	14.0	0.551	14.0	176	112	64		
MDW1410	HGS5 HGS5S	●	14.1	0.555	15.0 16.0	185	116	65		
MDW1420	HGS5 HGS5S	●	14.2	0.559	15.0 16.0	185	116	65		
MDW05625	HGS5 HGS5S	●	14.29	0.563	0.594 16.0	7.28	4.57	2.559		9/16
MDW1430	HGS5 HGS5S	●	14.3	0.563	15.0 16.0	185	116	65		
MDW1440	HGS5 HGS5S	●	14.4	0.567	15.0 16.0	185	116	65		
MDW1450	HGS5 HGS5S	●	14.5	0.571	15.0 16.0	185	116	65		
MDW1460	HGS5 HGS5S	●	14.6	0.575	15.0 16.0	185	120	65		
MDW05781	HGS5 HGS5S	●	14.68	0.578	0.594 16.0	7.28	4.72	2.55	5/8-18	37/64
MDW1470	HGS5 HGS5S	●	14.7	0.579	15.0 16.0	185	120	65		



MDW-HGS5 Series Solid Carbide Coolant Through Drills

SERIES MDW-HGS5

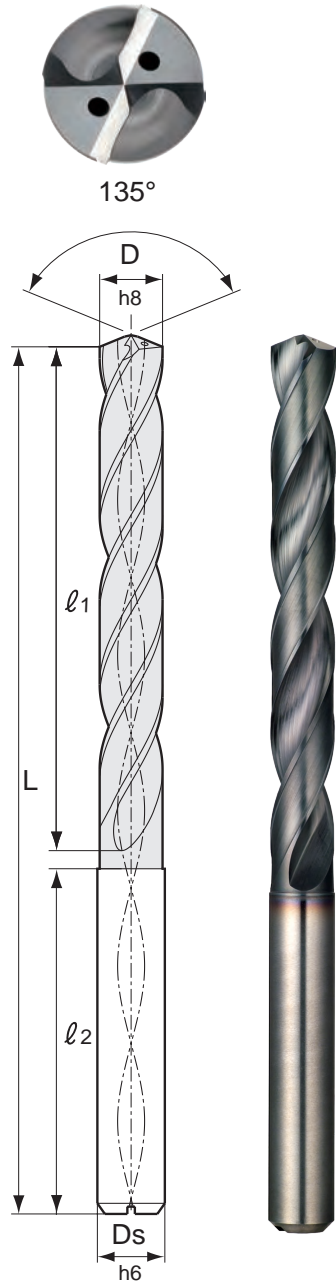

Items labeled in purple represent drills that fit in Shrink Fit Holders

Catalog Number (inch/metric)	Type	Stock	D _c mm	D _c Inch	Shank Diameter D _s (in/mm)	Overall Length L (in/mm)	Flute Length l ₁ (in/mm)	Shank Length l ₂ (in/mm)	Tap Size	Fractional Wire & Letters
MDW1480	HGS5 HGS5S	●	14.8	0.583	15.0 16.0	185	120	65		
MDW1490	HGS5 HGS5S	●	14.9	0.587	15.0 16.0	185	120	65		
MDW1500	HGS5 HGS5S	●	15.0	0.591	15.0 16.0	185	120	65		
MDW05937	HGS5 HGS5S	●	15.08	0.594	0.594 16.0	7.28	4.72	2.559		19/32
MDW1510	HGS5 HGS5S	●	15.1	0.595	16.0	194	124	66		
MDW1520	HGS5 HGS5S	●	15.2	0.598	16.0	194	124	66		
MDW1530	HGS5 HGS5S	●	15.3	0.602	16.0	194	124	66		
MDW1540	HGS5 HGS5S	●	15.4	0.606	16.0	194	124	66		
MDW06094	HGS5 HGS5S	●	15.48	0.609	0.625 16.0	7.64	4.88	2.598	11/16-12	39/64
MDW1550	HGS5 HGS5S	●	15.5	0.610	16.0	194	124	66	M18X2.5	
MDW1560	HGS5 HGS5S	●	15.6	0.614	16.0	194	128	66		
MDW1570	HGS5 HGS5S	●	15.7	0.618	16.0	194	128	66		
MDW1580	HGS5 HGS5S	●	15.8	0.622	16.0	194	128	66		
MDW06250	HGS5 HGS5S	●	15.88	0.625	0.625 16.0	7.64	5.04	2.598	11/16-16	5/8
MDW1590	HGS5 HGS5S	●	15.9	0.626	16.0	194	128	66		
MDW1600	HGS5 HGS5S	●	16.0	0.630	16.0	194	128	66		
MDW06406	HGS5 HGS5S	●	16.27	0.641	0.669	7.992	5.197	66		41/64
MDW1650	HGS5 HGS5S	★	16.5	0.650	17.0	203	132	67		
MDW06562	HGS5 HGS5S	●	16.67	0.656	0.669	7.992	5.354	67	3/4-10	21/32
MDW1700	HGS5 HGS5S	★	17.0	0.669	17.0	203	136	67		
MDW06875	HGS5 HGS5S	●	17.46	0.709	0.709	8.425	5.512	67	3/4-16	11/16
MDW1750	HGS5 HGS5S	★	17.5	0.689	17.0	214	140	74		
MDW1800	HGS5 HGS5S	★	18.0	0.709	18.0	214	144	70		
MDW1850	HGS5 HGS5S	★	18.5	0.728	18.0	221	148	73		
MDW1900	HGS5 HGS5S	★	19.0	0.748	19.0	221	152	69		
MDW1950	HGS5 HGS5S	★	19.5	0.768	19.0	230	156	74		
MDW2000	HGS5 HGS5S	★	20.0	0.787	20.0	230	160	70		

Solid Carbide Drills





h8 Manufacturing Tolerances

Tolerances of Diameters (in.)		Tolerances of Diameters (in.)		Tolerances of Diameters (in.)	
$D \leq .118$	+0 -0.00055	$.236 < D \leq .394$	+0 -0.00087	$.709 < D \leq .768$	+0 -0.0130
$.118 < D \leq .236$	+0 -0.00071	$.394 < D \leq .709$	+0 -0.0106		

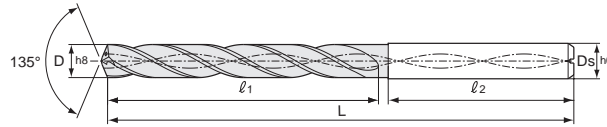

MDW-HGS8 8XD drill for excellent chip management and long tool life (Internal coolant)

Catalog Number (inch/metric)	Stock	Fractional Wire & Letters	Diameter D (in)	Diameter D (mm)	Overall Length L (in/mm)	Flute Length ℓ_1 (in/mm)	Shank Length ℓ_2 (in/mm)	Shank Diameter D_s (in/mm)	Tap Size
MDW0150HGS8	●		0.0591	1.50	70.0	18.5		3.00	
MDW0200HGS8	●		0.0787	2.00	76.00	24.00	50.00	3.00	
MDW0210HGS8			0.0827	2.10	81.00	27.50	52.00	3.00	3-56
MDW0220HGS8			0.0866	2.20	81.00	27.50	52.00	3.00	
MDW0230HGS8			0.0906	2.30	81.00	27.50	52.00	3.00	
MDW00937HGS8	●	3/32	0.0937	2.38	3.1890	1.0827	2.0472	0.1250	
MDW0240HGS8			0.0945	2.40	81.00	27.50	52.00	3.00	
MDW0250HGS8	●		0.0984	2.50	81.00	27.50	52.00	3.00	
MDW0260HGS8			0.1024	2.60	81.00	33.00	48.00	3.00	
MDW0270HGS8			0.1063	2.70	81.00	33.00	48.00	3.00	6-32
MDW0280HGS8			0.1102	2.80	81.00	33.00	48.00	3.00	
MDW0290HGS8			0.1142	2.90	81.00	33.00	48.00	3.00	3.5x6
MDW0300HGS8	●		0.1181	3.00	81.00	33.00	48.00	3.00	
MDW0310HGS8			0.1220	3.10	92.00	38.50	52.00	4.00	
MDW01250HGS8	●	1/8	0.1250	3.18	3.1890	1.2992	1.8898	0.1250	
MDW0320HGS8			0.1260	3.20	92.00	38.50	52.00	4.00	
MDW0330HGS8	●		0.1299	3.30	92.00	38.50	52.00	4.00	M4x.7
MDW0340HGS8			0.1339	3.40	92.00	38.50	52.00	4.00	
MDW0350HGS8	●		0.1378	3.50	92.00	38.50	52.00	4.00	
MDW01406HGS8	●		0.1406	3.57	3.6220	1.7323	1.8898	0.1562	
MDW0360HGS8			0.1417	3.60	92.00	44.00	48.00	4.00	
MDW0370HGS8			0.1457	3.70	92.00	44.00	48.00	4.00	M4.5x.7
MDW0380HGS8	●		0.1496	3.80	92.00	44.00	48.00	4.00	
MDW0390HGS8			0.1535	3.90	92.00	44.00	48.00	4.00	
MDW01562HGS8	●	5/32	0.1562	3.97	3.6220	1.7323	1.8898	0.1562	
MDW0400HGS8	●		0.1575	4.00	92.00	44.00	48.00	4.0	
MDW01590HGS8	●	#21	0.1590	4.04	4.1339	1.9488	2.1260	0.1875	10-32
MDW0410HGS8			0.1614	4.10	105.00	49.50	54.00	5.00	
MDW0420HGS8	●		0.1654	4.20	105.00	49.50	54.00	5.00	M5x.8
MDW0430HGS8			0.1693	4.30	105.00	49.50	54.00	5.00	
MDW01719HGS8	●	11/64	0.1719	4.37	4.1339	1.9488	2.1260	0.1875	
MDW0440HGS8			0.1732	4.40	105.00	49.50	54.00	5.00	
MDW0450HGS8	●		0.1772	4.50	105.00	49.50	54.00	5.00	
MDW0460HGS8			0.1811	4.60	105.00	55.00	50.00	5.00	
MDW0470HGS8			0.1850	4.70	105.00	55.00	50.00	5.00	
MDW01875HGS8	●	3/16	0.1875	4.76	4.1339	2.1654	1.9685	0.1875	
MDW0480HGS8			0.1890	4.80	105.00	55.00	50.00	5.00	
MDW0490HGS8			0.1929	4.90	105.00	55.00	50.00	5.00	
MDW0500HGS8	●		0.1969	5.00	105.00	55.00	50.00	5.00	M6x1
MDW0510HGS8	★		0.2008	5.10	118.00	60.50	56.00	6.00	
MDW02010HGS8	●	#7	0.2010	5.11	4.6457	2.3819	2.2047	0.2344	1/4-20
MDW02031HGS8	●	13/64	0.2031	5.16	4.6457	2.3819	2.2047	0.2344	
MDW0520HGS8			0.2047	5.20	118.00	60.50	56.00	6.00	
MDW0530HGS8			0.2087	5.30	118.00	60.50	56.00	6.00	
MDW0540HGS8			0.2126	5.40	118.00	60.50	56.00	6.00	
MDW02130HGS8	●	#3	0.2130	5.41	4.6457	2.3819	2.2047	0.2344	
MDW0550HGS8	●		0.2165	5.50	118.00	60.50	56.00	6.00	
MDW02188HGS8	●	7/32	0.2188	5.56	4.6457	2.5984	2.0472	0.2344	1/4-28
MDW0560HGS8	●		0.2205	5.60	118.00	66.00	52.00	6.00	

●=USA stocked item ★=Worldwide Warehouse item available in 10 business days
Some drills can achieve greater depths. Always check for sufficient flute length. Note: Special diameters available upon request. (continued on next page)



MDW-HGS8 Series Solid Carbide Coolant Through Drills

SERIES MDW-HGS8

Carbon Steel Alloy Steel Up to 0.28% C From 0.29%	Tempered Steel	Hardened Steel Up to 49RC From 48RC	Stainless steel	Ti Alloy	Heat-resistant steels	Cast Iron	Ductile Cast Iron	Aluminium Alloy	Copper alloy	Composite CFRP	DEX Coat	W/Oil Hole	8D
--	----------------	--	-----------------	----------	-----------------------	-----------	-------------------	-----------------	--------------	----------------	----------	------------	----

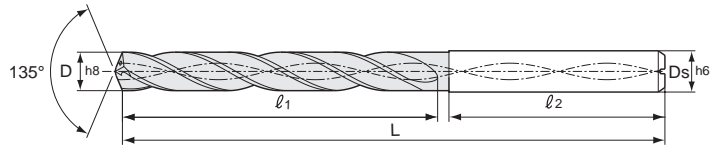

(continued from previous page)

MDW-HGS8 8XD drill for excellent chip management and long tool life (Internal coolant)

Catalog Number (inch/metric)	Stock	Fractional Wire & Letters	Diameter D (in)	Diameter D (mm)	Overall Length L (in/mm)	Flute Length l_1 (in/mm)	Shank Length l_2 (in/mm)	Shank Diameter D_s (in/mm)	Tap Size
MDW02210HGS8	●	#2	0.2210	5.61	4.6457	2.5984	2.0472	0.2344	
MDW0570HGS8			0.2244	5.70	118.00	66.00	52.00	6.0	
MDW0580HGS8			0.2283	5.80	118.00	66.00	52.00	6.0	
MDW0590HGS8			0.2323	5.90	118.00	66.00	52.00	6.0	
MDW02344HGS8	●	15/64	0.2344	5.95	4.6457	2.5984	2.0472	0.2344	
MDW0600HGS8	●		0.2362	6.00	118.00	66.00	52.00	6.00	M7x1
MDW0610HGS8			0.2402	6.10	130.00	71.50	53.00	7.00	
MDW0620HGS8			0.2441	6.20	130.00	71.50	53.00	7.00	
MDW0630HGS8			0.2480	6.30	130.00	71.50	53.00	7.00	
MDW02500HGS8	●	1/4	0.2500	6.35	5.1181	2.8150	2.0866	0.2812	
MDW0640HGS8			0.2520	6.40	130.00	71.50	53.00	7.00	
MDW0650HGS8	●		0.2559	6.50	130.00	71.50	53.00	7.00	
MDW02570HGS8	●	#F	0.2570	6.53	5.1181	3.0315	2.0866	0.2812	5/16-18
MDW0653HGS8			0.2571	6.53	130.00	77.00	53.00	7.00	
MDW0660HGS8			0.2598	6.60	130.00	77.00	53.00	7.00	
MDW0670HGS8			0.2638	6.70	130.00	77.00	53.00	7.00	
MDW02656HGS8	●	17/64	0.2656	6.75	5.1181	3.0315	2.0866	0.2812	
MDW02660HGS8	●	#H	0.2660	6.76	5.1181	3.0315	2.0866	0.2812	
MDW0680HGS8	●		0.2677	6.80	130.00	77.00	53.00	7.00	
MDW0690HGS8			0.2717	6.90	130.00	77.00	53.00	7.00	
MDW02720HGS8	●	#I	0.2720	6.91	5.1181	3.0315	2.0866	0.2812	5/16-24
MDW0700HGS8	●		0.2756	7.00	130.00	77.00	53.00	7.00	
MDW02770HGS8	●	#J	0.2770	7.04	5.1181	3.0315	2.0866	0.2812	
MDW0710HGS8			0.2795	7.10	142.00	82.50	54.00	8.00	
MDW02812HGS8	●	9/32	0.2812	7.14	5.1181	3.0315	2.0866	0.2812	
MDW0720HGS8			0.2835	7.20	142.00	82.50	54.00	8.00	
MDW0730HGS8			0.2874	7.30	142.00	82.50	54.00	8.00	
MDW0740HGS8			0.2913	7.40	142.00	82.50	54.00	8.00	
MDW0750HGS8	●		0.2953	7.50	142.00	82.50	54.00	8.00	
MDW02969HGS8	●	19/64	0.2969	7.54	5.5906	3.4646	2.1260	0.3125	
MDW0760HGS8			0.2992	7.60	142.00	88.00	54.00	8.00	
MDW0770HGS8			0.3031	7.70	142.00	88.00	54.00	8.00	
MDW0780HGS8			0.3071	7.80	142.00	88.00	54.00	8.00	M9x1.25
MDW0790HGS8			0.3110	7.90	142.00	88.00	54.00	8.00	
MDW03125HGS8	●	5/16	0.3125	7.94	5.5906	3.4646	2.1260	0.3125	3/8-16
MDW0800HGS8	●		0.3150	8.00	142.00	88.00	54.00	8.00	
MDW0810HGS8			0.3189	8.10	154.00	93.50	55.00	9.00	
MDW0820HGS8	★		0.3228	8.20	154.00	93.50	55.00	9.00	
MDW03230HGS8	●	#P	0.3230	8.20	6.0630	3.6811	2.1654	0.3594	
MDW0830HGS8			0.3268	8.30	154.00	93.50	55.00	9.00	
MDW03281HGS8	●	21/64	0.3281	8.33	6.0630	3.6811	2.1654	0.3594	
MDW0840HGS8			0.3307	8.40	154.00	93.50	55.00	9.00	
MDW03320HGS8	●	#Q	0.3320	8.43	6.0630	3.6811	2.1654	0.3594	
MDW0850HGS8	●		0.3346	8.50	154.00	93.50	55.00	9.00	M10x1.5
MDW0860HGS8			0.3386	8.60	154.00	99.00	55.00	9.00	
MDW0870HGS8			0.3425	8.70	154.00	99.00	55.00	9.00	
MDW03438HGS8	●	11/32	0.3438	8.73	6.0630	3.8976	2.1654	0.3594	

●=USA stocked item ★=Worldwide Warehouse item available in 10 business days
Some drills can achieve greater depths. Always check for sufficient flute length. Note: Special diameters available upon request.



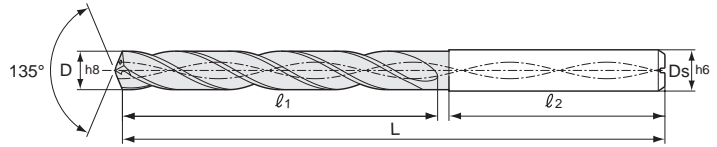

(continued from previous page)

MDW-HGS8 8XD drill for excellent chip management and long tool life (Internal coolant)

Catalog Number (inch/metric)	Stock	Fractional Wire & Letters	Diameter D (in)	Diameter D (mm)	Overall Length L (in/mm)	Flute Length l_1 (in/mm)	Shank Length l_2 (in/mm)	Shank Diameter D_s (in/mm)	Tap Size
MDW0880HGS8			0.3465	8.80	154.00	99.00	55.00	9.00	
MDW0890HGS8			0.3504	8.90	154.00	99.00	55.00	9.00	
MDW0900HGS8	●		0.3543	9.00	154.00	99.00	55.00	9.00	
MDW0910HGS8			0.3583	9.10	166.00	104.50	56.00	10.00	
MDW03594HGS8	●	23/64	0.3594	9.13	6.0630	3.8976	2.1654	0.3594	
MDW0920HGS8			0.3622	9.20	166.00	104.50	56.00	10.00	
MDW0930HGS8			0.3661	9.30	166.00	104.50	56.00	10.00	
MDW03680HGS8	●	#U	0.3680	9.35	6.5354	4.1142	2.2047	0.3906	7/16-14
MDW0940HGS8			0.3701	9.40	166.00	104.50	56.00	10.00	
MDW0950HGS8	●		0.3740	9.50	166.00	104.50	56.00	10.00	
MDW03750HGS8	●	3/8	0.3750	9.53	6.5354	4.3307	2.2047	0.3906	
MDW0960HGS8	●		0.3780	9.60	166.00	110.00	56.00	10.00	
MDW0970HGS8			0.3819	9.70	166.00	110.00	56.00	10.00	
MDW0980HGS8			0.3858	9.80	166.00	110.00	56.00	10.00	
MDW0990HGS8			0.3898	9.90	166.00	110.00	56.00	10.00	
MDW03906HGS8	●	25/64	0.3906	9.92	6.5354	4.3307	2.2047	0.3906	
MDW1000HGS8	●		0.3937	10.00	166.00	110.00	56.00	10.00	
MDW1010HGS8			0.3976	10.10	182.00	115.50	61.00	11.00	
MDW1020HGS8			0.4016	10.20	182.00	115.50	61.00	11.00	M12x1.75
MDW1030HGS8	●		0.4055	10.30	182.00	115.50	61.00	11.00	
MDW04062HGS8	●	13/32	0.4062	10.32	7.1654	4.5472	2.4016	0.4375	
MDW1040HGS8			0.4094	10.40	182.00	115.50	61.00	11.00	
MDW1050HGS8	●		0.4134	10.50	182.00	115.50	61.00	11.00	
MDW1060HGS8			0.4173	10.60	182.00	121.00	61.00	11.00	
MDW1070HGS8			0.4213	10.70	182.00	121.00	61.00	11.00	
MDW04219HGS8	●	27/64	0.4219	10.72	7.1654	4.7638	2.4016	0.4375	1/2-13
MDW1080HGS8			0.4252	10.80	182.00	121.00	61.00	11.00	
MDW1090HGS8			0.4291	10.90	182.00	121.00	61.00	11.00	
MDW1100HGS8	●		0.4331	11.00	182.00	121.00	61.00	11.00	
MDW1110HGS8			0.4370	11.10	194.00	126.50	62.00	12.00	
MDW04375HGS8	●	7/16	0.4375	11.11	7.1654	4.7638	2.4016	0.4375	
MDW1120HGS8			0.4409	11.20	194.00	126.50	62.00	12.00	
MDW1130HGS8			0.4449	11.30	194.00	126.50	62.00	12.00	
MDW1140HGS8			0.4488	11.40	194.00	126.50	62.00	12.00	
MDW1150HGS8	●		0.4528	11.50	194.00	126.50	62.00	12.00	
MDW04531HGS8	●	29/64	0.4531	11.51	7.6378	5.1969	2.4409	0.4688	1/2-20
MDW1160HGS8			0.4567	11.60	194.00	132.00	62.00	12.00	
MDW1170HGS8			0.4606	11.70	194.00	132.00	62.00	12.00	
MDW1180HGS8			0.4646	11.80	194.00	132.00	62.00	12.00	
MDW1190HGS8			0.4685	11.90	194.00	132.00	62.00	12.00	
MDW04688HGS8	●	15/32	0.4688	11.91	7.6378	5.1969	2.4409	0.4688	
MDW1200HGS8	●		0.4724	12.00	194.00	132.00	62.00	12.00	M14x2
MDW1210HGS8			0.4764	12.10	206.00	137.50	63.00	13.00	
MDW1220HGS8			0.4803	12.20	206.00	137.50	63.00	13.00	
MDW1230HGS8			0.4843	12.30	206.00	137.50	63.00	13.00	9/16-12
MDW04844HGS8	●	31/64	0.4844	12.30	8.1102	5.4134	2.4803	0.5156	
MDW1240HGS8			0.4882	12.40	206.00	137.50	63.00	13.00	

● = USA stocked item ★ = Worldwide Warehouse item available in 10 business days
 Some drills can achieve greater depths. Always check for sufficient flute length. Note: Special diameters available upon request.



MDW-HGS8 Series Solid Carbide Coolant Through Drills

SERIES MDW-HGS8

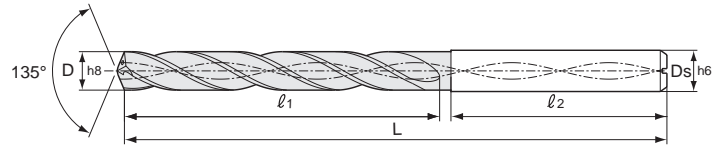
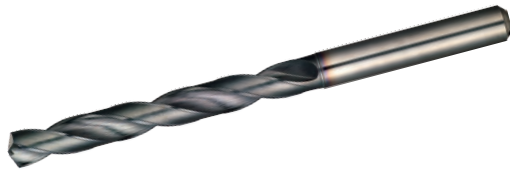
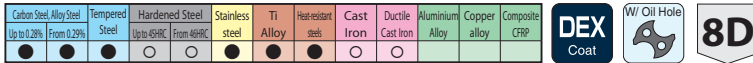

(continued from previous page)

MDW-HGS8 8XD drill for excellent chip management and long tool life (Internal coolant)

Catalog Number (inch/metric)	Stock	Fractional Wire & Letters	Diameter D (in)	Diameter D (mm)	Overall Length L (in/mm)	Flute Length l_1 (in/mm)	Shank Length l_2 (in/mm)	Shank Diameter D_s (in/mm)	Tap Size
MDW1250HGS8	●		0.4921	12.50	206.00	137.50	63.00	13.00	
MDW1260HGS8			0.4961	12.60	206.00	143.00	63.00	13.00	
MDW1270HGS8		1/2	0.5000	12.70	206.00	143.00	63.00	13.00	
MDW05000HGS8	●	1/2	0.5000	12.70	8.1102	5.6299	2.4803	0.5156	
MDW1280HGS8			0.5039	12.80	206.00	143.00	63.00	13.00	
MDW1283HGS8			0.5051	12.83	206.00	143.00	63.00	13.00	
MDW1290HGS8			0.5079	12.90	206.00	143.00	63.00	13.00	
MDW1300HGS8	●		0.5118	13.00	206.00	143.00	63.00	13.00	
MDW05156HGS8	●	33/64	0.5156	13.10	8.1102	5.6299	2.4803	0.5156	9/19-18
MDW1310HGS8			0.5157	13.10	218.00	148.50	64.00	14.00	
MDW1320HGS8			0.5197	13.20	218.00	148.50	64.00	14.00	
MDW1330HGS8			0.5236	13.30	218.00	148.50	64.00	14.00	
MDW1340HGS8			0.5276	13.40	218.00	148.50	64.00	14.00	
MDW05312HGS8	●	17/32	0.5312	13.49	8.5827	5.8465	2.5197	0.5469	5/8-11
MDW1350HGS8	●		0.5315	13.50	218.00	148.50	64.00	14.00	
MDW1360HGS8			0.5354	13.60	218.00	154.00	64.00	14.00	
MDW1370HGS8			0.5394	13.70	218.00	154.00	64.00	14.00	
MDW1380HGS8			0.5433	13.80	218.00	154.00	64.00	14.00	
MDW05469HGS8	●	35/64	0.5469	13.89	8.5827	6.0630	2.5197	0.5469	M16x2
MDW1390HGS8			0.5472	13.90	218.00	154.00	64.00	14.00	
MDW1400HGS8	●		0.5512	14.00	218.00	154.00	64.00	14.00	
MDW1410HGS8			0.5551	14.10	230.00	159.50	65.00	15.00	
MDW1420HGS8			0.5591	14.20	230.00	159.50	65.00	15.00	
MDW05625HGS8	●	9/16	0.5625	14.29	9.0551	6.2795	2.5591	0.5937	
MDW1430HGS8			0.5630	14.30	230.00	159.50	65.00	15.00	
MDW1440HGS8			0.5669	14.40	230.00	159.50	65.00	15.00	
MDW1450HGS8	●		0.5709	14.50	230.00	159.50	65.00	15.00	
MDW1460HGS8			0.5748	14.60	230.00	165.00	65.00	15.00	
MDW05781HGS8	●	37/64	0.5781	14.68	9.0551	6.4961	2.5591	0.5937	5/8-18
MDW1470HGS8			0.5787	14.70	230.00	165.00	65.00	15.00	
MDW1480HGS8			0.5827	14.80	230.00	165.00	65.00	15.00	
MDW1490HGS8			0.5866	14.90	230.00	165.00	65.00	15.00	
MDW1500HGS8	●		0.5906	15.00	230.00	165.00	65.00	15.00	
MDW05937HGS8	●	19/32	0.5937	15.08	9.0551	6.4961	2.5591	0.5937	
MDW1510HGS8			0.5945	15.10	242.00	170.50	66.00	16.00	
MDW1520HGS8			0.5984	15.20	242.00	170.50	66.00	16.00	
MDW1530HGS8			0.6024	15.30	242.00	170.50	66.00	16.00	
MDW1540HGS8			0.6063	15.40	242.00	170.50	66.00	16.00	
MDW06094HGS8	●	39/64	0.6094	15.48	9.5276	6.7126	2.5984	0.6250	11/16-12
MDW1550HGS8	●		0.6102	15.50	242.00	170.50	66.00	16.00	M18x2.5
MDW1560HGS8			0.6142	15.60	242.00	176.00	66.00	16.00	
MDW1570HGS8			0.6181	15.70	242.00	176.00	66.00	16.00	
MDW1580HGS8			0.6220	15.80	242.00	176.00	66.00	16.00	
MDW06250HGS8	●	5/8	0.6250	15.88	9.5276	6.9291	2.5984	0.6250	11/16-16
MDW1590HGS8			0.6260	15.90	242.00	176.00	66.00	16.00	
MDW1600HGS8	●		0.6299	16.00	242.00	176.00	66.00	16.00	

● = USA stocked item ★ = Worldwide Warehouse item available in 10 business days

Some drills can achieve greater depths. Always check for sufficient flute length. Note: Special diameters available upon request.



Recommended Parameters for MDW GS Series

Recommended Speeds & Feeds

Solid Carbide Drills

MDW		Work Material	Hardness HB	Speed = SFM Feed = IPR	Drill Diameter (inch)			
					$\phi < - \phi 0.196$	$\phi 0.197 - \phi 0.394$	$\phi 0.395 - \phi 0.630$	
GS 2D 4D	P	Low Carbon Steel	<190	SFM	110 - 250	160 - 275	210 - 360	
				IPR	.004 - .008	.006 - .010	.008 - .012	
			190 ~ 250	SFM	110 - 250	160 - 275	210 - 360	
				IPR	.004 - .008	.006 - .010	.008 - .012	
			250 ~ 300	SFM	100 - 225	140 - 250	190 - 325	
				IPR	.003 - .006	.004 - .008	.006 - .010	
		Medium Carbon Steel	180 ~ 275	SFM	110 - 250	160 - 275	210 - 360	
				IPR	.004 - .008	.006 - .010	.008 - .012	
			275 ~ 350	SFM	100 - 225	140 - 250	190 - 325	
				IPR	.003 - .006	.004 - .008	.006 - .010	
			Alloy Steel	200	SFM	110 - 250	160 - 275	210 - 360
					IPR	.004 - .008	.006 - .010	.008 - .012
	350	SFM		80 - 210	115 - 220	115 - 250		
		IPR		.003 - .006	.004 - .008	.006 - .010		
	M	300 Austenitic Stainless Steel	SFM	50 - 115	60 - 160	80 - 210		
			IPR	.002 - .006	.003 - .008	.004 - .010		
		400 Martensitic Stainless Steel	SFM	60 - 120	75 - 180	90 - 225		
			IPR	.002 - .006	.003 - .008	.006 - .010		
	K	Cast Iron	SFM	115 - 300	195 - 390	250 - 415		
			IPR	.006 - .010	.006 - .014	.006 - .014		
		Ductile Iron	SFM	115 - 185	160 - 300	210 - 375		
			IPR	.006 - .010	.006 - .014	.006 - .014		
	H	Hardened Steel	45-60 Rc	SFM	40 - 60	40 - 80	50 - 100	
			IPR	.002 - .004	.003 - .006	.004 - .008		
S	Titanium Alloy Ti-6Al-4V	SFM	40 - 80	40 - 100	50 - 110			
		IPR	.003 - .004	.003 - .005	.003 - .006			
	Exotics - Inconel, Monel	SFM	30 - 60	30 - 60	40 - 80			
		IPR	.002 - .003	.003 - .005	.003 - .006			
N	Aluminum alloy	SFM	300 - 700	400 - 800	400 - 800			
		IPR	.003 - .006	.004 - .008	.006 - .012			
	Copper Alloy	SFM	300 - 700	400 - 800	400 - 800			
		IPR	.003 - .006	.004 - .008	.006 - .010			



MDW		Work Material	Hardness HB	Speed = SFM Feed = IPR	Drill Diameter (inch)			
					$\phi < \phi 0.196$	$\phi 0.197 - \phi 0.394$	$\phi 0.395 - \phi 0.630$	
HGS 3D 5D 8D	P	Low Carbon Steel	<190	SFM	300 - 475	400 - 550	450 - 650	
				IPR	.004 - .008	.006 - .010	.008 - .014	
			190 ~ 250	SFM	225 - 425	265 - 530	425 - 625	
				IPR	.004 - .008	.006 - .010	.008 - .014	
			250 ~ 300	SFM	175 - 375	225 - 495	250 - 525	
				IPR	.003 - .006	.004 - .008	.006 - .012	
		Medium Carbon Steel	180 ~ 275	SFM	225 - 425	265 - 530	350 - 575	
				IPR	.004 - .008	.006 - .010	.008 - .014	
			275 ~ 350	SFM	175 - 375	225 - 495	305 - 525	
				IPR	.003 - .006	.004 - .008	.006 - .012	
			Alloy Steel	200	SFM	190 - 380	225 - 475	275 - 525
					IPR	.003 - .008	.006 - .010	.008 - .014
	350	SFM		125 - 300	155 - 325	155 - 350		
		IPR		.003 - .006	.004 - .008	.006 - .010		
	M	300 Austenitic Stainless Steel	160 ~ 280	SFM	120 - 225	150 - 325	150 - 325	
				IPR	.002 - .006	.004 - .010	.006 - .012	
		400 Martensitic Stainless Steel	160 ~ 240	SFM	120 - 250	175 - 350	175 - 350	
				IPR	.002 - .006	.004 - .010	.006 - .012	
	K	Cast Iron		SFM	150 - 380	250 - 475	275 - 530	
				IPR	.006 - .010	.006 - .014	.006 - .014	
		Ductile Iron		SFM	150 - 350	225 - 450	250 - 500	
				IPR	.006 - .010	.006 - .014	.006 - .014	
	H	Hardened Steel	45-60 Rc	SFM	60 - 190	80 - 225	80 - 225	
				IPR	.002 - .004	.003 - .006	.004 - .008	
S	Titanium Alloy Ti-6Al-4V		SFM	65 - 130	80 - 130	80 - 160		
			IPR	.003 - .004	.003 - .005	.003 - .006		
	Exotics - Inconel, Monel		SFM	40 - 85	40 - 100	50 - 120		
			IPR	.002 - .003	.003 - .005	.003 - .006		
N	Aluminum alloy		SFM	500 - 800	600 - 1000	600 - 1000		
			IPR	.003 - .006	.004 - .008	.006 - .012		
	Copper Alloy		SFM	400 - 800	500 - 800	500 - 800		
			IPR	.003 - .006	.004 - .008	.006 - .010		

Solid Carbide Drills



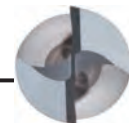

General Features

The flat multidrill MDF type is a solid carbide drill that can be used for various purposes including high-efficiency spot facing and drilling on inclined surfaces and curved surfaces.



Characteristics and Applications

- **Applicable to various types of drilling thanks to a point angle of 180°.**
Applicable to high-efficiency spot facing, drilling in non-horizontal surfaces such as inclined and cylindrical surfaces, and interrupted drilling. Also reduces burrs at the hole exit.
- **Improves machining stability**
Achieves high rigidity by employing RS THINNING, which ensures thick web at the bottom.
- **Excellent chip evacuation**
Achieves excellent chip evacuation thanks to the wide chip pocket and a high-quality rake face shape.
- **Excellent cutting edge strength**
Achieves excellent cutting edge strength through optimized cutting edge design.



Reduction of Burrs at Hole Exit

Burrs at Hole Exit

Reduces exit burrs by half compared with general-purpose drills

Burr height : 0.18mm

Flat MULTIDRILL MDF Type

Burr height : 0.44mm

Conv. general-purpose drill

Work Material : SCM415
Tool : MDF0500S2D (ø5.0mm 2D)
Cutting Conditions : $v_c=215$ SFM $f=0.005$ IPR,
 $H=0.394''$, 150 Units, Wet
Equipment : Vertical Machining Center
M/C (BT40)

Application

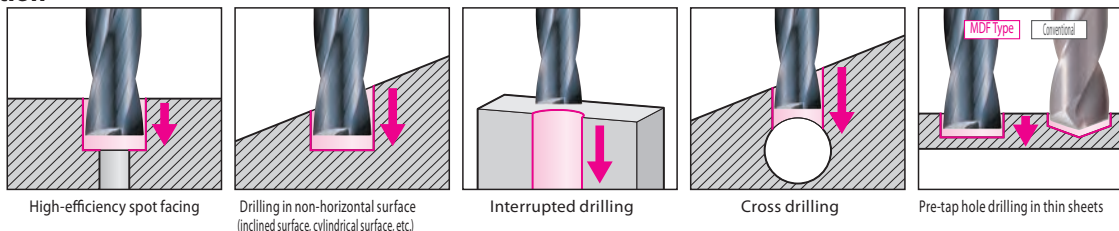

Recommended Cutting Conditions

1. The recommended hole depth is 2 x Dc. The depth is measured from the highest point of the hole on inclined surfaces.
2. The recommended cutting conditions are those for drilling on flat horizontal surfaces.
3. Adjust the feed rate according to the inclination angle when drilling on an inclined surface.
4. Set the feed rate at 70% or lower when the inclination angle is 30° or less.
5. Set the feed rate at 50% or lower when the inclination angle is larger than 30°.
6. This product is a drilling tool. Do not use it for traversing or helical milling.

v_c : Cutting Speed (SFM) f : Feed Rate (IPR)

Drill Diameter ϕD_c (mm)	Cutting Conditions	Soft Steel/General Steel (Up to 250HB)	Alloy Steel (Up to 300HB)	Hardened steel (Up to HRC50)	Stainless Steel (Up to 200HB)	Grey Cast Iron FC250	Ductile Cast Iron	Aluminum Alloy
~ $\phi 5$	v_c (SFM)	100 - 130 - 160	100 - 115 - 130	50 - 65 - 85	50 - 65 - 85	100 - 130 - 160	65 - 100 - 130	200 - 260 - 330
	f (IPR)	.00016 - .0002 - .00024	.00016 - .0002 - .00024	.00004 - .00008 - .00012	.00012 - .00016 - .0002	.00016 - .0002 - .00024	.00004 - .00012 - .0002	.00012 - .0002 - .00028
~ $\phi 1$	v_c (SFM)	145 - 180 - 215	115 - 145 - 215	65 - 100 - 130	65 - 85 - 100	145 - 180 - 215	100 - 130 - 160	260 - 330 - 400
	f (IPR)	.0004 - .0012 - .00020	.0004 - .0012 - .00020	.00008 - .00024 - .0004	.0002 - .00028 - .0004	.0004 - .0012 - .0020	.0002 - .0004 - .0006	.0004 - .0006 - .0008
~ $\phi 2$	v_c (SFM)	160 - 200 - 230	130 - 160 - 200	65 - 100 - 130	65 - 100 - 130	160 - 200 - 230	145 - 180 - 215	295 - 360 - 430
	f (IPR)	.0008 - .0012 - .0016	.0008 - .0012 - .0016	.0004 - .0007 - .001	.0004 - .0006 - .0008	.0008 - .0016 - .0024	.0006 - .0012 - .0018	.0012 - .002 - .0028
~ $\phi 4$	v_c (SFM)	200 - 250 - 295	160 - 215 - 265	65 - 100 - 130	65 - 100 - 130	200 - 250 - 295	160 - 215 - 250	295 - 360 - 430
	f (IPR)	.0024 - .0032 - .0004	0.002 - 0.0032 - 0.004	.0004 - .0008 - .0012	.0004 - .0008 - .0012	.0024 - .0032 - 0.004	.0016 - .0024 - .0032	.0024 - .0032 - 0.004
~ $\phi 6$	v_c (SFM)	200 - 250 - 295	160 - 215 - 265	65 - 100 - 130	65 - 100 - 160	200 - 250 - 295	200 - 230 - 265	295 - 360 - 430
	f (IPR)	0.002 - 0.004 - 0.006	0.002 - 0.004 - 0.006	.0016 - .0024 - .0032	.0012 - .002 - .0024	.002 - .004 - .006	.0024 - .0035 - .005	.002 - 0.004 - .006
~ $\phi 8$	v_c (SFM)	200 - 250 - 295	160 - 215 - 265	65 - 100 - 130	65 - 100 - 160	200 - 250 - 295	200 - 230 - 265	295 - 360 - 430
	f (IPR)	.004 - .006 - .008	.004 - .006 - .008	.0024 - .0032 - .004	.0016 - .0024 - .0032	.004 - .006 - .008	.004 - .0047 - .006	.004 - .006 - .008
~ $\phi 10$	v_c (SFM)	200 - 250 - 295	160 - 215 - 265	65 - 100 - 130	65 - 100 - 160	200 - 250 - 295	200 - 230 - 265	295 - 360 - 430
	f (IPR)	.0047 - .0067 - .0087	.0047 - .0067 - .0087	.0032 - .004 - .0047	.0024 - .0032 - .004	.0047 - .0067 - .0087	.0047 - .006 - .007	.0047 - .0067 - .0087
~ $\phi 12$	v_c (SFM)	200 - 250 - 295	160 - 215 - 265	65 - 100 - 130	65 - 100 - 160	200 - 250 - 295	200 - 230 - 265	295 - 360 - 430
	f (IPR)	.006 - .008 - .001	.006 - .008 - .01	.0047 - .006 - .007	.003 - .004 - .0047	.006 - .008 - .01	.006 - .007 - .008	.006 - .008 - .01
~ $\phi 16$	v_c (SFM)	200 - 250 - 295	160 - 215 - 265	65 - 100 - 130	65 - 100 - 160	200 - 250 - 295	200 - 230 - 265	295 - 360 - 430
	f (IPR)	.008 - .01 - .012	.008 - .01 - .012	.005 - .0067 - .008	.004 - .006 - .008	.0067 - .0087 - .011	.006 - .008 - .01	.008 - .01 - .012
~ $\phi 20$	v_c (SFM)	200 - 250 - 295	160 - 215 - 265	65 - 100 - 130	65 - 100 - 160	200 - 250 - 295	200 - 230 - 265	295 - 360 - 430
	f (IPR)	.01 - .012 - .014	.01 - .012 - .014	.006 - .0075 - .0087	.006 - .008 - .01	.008 - .01 - .012	.008 - .01 - .012	.01 - .012 - .014

Min. - Optimum - Max.



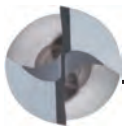

Flat Bottom Solid Carbide Drills

Flat MULTIDRILL

MDF Type



External Coolant Supply (MDF Type)

Carbon Steel	Alloy Steel	Tempered Steel	Hardened Steel	Stainless steel	Ti Alloy	Heat-resistant steel	Cast Iron	Ductile Cast Iron	Aluminium Alloy	Copper alloy	Composite CFRP
Up to 0.28%	From 0.28%	Steel	Up to 45HRC	From 48HRC							

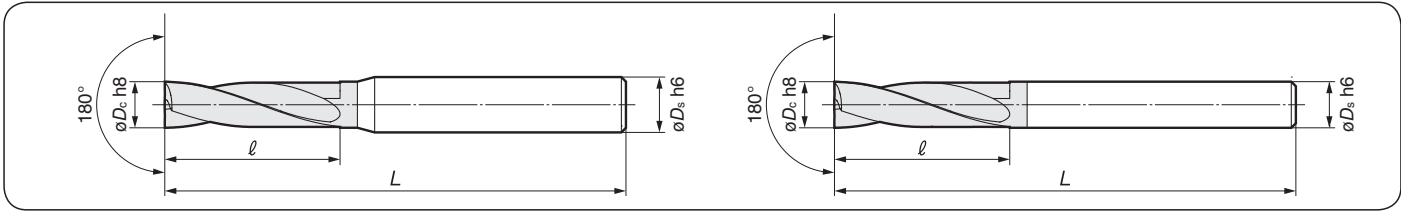

● Diameter ø0.3 to ø7.0mm

Diameter øD _c (mm)	Shank øD _s (mm)	Cat. No.	Stock	Dimensions (mm)	
				L	ℓ
0.3	3.0	MDF0030S2D	★	40	1.0
0.4		MDF0040S2D	★		1.4
0.5	3.0	MDF0050S2D	★	40	2.0
0.6		MDF0060S2D	★		2.4
0.7	3.0	MDF0070S2D	★	40	2.8
0.8		MDF0080S2D	★		3.2
0.9	3.0	MDF0090S2D	★	45	3.6
1.0		MDF0100S2D	★		4.0
1.1	3.0	MDF0110S2D	★	45	4.4
1.2		MDF0120S2D	★		4.8
1.3	3.0	MDF0130S2D	★	45	5.2
1.4		MDF0140S2D	★		5.6
1.5	3.0	MDF0150S2D	★	45	6.0
1.6		MDF0160S2D	★		6.4
1.7	3.0	MDF0170S2D	★	50	6.8
1.8		MDF0180S2D	★		7.2
1.9	3.0	MDF0190S2D	★	50	7.6
2.0		MDF0200S2D	★		8.0
2.1	4.0	MDF0210S2D	★	50	8.4
2.2		MDF0220S2D	★		8.8
2.3	4.0	MDF0230S2D	★	50	9.2
2.4		MDF0240S2D	★		9.6
2.5	4.0	MDF0250S2D	★	50	10.0
2.6		MDF0260S2D	★		10.4
2.7	4.0	MDF0270S2D	★	50	10.8
2.8		MDF0280S2D	★		11.2
2.9	4.0	MDF0290S2D	★	50	11.6
3.0		MDF0300S2D	★		12.0
3.1	6.0	MDF0310S2D	★	50	12.4
3.2		MDF0320S2D	★		12.8
3.3	6.0	MDF0330S2D	★	50	13.2
3.4		MDF0340S2D	★		13.6
3.5	6.0	MDF0350S2D	★	50	14.0
3.6		MDF0360S2D	★		14.4
3.7	6.0	MDF0370S2D	★	60	14.8
3.8		MDF0380S2D	★		15.2
3.9	6.0	MDF0390S2D	★	60	15.6
4.0		MDF0400S2D	★		16.0
4.1	6.0	MDF0410S2D	★	60	16.4
4.2		MDF0420S2D	★		16.8
4.3	6.0	MDF0430S2D	★	60	17.2
4.4		MDF0440S2D	★		17.6
4.5	6.0	MDF0450S2D	★	60	18.0
4.6		MDF0460S2D	★		18.4
4.7	6.0	MDF0470S2D	★	60	18.8
4.8		MDF0480S2D	★		19.2
4.9	6.0	MDF0490S2D	★	60	19.6
5.0		MDF0500S2D	★		20.0
5.1	6.0	MDF0510S2D	★	60	20.4
5.2		MDF0520S2D	★		20.8
5.3	6.0	MDF0530S2D	★	60	21.2
5.4		MDF0540S2D	★		21.6
5.5	6.0	MDF0550S2D	★	60	22.0
5.6		MDF0560S2D	★		22.4
5.7	6.0	MDF0570S2D	★	60	22.8
5.8		MDF0580S2D	★		23.2
5.9	6.0	MDF0590S2D	★	60	23.6
6.0		MDF0600S2D	★		24.0
6.1	8.0	MDF0610S2D	★	70	24.4
6.2		MDF0620S2D	★		24.8
6.3	8.0	MDF0630S2D	★	70	25.2
6.4		MDF0640S2D	★		25.6
6.5	8.0	MDF0650S2D	★	70	26.0
6.6		MDF0660S2D	★		26.4
6.7	8.0	MDF0670S2D	★	70	26.8
6.8		MDF0680S2D	★		27.2
6.9	8.0	MDF0690S2D	★	70	27.6
7.0		MDF0700S2D	★		28.0

● Diameter ø7.1 to ø20.0mm

Diameter øD _c (mm)	Shank øD _s (mm)	Cat. No.	Stock	Dimensions (mm)	
				L	ℓ
7.1	8.0	MDF0710S2D	★	70	28.4
7.2		MDF0720S2D	★		28.8
7.3	8.0	MDF0730S2D	★	70	29.2
7.4		MDF0740S2D	★		29.6
7.5	8.0	MDF0750S2D	★	70	30.0
7.6		MDF0760S2D	★		30.4
7.7	8.0	MDF0770S2D	★	70	30.8
7.8		MDF0780S2D	★		31.2
7.9	8.0	MDF0790S2D	★	70	31.6
8.0		MDF0800S2D	★		32.0
8.1	10.0	MDF0810S2D	★	80	32.4
8.2		MDF0820S2D	★		32.8
8.3	10.0	MDF0830S2D	★	80	33.2
8.4		MDF0840S2D	★		33.6
8.5	10.0	MDF0850S2D	★	80	34.0
8.6		MDF0860S2D	★		34.4
8.7	10.0	MDF0870S2D	★	80	34.8
8.8		MDF0880S2D	★		35.2
8.9	10.0	MDF0890S2D	★	80	35.6
9.0		MDF0900S2D	★		36.0
9.1	10.0	MDF0910S2D	★	80	36.4
9.2		MDF0920S2D	★		36.8
9.3	10.0	MDF0930S2D	★	80	37.2
9.4		MDF0940S2D	★		37.6
9.5	10.0	MDF0950S2D	★	80	38.0
9.6		MDF0960S2D	★		38.4
9.7	10.0	MDF0970S2D	★	80	38.8
9.8		MDF0980S2D	★		39.2
9.9	10.0	MDF0990S2D	★	80	39.6
10.0		MDF1000S2D	★		40.0
10.1	12.0	MDF1010S2D	★	90	40.4
10.2		MDF1020S2D	★		40.8
10.3	12.0	MDF1030S2D	★	90	41.2
10.4		MDF1040S2D	★		41.6
10.5	12.0	MDF1050S2D	★	90	42.0
10.6		MDF1060S2D	★		42.4
10.7	12.0	MDF1070S2D	★	90	42.8
10.8		MDF1080S2D	★		43.2
10.9	12.0	MDF1090S2D	★	90	43.6
11.0		MDF1100S2D	★		44.0
11.1	12.0	MDF1110S2D	★	90	44.4
11.2		MDF1120S2D	★		44.8
11.3	12.0	MDF1130S2D	★	90	45.2
11.4		MDF1140S2D	★		45.6
11.5	12.0	MDF1150S2D	★	90	46.0
11.6		MDF1160S2D	★		46.4
11.7	12.0	MDF1170S2D	★	90	46.8
11.8		MDF1180S2D	★		47.2
11.9	12.0	MDF1190S2D	★	90	47.6
12.0		MDF1200S2D	★		48.0
12.5	14.0	MDF1250S2D	★	100	50.0
13.0		MDF1300S2D	★		52.0
13.5	14.0	MDF1350S2D	★	110	54.0
14.0		MDF1400S2D	★		56.0
14.5	16.0	MDF1450S2D	★	110	58.0
15.0		MDF1500S2D	★		60.0
15.5	16.0	MDF1550S2D	★	115	62.0
16.0		MDF1600S2D	★		64.0
16.5	18.0	MDF1650S2D	★	125	66.0
17.0		MDF1700S2D	★		68.0
17.5	18.0	MDF1750S2D	★	130	70.0
18.0		MDF1800S2D	★		72.0
18.5	20.0	MDF1850S2D	★	140	74.0
19.0		MDF1900S2D	★		76.0
19.5	20.0	MDF1950S2D	★	140	78.0
20.0		MDF2000S2D	★		80.0

Grade: ACF75

★ - World Wide Warehouse Item





SUMITOMO

CARBIDE - CBN - DIAMOND

1-800-950-5202

www.sumicarbide.com

DEEP HOLE CARBIDE DRILLS

Pages 475-480



Deep Hole
Carbide
Drills

DEEP HOLE CARBIDE DRILLS	PAGES
MDW-XHV Features & Benefits	476
XHV-12XD (INCH & METRIC)	477
XHV-20XD (INCH & METRIC)	478
MDW-PHV	479
XHT/PHT (METRIC)	480

FEATURES & BENEFITS

MDW-XHV

MDW-XHV Deep Hole Carbide Drills

Features & Benefits



■ Features & Benefits

- **Deep hole drilling**
New flute shape with improved chip evacuation during deep drilling. High-efficiency drilling to depths of over 30 times drill diameter ($V_f = 28$ IPM). Stable deep hole drilling with double margin design.
- **Longer tool life**
Special DEX coating provides long tool life in a variety of work material.
- **Eco-friendly**
Compatible with the MQL (Minimum Quantity Lubrication) system.

■ Application Examples

• **Automotive Component**
1045 steel (250HB)

Machine: Horizontal single axis NC machine
Coolant: MQL Air pressure 0.9MPa
MQL Volume Approx. 1cc/H

Pilot hole:

- $\phi 0.23 \times 0.47$ in ($\phi 5.73 \times 12$ mm)
- Drill point angle: 150°
- $V_c = 262.5$ SFM (80m/min)
- $f = 0.008$ IPR (0.20mm/min)

Deep hole:

- $\phi 0.22 \times 3.27$ in ($\phi 5.7 \times 83$ mm)
- $V_c = 262.5$ SFM (80m/min)
- $f = 0.010$ IPR (0.25mm/min)
- $V_f = 44$ IPM (1117mm/min)

⇒ **Tool Life: 250 parts**

• **Automotive Component**
Gray cast iron

Machine: Horizontal single axis NC machine
Coolant: MQL (volume 3cc/H) Air discharge 0.45 MPa

Pilot hole:

- $\phi 0.30 \times 0.51$ in ($\phi 7.63 \times 13$ mm)
- Drill point angle: 150°
- $V_c = 262.5$ SFM (80m/min)
- $f = 0.010$ IPR (0.25mm/min)

Deep hole:

- $\phi 0.30 \times 9.10$ in ($\phi 7.60 \times 230$ mm)
- $V_c = 197$ SFM (60m/min)
- $f = 0.011$ IPR (0.30mm/min)
- $V_f = 29.70$ IPM (754mm/min)

⇒ **Tool Life: 500 parts**

■ Recommended Drilling Method

1. Make a guide hole using the MDW-PHV type drill

- Use a guide hole MDW-PHV style drill with diameter the same as the MDW-XHV type

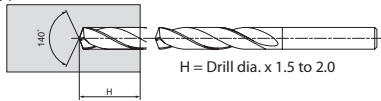

2. Feed the MDW-XHV type through the guide hole at low rotation speed

- Rotation: 500 rpm Feed Rate: 40 - 80 ipm

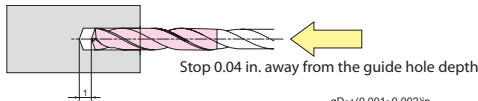

OTHER NOTES

- A flat base should be prepared when the surface for the guide tool is slanted
- When drilling through a slanted surface, reduce the drill feed to 0.002 ipm before the drill exits

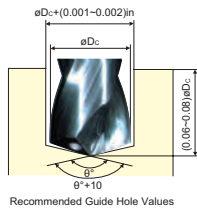

3. Increase rotation speed until the set rotation speed is reached and start normal drilling

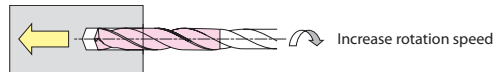

4. After drilling, rotation speed is reduced and the drill is retracted from the work material

- Rotation: 500 rpm Feed Rate: 40 - 80 ipm

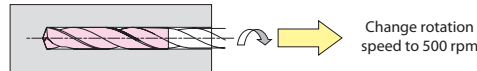

COOLANT

- Internal Coolant
(Water Soluble): Pump Pressure Steel: 200-300 PSI
Cast Iron or Aluminum: 500-1000 PSI
- Internal MQL: Air Pressure: 50-100 PSI or above
Volume (Edge)

■ Recommended Cutting Conditions

$V_c = \text{sfm} / \text{m/min}$
 $f = \text{ipr} / \text{mm/rev}$

		General Steel (>300HB)	Hardened Steel (>45HrC)	Stainless Steel (>200HB)	Gray Cast Iron	Ductile Iron
~ $\phi 0.125$ in ~ $\phi 3.0$ mm	Vc	165~330 / 50~100	65~130 / 20~40	100~165 / 30~50	165~295 / 50~90	130~260 / 40~80
	f	0.003~0.006 / 0.08~0.15	0.002~0.003 / 0.06~0.05	0.002~0.005 / 0.06~0.12	0.006~0.010 / 0.15~0.25	0.005~0.008 / 0.12~0.20
$\phi 0.125 \sim \phi 0.203$ in $\phi 3.1 \sim \phi 5.0$ mm	Vc	260~395 / 80~120	65~130 / 20~40	100~195 / 30~60	165~295 / 50~90	130~260 / 40~80
	f	0.006~0.010 / 0.15~0.25	0.003~0.004 / 0.08~0.10	0.003~0.006 / 0.08~0.15	0.006~0.012 / 0.15~0.30	0.006~0.010 / 0.15~0.25
$\phi 0.203 \sim \phi 0.406$ in $\phi 5.1 \sim \phi 10.0$ mm	Vc	260~395 / 80~120	65~130 / 20~40	130~260 / 40~80	195~330 / 60~100	165~295 / 50~90
	f	0.008~0.014 / 0.20~0.35	0.004~0.006 / 0.10~0.15	0.004~0.008 / 0.10~0.20	0.008~0.014 / 0.20~0.35	0.008~0.014 / 0.20~0.35
$\phi 0.406 \sim \phi 0.625$ in $\phi 10.1 \sim \phi 16.0$ mm	Vc	260~425 / 80~130	65~130 / 20~40	165~260 / 50~80	230~395 / 70~120	195~330 / 60~100
	f	0.010~0.014 / 0.25~0.35	0.004~0.006 / 0.10~0.15	0.004~0.008 / 0.10~0.20	0.010~0.014 / 0.25~0.35	0.010~0.014 / 0.25~0.35



MDW-XHV Deep Hole Carbide Coolant Through Drills

12XD MDW-XHV



Tolerance of Diameters	
øD	Tolerance
.1181 < øD ≤ .2362	-.00080 -.00145
.2362 < øD ≤ .3937	-.00080 -.00165
.3937 < øD ≤ .7087	-.00080 -.00185

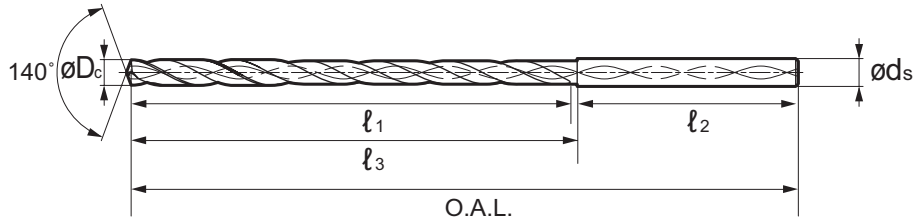

12XD-INCH

Catalog Number	Stock	Cutting Dia. øD _c		O.A.L.	l ₃	l ₂	l ₁	ød _s
		Fraction	Decimal					
MDW1250XHV12	●	1/8"	0.125	3.780	1.890	1.890	1.772	0.157
MDW1406XHV12	●	9/64"	0.141	4.134	2.244	1.890	2.126	0.157
MDW1563XHV12	●	5/32"	0.156	4.370	2.480	1.890	2.362	0.157
MDW1719XHV12	●	11/64"	0.172	4.607	2.638	1.969	2.520	0.236
MDW1875XHV12	●	3/16"	0.188	5.158	3.189	1.969	3.071	0.236
MDW2031XHV12	●	13/64"	0.203	5.158	3.189	1.969	3.071	0.236
MDW2131XHV12	●	#3	0.213	5.158	3.189	1.969	3.071	0.236
MDW2187XHV12	●	7/32"	0.219	5.433	3.465	1.969	3.346	0.236
MDW2500XHV12	●	1/4"	0.250	6.102	4.055	2.047	3.937	0.315
MDW2570XHV12	●	#F	0.257	6.102	4.055	2.047	3.937	0.315
MDW2656XHV12	●	17/64"	0.266	6.102	4.055	2.047	3.937	0.315
MDW2813XHV12	●	9/32"	0.281	6.496	4.449	2.047	4.331	0.315
MDW2969XHV12	●	19/64"	0.297	6.496	4.449	2.047	4.331	0.315
MDW3125XHV12	●	5/16"	0.313	6.496	4.449	2.047	4.331	0.315
MDW3320XHV12	●	#Q	0.332	7.677	5.551	2.126	5.433	0.394
MDW3438XHV12	●	11/32"	0.344	7.677	5.551	2.126	5.433	0.394
MDW3594XHV12	●	23/64"	0.359	7.677	5.551	2.126	5.433	0.394
MDW3750XHV12	●	3/8"	0.375	7.677	5.551	2.126	5.433	0.394
MDW3906XHV12	●	25/64"	0.391	7.677	5.551	2.126	5.433	0.394
MDW4063XHV12	●	13/32"	0.406	8.543	6.339	2.205	6.220	0.472
MDW4219XHV12	●	27/64"	0.422	8.543	6.339	2.205	6.220	0.472
MDW4375XHV12	●	7/16"	0.438	8.543	6.339	2.205	6.220	0.472
MDW4531XHV12	●	29/64"	0.453	8.543	6.339	2.205	6.220	0.472
MDW4688XHV12	●	15/32"	0.469	8.543	6.339	2.205	6.220	0.472
MDW4844XHV12	●	31/64"	0.484	9.566	7.283	2.283	7.165	0.551
MDW5000XHV12	●	1/2"	0.500	9.566	7.283	2.283	7.165	0.551
MDW5312XHV12	●	17/32"	0.531	9.566	7.283	2.283	7.165	0.551
MDW5625XHV12	●	9/16"	0.563	10.669	8.307	2.362	8.189	0.630
MDW6250XHV12	●	5/8"	0.625	10.669	8.307	2.362	8.189	0.630
MDW7500XHV12	●	3/4"	0.750	12.709	10.268	2.441	10.157	0.787

● = USA Stocked item

12XD-METRIC

Catalog Number	Stock	øD _c	O.A.L.	l ₃	l ₂	l ₁	ød _s
MDW030XHV12	●	3.0	96	48	48	45	4
MDW035XHV12	●	3.5	105	57	48	54	4
MDW040XHV12	●	4.0	111	63	48	60	4
MDW045XHV12	●	4.5	117	67	50	64	6
MDW050XHV12	●	5.0	131	81	50	78	6
MDW051XHV12	●	5.1	131	81	50	78	6
MDW055XHV12	●	5.5	138	88	50	85	6
MDW060XHV12	●	6.0	138	88	50	85	6
MDW065XHV12	●	6.5	155	103	52	100	8
MDW069XHV12	●	6.9	165	113	52	110	8
MDW070XHV12	●	7.0	165	113	52	110	8
MDW075XHV12	●	7.5	165	113	52	110	8
MDW080XHV12	●	8.0	165	113	52	110	8
MDW085XHV12	●	8.5	195	141	54	138	10
MDW090XHV12	●	9.0	195	141	54	138	10
MDW093XHV12	●	9.3	195	141	54	138	10
MDW095XHV12	●	9.5	195	141	54	138	10
MDW100XHV12	●	10.0	195	141	54	138	10
MDW105XHV12	●	10.5	217	161	56	158	12
MDW110XHV12	●	11.0	217	161	56	158	12
MDW115XHV12	●	11.5	217	161	56	158	12
MDW120XHV12	●	12.0	217	161	56	158	12
MDW125XHV12	●	12.5	243	185	58	182	14
MDW130XHV12	●	13.0	243	185	58	182	14
MDW140XHV12	●	14.0	243	185	58	182	14





Tolerance of Diameters	
øD	Tolerance
.1181 < øD ≤ .2362	-0.0080 -0.0145
.2362 < øD ≤ .3937	-0.0080 -0.0165
.3937 < øD ≤ .7087	-0.0080 -0.0185

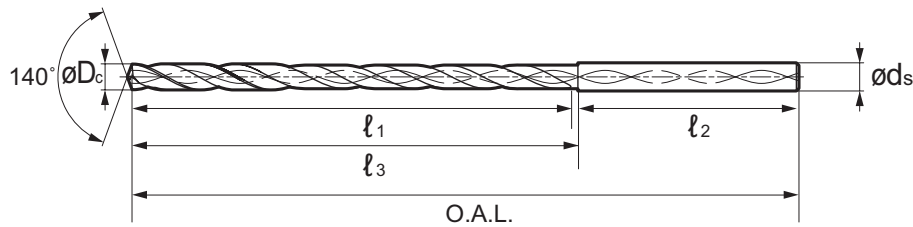

Deep Hole Carbide Drills

20XD-INCH

Catalog Number	Stock	Cutting Dia. øD _C		O.A.L.	l ₃	l ₂	l ₁	ød _s
		Fraction	Decimal					
MDW1250XHV20	●	1/8"	0.125	4.842	2.952	1.890	2.834	0.157
MDW1406XHV20	●	9/64"	0.141	5.472	3.582	1.890	3.464	0.157
MDW1563XHV20	●	5/32"	0.156	5.472	3.582	1.890	3.464	0.157
MDW1719XHV20	●	11/64"	0.172	6.418	4.449	1.969	4.331	0.236
MDW1875XHV20	●	3/16"	0.188	6.614	4.645	1.969	4.527	0.236
MDW2031XHV20	●	13/64"	0.203	6.614	4.645	1.969	4.527	0.236
MDW2131XHV20	●	#3	0.213	7.520	5.551	1.969	5.433	0.236
MDW2187XHV20	●	7/32"	0.219	7.520	5.551	1.969	5.433	0.236
MDW2500XHV20	●	1/4"	0.250	7.913	5.866	2.047	5.748	0.315
MDW2570XHV20	●	#F	0.257	7.913	5.866	2.047	5.748	0.315
MDW2656XHV20	●	17/64"	0.266	7.913	5.866	2.047	5.748	0.315
MDW2813XHV20	●	9/32"	0.281	9.094	7.047	2.047	6.929	0.315
MDW2969XHV20	●	19/64"	0.297	9.094	7.047	2.047	6.929	0.315
MDW3125XHV20	●	5/16"	0.313	9.094	7.047	2.047	6.929	0.315
MDW3320XHV20	●	#Q	0.332	10.905	8.779	2.126	8.661	0.394
MDW3438XHV20	●	11/32"	0.344	10.905	8.779	2.126	8.661	0.394
MDW3594XHV20	●	23/64"	0.359	10.905	8.779	2.126	8.661	0.394
MDW3750XHV20	●	3/8"	0.375	10.905	8.779	2.126	8.661	0.394
MDW3906XHV20	●	25/64"	0.391	10.905	8.779	2.126	8.661	0.394
MDW4063XHV20	●	13/32"	0.406	12.713	10.508	2.205	10.394	0.472
MDW4219XHV20	●	27/64"	0.422	12.713	10.508	2.205	10.394	0.472
MDW4375XHV20	●	7/16"	0.438	12.713	10.508	2.205	10.394	0.472
MDW4531XHV20	●	29/64"	0.453	12.713	10.508	2.205	10.394	0.472
MDW4688XHV20	●	15/32"	0.469	12.713	10.508	2.205	10.394	0.472
MDW4844XHV20	●	31/64"	0.484	14.521	12.238	2.283	12.126	0.551
MDW5000XHV20	●	1/2"	0.500	14.521	12.238	2.283	12.126	0.551
MDW5312XHV20	●	17/32"	0.531	14.521	12.238	2.283	12.126	0.551

● = USA Stocked item

20XD-METRIC

Catalog Number	Stock	øD _C	O.A.L.	l ₃	l ₂	l ₁	ød _s
MDW030XHV20	●	3.0	123.0	75	48	72.0	4
MDW035XHV20	●	3.5	139.0	91	48	88.0	4
MDW040XHV20	●	4.0	139.0	91	48	88.0	4
MDW045XHV20	●	4.5	163.0	113	50	110.0	6
MDW050XHV20	●	5.0	168.0	118	50	115.0	6
MDW051XHV20	●	5.1	168.0	118	50	115.0	6
MDW055XHV20	●	5.5	191.0	141	50	138.0	6
MDW060XHV20	●	6.0	191.0	141	50	138.0	6
MDW065XHV20	●	6.5	201.0	149	52	146.0	8
MDW069XHV20	●	6.9	231.0	179	52	176.0	8
MDW070XHV20	●	7.0	231.0	179	52	176.0	8
MDW075XHV20	●	7.5	231.0	179	52	176.0	8
MDW080XHV20	●	8.0	231.0	179	52	176.0	8
MDW085XHV20	●	8.5	277.0	223	54	220.0	10
MDW090XHV20	●	9.0	277.0	223	54	220.0	10
MDW093XHV20	●	9.3	277.0	223	54	220.0	10
MDW095XHV20	●	9.5	277.0	223	54	220.0	10
MDW100XHV20	●	10.0	277.0	223	54	220.0	10
MDW105XHV20	●	10.5	322.9	267	56	264.0	12
MDW110XHV20	●	11.0	322.9	267	56	264.0	12
MDW115XHV20	●	11.5	322.9	267	56	264.0	12
MDW120XHV20	●	12.0	322.9	267	56	264.0	12
MDW125XHV20	●	12.5	368.8	311	58	308.0	14
MDW130XHV20	●	13.0	368.8	311	58	308.0	14
MDW140XHV20	●	14.0	368.8	311	58	308.0	14



**MDW-PHV Series Solid Carbide
Pilot Drills**

**SERIES
MDW-PHV**

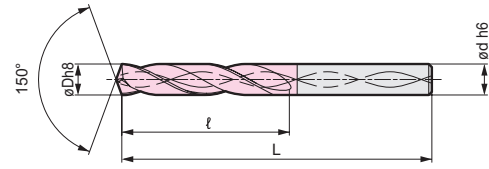
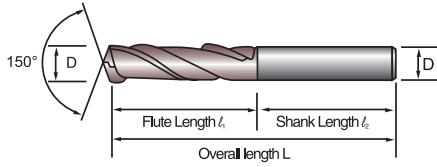

Catalog Number (inch/metric)	Stock	Fractional Wire & Letters	Diameter D (in)	Diameter D (mm)	Overall Length L (in)	Flute Length ℓ ₁ (in)	Shank Length ℓ ₂ (in)	Shank Diameter D _s (mm)
MDW0300PHV	•		0.1181	3.00	2.672	0.703	1.891	6.00
MDW01250PHV	•	1/8	0.1250	3.18	2.672	0.703	1.891	6.00
MDW0350PHV	•		0.1378	3.50	2.828	0.703	1.891	6.00
MDW01406PHV	•	9/64	0.1406	3.57	2.828	0.891	1.891	6.00
MDW01563PHV	•	5/32	0.1563	3.97	2.828	0.891	1.891	6.00
MDW0400PHV	•		0.1575	4.00	2.828	0.891	1.891	6.00
MDW01719PHV	•	11/64	0.1719	4.37	3.156	0.984	1.969	6.00
MDW0450PHV	•		0.1772	4.50	3.156	0.984	1.969	6.00
MDW01875PHV	•	3/16	0.1875	4.76	3.156	1.078	1.969	6.00
MDW0500PHV	•		0.1968	5.00	3.156	1.078	1.969	6.00
MDW0510PHV	•		0.2010	5.10	3.234	1.078	2.047	6.00
MDW02031PHV	•	13/64	0.2031	5.20	3.234	1.078	2.047	6.00
MDW02131PHV	•	#3	0.2131	5.41	3.234	1.078	2.047	6.00
MDW0550PHV	•		0.2165	5.50	3.234	1.078	2.047	6.00
MDW02187PHV	•	7/32	0.2187	5.56	3.234	1.078	2.047	6.00
MDW0600PHV	•		0.2362	6.00	3.234	1.188	2.047	6.00
MDW02500PHV	•	1/4	0.2500	6.35	3.469	1.281	2.094	8.00
MDW0650PHV	•		0.2559	6.50	3.469	1.281	2.094	8.00
MDW02570PHV	•	#F	0.2570	6.53	3.469	1.375	2.094	8.00
MDW02656PHV	•	17/64	0.2656	6.75	3.469	1.375	2.094	8.00
MDW0690PHV	•		0.2716	6.90	3.469	1.375	2.094	8.00
MDW0700PHV	•		0.2726	7.00	3.469	1.375	2.094	8.00
MDW02813PHV	•	9/32	0.2813	7.14	3.703	1.484	2.125	8.00
MDW0750PHV	•		0.2953	7.50	3.703	1.484	2.125	8.00
MDW02969PHV	•	19/64	0.2969	7.54	3.703	1.474	2.125	8.00
MDW03125PHV	•	5/16	0.3125	7.94	3.703	1.578	2.125	8.00
MDW0800PHV	•		0.3149	8.00	3.703	1.578	2.125	8.00
MDW03281PHV	•	21/64	0.3281	8.33	3.938	1.672	2.156	10.00
MDW03320PHV	•	#Q	0.3320	8.43	3.938	1.672	2.156	10.00
MDW0850PHV	•		0.3346	8.50	3.938	1.672	2.156	10.00
MDW03438PHV	•	11/32	0.3438	8.73	3.938	1.766	2.156	10.00
MDW0900PHV	•		0.3543	9.00	3.938	1.766	2.156	10.00
MDW03594PHV	•	23/64	0.3594	9.13	3.938	1.766	2.156	10.00
MDW0930PHV	•		0.3661	9.30	4.172	1.875	2.203	10.00
MDW0950PHV	•		0.3740	9.50	4.172	1.875	2.203	10.00
MDW03750PHV	•	3/8	0.3750	9.53	4.172	1.875	2.203	10.00
MDW03906PHV	•	25/64	0.3906	9.92	4.172	1.969	2.203	10.00
MDW1000PHV	•		0.3937	10.00	4.172	1.969	2.203	10.00
MDW1020PHV	•		0.4016	10.20	4.563	2.047	2.406	12.00
MDW04063PHV	•	13/32	0.4063	10.32	4.563	2.047	2.406	12.00
MDW1050PHV	•		0.4134	10.50	4.563	2.047	2.406	12.00
MDW04219PHV	•	27/64	0.4219	10.72	4.563	2.172	2.406	12.00
MDW1100PHV	•		0.4331	11.00	4.563	2.172	2.406	12.00
MDW04375PHV	•	7/16	0.4375	11.11	4.563	2.172	2.406	12.00
MDW1150PHV	•		0.4527	11.50	4.813	2.281	2.438	12.00
MDW04531PHV	•	29/64	0.4531	11.51	4.813	2.281	2.438	12.00
MDW04688PHV	•	15/32	0.4688	11.91	4.813	2.359	2.438	12.00
MDW1200PHV	•		0.4724	12.00	4.813	2.359	2.438	12.00
MDW04844PHV	•	31/64	0.4844	12.30	5.032	2.469	2.484	14.00
MDW1250PHV	•		0.4921	12.50	5.032	2.469	2.484	14.00
MDW05000PHV	•	1/2	0.5000	12.70	5.032	2.562	2.484	14.00
MDW1300PHV	•		0.5118	13.00	5.032	2.562	2.484	14.00
MDW05312PHV	•	17/32	0.5312	13.49	5.281	2.656	2.516	14.00
MDW1400PHV	•		0.5512	14.00	5.281	2.750	2.516	14.00
MDW05625PHV	•	9/16	0.5625	14.29	5.516	2.859	2.562	16.00
MDW06250PHV	•	5/8	0.6250	15.88	5.750	3.156	2.594	16.00
MDW07500PHV	•	3/4	0.7500	19.05	6.453	3.750	2.719	20.00

Solid Carbide Drills



MDW-XHT

MDW-XHT Deep Hole

Carbide Coolant Through Drills

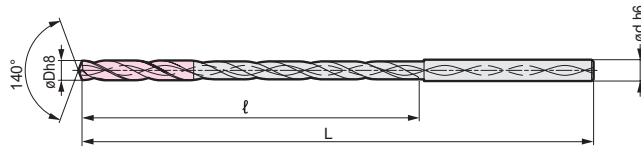

MDW-XHT-METRIC

Tool Dia. ϕD_c (mm)	Shank Dia. ϕD_s (mm)	Catalog Number	15XD			25XD			30XD		
			Stock	Dimensions (mm)		Stock	Dimensions (mm)		Stock	Dimensions (mm)	
				L	ℓ		L	ℓ		L	ℓ
2.97	3.0	MDW0297XHT□□	★	108	60	★	138	90	★	153	105
3.47	4.0	MDW0347XHT□□	★	118	70	★	153	105	★	171	123
3.97	4.0	MDW0397XHT□□	★	128	80	★	168	120	★	188	140
4.47	5.0	MDW0447XHT□□	★	140	90	★	185	135	★	208	158
4.97	5.0	MDW0497XHT□□	★	150	100	★	200	150	★	225	175
5.47	6.0	MDW0547XHT□□	★	162	110	★	217	165	★	245	193
5.97	6.0	MDW0597XHT□□	★	172	120	★	232	180	★	262	210
6.47	7.0	MDW0647XHT□□	★	183	130	★	248	195	★	281	228
6.97	7.0	MDW0697XHT□□	★	193	140	★	263	210	★	298	245
7.47	8.0	MDW0747XHT□□	★	204	150	★	279	225	★	317	263
7.97	8.0	MDW0797XHT□□	★	214	160	★	294	240	★	334	280

★ = Worldwide Warehouse item available in 10 business days

NOTE: MDW-PHT is the recommended guide drill for the XHT series. Use a guide hole drill with a diameter +0.001 to +0.002 inch larger than that of the MDW-XHT type.

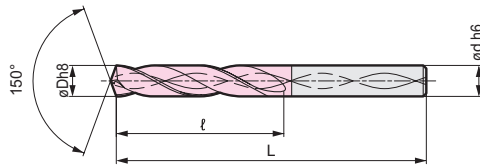

MDW-PHT-METRIC

Tool Dia. ϕD_c (mm)	Shank Dia. ϕD_s (mm)	Catalog Number	Guide Hole Drill		
			Stock	Dimensions (mm)	
				L	ℓ
3.0	3.0	MDW0300PHT□□	★	68	17.5
3.5	4.0	MDW0350PHT□□	★	72	20.0
4.0	4.0	MDW0400PHT□□	★	72	22.5
4.5	5.0	MDW0450PHT□□	★	80	25.0
5.0	5.0	MDW0500PHT□□	★	80	27.5
5.5	6.0	MDW0550PHT□□	★	82	27.5
6.0	6.0	MDW0600PHT□□	★	82	30.0
6.5	7.0	MDW0650PHT□□	★	88	32.5
7.0	7.0	MDW0700PHT□□	★	88	35.0
7.5	8.0	MDW0750PHT□□	★	94	37.5
8.0	8.0	MDW0800PHT□□	★	94	40.0

★ = Worldwide Warehouse item available in 10 business days



Deep Hole Carbide Drills

SMALL DIAMETER & DLC COATED DRILLS

Pages 481-487

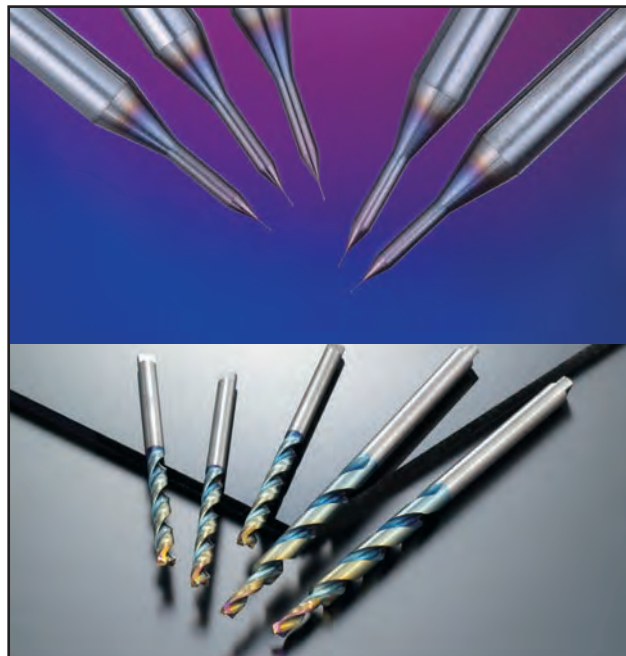

MicroDrills/DLC Coated Drills

SMALL DIA. & DLC COATED DRILLS PAGES

Small Diameter Drills

MLDH Type	482-483
MDUS Type	484
MDSS Type	485

DLC Coated Drills

NHGS Type	486-487
-----------------	---------

Micro Long Drills MLDH-L / MLDH-P Type



General Features

Micro Long Drills are oil-hole drills for high efficiency drilling that were developed for drilling deep, small-diameter holes. These next-generation, small-diameter hole drills feature improved strength - often a problem area with small-diameter drills.

Characteristics and Applications

Deep-hole drilling

New groove shape ensures good drill rigidity and chip evacuation.

High efficiency drilling to depths of over 20x drill diameter at over $v_f=500\text{mm/min}$ (drill diameter 1.3mm, SUS416 equivalent).

Optimal thinning and edge balance for stable chip control.

Long tool life

Special coating provides long tool life with a wide variety of work materials.

Improved chip evacuation makes it possible to reduce spindle load fluctuation, ensuring stable tool life.

Series

Application	Series	Diameter Range (mm)	Hole Depth ($1/\phi$)
Deep Hole Drilling	MLDH□□□□L5 Type	ø0.8 to 2.0	Up to 5
	MLDH□□□□L12 Type	ø0.8 to 2.0	Up to 12
	MLDH□□□□L20 Type	ø0.8 to 2.0	Up to 20
	MLDH□□□□L30 Type	ø0.8 to 2.0	Up to 30
Guide Hole Drilling	MLDH□□□□P Type	ø0.8 to 2.0	Up to 2

Recommended Cutting Conditions

MLDH-P Type/MLDH-L5 Type

(v_c : Cutting Speed SFM f: Feed Rate IPR)

Drill Diameter ϕD_c (mm)	Cutting Conditions	Soft Steel Up to 200HB	General Steel Up to 250HB	Alloy Steel Up to 300HB	Stainless Steel Up to 200HB	Cast Iron FC/FCD	Aluminium Alloy	Heat-resistant steels
Up to 1.0	v_c	130 - 160 - 200	130 - 160 - 200	130 - 160 - 200	65 - 100 - 130	130 - 160 - 200	160 - 200 - 230	15 - 32 - 50
	f	.0004 - .0008 - .0012	.0004 - .0008 - .0012	.0004 - .0008 - .0012	.0004 - .0008 - .0012	.0008 - .0012 - .0016	.0012 - .0016 - .0024	.0002 - .0004 - .0008
Up to 1.5	v_c	130 - 160 - 200	130 - 160 - 200	130 - 160 - 200	65 - 100 - 130	130 - 160 - 200	160 - 200 - 230	15 - 32 - 50
	f	.0016 - .0032 - .0048	.0016 - .0032 - .0048	.0016 - .0032 - .0048	.0008 - .002 - .004	.0016 - .0032 - .0048	.002 - .004 - .006	.0004 - .0012 - .002
Up to 2.0	v_c	130 - 160 - 200	130 - 160 - 200	130 - 160 - 200	65 - 100 - 130	130 - 160 - 200	160 - 200 - 230	15 - 32 - 50
	f	.0024 - .0032 - .0048	.0024 - .0032 - .0048	.0024 - .0032 - .0048	.0016 - .0024 - .004	.0024 - .0032 - .0048	.0032 - .0048 - .006	.0004 - .0012 - .002

Min. - Optimum - Max.

MLDH-L12 Type/MLDH-L20 Type/MLDH-L30 Type

Drill Diameter ϕD_c (mm)	Cutting Conditions	Soft Steel Up to 200HB	General Steel Up to 250HB	Alloy Steel Up to 300HB	Stainless Steel Up to 200HB	Cast Iron FC/FCD	Aluminium Alloy	Heat-resistant steels
Up to 1.0	v_c	130 - 160 - 200	130 - 160 - 200	130 - 160 - 200	65 - 100 - 130	130 - 160 - 200	160 - 200 - 230	15 - 32 - 50
	f	.0004 - .0008 - .0012	.0004 - .0008 - .0012	.0004 - .0008 - .0012	.0004 - .0008 - .0012	.0008 - .0012 - .0016	.0012 - .0016 - .0024	.0002 - .0004 - .0008
Up to 1.5	v_c	130 - 160 - 200	130 - 160 - 200	130 - 160 - 200	65 - 100 - 130	130 - 160 - 200	160 - 200 - 230	15 - 32 - 50
	f	.0012 - .002 - .0028	.0012 - .002 - .0028	.0012 - .002 - .0028	.0008 - .0016 - .0028	.0016 - .0028 - .004	.002 - .0032 - .0048	.0004 - .0008 - .0012
Up to 2.0	v_c	130 - 160 - 200	130 - 160 - 200	130 - 160 - 200	65 - 100 - 130	130 - 160 - 200	160 - 200 - 230	15 - 32 - 50
	f	.0016 - .0024 - .0032	.0016 - .0024 - .0032	.0016 - .0024 - .0032	.0016 - .0024 - .0032	.0016 - .0028 - .004	.002 - .0032 - .0048	.0004 - .0008 - .0012

Min. - Optimum - Max.

Application Examples

Automotive Component Mould (Equivalent to SUS416)

Tool : MLDH1400L20 (Guide : MLDH1400P)

Equipment : Vertical Machining Centre (HSKA63)

Coolant Supply : Internal Coolant (Emulsion Type, Pump Pressure : 4MPa)

Cutting Conditions : $v_c=200\text{ SFM}$ $f=0.00112\text{ IPR}$ $H=0.83''$

Tool Life : 600 Units

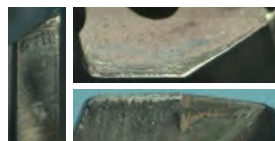

Tooling Component (Equivalent to SKD11)

Tool : MLDH1900L20 (Guide : MLDH1900P)

Equipment : Vertical Machining Centre (HSKA63)

Coolant Supply : Internal Coolant (Emulsion Type, Pump Pressure : 4MPa)

Cutting Conditions : $v_c=200\text{ SFM}$ $f=0.004\text{ IPR}$ $H=1.063''$

Tool Life : 600 Units

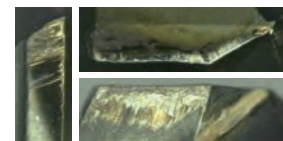



■ MDUS-Features & Benefits

- **High precision shank**
Shank tolerance: h3
Concentricity: 0.3µm or less
Roundness: 0.5µm or less
- **New ultra-thin TiAlN coating**
Provides improved wear resistance
- **Wide material range**
Ideal for machining steel, stainless steel, and copper

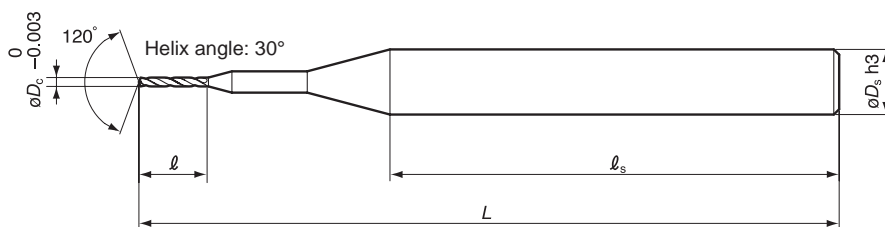

ø0.030 to ø0.180mm

Catalog Number	øDc (mm)	øDs (mm)	Stock	Dimensions (mm)		
				l	ls	L
MDUS0030-30C	0.030	3.0	★	0.3	28	38
MDUS0040-30C	0.040		★	0.4		
MDUS0050-30C	0.050		★	0.5		
MDUS0080-30C	0.080		★	0.8		
MDUS0100-30C	0.100		★	1.0		
MDUS0120-30C	0.120		★	1.2		
MDUS0150-30C	0.150		★	1.5		
MDUS0180-30C	0.180		★	1.8		

★ = Worldwide Warehouse item available in 10 business days

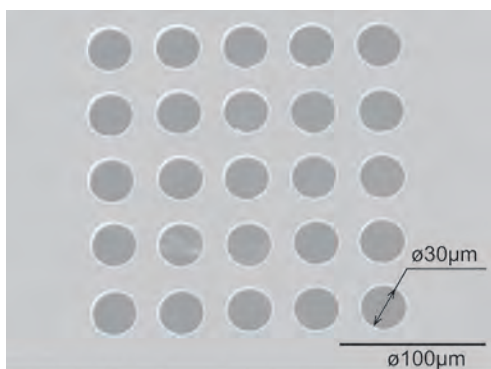

Material: 304 Stainless Steel
Drill: MDUS0030-30C (ø0.03mm)





■ Features & Benefits

- High breakage resistance due to a combination of tough, stable carbide substrate and a highly rigid design
- Long tool life is achieved as a result of the PVD coating created especially for small diameter drills
- Wide variety of applications including carbon steel, alloy steel, die steel, and stainless steel

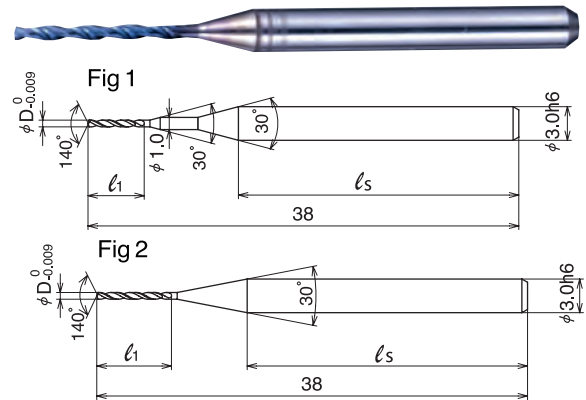

ø0.20 to ø0.49mm

ø0.50 to ø0.79mm

Catalog Number	Stock	øDc (mm)	Dimensions (mm)		Style	Catalog Number	Stock	øDc (mm)	Dimensions (mm)		Style	Catalog Number	Stock	øDc (mm)	Dimensions (mm)		Style
			ℓ	ℓ _s					ℓ	ℓ _s					ℓ	ℓ _s	
MDSS0020	★	0.20	2.5	28	Fig1	MDSS0050	★	0.50	6	27	Fig2	MDSS0080	★	0.80	10	23	Fig2
MDSS0021	★	0.21				MDSS0051	★	0.51				MDSS0081	★	0.81			
MDSS0022	★	0.22				MDSS0052	★	0.52				MDSS0082	★	0.82			
MDSS0023	★	0.23				MDSS0053	★	0.53				MDSS0083	★	0.83			
MDSS0024	★	0.24				MDSS0054	★	0.54				MDSS0084	★	0.84			
MDSS0025	★	0.25				MDSS0055	★	0.55				MDSS0085	★	0.85			
MDSS0026	★	0.26				MDSS0056	★	0.56				MDSS0086	★	0.86			
MDSS0027	★	0.27				MDSS0057	★	0.57				MDSS0087	★	0.87			
MDSS0028	★	0.28				MDSS0058	★	0.58				MDSS0088	★	0.88			
MDSS0029	★	0.29				MDSS0059	★	0.59				MDSS0089	★	0.89			
MDSS0030	★	0.30	3	28	Fig2	MDSS0060	★	0.60	7	26	Fig2	MDSS0090	★	0.90	11	22	Fig2
MDSS0031	★	0.31				MDSS0061	★	0.61				MDSS0091	★	0.91			
MDSS0032	★	0.32				MDSS0062	★	0.62				MDSS0092	★	0.92			
MDSS0033	★	0.33				MDSS0063	★	0.63				MDSS0093	★	0.93			
MDSS0034	★	0.34				MDSS0064	★	0.64				MDSS0094	★	0.94			
MDSS0035	★	0.35				MDSS0065	★	0.65				MDSS0095	★	0.95			
MDSS0036	★	0.36				MDSS0066	★	0.66				MDSS0096	★	0.96			
MDSS0037	★	0.37				MDSS0067	★	0.67				MDSS0097	★	0.97			
MDSS0038	★	0.38				MDSS0068	★	0.68				MDSS0098	★	0.98			
MDSS0039	★	0.39				MDSS0069	★	0.69				MDSS0099	★	0.99			
MDSS0040	★	0.40	4	28	Fig2	MDSS0070	★	0.70	9	24	Fig2	MDSS0100	★	1.00	12	21	Fig2
MDSS0041	★	0.41				MDSS0071	★	0.71									
MDSS0042	★	0.42				MDSS0072	★	0.72									
MDSS0043	★	0.43				MDSS0073	★	0.73									
MDSS0044	★	0.44				MDSS0074	★	0.74									
MDSS0045	★	0.45				MDSS0075	★	0.75									
MDSS0046	★	0.46				MDSS0076	★	0.76									
MDSS0047	★	0.47				MDSS0077	★	0.77									
MDSS0048	★	0.48				MDSS0078	★	0.78									
MDSS0049	★	0.49				MDSS0079	★	0.79									

★ = Worldwide Warehouse item available in 10 business days

- 1) The conditions above are recommended under wet conditions, using water-soluble coolant.
- 2) If machine noises and vibrations are present, adjust the cutting conditions accordingly.
- 3) If the machine cannot achieve the recommended spindle speed, use the maximum spindle speed available.

■ Recommended Cutting Conditions (Wet)

Feed Rate=ipm / mm/min		Structural Steel	Alloy Steel	Die Steel	Hardened Steel	Hardened Steel	Ductile Cast Iron	Stainless Steel
		Carbon Steel Gray Cast Iron	Pre-hardened Steel	Tempered Steel	40-50 HRC	50-55 HRC		
~ø.20 - ø.29 mm	RPM	31,800	26,500	21,200	12,700	10,600	31,800	10,600
	Feed Rate	2.362 / 60	1.969 / 50	1.575 / 40	1.181 / 30	0.787 / 20	2.362 / 60	0.787 / 20
	Step Feed	0.1XD	0.1XD	0.1XD	0.1XD	0.1XD	0.1XD	0.1XD
~ø.30 - .39 mm	RPM	31,800	26,500	21,200	12,700	10,600	31,800	10,600
	Feed Rate	3.937 / 100	3.150 / 80	2.362 / 60	1.575 / 40	1.181 / 30	3.937 / 100	1.181 / 30
	Step Feed	0.1XD	0.1XD	0.1XD	0.1XD	0.1XD	0.1XD	0.1XD
~ø.40 - .49 mm	RPM	31,800	25,900	19,900	12,700	9,900	31,800	9,500
	Feed Rate	5.118 / 130	3.937 / 100	3.150 / 80	1.969 / 50	1.575 / 40	5.118 / 130	1.575 / 40
	Step Feed	0.1XD	0.1XD	0.1XD	0.1XD	0.1XD	0.1XD	0.1XD
~ø.50 - .59 mm	RPM	31,800	25,500	19,100	12,700	9,500	31,800	9,500
	Feed Rate	7.480 / 190	5.906 / 150	4.330 / 110	2.362 / 60	1.969 / 50	7.480 / 190	1.969 / 50
	Step Feed	0.1XD	0.1XD	0.1XD	0.1XD	0.1XD	0.1XD	0.1XD
~ø.60 - 1.00 mm	RPM	23,900	15,900	12,700	8,000	5,600	19,100	5,600
	Feed Rate	14.173 / 360	9.449 / 240	3.543 / 90	3.937 / 100	2.362 / 60	11.417 / 290	3.150 / 80
	Step Feed	0.2XD - .5XD*	0.2XD - .5XD*	0.2XD - .5XD*	0.1XD	0.1XD	0.2XD - .5XD*	0.1XD

* Step feed is recommended for drilling of holes deeper than 3XD



DLC Coated Drills NHGS TYPE

DLC Coated Drills



Internal Coolant Supply (NHGS Type)



■ Diameter ø3.0 to ø8.0mm

Diameter øD _c (mm)	Shank øD _s (mm)	Cat. No.	3D Type		5D Type		10D Type	
			Stock	Dimensions	Stock	Dimensions	Stock	Dimensions
		3, 5, 10	3	L L	5	L L	10	L L
3.0	3.0	MDW0300NHGS	★	68 17.5	★	78 28	★	92 42
3.1		MDW0310NHGS			★			
3.2		MDW0320NHGS	★		★		★	
3.3	4.0	MDW0330NHGS	★	72 20	★	86 32		106 49
3.4		MDW0340NHGS			★		★	
3.5		MDW0350NHGS	★		★		★	
3.6		MDW0360NHGS			★		★	
3.65		MDW0365NHGS	★		★			
3.66		MDW0366NHGS			★			
3.7	4.0	MDW0370NHGS		72 22.5	★	86 36		106 56
3.8		MDW0380NHGS			★			
3.9		MDW0390NHGS			★		★	
4.0		MDW0400NHGS	★		★		★	
4.1		MDW0410NHGS	★		★			
4.2		MDW0420NHGS	★		★			
4.3	5.0	MDW0430NHGS		80 25	★	98 40		124 63
4.4		MDW0440NHGS			★			
4.5		MDW0450NHGS	★		★		★	
4.6		MDW0460NHGS	★		★			
4.7		MDW0470NHGS			★			
4.8	5.0	MDW0480NHGS		80 27.5	★	98 44		124 70
4.9		MDW0490NHGS			★		★	
5.0		MDW0500NHGS	★		★		★	
5.1		MDW0510NHGS			★		★	
5.2		MDW0520NHGS	★		★			
5.3	6.0	MDW0530NHGS	★	82 27.5	★	100 44		136 77
5.4		MDW0540NHGS			★			
5.5		MDW0550NHGS	★		★		★	
5.6		MDW0560NHGS			★			
5.7		MDW0570NHGS			★			
5.8	6.0	MDW0580NHGS		82 30	★	100 48		136 84
5.9		MDW0590NHGS	★		★			
6.0		MDW0600NHGS	★		★		★	
6.1		MDW0610NHGS			★		★	
6.2		MDW0620NHGS			★			
6.3	7.0	MDW0630NHGS		88 32.5	★	109 52		151 91
6.4		MDW0640NHGS			★			
6.5		MDW0650NHGS	★		★		★	
6.6		MDW0660NHGS			★			
6.7		MDW0670NHGS	★		★		★	
6.8	7.0	MDW0680NHGS	★	88 35	★	109 56		151 98
6.9		MDW0690NHGS			★			
7.0		MDW0700NHGS	★		★		★	
7.1		MDW0710NHGS			★			
7.2		MDW0720NHGS			★		★	
7.3	8.0	MDW0730NHGS		94 37.5	★	118 60		166 105
7.35		MDW0735NHGS	★		★			
7.4		MDW0740NHGS	★		★			
7.5		MDW0750NHGS	★		★		★	
7.6		MDW0760NHGS			★			
7.7		MDW0770NHGS			★			
7.8	8.0	MDW0780NHGS	★	94 40	★	118 64		166 112
7.9		MDW0790NHGS			★			
8.0		MDW0800NHGS	★		★		★	

■ Characteristics

■ High efficiency drilling

AURORA COAT (DLC Coat) and low cutting resistance WL (Wide L) thinning drastically reduces cutting resistance.

■ Stable Drilling Performance

Special cutting edge design and WW (Wide W) margin improves hole quality.

■ Longer tool life

With AURORA COAT coupled with the cutting edge design, long and stable tool life can be achieved.

■ Deep hole drilling possible

Drills for deep hole drilling can be custom-made.
(Production range: Drill diameters: ø3.0 to ø16.0mm
Total length: Available on inquiry)

■ Comparison of Cutting Resistance (Thrust Force)

Drastic reduction in cutting resistance

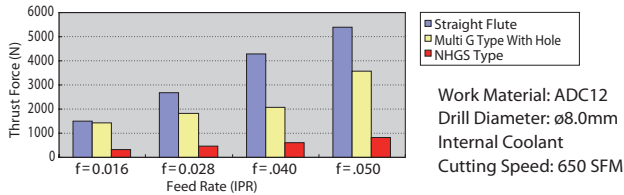

■ Application Examples

High Feed Drilling of Aluminium Alloy

Automotive Component using SP-NHGS Type

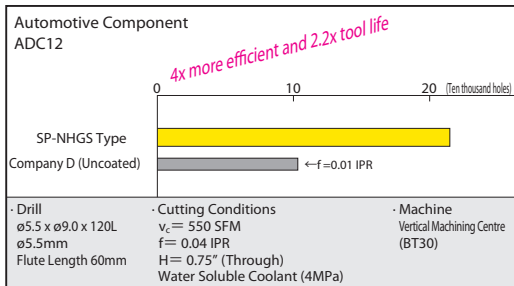

Deep Hole Drilling of Aluminium Alloy

Battery Component using SP-NHGS Type

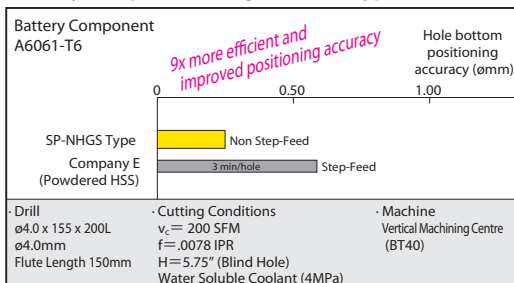

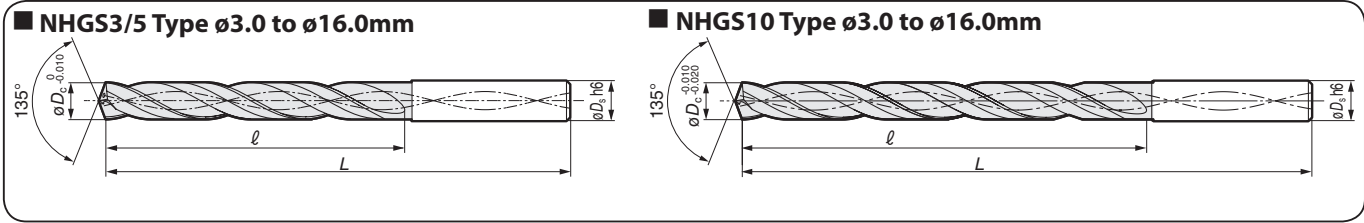

■ Diameter ø8.1 to ø13.0mm

Diameter øD _C (mm)	Shank øD _S (mm)	Cat. No.	3D Type		5D Type		10D Type	
			Stock	Dimensions	Stock	Dimensions	Stock	Dimensions
		3, 5, 10	[3]	L L	[5]	L L	[10]	L L
8.1		MDW0810NHGS	★		★			
8.2		MDW0820NHGS			★			
8.3	9.0	MDW0830NHGS		100 42.5	★	127 68		181 119
8.4		MDW0840NHGS			★			
8.5		MDW0850NHGS	★		★			★
8.6		MDW0860NHGS	★		★			
8.7		MDW0870NHGS			★			
8.8	9.0	MDW0880NHGS	★	100 45	★	127 72		181 126
8.9		MDW0890NHGS			★			
9.0		MDW0900NHGS	★		★			★
9.1		MDW0910NHGS			★			
9.2		MDW0920NHGS			★			
9.21	10.0	MDW0921NHGS	★	106 47.5	★	136 76		196 133
9.3		MDW0930NHGS			★			
9.4		MDW0940NHGS	★		★			
9.5		MDW0950NHGS	★		★			★
9.6		MDW0960NHGS			★			
9.7		MDW0970NHGS			★			
9.8	10.0	MDW0980NHGS		106 50	★	136 80	★	196 140
9.9		MDW0990NHGS			★			
10.0		MDW1000NHGS	★		★			★
10.1		MDW1010NHGS	★					
10.2		MDW1020NHGS						
10.3	11.0	MDW1030NHGS	★	116 52.5	★	149 84		215 147
10.4		MDW1040NHGS			★			
10.5		MDW1050NHGS	★		★			★
10.6		MDW1060NHGS	★		★			
10.7		MDW1070NHGS						
10.8	11.0	MDW1080NHGS		116 55		149 88		215 154
10.9		MDW1090NHGS						
11.0		MDW1100NHGS	★		★			★
11.08		MDW1108NHGS	★		★			
11.1		MDW1110NHGS	★		★			
11.2	12.0	MDW1120NHGS	★	122 57.5	★	158 92		230 161
11.3		MDW1130NHGS			★			
11.4		MDW1140NHGS	★		★			
11.5		MDW1150NHGS	★		★			★
11.6		MDW1160NHGS						
11.7		MDW1170NHGS						
11.8	12.0	MDW1180NHGS		122 60		158 96		230 168
11.9		MDW1190NHGS						
12.0		MDW1200NHGS	★		★			★
12.1		MDW1210NHGS	★		★			
12.2		MDW1220NHGS						
12.3	13.0	MDW1230NHGS	★	128 62.5	★	167 100		245 175
12.4		MDW1240NHGS						
12.5		MDW1250NHGS	★		★			★
12.6		MDW1260NHGS						
12.7		MDW1270NHGS						
12.8	13.0	MDW1280NHGS		128 65		167 104		245 182
12.9		MDW1290NHGS						
12.96		MDW1296NHGS	★		★			
13.0		MDW1300NHGS	★		★			★

■ Diameter ø13.1 to ø16.0mm

Diameter øD _C (mm)	Shank øD _S (mm)	Cat. No.	3D Type		5D Type		10D Type	
			Stock	Dimensions	Stock	Dimensions	Stock	Dimensions
		3, 5, 10	[3]	L L	[5]	L L	[10]	L L
13.1		MDW1310NHGS						
13.2		1320NHGS						
13.3	14.0	1330NHGS		134 68		176 108		260 189
13.4		1340NHGS						
13.5		1350NHGS	★		★			
13.6		MDW1360NHGS						
13.7		1370NHGS						
13.8	14.0	1380NHGS		134 70		176 112		260 196
13.9		1390NHGS						
14.0		1400NHGS	★		★			
14.1		MDW1410NHGS	★		★			
14.2		1420NHGS						
14.3	15.0	1430NHGS		140 72.5		185 116		275 203
14.4		1440NHGS						
14.5		1450NHGS	★		★			
14.6		MDW1460NHGS						
14.7		1470NHGS						
14.8		1480NHGS						
14.9	15.0	1490NHGS	★	140 75	★	185 120		275 210
14.96		1496NHGS	★		★			
15.0		1500NHGS	★		★			
15.1		MDW1510NHGS						
15.2		1520NHGS						
15.3	16.0	1530NHGS		146 77.5		194 124		290 217
15.4		1540NHGS						
15.5		1550NHGS	★		★			
15.6		MDW1560NHGS						
15.7		1570NHGS						
15.8	16.0	1580NHGS		146 80		194 128		290 224
15.9		1590NHGS						
16.0		1600NHGS	★		★			

Grade: DL1300

Please indicate 3, 5 or 10 in the when ordering.
(Example: MDW0850NHGS10)

■ Recommended Cutting Conditions

Drill Diameter øD _C (mm)	Cutting Conditions	Aluminium Casting/ Die Cast Aluminium	Wrought Aluminium Alloy
Up to ø6.0	V _c	260 - 460 - 650	260 - 400 - 650
	f	0.008 - 0.016 - 0.024	0.008 - 0.012 - 0.016
Up to ø10.0	V _c	330 - 600 - 820	330 - 500 - 820
	f	0.016 - 0.024 - 0.032	0.008 - 0.015 - 0.02
Up to ø16.0	V _c	400 - 650 - 820	400 - 590 - 820
	f	0.016 - 0.028 - .04	0.012 - 0.018 - 0.024

(V_c: Cutting Speed (m/min) f: Feed Rate (mm/rev)) Min. - Optimum - Max.





SUMITOMO

CARBIDE - CBN - DIAMOND

1-800-950-5202

www.sumicarbide.com

REPLACEABLE TIP DRILLS

Pages 489-500



Replaceable
Tip Drills

REPLACEABLE TIP DRILLS	PAGES
SMD Features & Benefits	490-491
SMDT-Drill Tips	492-493
SMDH 1.5XD Bodies & Tips.....	494-495
SMDH 3XD Bodies	496
SMDH 5XD Bodies	497
SMDH 8XD Bodies	498
SMDH 12XD Bodies.....	499
SMDH Usage & Cleaning Instructions	500

SMD FEATURES & BENEFITS

SMD Features & Benefits



SMD Bodies	Depth
S Type	1.5XD
M Type	3XD
L Type	5XD
D Type	8XD
12XD	12XD

SEE BELOW

Features & Benefits

- Available in metric and inch diameters ranging from 0.4688" - 1.6535" (42.0mm)
- Available in 3X, 5X, 8X & now **1.5X** & **12X** diameter hardened steel bodies that can accept multiple diameters
- 4 styles of drill tips to maximize performance
- New **SMDT-MFS** 180° flat edge tip now available
- SMD carbide tips have Sumitomo's patented wear resistant DEX™ coatings
- Ground serrations on back of drill tip allow for precise assembly and superior repeatability
- Drill tips are capable of being reground
- Coolant through drill bodies

SMDT Tips	Applications	Diameter Range
MTL Type 	P	Inch: 0.4688 - 1.3125 Metric: 12.00 - 42.00
MEL Type 	P K M S	Inch: 0.4688 - 1.2008 Metric: 12.00 - 30.50
MTL-C Type 	P K	Inch: 0.4688 - 1.1614 Metric: 12.00 - 29.50
MFS Type 180° flat edge	P K M S	Inch: 0.4688 - 1.1875 Metric: 12.00 - 30.00

NEW

1.5X Diameter

NEW For Rigid Applications



3X Diameter



5X Diameter



8X Diameter



12X Diameter

NEW For Deep Hole Drilling



Recommended Speeds and Feeds

Speed: v (SFM) / Feed: f (IPR)

Material	Drill Dia. (inch)	MTL	MTL	MTL	MTL	MTL-C / MEL	MEL	MEL	MEL	
		Steels	Steels	Prehard Steels	Die Steels	Ductile cast irons	Gray cast irons	Titanium	Inconel	Stainless Steels*
~ .4688	v	260 - 400	260 - 360	160 - 260	130 - 230	230 - 330	260 - 430	65 - 130	35 - 100	125 - 230
	f	.006 - .012	.006 - .012	.004 - .008	.005 - .009	.006 - .012	.008 - .012	.004 - .008	.003 - .004	.004 - .008
~ .844	v	260 - 400	260 - 360	195 - 295	130 - 230	230 - 330	260 - 430	85 - 150	50 - 115	145 - 240
	f	.006 - .014	.006 - .014	.006 - .010	.006 - .010	.006 - .014	.008 - .014	.004 - .008	.003 - .005	.004 - .009
~ 1.250	v	260 - 430	260 - 400	195 - 295	130 - 230	260 - 360	300 - 460	85 - 150	50 - 115	160 - 250
	f	.008 - .016	.008 - .014	.006 - .010	.006 - .010	.008 - .015	.008 - .018	.004 - .008	.003 - .006	.006 - .010

* For difficult to machine stainless steels (316, 302, 304, 17-4ph, etc.) adjust speeds & feeds accordingly.



Replaceable Tip Drills

MTL Type Suitable for high efficiency drilling of general steel

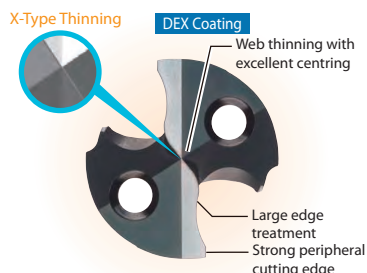

- **Excellent cutting edge strength**
Large edge treatment reduces cutting edge breakage.
- **Stable drilled hole precision**
Stable drilling performance and excellent concentricity at the start of the hole with X-type thinning.

Application Examples MTL Type

Improved tool life and efficiency

Work Material: Housing (S20C)
Drill size: For $\phi 15 \times 5D$
Cutting Conditions: $v_c=107\text{m/min}$
 $f=0.3\text{mm/rev}$
Hole Depth: $32\text{mm} \times 12$ holes

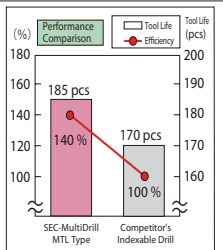

Hole diameter accuracy

High drilling accuracy even with large diameters

Work Material: SM400 (Base plate for construction machine)
Drill Size: $\phi 33 \times 5D$
Cutting Conditions: $v_c=120\text{m/min}$
 $f=0.25\text{mm/rev}$
Cutting Environment: Emulsion Type

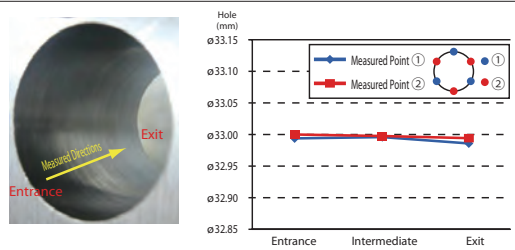

MEL Type Suitable for exotic metals such as stainless steel, soft steel, gray cast iron, and low rigidity setups.

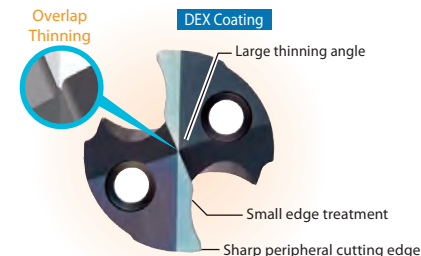

- **Excellent cutting edge design for stainless steel and soft steel**
Large thinning angle prevents breakage at the convex R-profile portion, particularly when drilling soft steel and it also reduces breakages caused by adhesion when drilling stainless steel.
- **Improved chipping resistance in cast iron**
Better edge sharpness at the peripheral edge prevents chipping around the hole openings when drilling cast iron.

Application Examples (MEL Type)

MEL (Cutting Length 15m)

SEC-MultiDrill MEL type with excellent centering, is able to drill 15m without any edge damage or visible rifle marks.

Work Material: SUS304 Drill Size: $\phi 14 \times 5D$
Cutting Conditions: $v_c=60\text{m/min}$, $f=0.15\text{m/rev}$ Coolant: Emulsion Type

Competitor's Product (Cutting Length 11m)

Breakage in Center

Competitor's indexable drill exhibited poor centering with visible rifle marks. The drill point chipped after 11m.

25% Reduction in Cutting Force (Thrust Force)

D MEL type features 25% reduced thrust compared to MTL type!

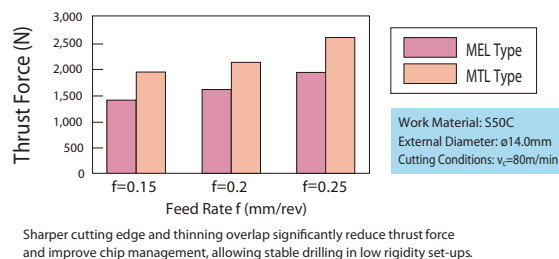

MTL-C Type Chamfers edge to eliminate break out in cast iron

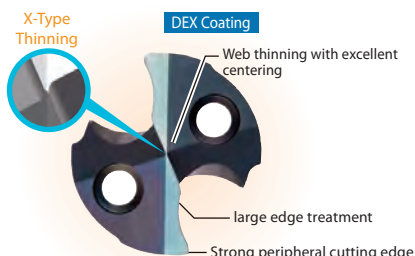

- **45° corner chamfer on diameter**
Large thinning angle prevents breakage at the convex R-profile portion, particularly when drilling soft steel and it also reduces breakages caused by adhesion when drilling stainless steel.
- **Improved chipping resistance in cast iron**
Better edge sharpness at the peripheral edge prevents chipping around the hole openings when drilling cast iron.
- **Minimizes burr and chipping at hole exit**
- **Reduces wear on corner**



Drill Tips - MTL, MEL, MTL-C Inch & Metric

■ STANDARD TIP ■ SUPER ALLOY TIP ■ CORNER BREAK TIP

1.5D 3D 5D 8D 12D

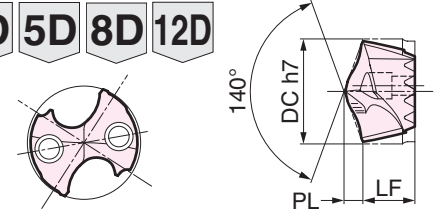

(SMDT-MTL)		(SMDT-MEL)		(SMDT-MTL-C)		øD		LF		PL		Body
Drill Tip	Stock	Drill Tip	Stock	Drill Tip	Stock	mm	in.	mm	in.	mm	in.	
SMDT04688MTL-ACX70	●	SMDT04688MEL-ACX80	●	SMDT04688MTL-C-ACX70	●	15/32	0.4688	6.9	0.272	2.2	0.087	SMDH047□
SMDT1200MTL-ACX70	●	SMDT1200MEL-ACX80	●	SMDT1200MTL-C-ACX70	●	12.0	0.4724			2.2	0.087	
SMDT1210MTL-ACX70	★	SMDT1210MEL-ACX80	★	SMDT1210MTL-C-ACX70	★	12.1	0.4764			2.2	0.087	
SMDT1220MTL-ACX70	★	SMDT1220MEL-ACX80	★	SMDT1220MTL-C-ACX70	★	12.2	0.4803			2.2	0.087	
SMDT1230MTL-ACX70	★	SMDT1230MEL-ACX80	★	SMDT1230MTL-C-ACX70	★	12.3	0.4843			2.2	0.087	
SMDT04844MTL-ACX70	●	SMDT04844MEL-ACX80	●	SMDT04844MTL-C-ACX70	●	31/64	0.4844	7.1	0.279	2.3	0.091	SMDH049□
SMDT1250MTL-ACX70	●	SMDT1250MEL-ACX80	●	SMDT1250MTL-C-ACX70	●	12.5	0.4921			2.3	0.091	
SMDT1260MTL-ACX70	★	SMDT1260MEL-ACX80	★	SMDT1260MTL-C-ACX70	★	12.6	0.4960			2.3	0.091	
SMDT05000MTL-ACX70	●	SMDT05000MEL-ACX80	●	SMDT05000MTL-C-ACX70	●	1/2	0.5000	7.3	0.287	2.3	0.091	SMDH051□
SMDT1270MTL-ACX70	★	SMDT1270MEL-ACX80	★	SMDT1270MTL-C-ACX70	★	12.7	0.5000			2.3	0.091	
SMDT1300MTL-ACX70	●	SMDT1300MEL-ACX80	●	SMDT1300MTL-C-ACX70	●	13.0	0.5118			2.4	0.095	
SMDT05156MTL-ACX70	●	SMDT05156MEL-ACX80	●	SMDT05156MTL-C-ACX70	●	33/64	0.5156			2.4	0.095	
SMDT1310MTL-ACX70	★	SMDT1310MEL-ACX80	★	SMDT1310MTL-C-ACX70	★	13.1	0.5157			2.4	0.095	
SMDT05312MTL-ACX70	●	SMDT05312MEL-ACX80	●	SMDT05312MTL-C-ACX70	●	17/32	0.5312	7.8	0.307	2.4	0.095	SMDH055□
SMDT1350MTL-ACX70	●	SMDT1350MEL-ACX80	●	SMDT1350MTL-C-ACX70	●	13.5	0.5315			2.5	0.099	
SMDT1365MTL-ACX70	●	SMDT1365MEL-ACX80	●	SMDT1365MTL-C-ACX70	●	13.65	0.5374			2.5	0.099	
SMDT05469MTL-ACX70	●	SMDT05469MEL-ACX80	●	SMDT05469MTL-C-ACX70	●	35/64	0.5469			2.5	0.099	
SMDT1400MTL-ACX70	●	SMDT1400MEL-ACX80	●	SMDT1400MTL-C-ACX70	●	14.0	0.5512			2.5	0.099	
SMDT1410MTL-ACX70	★	SMDT1410MEL-ACX80	★	SMDT1410MTL-C-ACX70	★	14.1	0.5551	8.3	0.327	2.6	0.102	SMDH059□
SMDT1420MTL-ACX70	★	SMDT1420MEL-ACX80	★	SMDT1420MTL-C-ACX70	★	14.2	0.5591			2.6	0.102	
SMDT05625MTL-ACX70	●	SMDT05625MEL-ACX80	●	SMDT05625MTL-C-ACX70	●	9/16	0.5625			2.6	0.102	
SMDT1450MTL-ACX70	●	SMDT1450MEL-ACX80	●	SMDT1450MTL-C-ACX70	●	14.5	0.5709			2.6	0.102	
SMDT05781MTL-ACX70	●	SMDT05781MEL-ACX80	●	SMDT05781MTL-C-ACX70	●	37/64	0.5781			2.7	0.106	
SMDT1500MTL-ACX70	●	SMDT1500MEL-ACX80	●	SMDT1500MTL-C-ACX70	●	15.0	0.5906	8.7	0.345	2.7	0.106	SMDH063□
SMDT05937MTL-ACX70	●	SMDT05937MEL-ACX80	●	SMDT05937MTL-C-ACX70	●	19/32	0.5938			2.7	0.106	
SMDT06094MTL-ACX70	●	SMDT06094MEL-ACX80	●	SMDT06094MTL-C-ACX70	●	39/64	0.6094			2.8	0.110	
SMDT1550MTL-ACX70	●	SMDT1550MEL-ACX80	●	SMDT1550MTL-C-ACX70	●	15.5	0.6102			2.8	0.110	
SMDT1560MTL-ACX70	★	SMDT1560MEL-ACX80	★	SMDT1560MTL-C-ACX70	★	15.6	0.6142			2.8	0.110	
SMDT1570MTL-ACX70	★	SMDT1570MEL-ACX80	★	SMDT1570MTL-C-ACX70	★	15.7	0.6181	9.2	0.362	2.9	0.114	SMDH067□
SMDT06250MTL-ACX70	●	SMDT06250MEL-ACX80	●	SMDT06250MTL-C-ACX70	●	5/8	0.6250			2.9	0.114	
SMDT1600MTL-ACX70	●	SMDT1600MEL-ACX80	●	SMDT1600MTL-C-ACX70	●	16.0	0.6300			2.9	0.114	
SMDT1608MTL-ACX70	●	SMDT1608MEL-ACX80	●	SMDT1608MTL-C-ACX70	●	16.08	0.6331			2.9	0.114	
SMDT1610MTL-ACX70	★	SMDT1610MEL-ACX80	★	SMDT1610MTL-ACX70	★	16.1	0.6339			2.9	0.114	
SMDT06406MTL-ACX70	●	SMDT06406MEL-ACX80	●	SMDT06406MTL-C-ACX70	●	41/64	0.6406	9.6	0.3780	2.9	0.114	SMDH071□
SMDT1630MTL-ACX70	●	SMDT1630MEL-ACX80	●	SMDT1630MTL-C-ACX70	●	16.3	0.6417			2.9	0.114	
SMDT1650MTL-ACX70	●	SMDT1650MEL-ACX80	●	SMDT1650MTL-C-ACX70	●	16.5	0.6496			3.0	0.118	
SMDT06562MTL-ACX70	●	SMDT06562MEL-ACX80	●	SMDT06562MTL-C-ACX70	●	21/32	0.6563			3.0	0.118	
SMDT1680MTL-ACX70	★	SMDT1680MEL-ACX70	★	SMDT1680MTL-C-ACX70	★	16.8	0.6615			3.1	0.122	
SMDT1700MTL-ACX70	●	SMDT1700MEL-ACX80	●	SMDT1700MTL-C-ACX70	●	17.0	0.6693	10.1	0.397	3.1	0.122	SMDH075□
SMDT06719MTL-ACX70	●	SMDT06719MEL-ACX80	●	SMDT06719MTL-C-ACX70	●	43/64	0.6719			3.1	0.122	
SMDT06875MTL-ACX70	●	SMDT06875MEL-ACX80	●	SMDT06875MTL-C-ACX70	●	11/16	0.6875			3.1	0.122	
SMDT1750MTL-ACX70	●	SMDT1750MEL-ACX80	●	SMDT1750MTL-C-ACX70	●	17.5	0.6890			3.1	0.122	
SMDT1760MTL-ACX70	●	SMDT1760MEL-ACX80	●	SMDT1760MTL-C-ACX70	●	17.6	0.6929			3.1	0.122	
SMDT1770MTL-ACX70	★	SMDT1770MEL-ACX80	★	SMDT1770MTL-C-ACX70	★	17.7	0.6969	10.5	0.413	3.2	0.126	SMDH079□
SMDT07031MTL-ACX70	●	SMDT07031MEL-ACX80	●	SMDT07031MTL-C-ACX70	●	45/64	0.7031			3.2	0.126	
SMDT1800MTL-ACX70	●	SMDT1800MEL-ACX80	●	SMDT1800MTL-C-ACX70	●	18.0	0.7087			3.3	0.130	
SMDT07187MTL-ACX70	●	SMDT07187MEL-ACX80	●	SMDT07187MTL-C-ACX70	●	23/32	0.7188			3.3	0.130	
SMDT1850MTL-ACX70	●	SMDT1850MEL-ACX80	●	SMDT1850MTL-C-ACX70	●	18.5	0.7283			3.4	0.134	
SMDT07344MTL-ACX70	●	SMDT07344MEL-ACX80	●	SMDT07344MTL-C-ACX70	●	47/64	0.7344	11.0	0.433	3.4	0.134	SMDH083□
SMDT1900MTL-ACX70	●	SMDT1900MEL-ACX80	●	SMDT1900MTL-C-ACX70	●	19.0	0.7480			3.5	0.138	
SMDT07500MTL-ACX70	●	SMDT07500MEL-ACX80	●	SMDT07500MTL-C-ACX70	●	3/4	0.7500			3.5	0.138	
SMDT1925MTL-ACX70	●	SMDT1925MEL-ACX80	●	SMDT1925MTL-C-ACX70	●	19.25	0.7579			3.5	0.138	
SMDT07656MTL-ACX70	●	SMDT07656MEL-ACX80	●	SMDT07656MTL-C-ACX70	●	49/64	0.7656			3.5	0.138	
SMDT1950MTL-ACX70	●	SMDT1950MEL-ACX80	●	SMDT1950MTL-C-ACX70	●	19.5	0.7677	10.5	0.413	3.5	0.138	SMDH079□
SMDT1960MTL-ACX70	★	SMDT1960MEL-ACX70	★	SMDT1960MTL-C-ACX70	★	19.6	0.7717			3.6	0.142	
SMDT07812MTL-ACX70	●	SMDT07812MEL-ACX80	●	SMDT07812MTL-C-ACX70	●	25/32	0.7813			3.6	0.142	
SMDT2000MTL-ACX70	●	SMDT2000MEL-ACX80	●	SMDT2000MTL-C-ACX70	●	20.0	0.7874			3.6	0.142	
SMDT07969MTL-ACX70	●	SMDT07969MEL-ACX80	●	SMDT07969MTL-C-ACX70	●	51/64	0.7969			3.7	0.146	
SMDT2050MTL-ACX70	●	SMDT2050MEL-ACX80	●	SMDT2050MTL-C-ACX70	●	20.5	0.8071	11.0	0.433	3.7	0.146	SMDH083□
SMDT08125MTL-ACX70	●	SMDT08125MEL-ACX80	●	SMDT08125MTL-C-ACX70	●	13/16	0.8125			3.8	0.150	
SMDT2100MTL-ACX70	●	SMDT2100MEL-ACX80	●	SMDT2100MTL-C-ACX70	●	21.0	0.8268			3.8	0.150	
SMDT2120MTL-ACX70	★	SMDT2120MEL-ACX80	★	SMDT2120MTL-C-ACX70	★	21.2	0.8346			3.9	0.154	
SMDT08281MTL-ACX70	●	SMDT08281MEL-ACX80	●	SMDT08281MTL-C-ACX70	●	53/64	0.8281			3.9	0.154	

Replaceable Tip Drills

Drill Tips - MTL, MEL, MTL-C Inch & Metric

■ STANDARD TIP ■ SUPER ALLOY TIP ■ CORNER BREAK TIP

1.5D 3D 5D 8D 12D

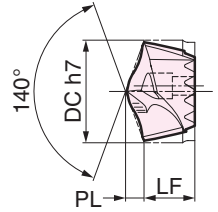

(SMDT-MTL)		(SMDT-MEL)		(SMDT-MTL-C)		øD		LF		PL		Body
Drill Tip	Stock	Drill Tip	Stock	Drill Tip	Stock	mm	in.	mm	in.	mm	in.	
SMDT08437MTL-ACX70	●	SMDT08437MEL-ACX80	●	SMDT08437MTL-C-ACX70	●	27/32	0.8438	11.0	0.433	3.9	0.154	SMDH083□
SMDT2150MTL-ACX70	●	SMDT2150MEL-ACX80	●	SMDT2150MTL-C-ACX70	●	21.5	0.8465			3.9	0.154	
SMDT08594MTL-ACX70	●	SMDT08594MEL-ACX80	●	SMDT08594MTL-C-ACX70	●	55/64	0.8594			4.0	0.158	
SMDT2200MTL-ACX70	●	SMDT2200MEL-ACX80	●	SMDT2200MTL-C-ACX70	●	22.0	0.8661			4.0	0.158	
SMDT2220MTL-ACX70	★	SMDT2220MEL-ACX70		SMDT2220MTL-C-ACX70		22.2	0.8741			4.0	0.158	
SMDT08750MTL-ACX70	●	SMDT08750MEL-ACX80	●	SMDT08750MTL-C-ACX70	●	7/8	0.8750	11.0	0.433	4.0	0.158	SMDH087□
SMDT2230MTL-ACX70	★	SMDT2230MEL-ACX70		SMDT2230MTL-C-ACX70		22.3	0.8780			4.0	0.158	
SMDT2245MTL-ACX70	●	SMDT2245MEL-ACX80	●	SMDT2245MTL-C-ACX70	●	22.45	0.8839			4.0	0.158	
SMDT2250MTL-ACX70	●	SMDT2250MEL-ACX80	●	SMDT2250MTL-C-ACX70	●	22.5	0.8858			4.1	0.162	
SMDT08906MTL-ACX70	●	SMDT08906MEL-ACX80	●	SMDT08906MTL-C-ACX70	●	57/64	0.8906			4.1	0.162	
SMDT2300MTL-ACX70	●	SMDT2300MEL-ACX80	●	SMDT2300MTL-C-ACX70	●	23.0	0.9055			4.2	0.165	
SMDT09062MTL-ACX70	●	SMDT09062MEL-ACX80	●	SMDT09062MTL-C-ACX70	●	29/32	0.9062	11.0	0.433	4.2	0.165	SMDH091□
SMDT09219MTL-ACX70	●	SMDT09219MEL-ACX80	●	SMDT09219MTL-C-ACX70	●	59/64	0.9219			4.3	0.169	
SMDT2350MTL-ACX70	●	SMDT2350MEL-ACX80	●	SMDT2350MTL-C-ACX70	●	23.5	0.9252			4.3	0.169	
SMDT09375MTL-ACX70	●	SMDT09375MEL-ACX80	●	SMDT09375MTL-C-ACX70	●	15/16	0.9375			4.4	0.173	
SMDT2400MTL-ACX70	●	SMDT2400MEL-ACX80	●	SMDT2400MTL-C-ACX70	●	24.0	0.9449			4.4	0.173	
SMDT2410MTL-ACX70	★	SMDT2410MEL-ACX80	★	SMDT2410MTL-C-ACX70		24.1	0.9488	11.0	0.433	4.4	0.173	SMDH096□
SMDT09531MTL-ACX70	●	SMDT09531MEL-ACX80	●	SMDT09531MTL-C-ACX70	●	61/64	0.9531			4.4	0.173	
SMDT2450MTL-ACX70	★	SMDT2450MEL-ACX80		SMDT2450MTL-C-ACX70		24.5	0.9646			4.5	0.177	
SMDT09687MTL-ACX70	●	SMDT09687MEL-ACX80	●	SMDT09687MTL-C-ACX70	●	31/32	0.9687			4.5	0.177	
SMDT2500MTL-ACX70	●	SMDT2500MEL-ACX80	●	SMDT2500MTL-C-ACX70	●	25.0	0.9843			4.5	0.177	
SMDT09844MTL-ACX70	●	SMDT09844MEL-ACX80	●	SMDT09844MTL-C-ACX70	●	63/64	0.9844			4.5	0.177	
SMDT10000MTL-ACX70	●	SMDT10000MEL-ACX80	●	SMDT10000MTL-C-ACX70	●	1	1.0000	11.3	0.445	4.6	0.181	SMDH100□
SMDT2550MTL-ACX70	★	SMDT2550MEL-ACX80		SMDT2550MTL-C-ACX70		25.5	1.0039			4.6	0.181	
SMDT2565MTL-ACX70	●	SMDT2565MEL-ACX80	●	SMDT2565MTL-C-ACX70	●	25.65	1.0098			4.7	0.185	
SMDT10156MTL-ACX70	●	SMDT10156MEL-ACX80	●	SMDT10156MTL-C-ACX70	●	1-1/64	1.0156			4.7	0.185	
SMDT2600MTL-ACX70	●	SMDT2600MEL-ACX80	●	SMDT2600MTL-C-ACX70	●	26.0	1.0236			4.8	0.189	
SMDT10312MTL-ACX70	●	SMDT10312MEL-ACX80	●	SMDT10312MTL-C-ACX70	●	1-1/32	1.0312	11.7	0.461	4.8	0.189	SMDH104□
SMDT2650MTL-ACX70	★	SMDT2650MEL-ACX80		SMDT2650MTL-C-ACX70		26.5	1.0433			4.8	0.189	
SMDT10469MTL-ACX70	●	SMDT10469MEL-ACX80	●	SMDT10469MTL-C-ACX70	●	1-3/64	1.0469			4.8	0.189	
SMDT10625MTL-ACX70	●	SMDT10625MEL-ACX80	●	SMDT10625MTL-C-ACX70	●	1-1/16	1.0625			4.9	0.193	
SMDT2700MTL-ACX70	●	SMDT2700MEL-ACX80	●	SMDT2700MTL-C-ACX70	●	27.0	1.0630			4.9	0.193	
SMDT10781MTL-ACX70	●	SMDT10781MEL-ACX80	●	SMDT10781MTL-C-ACX70	●	1-5/64	1.0781	12.2	0.480	4.9	0.193	SMDH107□
SMDT2750MTL-ACX70	★	SMDT2750MEL-ACX80		SMDT2750MTL-C-ACX70		27.5	1.0827			5.0	0.197	
SMDT10937MTL-ACX70	●	SMDT10937MEL-ACX80	●	SMDT10937MTL-C-ACX70	●	1-3/32	1.0937			5.0	0.197	
SMDT2800MTL-ACX70	●	SMDT2800MEL-ACX80	●	SMDT2800MTL-C-ACX70	●	28.0	1.1024			5.1	0.201	
SMDT11094MTL-ACX70	●	SMDT11094MEL-ACX80	●	SMDT11094MTL-C-ACX70	●	1-7/64	1.1094	12.6	0.496	5.1	0.201	SMDH112□
SMDT2850MTL-ACX70	●	SMDT2850MEL-ACX80	●	SMDT2850MTL-C-ACX70	●	28.5	1.1220			5.2	0.205	
SMDT11250MTL-ACX70	●	SMDT11250MEL-ACX80	●	SMDT11250MTL-C-ACX70	●	1-1/8	1.1250			5.2	0.205	
SMDT11406MTL-ACX70	●	SMDT11406MEL-ACX80	●	SMDT11406MTL-C-ACX70	●	1-9/64	1.1406			5.3	0.209	
SMDT2900MTL-ACX70	●	SMDT2900MEL-ACX80	●	SMDT2900MTL-C-ACX70	●	29.0	1.1417			5.3	0.209	
SMDT11562MTL-ACX70	●	SMDT11562MEL-ACX80	●	SMDT11562MTL-C-ACX70	●	1-5/32	1.1562	13.1	0.516	5.3	0.209	SMDH115□
SMDT2950MTL-ACX70	★	SMDT2950MEL-ACX80		SMDT2950MTL-C-ACX70		29.5	1.1614			5.4	0.213	
SMDT11719MTL-ACX70	●	SMDT11719MEL-ACX80	●	SMDT11719MTL-C-ACX70	●	1-11/64	1.1719			5.4	0.213	
SMDT3000MTL-ACX70	●	SMDT3000MEL-ACX80	●	SMDT3000MTL-C-ACX70	●	30.0	1.1811			5.5	0.217	
SMDT11875MTL-ACX70	●	SMDT11875MEL-ACX80	●	SMDT11875MTL-C-ACX70	●	1-3/16	1.1875	13.5	0.532	5.5	0.217	SMDH118□
SMDT3050MTL-ACX70	●	SMDT3050MEL-ACX80	●	SMDT3050MTL-C-ACX70	●	30.5	1.2008			5.5	0.217	
SMDT3100MTL-ACX80	●	SMDT3100MEL-ACX80	●	SMDT3100MTL-C-ACX80	●	31.0	1.2205	15.4	0.606	5.6	0.221	
SMDT12500MTL-ACX80	●	SMDT12500MEL-ACX80	●	SMDT12500MTL-C-ACX80	●	1 1/4	1.2500	15.3	0.602	5.7	0.224	SMDH1250□
SMDT3200MTL-ACX80	●	SMDT3200MEL-ACX80	●	SMDT3200MTL-C-ACX80	●	32.0	1.2598	15.2	0.599	5.8	0.228	
SMDT3300MTL-ACX80	●	SMDT3300MEL-ACX80	●	SMDT3300MTL-C-ACX80	●	33.0	1.2992	15.0	0.591	6.0	0.236	
SMDT13125MTL-ACX80	●	SMDT13125MEL-ACX80	●	SMDT13125MTL-C-ACX80	●	1 5/16	1.3125	15.0	0.591	6.1	0.240	SMDH1319□
SMDT3400MTL-ACX80	★	SMDT3400MEL-ACX80		SMDT3400MTL-C-ACX80		34.0	1.3386	16.8	0.662	6.2	0.244	SMDH350□
SMDT3500MTL-ACX80	★	SMDT3500MEL-ACX80		SMDT3500MTL-C-ACX80		35.0	1.3780	16.6	0.654	6.3	0.248	
SMDT3600MTL-ACX80	★	SMDT3600MEL-ACX80		SMDT3600MTL-C-ACX80		36.0	1.4173	16.4	0.646	6.6	0.260	SMDH365□
SMDT3700MTL-ACX80	★	SMDT3700MEL-ACX80		SMDT3700MTL-C-ACX80		37.0	1.4567	18.3	0.721	6.7	0.264	
SMDT3750MTL-ACX80	★	SMDT3750MEL-ACX80		SMDT3750MTL-C-ACX80		37.5	1.4764	18.2	0.717	6.8	0.268	SMDH380□
SMDT3800MTL-ACX80	★	SMDT3800MEL-ACX80		SMDT3800MTL-C-ACX80		38.0	1.4961	18.1	0.713	6.9	0.272	
SMDT3900MTL-ACX80	★	SMDT3900MEL-ACX80		SMDT3900MTL-C-ACX80		39.0	1.5354	17.9	0.705	7.1	0.280	SMDH395□
SMDT4000MTL-ACX80	★	SMDT4000MEL-ACX80		SMDT4000MTL-C-ACX80		40.0	1.5748	19.7	0.776	7.3	0.287	
SMDT4050MTL-ACX80	★	SMDT4050MEL-ACX80		SMDT4050MTL-C-ACX80		40.5	1.5945	19.6	0.772	7.4	0.291	SMDH410□
SMDT4100MTL-ACX80	★	SMDT4100MEL-ACX80		SMDT4100MTL-C-ACX80		41.0	1.6142	19.5	0.768	7.5	0.295	
SMDT4200MTL-ACX80	★	SMDT4200MEL-ACX80		SMDT4200MTL-C-ACX80		42.0	1.6535	19.4	0.764	7.6	0.299	SMDH425□

● = USA Stocked item ★ = Worldwide Warehouse item available in 10 business days

Note: Special diameters available upon request



MFS Type 180° ideal for drilling non-flat surfaces

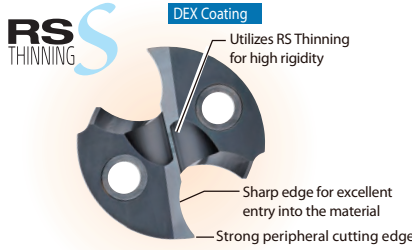

- Various drilling operations thanks to a point angle of 180°
Applicable to high-efficiency spot facing, drilling in non-flat surfaces such as inclined and cylindrical surfaces, and interrupted drilling. Also reduces burrs at the hole exit.
- Improves machining stability
Achieves high rigidity by employing RS Thinning, which ensures thick web at the bottom.

Important Notes

Application	No Guide Hole (Solid Workpiece Hole Drilling)		With Guide Hole		Flat Finishing of Hole Bottom
	Flat Surface	Non-Flat Surface	Guide Holes		
1.5D Holder	○	○	○ (Guide Hole Not Required)	○	○
3D to 12D Holder	×	×	×	○	○



Drill Tips - MFS

Inch & Metric

FLAT TIP

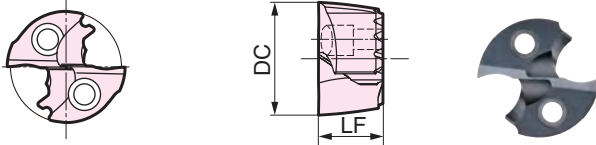

- ★ = Worldwide Warehouse item available in 10 business days
 - = USA Stocked item
- Note: Special diameters available upon request

Flat Drill Tip	Stock	øDc		LF		PL		Body
		mm	in.	mm	in.	mm	in.	
SMDT04688MFS-ACX70	●	15/32	0.4688	7.1	0.279	-	-	
SMDT1200MFS-ACX70	★	12.0mm	0.4724	7.1	0.279	-	-	SMDH047□
SMDT04844MFS-ACX70	●	31/64	0.4844	7.2	.284	-	-	
SMDT1250MFS-ACX70	●	12.5mm	0.4921	7.2	0.284	-	-	SMDH049□
SMDT05000MFS-ACX70	●	1/2	0.5000	7.5	0.295	-	-	
SMDT1300MFS-ACX70	★	13.0mm	0.5118	7.5	0.295	-	-	
SMDT05156MFS-ACX70	●	33/64	0.5156	7.5	0.295	-	-	SMDH051□
SMDT05312MFS-ACX70	●	17/32	0.5312	7.9	0.311	-	-	
SMDT1350MFS-ACX70	★	13.5mm	0.5315	7.9	0.311	-	-	
SMDT05469MFS-ACX70	●	35/64	0.5469	7.9	0.311	-	-	
SMDT1400MFS-ACX70	★	14.0mm	0.5512	7.9	0.311	-	-	SMDH055□
SMDT05625MFS-ACX70	●	9/16	0.5625	7.9	0.311	-	-	
SMDT1450MFS-ACX70	★	14.5mm	0.5709	7.9	0.311	-	-	
SMDT05781MFS-ACX70	●	37/64	0.5781	7.9	0.311	-	-	
SMDT1500MFS-ACX70	★	15.0mm	0.5906	8.3	0.327	-	-	
SMDT05938MFS-ACX70	●	19/32	0.5938	8.3	0.327	-	-	SMDH059□
SMDT06094MFS-ACX70	●	39/64	0.6094	8.3	0.327	-	-	
SMDT1550MFS-ACX70	★	15.5mm	0.6102	8.3	0.327	-	-	
SMDT06250MFS-ACX70	●	5/8	0.6250	8.8	0.347	-	-	
SMDT1600MFS-ACX70	★	16.0mm	0.6300	8.8	0.347	-	-	SMDH063□
SMDT06406MFS-ACX70	●	41/64	0.6406	8.8	0.347	-	-	
SMDT1650MFS-ACX70	★	16.5mm	0.6496	8.8	0.347	-	-	
SMDT06563MFS-ACX70	●	21/32	0.6563	9.3	0.366	-	-	
SMDT1700MFS-ACX70	★	17.0mm	0.6693	9.3	0.366	-	-	
SMDT06719MFS-ACX70	●	43/64	0.6719	9.3	0.366	-	-	SMDH067□
SMDT06875MFS-ACX70	●	11/16	0.6875	9.3	0.366	-	-	
SMDT1750MFS-ACX70	★	17.5mm	0.6890	9.3	0.366	-	-	
SMDT07031MFS-ACX70	●	45/64	0.7031	9.8	0.386	-	-	
SMDT1800MFS-ACX70	★	18.0mm	0.7087	9.8	0.386	-	-	SMDH071□
SMDT07188MFS-ACX70	●	23/32	0.7188	9.8	0.386	-	-	
SMDT1850MFS-ACX70	★	18.5mm	0.7283	9.8	0.386	-	-	
SMDT07344MFS-ACX70	●	47/64	0.7344	10.2	0.402	-	-	
SMDT1900MFS-ACX70	★	19.0mm	0.7480	10.2	0.402	-	-	
SMDT07500MFS-ACX70	●	3/4	0.7500	10.2	0.402	-	-	SMDH075□
SMDT07656MFS-ACX70	●	49/64	0.7656	10.2	0.402	-	-	
SMDT1950MFS-ACX70	★	19.5mm	0.7677	10.2	0.402	-	-	
SMDT07813MFS-ACX70	●	25/32	0.7813	10.7	0.421	-	-	
SMDT2000MFS-ACX70	★	20.0mm	0.7874	10.7	0.421	-	-	SMDH079□
SMDT07969MFS-ACX70	●	51/64	0.7969	10.7	0.421	-	-	
SMDT2050MFS-ACX70	★	20.5mm	0.8071	10.7	0.421	-	-	

Flat Drill Tip	Stock	øDc		LF		PL		Body
		mm	in.	mm	in.	mm	in.	
SMDT08125MFS-ACX70	●	13/16	0.8125	10.7	0.421	-	-	
SMDT2100MFS-ACX70	★	21.0mm	0.8268	11.2	0.441	-	-	SMDH083□
SMDT08281MFS-ACX70	●	53/64	0.8281	11.2	0.441	-	-	
SMDT08438MFS-ACX70	●	27/32	0.8438	11.2	0.441	-	-	
SMDT2150MFS-ACX70	★	21.5mm	0.8465	11.2	0.441	-	-	
SMDT08594MFS-ACX70	●	55/64	0.8594	11.2	0.441	-	-	
SMDT2200MFS-ACX70	★	22.0mm	0.8661	11.2	0.441	-	-	
SMDT08750MFS-ACX70	●	7/8	0.8750	11.2	0.441	-	-	SMDH087□
SMDT2250MFS-ACX70	★	22.5mm	0.8858	11.2	0.441	-	-	
SMDT08906MFS-ACX70	●	57/64	0.8906	11.2	0.441	-	-	
SMDT2300MFS-ACX70	★	23.0mm	0.9055	11.2	0.441	-	-	
SMDT09062MFS-ACX70	●	29/32	0.9062	11.2	0.441	-	-	SMDH091□
SMDT09219MFS-ACX70	●	59/64	0.9219	11.2	0.441	-	-	
SMDT2350MFS-ACX70	★	23.5mm	0.9252	11.2	0.441	-	-	
SMDT09375MFS-ACX70	●	15/16	0.9375	11.3	0.445	-	-	
SMDT2400MFS-ACX70	★	24.0mm	0.9449	11.3	0.445	-	-	
SMDT09531MFS-ACX70	●	61/64	0.9531	11.3	0.445	-	-	SMDH096□
SMDT2450MFS-ACX70	★	24.5mm	0.9646	11.3	0.445	-	-	
SMDT09687MFS-ACX70	●	31/32	0.9687	11.3	0.445	-	-	
SMDT2500MFS-ACX70	★	25.0mm	0.9843	11.7	0.461	-	-	
SMDT09844MFS-ACX70	●	63/64	0.9844	11.7	0.461	-	-	
SMDT10000MFS-ACX70	●	1	1.0000	11.7	0.461	-	-	SMDH100□
SMDT2550MFS-ACX70	★	25.5mm	1.0039	11.7	0.461	-	-	
SMDT10156MFS-ACX70	●	1 1/64	1.0156	11.7	0.461	-	-	
SMDT2600MFS-ACX70	★	26.0mm	1.0236	12.2	0.480	-	-	
SMDT10312MFS-ACX70	●	1 1/32	1.0312	12.2	0.480	-	-	SMDH104□
SMDT2650MFS-ACX70	★	26.5mm	1.0433	12.2	0.480	-	-	
SMDT10469MFS-ACX70	●	1 3/64	1.0469	12.2	0.480	-	-	
SMDT10625MFS-ACX70	●	1 1/16	1.0625	12.7	0.500	-	-	
SMDT2700MFS-ACX70	★	27.0mm	1.0630	12.7	0.500	-	-	
SMDT10781MFS-ACX70	●	1 5/64	1.0781	12.7	0.500	-	-	SMDH107□
SMDT2750MFS-ACX70	★	27.5mm	1.0827	12.7	0.500	-	-	
SMDT10937MFS-ACX70	●	1 3/32	1.0937	12.7	0.500	-	-	
SMDT2800MFS-ACX70	★	28.0mm	1.1024	13.2	0.520	-	-	
SMDT11094MFS-ACX70	●	1 7/64	1.1094	13.2	0.520	-	-	SMDH112□
SMDT2850MFS-ACX70	★	28.5mm	1.1220	13.2	0.520	-	-	
SMDT11250MFS-ACX70	●	1 1/8	1.1250	13.2	0.520	-	-	
SMDT11406MFS-ACX70	●	1 9/64	1.1406	13.2	0.520	-	-	
SMDT2900MFS-ACX70	★	29.0mm	1.1417	13.6	0.536	-	-	
SMDT11562MFS-ACX70	●	1 5/32	1.1562	13.6	0.536	-	-	SMDH115□
SMDT2950MFS-ACX70	★	29.5mm	1.1614	13.6	0.536	-	-	
SMDT11719MFS-ACX70	●	1 11/64	1.1719	13.6	0.536	-	-	
SMDT3000MFS-ACX70	★	30.0mm	1.1811	14.1	0.555	-	-	SMDH118□
SMDT11875MFS-ACX70	●	1 3/16	1.1875	14.1	0.555	-	-	



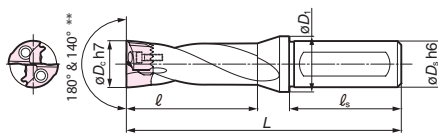

**1.5xD Drills fit all SMDT style tips (180° & 140°)



■ SMD INCH BODIES (1.5X Diameter)

*1.5xD inch bodies have cylindrical shanks

Body No.	Stock	Drill Tip Diameter (inch / mm)		ϕD_2	ϕD_1	L	ℓ_1 Max Depth	ℓ_3	Screw	Wrench
SMDH047S	●	0.4688 - 0.4917	12.00 - 12.49	0.625	0.7874	3.4843	1.0039	1.875	BXD02208IP	TRDR08IP
SMDH049S	●	0.4921 - 0.5114	12.50 - 12.99	0.625	0.7874	3.4961	1.0157	1.875	BXD02208IP	TRDR08IP
SMDH051S	●	0.5118 - 0.5311	13.00 - 13.49	0.625	0.7874	3.5433	1.0630	1.875	BXD02208IP	TRDR08IP
SMDH055S	●	0.5315 - 0.5709	13.50 - 14.50	0.750	0.7874	3.6969	1.1929	2.000	BXD02208IP	TRDR08IP
SMDH059S	●	0.5713 - 0.6102	14.51 - 15.50	0.750	0.9843	3.8307	1.2717	2.000	BXD02208IP	TRDR08IP
SMDH063S	●	0.6106 - 0.6496	15.51 - 16.50	0.750	0.9843	3.9331	1.3740	2.000	BXD02509IP	TRDR10IP
SMDH067S	●	0.6500 - 0.6890	16.51 - 17.50	0.750	0.9843	3.9921	1.4331	2.000	BXD02509IP	TRDR10IP
SMDH071S	●	0.6894 - 0.7283	17.51 - 18.50	0.750	0.9843	4.0945	1.5354	2.000	BXD02509IP	TRDR10IP
SMDH075S	●	0.7287 - 0.7677	18.51 - 19.50	1.000	1.1811	4.3858	1.5906	2.250	BXD03011IP	TRDR15IP
SMDH079S	●	0.7681 - 0.8070	19.51 - 20.50	1.000	1.1811	4.4882	1.6929	2.250	BXD03011IP	TRDR15IP
SMDH083S	●	0.8074 - 0.8465	20.51 - 21.50	1.000	1.1811	4.5472	1.7520	2.250	BXD03011IP	TRDR15IP
SMDH087S	●	0.8469 - 0.8976	21.51 - 22.80	1.000	1.1811	4.6102	1.8150	2.250	BXD03512IP	TRDR15IP
SMDH091S	●	0.8980 - 0.9370	22.81 - 23.80	1.000	1.1811	4.6457	1.8504	2.250	BXD03512IP	TRDR15IP
SMDH096S	●	0.9374 - 0.9764	23.81 - 24.80	1.000	1.4567	4.8937	1.9409	2.250	BXD03512IP	TRDR15IP
SMDH100S	●	0.9768 - 1.0157	24.81 - 25.80	1.250	1.4567	4.9094	1.9567	2.375	BXD04014IP	TRDR20IP
SMDH104S	●	1.0161 - 1.0551	25.81 - 26.80	1.250	1.4567	5.0118	2.0591	2.375	BXD04014IP	TRDR20IP
SMDH107S	●	1.0555 - 1.0945	26.81 - 27.80	1.250	1.4567	5.0315	2.0787	2.375	BXD04014IP	TRDR20IP
SMDH112S	●	1.0949 - 1.1339	27.81 - 28.80	1.250	1.4567	5.0945	2.1417	2.375	BXD04515IP	TRDR25IP
SMDH115S	●	1.1343 - 1.1732	28.81 - 29.80	1.250	1.4567	5.1496	2.1969	2.375	BXD04515IP	TRDR25IP
SMDH118S	●	1.1736 - 1.2125	29.81 - 30.80	1.250	1.4567	5.2520	2.2992	2.375	BXD04515IP	TRDR25IP

■ SMD METRIC BODIES (1.5X Diameter)

*1.5xD metric bodies have set screw flat on shanks

Body No.	Stock	Drill Tip Diameter (inch / mm)		ϕD_2	ϕD_1	L	ℓ_1 Max Depth	ℓ_3	Screw	Wrench
SMDH120S	★	0.4688 - 0.4917	12.00 - 12.49	16.0	20.0	88.5	25.5	48	BXD02208IP	TRDR08IP
SMDH125S	★	0.4921 - 0.5114	12.50 - 12.99	16.0	20.0	88.8	25.8	48	BXD02208IP	TRDR08IP
SMDH130S	★	0.5118 - 0.5311	13.00 - 13.49	16.0	20.0	90.0	27.0	48	BXD02208IP	TRDR08IP
SMDH140S	★	0.5315 - 0.5709	13.50 - 14.50	16.0	20.0	93.9	30.9	48	BXD02208IP	TRDR08IP
SMDH150S	★	0.5713 - 0.6102	14.51 - 15.50	20.0	25.0	97.3	32.3	50	BXD02208IP	TRDR08IP
SMDH160S	★	0.6106 - 0.6496	15.51 - 16.50	20.0	25.0	99.9	34.9	50	BXD02509IP	TRDR10IP
SMDH170S	★	0.6500 - 0.6890	16.51 - 17.50	20.0	25.0	101.4	36.4	50	BXD02509IP	TRDR10IP
SMDH180S	★	0.6894 - 0.7283	17.51 - 18.50	20.0	25.0	104.0	39.0	50	BXD02509IP	TRDR10IP
SMDH190S	★	0.7287 - 0.7677	18.51 - 19.50	25.0	30.0	111.4	40.4	56	BXD03011IP	TRDR15IP
SMDH200S	★	0.7681 - 0.8070	19.51 - 20.50	25.0	30.0	114.0	43.0	56	BXD03011IP	TRDR15IP
SMDH210S	★	0.8074 - 0.8465	20.51 - 21.50	25.0	30.0	115.5	44.5	56	BXD03011IP	TRDR15IP
SMDH220S	★	0.8469 - 0.8976	21.51 - 22.80	25.0	30.0	117.1	46.1	56	BXD03512IP	TRDR15IP
SMDH230S	★	0.8980 - 0.9370	22.81 - 23.80	25.0	30.0	118.0	47.0	56	BXD03512IP	TRDR15IP
SMDH240S	★	0.9374 - 0.9764	23.81 - 24.80	32.0	37.0	124.3	49.3	60	BXD03512IP	TRDR15IP
SMDH250S	★	0.9768 - 1.0157	24.81 - 25.80	32.0	37.0	124.7	49.7	60	BXD04014IP	TRDR20IP
SMDH260S	★	1.0161 - 1.0551	25.81 - 26.80	32.0	37.0	127.3	52.3	60	BXD04014IP	TRDR20IP
SMDH270S	★	1.0555 - 1.0945	26.81 - 27.80	32.0	37.0	127.8	52.8	60	BXD04014IP	TRDR20IP
SMDH280S	★	1.0949 - 1.1339	27.81 - 28.80	32.0	37.0	129.4	54.4	60	BXD04515IP	TRDR25IP
SMDH290S	★	1.1343 - 1.1732	28.81 - 29.80	32.0	37.0	130.8	55.8	60	BXD04515IP	TRDR25IP
SMDH300S	★	1.1736 - 1.2125	29.81 - 30.80	32.0	37.0	133.4	58.4	60	BXD04515IP	TRDR25IP

★ = Worldwide Warehouse item available in 10 business days ● = USA Stocked item

■ Recommended Speeds & Feeds - 1.5XD

Speed: v (SFM) / Feed: f (IPR)

Drill Dia.	Soft Steel	General Steel	Hardened Steel	Stainless Steel	Gray Cast Iron	Ductile Cast Iron	Aluminum Alloy
ϕD_c	Min - Optimum - Max	Min - Optimum - Max	Min - Optimum - Max	Min - Optimum - Max	Min - Optimum - Max	Min - Optimum - Max	Min - Optimum - Max
~0.6299	Vc 200 - 260 - 330 f .0039 - .0059 - .0079	160 - 230 - 300 .0039 - .0059 - .0079	130 - 200 - 260 .0019 - .0039 - .0059	130 - 200 - 260 .0019 - .0039 - .0059	160 - 230 - 300 .0039 - .0059 - .0079	160 - 215 - 260 .0039 - .0059 - .0079	330 - 500 - 650 .0098 - .012 - .014
~0.7874	Vc 200 - 260 - 330 f .0039 - .0059 - .0079	160 - 230 - 300 .0039 - .0059 - .0079	130 - 200 - 260 .0019 - .0039 - .0059	160 - 230 - 300 .0019 - .0039 - .0059	160 - 230 - 300 .0039 - .0059 - .0079	160 - 215 - 260 .0039 - .0059 - .0079	330 - 500 - 650 .012 - .014 - .016
~1.212	Vc 200 - 260 - 330 f .0059 - .0079 - .0098	160 - 230 - 300 .0059 - .0079 - .0098	130 - 200 - 260 .0039 - .0059 - .0079	160 - 230 - 300 .0019 - .0039 - .0059	160 - 230 - 300 .0059 - .0079 - .0098	160 - 215 - 260 .0059 - .0079 - .0098	330 - 500 - 650 .014 - .016 - .018

Note:

1. The recommended hole depth is 2 x drill diameter. The depth is measured from the highest point of the hole on drilling in inclined surfaces.
2. The recommended cutting conditions are those for drilling on flat horizontal surfaces.
3. Adjust the feed rate according to the inclination angle when drilling on an inclined surface.
4. Set the feed rate at 70% or lower when the inclination angle is 30° or less.
5. Set the feed rate at 50% or lower when the inclination angle is larger than 30°.
6. This product is a drilling tool. Do not use it for traversing or helical milling.



Replaceable Tip Drills

3X Diameter

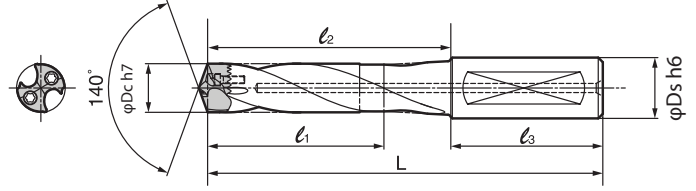

■ SMD INCH BODIES (3X Diameter)

Catalog Number	Drill Tip Diameter øDc (inch/mm)		Stock	øDs	L	l ₁ max depth	l ₂	l ₃	Screw	Wrench
SMDH047M	0.4688 - 0.4917	12.00mm - 12.49mm	●	0.625	4.141	1.734	2.266	1.875	BXD02208IP	TRDR08IP
SMDH049M	0.4921 - 0.5114	12.50mm - 12.99mm	●	0.625	4.334	1.859	2.459	1.875	BXD02208IP	TRDR08IP
SMDH051M	0.5118 - 0.5311	13.00mm - 13.49mm	●	0.625	4.334	1.859	2.459	1.875	BXD02208IP	TRDR08IP
SMDH055M	0.5315 - 0.5709	13.50mm - 14.50mm	●	0.750	4.527	2.008	2.527	2.000	BXD02208IP	TRDR08IP
SMDH059M	0.5713 - 0.6102	14.51mm - 15.50mm	●	0.750	4.921	2.126	2.921	2.000	BXD02208IP	TRDR08IP
SMDH063M	0.6106 - 0.6496	15.51mm - 16.50mm	●	0.750	5.118	2.283	3.118	2.000	BXD02509IP	TRDR10IP
SMDH067M	0.6500 - 0.6890	16.51mm - 17.50mm	●	0.750	5.315	2.401	3.315	2.000	BXD02509IP	TRDR10IP
SMDH071M	0.6894 - 0.7283	17.51mm - 18.50mm	●	0.750	5.512	2.559	3.512	2.000	BXD02509IP	TRDR10IP
SMDH075M	0.7287 - 0.7677	18.51mm - 19.50mm	●	1.000	6.102	2.677	3.852	2.250	BXD03011IP	TRDR15IP
SMDH079M	0.7681 - 0.8070	19.51mm - 20.50mm	●	1.000	6.102	2.834	3.852	2.250	BXD03011IP	TRDR15IP
SMDH083M	0.8074 - 0.8465	20.51mm - 21.50mm	●	1.000	6.102	2.953	3.852	2.250	BXD03011IP	TRDR15IP
SMDH087M	0.8469 - 0.8976	21.51mm - 22.80mm	●	1.000	6.299	3.110	4.049	2.250	BXD03512IP	TRDR15IP
SMDH091M	0.8980 - 0.9370	22.81mm - 23.80mm	●	1.000	6.299	3.228	4.049	2.250	BXD03512IP	TRDR15IP
SMDH096M	0.9374 - 0.9764	23.81mm - 24.80mm	●	1.000	6.693	3.385	4.443	2.250	BXD03512IP	TRDR15IP
SMDH100M	0.9768 - 1.0157	24.81mm - 25.80mm	●	1.250	6.693	3.465	4.318	2.375	BXD04014IP	TRDR20IP
SMDH104M	1.0161 - 1.0551	25.81mm - 26.80mm	●	1.250	6.890	3.622	4.517	2.375	BXD04014IP	TRDR20IP
SMDH107M	1.0555 - 1.0945	26.81mm - 27.80mm	●	1.250	6.890	3.701	4.517	2.375	BXD04014IP	TRDR20IP
SMDH112M	1.0949 - 1.1339	27.81mm - 28.80mm	●	1.250	7.086	3.819	4.711	2.375	BXD04515IP	TRDR25IP
SMDH115M	1.1343 - 1.1732	28.81mm - 29.80mm	●	1.250	7.283	3.937	4.908	2.375	BXD04515IP	TRDR25IP
SMDH118M	1.1736 - 1.2125	29.81mm - 30.80mm	●	1.250	7.283	4.094	4.908	2.375	BXD04515IP	TRDR25IP
SMDH1250M	1.2130 - 1.2598	30.81mm - 32.00mm	●	1.250	8.315	4.331	5.315	3.000	BXD04515IP	TRDR25IP
SMDH1319M	1.2602 - 1.3189	32.01mm - 33.50mm	●	1.500	8.512	4.528	5.512	3.000	BXD04515IP	TRDR25IP

■ SMD METRIC BODIES (3X Diameter)

3X Diameter Body No.	Drill Tip Diameter øDc (inch/mm)		Stock	øDs	L	l ₁ max depth	l ₂	l ₃	Screw	Wrench
SMDH120M	0.4688 - 0.4917	12.00mm - 12.49mm	★	16.0	105	44	57	48	BXD02208IP	TRDR08IP
SMDH125M	0.4921 - 0.5114	12.50mm - 12.99mm	★	16.0	105	44	57	48	BXD02208IP	TRDR08IP
SMDH130M	0.5118 - 0.5311	13.00mm - 13.49mm	★	16.0	110	47	62	48	BXD02208IP	TRDR08IP
SMDH140M	0.5315 - 0.5709	13.50mm - 14.50mm	★	16.0	116.5	52.5	68.5	48	BXD02208IP	TRDR08IP
SMDH150M	0.5713 - 0.6102	14.51mm - 15.50mm	★	20.0	126.5	55.5	76.5	50	BXD02208IP	TRDR08IP
SMDH160M	0.6106 - 0.6496	15.51mm - 16.50mm	★	20.0	131.5	59.5	81.5	50	BXD02509IP	TRDR10IP
SMDH170M	0.6500 - 0.6890	16.51mm - 17.50mm	★	20.0	136.5	62.5	86.5	50	BXD02509IP	TRDR10IP
SMDH180M	0.6894 - 0.7283	17.51mm - 18.50mm	★	20.0	141.5	66.5	91.5	50	BXD02509IP	TRDR10IP
SMDH190M	0.7287 - 0.7677	18.51mm - 19.50mm	★	25.0	156.5	69.5	100.5	56	BXD03011IP	TRDR15IP
SMDH200M	0.7681 - 0.8070	19.51mm - 20.50mm	★	25.0	156.5	73.5	100.5	56	BXD03011IP	TRDR15IP
SMDH210M	0.8074 - 0.8465	20.51mm - 21.50mm	★	25.0	156.5	76.5	100.5	56	BXD03011IP	TRDR15IP
SMDH220M	0.8469 - 0.8976	21.51mm - 22.80mm	★	25.0	161.1	80.1	105.1	56	BXD03512IP	TRDR15IP
SMDH230M	0.8980 - 0.9370	22.81mm - 23.80mm	★	25.0	160.6	82.6	104.6	56	BXD03512IP	TRDR15IP
SMDH240M	0.9374 - 0.9764	23.81mm - 24.80mm	★	32.0	170.2	86.2	110.2	60	BXD03512IP	TRDR15IP
SMDH250M	0.9768 - 1.0157	24.81mm - 25.80mm	★	32.0	170	88	110	60	BXD04014IP	TRDR20IP
SMDH260M	1.0161 - 1.0551	25.81mm - 26.80mm	★	32.0	175	92	115	60	BXD04014IP	TRDR20IP
SMDH270M	1.0555 - 1.0945	26.81mm - 27.80mm	★	32.0	175	94	115	60	BXD04014IP	TRDR20IP
SMDH280M	1.0949 - 1.1339	27.81mm - 28.80mm	★	32.0	180	97	120	60	BXD04515IP	TRDR25IP
SMDH290M	1.1343 - 1.1732	28.81mm - 29.80mm	★	32.0	180	100	120	60	BXD04515IP	TRDR25IP
SMDH300M	1.1736 - 1.2125	29.81mm - 30.80mm	★	32.0	185	104	125	60	BXD04515IP	TRDR25IP
SMDH320M	1.2130 - 1.2598	30.81mm - 32.00mm	★	32.0	195	97.9	135	60	BXD04515IP	TRDR25IP
SMDH335M	1.2602 - 1.3189	32.01mm - 33.50mm	★	32.0	200	103.3	140	60	BXD04515IP	TRDR25IP
SMDH350M	1.3193 - 1.3780	33.51mm - 35.00mm	★	40.0	215	106.8	145	70	BX0515	HD040
SMDH365M	1.3783 - 1.4370	35.01mm - 36.50mm	★	40.0	220	112.3	150	70	BX0515	HD040
SMDH380M	1.4374 - 1.4961	36.51mm - 38.00mm	★	40.0	225	115.8	155	70	BX0515	HD040
SMDH395M	1.4965 - 1.5551	38.01mm - 39.50mm	★	40.0	230	121.3	160	70	BX0515	HD040
SMDH410M	1.5555 - 1.6142	39.51mm - 41.00mm	★	40.0	245	129.8	175	70	BX0515	HD040
SMDH425M	1.6146 - 1.6732	41.01mm - 42.50mm	★	40.0	250	135.3	180	70	BX0515	HD040

★ = Worldwide Warehouse item available in 10 business days ● = USA Stocked item Note: Special diameters available upon request



5X Diameter

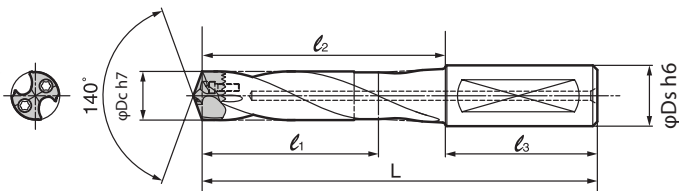

■ **SMD INCH BODIES (5X Diameter)**

Catalog Number	Drill Tip Diameter ϕDc (inch/mm)		Stock	ϕDs	L	ℓ_1 max depth	ℓ_2	ℓ_3	Screw	Wrench
SMDH047L	0.4688 - 0.4917	12.00mm - 12.49mm	●	0.625	5.109	2.672	3.234	1.875	BXD02208IP	TRDR08IP
SMDH049L	0.4921 - 0.5114	12.50mm - 12.99mm	●	0.625	5.500	2.906	3.625	1.875	BXD02208IP	TRDR08IP
SMDH051L	0.5118 - 0.5311	13.00mm - 13.49mm	●	0.625	5.500	2.906	3.625	1.875	BXD02208IP	TRDR08IP
SMDH055L	0.5315 - 0.5709	13.50mm - 14.50mm	●	0.750	5.708	3.150	3.708	2.000	BXD02208IP	TRDR08IP
SMDH059L	0.5713 - 0.6102	14.51mm - 15.50mm	●	0.750	6.102	3.346	4.102	2.000	BXD02208IP	TRDR08IP
SMDH063L	0.6106 - 0.6496	15.51mm - 16.50mm	●	0.750	6.496	3.582	4.496	2.000	BXD02509IP	TRDR10IP
SMDH067L	0.6500 - 0.6890	16.51mm - 17.50mm	●	0.750	6.693	3.780	4.693	2.000	BXD02509IP	TRDR10IP
SMDH071L	0.6894 - 0.7283	17.51mm - 18.50mm	●	0.750	6.890	4.015	4.890	2.000	BXD02509IP	TRDR10IP
SMDH075L	0.7287 - 0.7677	18.51mm - 19.50mm	●	1.000	7.480	4.212	5.230	2.250	BXD03011IP	TRDR15IP
SMDH079L	0.7681 - 0.8070	19.51mm - 20.50mm	●	1.000	7.677	4.449	5.427	2.250	BXD03011IP	TRDR15IP
SMDH083L	0.8074 - 0.8465	20.51mm - 21.50mm	●	1.000	7.677	4.645	5.427	2.250	BXD03011IP	TRDR15IP
SMDH087L	0.8469 - 0.8976	21.51mm - 22.80mm	●	1.000	7.874	4.882	5.624	2.250	BXD03512IP	TRDR15IP
SMDH091L	0.8980 - 0.9370	22.81mm - 23.80mm	●	1.000	8.268	5.078	6.018	2.250	BXD03512IP	TRDR15IP
SMDH096L	0.9374 - 0.9764	23.81mm - 24.80mm	●	1.000	8.661	5.315	6.411	2.250	BXD03512IP	TRDR15IP
SMDH100L	0.9768 - 1.0157	24.81mm - 25.80mm	●	1.250	8.858	5.512	6.483	2.375	BXD04014IP	TRDR20IP
SMDH104L	1.0161 - 1.0551	25.81mm - 26.80mm	●	1.250	9.005	5.748	6.680	2.375	BXD04014IP	TRDR20IP
SMDH107L	1.0555 - 1.0945	26.81mm - 27.80mm	●	1.250	9.252	5.945	6.877	2.375	BXD04014IP	TRDR20IP
SMDH112L	1.0949 - 1.1339	27.81mm - 28.80mm	●	1.250	9.449	6.181	7.074	2.375	BXD04515IP	TRDR25IP
SMDH115L	1.1343 - 1.1732	28.81mm - 29.80mm	●	1.250	9.645	6.378	7.270	2.375	BXD04515IP	TRDR25IP
SMDH118L	1.1736 - 1.2125	29.81mm - 30.80mm	●	1.250	10.039	6.575	7.664	2.375	BXD04515IP	TRDR25IP
SMDH1250L	1.2130 - 1.2598	30.81mm - 32.00mm	●	1.250	10.874	6.890	7.874	3.000	BXD04515IP	TRDR25IP
SMDH1319L	1.2602 - 1.3189	32.01 mm - 33.50mm	●	1.500	11.268	7.284	8.268	3.000	BXD04515IP	TRDR25IP

■ **SMD METRIC BODIES (5X Diameter)**

5X Diameter Body No.	Drill Tip Diameter ϕDc (inch/mm)		Stock	ϕDs	L	ℓ_1 max depth	ℓ_2	ℓ_3	Screw	Wrench
SMDH120L	0.4688 - 0.4917	12.00mm - 12.49mm	★	16.0	130	69	82	48	BXD02208IP	TRDR08IP
SMDH125L	0.4921 - 0.5114	12.50mm - 12.99mm	★	16.0	130	69	82	48	BXD02208IP	TRDR08IP
SMDH130L	0.5118 - 0.5311	13.00mm - 13.49mm	★	16.0	140	74	102	48	BXD02208IP	TRDR08IP
SMDH140L	0.5315 - 0.5709	13.50mm - 14.50mm	★	16.0	146.5	81.5	98.5	48	BXD02208IP	TRDR08IP
SMDH150L	0.5713 - 0.6102	14.51mm - 15.50mm	★	20.0	156.5	86.5	106.5	50	BXD02208IP	TRDR08IP
SMDH160L	0.6106 - 0.6496	15.51mm - 16.50mm	★	20.0	166.5	92.5	116.5	50	BXD02509IP	TRDR10IP
SMDH170L	0.6500 - 0.6890	16.51mm - 17.50mm	★	20.0	171.5	97.5	121.5	50	BXD02509IP	TRDR10IP
SMDH180L	0.6894 - 0.7283	17.51mm - 18.50mm	★	20.0	176.5	103.5	126.5	50	BXD02509IP	TRDR10IP
SMDH190L	0.7287 - 0.7677	18.51mm - 19.50mm	★	25.0	191.5	108.5	135.5	56	BXD03011IP	TRDR15IP
SMDH200L	0.7681 - 0.8070	19.51mm - 20.50mm	★	25.0	196.5	114.5	140.5	56	BXD03011IP	TRDR15IP
SMDH210L	0.8074 - 0.8465	20.51mm - 21.50mm	★	25.0	196.5	119.5	140.5	56	BXD03011IP	TRDR15IP
SMDH220L	0.8469 - 0.8976	21.51mm - 22.80mm	★	25.0	201.1	125.1	145.4	56	BXD03512IP	TRDR15IP
SMDH230L	0.8980 - 0.9370	22.81mm - 23.80mm	★	25.0	210.6	129.6	154.6	56	BXD03512IP	TRDR15IP
SMDH240L	0.9374 - 0.9764	23.81mm - 24.80mm	★	32.0	220.2	135.2	160.2	60	BXD03512IP	TRDR15IP
SMDH250L	0.9768 - 1.0157	24.81mm - 25.80mm	★	32.0	225	140	165	60	BXD04014IP	TRDR20IP
SMDH260L	1.0161 - 1.0551	25.81mm - 26.80mm	★	32.0	230	146	170	60	BXD04014IP	TRDR20IP
SMDH270L	1.0555 - 1.0945	26.81mm - 27.80mm	★	32.0	235	151	175	60	BXD04014IP	TRDR20IP
SMDH280L	1.0949 - 1.1339	27.81mm - 28.80mm	★	32.0	240	157	180	60	BXD04515IP	TRDR25IP
SMDH290L	1.1343 - 1.1732	28.81mm - 29.80mm	★	32.0	245	162	185	60	BXD04515IP	TRDR25IP
SMDH300L	1.1736 - 1.2125	29.81mm - 30.80mm	★	32.0	255	167	195	60	BXD04515IP	TRDR25IP
SMDH320L	1.2130 - 1.2598	30.81mm - 32.00mm	★	32.0	260	163	200	60	BXD04515IP	TRDR25IP
SMDH335L	1.2602 - 1.3189	32.01 mm - 33.50mm	★	32.0	270	171.5	210	60	BXD04515IP	TRDR25IP
SMDH350L	1.3193 - 1.3780	33.51mm - 35.00mm	★	40.0	290	182	220	70	BX0515	HD040
SMDH365L	1.3783 - 1.4370	35.01mm - 36.50mm	★	40.0	295	187.5	225	70	BX0515	HD040
SMDH380L	1.4374 - 1.4961	36.51mm - 38.00mm	★	40.0	305	195.8	235	70	BX0515	HD040
SMDH395L	1.4965 - 1.5551	38.01mm - 39.50mm	★	40.0	315	206.3	245	70	BX0515	HD040
SMDH410L	1.5555 - 1.6142	39.51mm - 41.00mm	★	40.0	325	209.8	255	70	BX0515	HD040
SMDH425L	1.6146 - 1.6732	41.01mm - 42.50mm	★	40.0	335	220.3	265	70	BX0515	HD040

★ = Worldwide Warehouse item available in 10 business days ● = USA Stocked item Note: Special diameters available upon request



8X Diameter

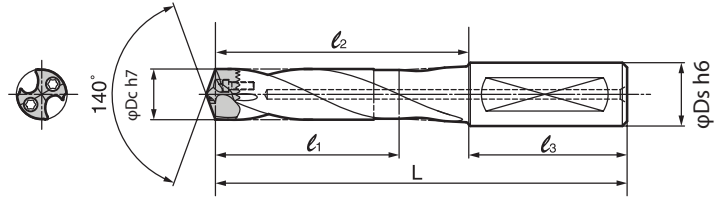

■ SMD INCH BODIES (8X Diameter)

Catalog Number	Drill Tip Diameter ϕD_c (inch/mm)		Stock	ϕD_s	L	ℓ_1 max depth	ℓ_2	ℓ_3	Screw	Wrench
SMDH055D	0.5315 - 0.5709	13.50mm - 14.50mm	●	0.750	7.480	4.961	5.480	2.000	BXD02208IP	TRDR08IP
SMDH059D	0.5713 - 0.6102	14.51mm - 15.50mm	●	0.750	7.874	5.315	5.874	2.000	BXD02208IP	TRDR08IP
SMDH063D	0.6106 - 0.6496	15.51mm - 16.50mm	●	0.750	8.307	5.630	6.307	2.000	BXD02509IP	TRDR10IP
SMDH067D	0.6500 - 0.6890	16.51mm - 17.50mm	●	0.750	8.701	5.984	6.701	2.000	BXD02509IP	TRDR10IP
SMDH071D	0.6894 - 0.7283	17.51mm - 18.50mm	●	0.750	8.898	6.299	6.898	2.000	BXD02509IP	TRDR10IP
SMDH075D	0.7287 - 0.7677	18.51mm - 19.50mm	●	1.000	9.882	6.654	7.630	2.250	BXD03011IP	TRDR15IP
SMDH079D	0.7681 - 0.8070	19.51mm - 20.50mm	●	1.000	10.276	6.969	8.024	2.250	BXD03011IP	TRDR15IP
SMDH083D	0.8074 - 0.8465	20.51mm - 21.50mm	●	1.000	10.472	7.323	8.220	2.250	BXD03011IP	TRDR15IP
SMDH087D	0.8469 - 0.8976	21.51mm - 22.80mm	●	1.000	10.669	7.638	8.417	2.250	BXD03512IP	TRDR15IP
SMDH091D	0.8980 - 0.9370	22.81mm - 23.80mm	●	1.000	11.024	7.953	8.772	2.250	BXD03512IP	TRDR15IP
SMDH096D	0.9374 - 0.9764	23.81mm - 24.80mm	●	1.000	11.614	8.268	9.362	2.250	BXD03512IP	TRDR15IP
SMDH100D	0.9768 - 1.0157	24.81mm - 25.80mm	●	1.250	11.811	8.622	9.437	2.375	BXD04014IP	TRDR20IP
SMDH104D	1.0161 - 1.0551	25.81mm - 26.80mm	●	1.250	12.205	8.937	9.830	2.375	BXD04014IP	TRDR20IP
SMDH107D	1.0555 - 1.0945	26.81mm - 27.80mm	●	1.250	12.508	9.291	10.133	2.375	BXD04014IP	TRDR20IP
SMDH112D	1.0949 - 1.1339	27.81mm - 28.80mm	●	1.250	12.795	9.606	10.420	2.375	BXD04515IP	TRDR25IP
SMDH115D	1.1343 - 1.1732	28.81mm - 29.80mm	●	1.250	13.189	9.961	10.814	2.375	BXD04515IP	TRDR25IP
SMDH118D	1.1736 - 1.2125	29.81mm - 30.80mm	●	1.250	13.503	10.276	11.128	2.375	BXD04515IP	TRDR25IP

■ SMD METRIC BODIES (8X Diameter)

8X Diameter Body No.	Drill Tip Diameter ϕD_c (inch / mm)		Stock	ϕD_s	L	ℓ_1 max depth	ℓ_2	ℓ_3	Screw	Wrench
SMDH140D	0.5315 - 0.5709	13.50mm - 14.50mm	★	16.0	191.5	124.5	143.5	48	BXD02208IP	TRDR08IP
SMDH150D	0.5713 - 0.6102	14.51mm - 15.50mm	★	20.0	201.5	133.5	151.5	50	BXD02208IP	TRDR08IP
SMDH160D	0.6106 - 0.6496	15.51mm - 16.50mm	★	20.0	211.5	141.5	161.5	50	BXD02509IP	TRDR10IP
SMDH170D	0.6500 - 0.6890	16.51mm - 17.50mm	★	20.0	221.5	150.5	171.5	50	BXD02509IP	TRDR10IP
SMDH180D	0.6894 - 0.7283	17.51mm - 18.50mm	★	20.0	226.5	158.5	176.5	50	BXD02509IP	TRDR10IP
SMDH190D	0.7287 - 0.7677	18.51mm - 19.50mm	★	25.0	251.5	167.5	195.5	56	BXD03011IP	TRDR15IP
SMDH200D	0.7681 - 0.8070	19.51mm - 20.50mm	★	25.0	261.5	175.5	205.5	56	BXD03011IP	TRDR15IP
SMDH210D	0.8074 - 0.8465	20.51mm - 21.50mm	★	25.0	266.5	184.5	210.5	56	BXD03011IP	TRDR15IP
SMDH220D	0.8469 - 0.8976	21.51mm - 22.80mm	★	25.0	271.1	192.1	215.1	56	BXD03512IP	TRDR15IP
SMDH230D	0.8980 - 0.9370	22.81mm - 23.80mm	★	25.0	280.6	200.6	224.6	56	BXD03512IP	TRDR15IP
SMDH240D	0.9374 - 0.9764	23.81mm - 24.80mm	★	32.0	295.2	208.2	235.2	60	BXD03512IP	TRDR15IP
SMDH250D	0.9768 - 1.0157	24.81mm - 25.80mm	★	32.0	300	217	240	60	BXD04014IP	TRDR20IP
SMDH260D	1.0161 - 1.0551	25.81mm - 26.80mm	★	32.0	310	225	250	60	BXD04014IP	TRDR20IP
SMDH270D	1.0555 - 1.0945	26.81mm - 27.80mm	★	32.0	320	234	260	60	BXD04014IP	TRDR20IP
SMDH280D	1.0949 - 1.1339	27.81mm - 28.80mm	★	32.0	325	242	265	60	BXD04515IP	TRDR25IP
SMDH290D	1.1343 - 1.1732	28.81mm - 29.80mm	★	32.0	335	251	275	60	BXD04515IP	TRDR25IP
SMDH300D	1.1736 - 1.2125	29.81mm - 30.80mm	★	32.0	345	259	285	60	BXD04515IP	TRDR25IP
SMDH320D	1.2130 - 1.2598	30.81mm - 32.00mm	★	32.0	355	257.9	295	60	BXD04515IP	TRDR25IP
SMDH335D	1.2602 - 1.3189	32.01 mm - 33.50mm	★	32.0	370	273.3	310	60	BXD04515IP	TRDR25IP
SMDH350D	1.3193 - 1.3780	33.51mm - 35.00mm	★	40.0	395	287	325	70	BX0515	HD040
SMDH365D	1.3783 - 1.4370	35.01mm - 36.50mm	★	40.0	405	297.3	335	70	BX0515	HD040
SMDH380D	1.4374 - 1.4961	36.51mm - 38.00mm	★	40.0	420	310.8	350	70	BX0515	HD040
SMDH395D	1.4965 - 1.5551	38.01mm - 39.50mm	★	40.0	430	321.3	360	70	BX0515	HD040
SMDH410D	1.5555 - 1.6142	39.51mm - 41.00mm	★	40.0	450	334.8	380	70	BX0515	HD040
SMDH425D	1.6146 - 1.6732	41.01mm - 42.50mm	★	40.0	460	345.3	390	70	BX0515	HD040

★ = Worldwide Warehouse item available in 10 business days

● = USA Stocked item

Note: Special diameters available upon request





12X Diameter

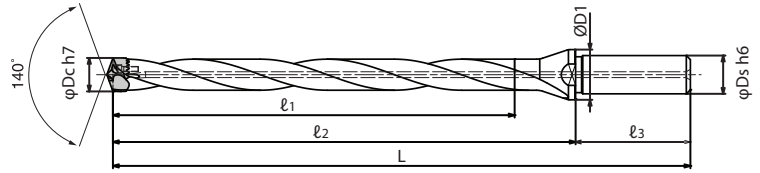

■ SMD INCH BODIES (12X Diameter)

12X Diameter Body No.	Stock	Drill Tip Diameter ϕDc (inch / mm)		ϕDs	$\phi D1$	L	ℓ_1 max depth	ℓ_2	ℓ_3	Screw	Wrench
SMDH055-12D	●	0.5315 - 0.5709	13.50 - 14.50	0.750	0.9843	9.480	6.614	7.480	2.000	BXD02208IP	TRDR08IP
SMDH059-12D	●	0.5713 - 0.6102	14.51 - 15.50	0.750	0.9843	9.965	7.087	7.965	2.000	BXD02208IP	TRDR08IP
SMDH063-12D	●	0.6106 - 0.6496	15.51 - 16.50	0.750	0.9843	10.449	7.559	8.449	2.000	BXD02509IP	TRDR10IP
SMDH067-12D	●	0.6500 - 0.6890	16.51 - 17.50	0.750	0.9843	10.937	8.031	8.937	2.000	BXD02509IP	TRDR10IP
SMDH071-12D	●	0.6894 - 0.7283	17.51 - 18.50	0.750	0.9843	11.417	8.504	9.417	2.000	BXD02509IP	TRDR10IP
SMDH075-12D	●	0.7287 - 0.7677	18.51 - 19.50	1.000	1.1811	12.154	8.976	9.904	2.250	BXD03011IP	TRDR15IP
SMDH079-12D	●	0.7681 - 0.8070	19.51 - 20.50	1.000	1.1811	12.634	9.449	10.384	2.250	BXD03011IP	TRDR15IP
SMDH083-12D	●	0.8074 - 0.8465	20.51 - 21.50	1.000	1.1811	13.118	9.921	10.868	2.250	BXD03011IP	TRDR15IP
SMDH087-12D	●	0.8469 - 0.8976	21.51 - 22.80	1.000	1.1811	13.626	10.394	11.376	2.250	BXD03512IP	TRDR15IP
SMDH091-12D	●	0.8980 - 0.9370	22.81 - 23.80	1.000	1.1811	14.165	10.866	11.915	2.250	BXD03512IP	TRDR15IP
SMDH096-12D	●	0.9374 - 0.9764	23.81 - 24.80	1.000	1.1811	14.638	11.339	12.388	2.250	BXD03512IP	TRDR15IP
SMDH100-12D	●	0.9768 - 1.0157	24.81 - 25.80	1.250	1.4567	15.232	11.811	12.857	2.375	BXD04014IP	TRDR20IP

■ SMD METRIC BODIES (12X Diameter)

12X Diameter Body No.	Stock	Drill Tip Diameter ϕDc (inch / mm)		ϕDs	$\phi D1$	L	ℓ_1 max depth	ℓ_2	ℓ_3	Screw	Wrench
SMDH140-12D	★	0.5315 - 0.5709	13.50 - 14.50	16	20	236.0	168	185.0	48	BXD02208IP	TRDR08IP
SMDH150-12D	★	0.5713 - 0.6102	14.51 - 15.50	20	25	250.3	180	197.3	50	BXD02208IP	TRDR08IP
SMDH160-12D	★	0.6106 - 0.6496	15.51 - 16.50	20	25	262.6	192	209.6	50	BXD02509IP	TRDR10IP
SMDH170-12D	★	0.6500 - 0.6890	16.51 - 17.50	20	25	275.0	204	222.0	50	BXD02509IP	TRDR10IP
SMDH180-12D	★	0.6894 - 0.7283	17.51 - 18.50	20	25	287.2	216	234.2	50	BXD02509IP	TRDR10IP
SMDH190-12D	★	0.7287 - 0.7677	18.51 - 19.50	25	30	305.6	228	246.6	56	BXD03011IP	TRDR15IP
SMDH200-12D	★	0.7681 - 0.8070	19.51 - 20.50	25	30	317.8	240	258.8	56	BXD03011IP	TRDR15IP
SMDH210-12D	★	0.8074 - 0.8465	20.51 - 21.50	25	30	330.1	252	271.1	56	BXD03011IP	TRDR15IP
SMDH220-12D	★	0.8469 - 0.8976	21.51 - 22.80	25	30	343.0	264	284.0	56	BXD03512IP	TRDR15IP
SMDH230-12D	★	0.8980 - 0.9370	22.81 - 23.80	25	30	354.8	276	295.8	56	BXD03512IP	TRDR15IP
SMDH240-12D	★	0.9374 - 0.9764	23.81 - 24.80	32	37	371.7	288	308.7	60	BXD03512IP	TRDR15IP
SMDH250-12D	★	0.9768 - 1.0157	24.81 - 25.80	32	37	383.8	300	320.8	60	BXD04014IP	TRDR20IP

★ = Worldwide Warehouse item available in 10 business days ● = USA Stocked item Note: Special diameters available upon request

■ Recommended Drilling Method

1. **Make a guide hole using the SMDH-M style (3XD) drill**

• Use a guide hole SMDH-M (3XD) style drill with the same diameter and chipbreaker as 12XD type

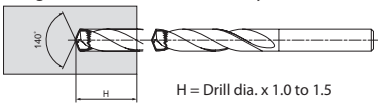

2. Feed the 12XD type through the guide hole at low rotation speed

• Rotation: 500 rpm Feed Rate: 40 - 80 ipm

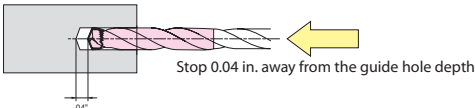

3. Increase speed until the set conditional speed is reached and start normal drilling

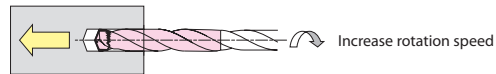

4. After drilling, rotation speed is reduced and the drill is retracted from the work material

• Rotation: 500 rpm Feed Rate: 40 - 80 ipm

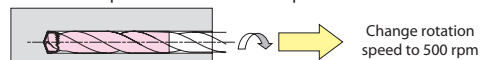

*Releasing a drill with a higher spindle speed may cause a shoulder damage by a run-out

Recommended Speeds and Feeds - 12XD Speed: v (SFM) / Feed: f (IPR)

Drill Dia. (Inch)	Soft Steel		General Steel		Hardened Steel		Stainless Steel		Gray Cast Iron		Ductile Cast Iron		Aluminum Alloy									
	Min	Optimum	Max	Min	Optimum	Max	Min	Optimum	Max	Min	Optimum	Max	Min	Optimum	Max							
~0.6299	Vc	160	230	260	160	230	260	100	160	230	130	165	200	130	200	260	130	160	230	590	650	790
	f	.0059	.0078	.014	.0059	.0078	.014	.0039	.0059	.0079	.0039	.0059	.0079	.0078	.0098	.012	.0078	.0098	.012	.014	.018	.022
~0.7874	Vc	160	230	260	160	230	260	100	160	230	130	200	230	160	230	300	130	200	260	590	650	790
	f	.0059	.0098	.014	.0059	.0098	.014	.0039	.0059	.0098	.0039	.0059	.0098	.0079	.012	.014	.0079	.012	.014	.014	.019	.024
~1.000	Vc	160	230	260	160	230	260	100	160	230	130	200	300	160	230	300	130	230	300	590	650	790
	f	.0078	.012	.014	.0078	.012	.014	.0039	.0059	.0098	.0039	.0059	.0098	.0079	.012	.016	.0098	.012	.014	.014	.019	.024



■ CLEANING INSTRUCTIONS

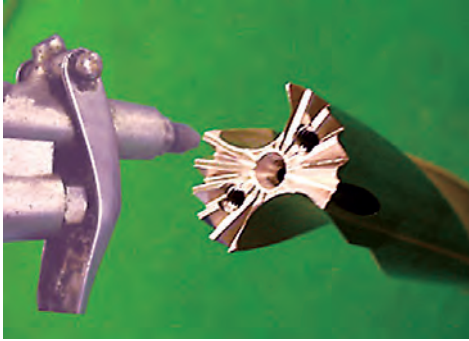

1) Air Pressure

Remove the used head and any debris from the serrated parts of the holder with an air blower.

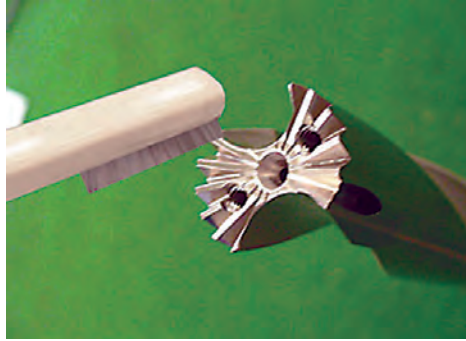

2) Brushing

Use a wire or nylon brush to remove debris left behind by air blower.

■ ATTACHING INSTRUCTIONS



- 1) Use caution when tightening the head screws. Make sure no excessive rattles.
- 2) Pre-tighten both left/ right screws until it stops lightly
- 3) Hold SMD body and a wrench in straight and tighten screws. Forcing out wrench may cause screw hole breakage.

■ Recommended Tightening Torque

Drill Head Size (in/mm)	Screw	Recommended Tightening Torque (in/lbs.)
.4688 - .6102 12.00 - 15.50	BXD02208IP	6.6 to 8.8
.6103 - .7283 15.51 - 18.50	BXD02509IP	8.2 to 11.0
.7284 - .8464 18.51 - 21.50	BXD03011IP	16.3 to 21.6
.8465 - .9763 21.51 - 24.80	BXD03512IP	24.2 to 32.9
.9764 - 1.0944 24.81 - 27.80	BXD04014IP	36.6 to 48.8
1.0945 - 1.3189 27.81 - 33.50	BXD04515IP	44.0 to 58.7

Caution!

- 1) Please wear safety gloves and glasses
- 2) Please remove SMD from any adaptor when replacing SMDT Tip
- 3) If a new tip is left outside the box for long, it may be contaminated

Serrations may contain some debris. Placing a tip without removing any foreign particles may cause loose screws and possibly lead to tip and body breakage.

INDEXABLE DRILLS

Pages 501-526



Indexable
Drills

INDEXABLE DRILLS	PAGES
WDX Drills	
WDX Features & Benefits	502
WDX Insert Selection Guide.....	503
WDX 2XD - 5XD (INCH) & 4XD Side Port	504-506
WDX 2XD - 5XD (METRIC)	507-508
WDX Inserts.....	509
Cutting Conditions	510-511
PDL/PCT	512-515
SR Reamer Series	
SR Reamer	516-526





■ Features & Benefits

- New balanced design for stable drilling
- Three chipbreakers available for superior chip control
- Four-cornered insert design for easy tool management
- **New grades:** DLC coated DL1500 inserts for aluminum and ACP100 for steel now available

Applications



Slanted surface

Half cylindrical

*Pre-drilled surface

Boring

External turning

*For pre-drilled surface: secondary OD must be at least 1/16 larger than drill diameter.

Stable Drilling

SumiDrill WDX type

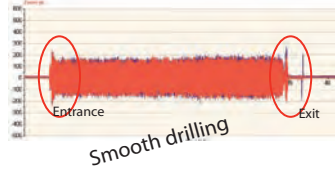

Conventional Drill

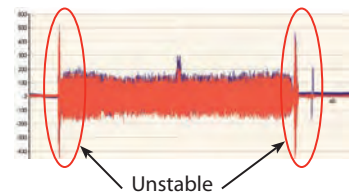

Hole Accuracy Comparison

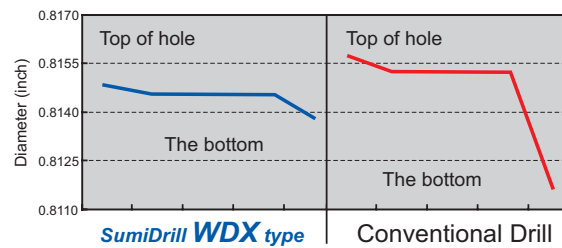

Full 4 Corner Use Insert

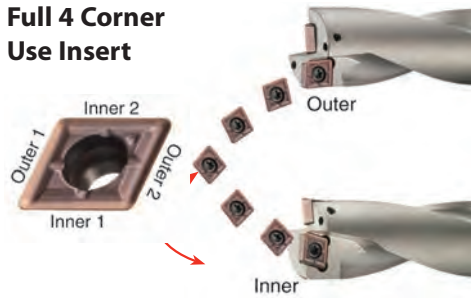

Flat Bottom Surface

SumiDrill WDX type

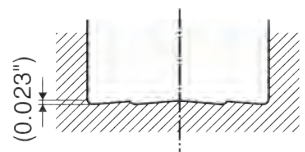

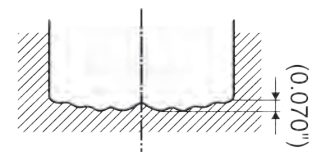

WDX0812D3S100 (0.8125")

Conventional Drill



Conventional drill (0.8125")

■ Hardware

Applicable Holders		Screw	Wrench	Wrench	Recommended Tightening Torque (N-m)	Recommended Tightening Torque (in / lbs)		
								
Inch	Metric	WDX0562D□S075 to WDX0594D□S075	WDX130D□S20 to WDX150D□S20	BFTX01604N	TRX06	0.3	2.65	
		WDX0625D□S100 to WDX0687D□S100	WDX155D□S20 to WDX180D□S25	BFTX0204N	TRX06	0.5	4.43	
		WDX0750D□S100 to WDX0875D□S100	WDX185D□S25 to WDX225D□S25	BFTY02206		TRD07	1.0	8.85
		WDX0937D□S125 to WDX1125D□S125	WDX230D□S25 to WDX285D□S32	BFTX02506N		TRD08	1.5	13.28
		WDX1187D□S125 to WDX1437D□S150	WDX290D□S32 to WDX360D□S40	BFTX03584		TRD15	3.5	30.98
		WDX1500D□S150 to WDX1750D□S150	WDX370D□S40 to WDX450D□S40	BFTX0511N		TRD20	5.0	44.25
		WDX1812D□S150 to WDX2625D□S150	WDX460D□S40 to WDX680D□S40	BFTX0615N		TRD25	5.0	44.25



Insert Selection – WDX Type Insert Series Offers Wide Selection

4

Four material grades

Grade	ACP100	ACP300	ACK300	DL1500
Steel (General Machining)	○	○		
Steel (High-Speed Machining)			○	
Stainless Steel	○	○		
Cast Iron			○	
Non-Ferrous Metal				○

3

Three types of chip breakers

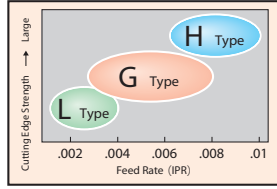

10

Ten possible combinations

Grade	ACP100	ACP300	ACK300	DL1500
L Type	○	○		
G Type		○	○	
H Type			○	

2nd Recommendation

P Steel

Low Feed, Chip Management Type

L type ACP300 ACP100

- For machining S5400, SCM415, SCM420, etc.
- In case of chip control problem, high speed with low feed rate is recommended.
- In case of vibration due to burnt chips, reduce the feed rate.

P Steel

Strong Edge Type

H type ACP300

- For interrupted machining (at entrance/exit of angled surfaces, reduce the feed rate (to approximately f 0.05) at each interruption.
- Ideal to use when the cutting edge is weakened due to machining hardened material (heat treatment)

P Steel

General Purpose

G type ACK300

For application where severe flank wear may be caused by machining general alloy or alloy steel

P Steel

Low Feed, Chip Management Type

L type ACK300

For low feed rate conditions

P Steel Improvement of chip control (low-carbon steel, etc.)

P Steel Reduction of initial chipping (caused by interrupted machining, machining hard material, etc.)

P Steel Lack of wear resistance

1st Recommendation

Breaker

General Purpose

G type

Grade

- P Steel** **M Stainless Steel** **ACP300 ACP100** For machining general steel, alloy steel or stainless steel
- K Cast Iron** **ACK300** For machining cast iron
- N Non-Ferrous Metal** **DL1500** For machining non-ferrous metals

M Stainless Steel Improvement of chip control

K Cast Iron Reduction of initial chipping (interrupted/high feed rate machining, etc.)

2nd Recommendation

M Stainless Steel

Low feed, chip management type

L type ACP300 ACP100

L Type ACP300 is ideal to solve chip evacuation problem caused by low cutting speed and low feed rate due to facility reasons.

K Cast Iron

Strong Edge Type

H type ACK300

- Similar to steel machining, H Type ACK300 is ideal for interrupted machining on angled surfaces.
- With strong edges, it is ideal for machining workpieces at high feed rate.



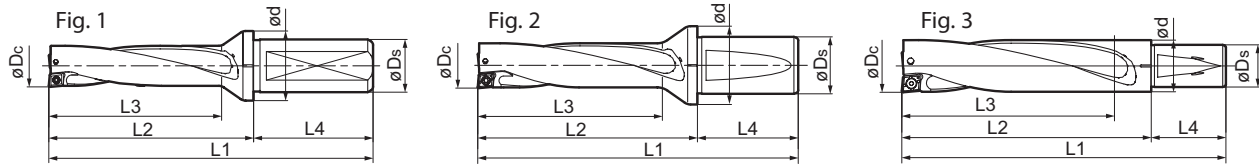

SumiDrill WDX Bodies - 2XD - INCH

Catalog Number	Stock	øDc	L1	L2	L3	ød	øDs	L4	Fig.	Screw	Wrench	Insert
WDX0562D2S075	●	0.5625	3.8330	1.8330	1.2420	1.1020	0.7500	2.0000	1	BFTX01604N	TRX06	WDX042004
WDX0594D2S075	●	0.5937	3.8960	1.8960	1.3060	1.1020	0.7500	2.0000		BFTX01604N	TRX06	WDX042004
WDX0625D2S100	●	0.6250	4.4590	1.9590	1.3680	1.2600	1.0000	2.5000		BFTX0204N	TRX06	WDX052504
WDX0656D2S100	●	0.6562	4.5210	2.0210	1.4300	1.2600	1.0000	2.5000		BFTX0204N	TRX06	WDX052504
WDX0687D2S100	●	0.6875	4.5830	2.0830	1.4920	1.2600	1.0000	2.5000		BFTX0204N	TRX06	WDX052504
WDX0750D2S100	●	0.7500	4.7090	2.2090	1.6180	1.2990	1.0000	2.5000		BFTY02206	TRD07	WDX063006
WDX0787D2S100	●	0.7870	4.7830	2.2830	1.6920	1.2990	1.0000	2.5000		BFTY02206	TRD07	WDX063006
WDX0812D2S100	●	0.8125	4.8340	2.3340	1.7430	1.2990	1.0000	2.5000		BFTY02206	TRD07	WDX063006
WDX0875D2S100	●	0.8750	4.9590	2.4590	1.8680	1.2990	1.0000	2.5000		BFTY02206	TRD07	WDX063006
WDX0937D2S125	●	0.9375	5.2020	2.7020	1.9930	1.6140	1.2500	2.5000		2	BFTX02506N	TRD08
WDX1000D2S125	●	1.0000	5.3270	2.8270	2.1180	1.6140	1.2500	2.5000	BFTX02506N		TRD08	WDX073506
WDX1062D2S125	●	1.0625	5.9520	2.9520	2.2430	1.6140	1.2500	3.0000	BFTX02506N		TRD08	WDX073506
WDX1125D2S125	●	1.1250	6.0770	3.0770	2.3680	1.6140	1.2500	3.0000	BFTX02506N		TRD08	WDX073506
WDX1187D2S125	●	1.1875	6.3590	3.3590	2.5320	1.9680	1.2500	3.0000	BFTX03584		TRX15	WDX094008
WDX1250D2S125	●	1.2500	6.4840	3.4840	2.6570	1.9680	1.2500	3.0000	BFTX03584		TRX15	WDX094008
WDX1312D2S150	●	1.3125	6.7270	3.7270	2.7820	2.1260	1.5000	3.0000	BFTX03584		TRX15	WDX094008
WDX1375D2S150	●	1.3750	6.8520	3.8520	2.9070	2.1260	1.5000	3.0000	BFTX03584		TRX15	WDX094008
WDX1437D2S150	●	1.4375	6.9770	3.9770	3.0320	2.1260	1.5000	3.0000	BFTX03584		TRX15	WDX094008
WDX1500D2S150	●	1.5000	7.1020	4.1020	3.1570	1.9490	1.5000	3.0000	BFTX0511N		TRD20	WDX125012
WDX1562D2S150	●	1.5625	7.2260	4.2260	3.2810	1.9490	1.5000	3.0000	BFTX0511N	TRD20	WDX125012	
WDX1625D2S150	●	1.6250	7.3520	4.3520	3.4070	1.9490	1.5000	3.0000	BFTX0511N	TRD20	WDX125012	
WDX1687D2S150	●	1.6875	7.4780	4.4780	3.5330	1.9490	1.5000	3.0000	3	BFTX0511N	TRD20	WDX125012
WDX1750D2S150	●	1.7500	7.6020	4.6020	3.6570	1.9490	1.5000	3.0000		BFTX0511N	TRD20	WDX125012
WDX1812D2S150	●	1.8125	7.7280	4.7280	3.7830	1.9490	1.5000	3.0000		BFTX0615N	TRD25	WDX156012
WDX1875D2S150	●	1.8750	7.8520	4.8520	3.9070	1.9490	1.5000	3.0000		BFTX0615N	TRD25	WDX156012
WDX1937D2S150	●	1.9375	7.9780	4.9780	4.0330	1.9490	1.5000	3.0000		BFTX0615N	TRD25	WDX156012
WDX2000D2S150	●	2.0000	8.1020	5.1020	4.1570	1.9490	1.5000	3.0000		BFTX0615N	TRD25	WDX156012
WDX2125D2S150	●	2.1250	8.3520	5.3520	4.4070	1.9490	1.5000	3.0000		BFTX0615N	TRD25	WDX156012
WDX2250D2S150	●	2.2500	9.0750	6.0750	4.8150	2.1730	1.5000	3.0000		BFTX0615N	TRD25	WDX186012
WDX2375D2S150	●	2.3750	9.3270	6.3270	5.0670	2.2950	1.5000	3.0000		BFTX0615N	TRD25	WDX186012
WDX2500D2S150	●	2.5000	9.5750	6.5750	5.3150	2.4210	1.5000	3.0000		BFTX0615N	TRD25	WDX186012
WDX2625D2S150	●	2.6250	9.8270	6.8270	5.5670	2.5470	1.5000	3.0000	BFTX0615N	TRD25	WDX186012	

● = USA Stocked item

SumiDrill WDX Bodies - 3XD - INCH

Catalog Number	Stock	øDc	L1	L2	L3	ød	øDs	L4	Fig.	Screw	Wrench	Insert
WDX0562D3S075	●	0.5625	4.3950	2.3950	1.8040	1.1020	0.7500	2.0000	1	BFTX01604N	TRX06	WDX042004
WDX0594D3S075	●	0.5937	4.4910	2.4910	1.9000	1.1020	0.7500	2.0000		BFTX01604N	TRX06	WDX042004
WDX0625D3S100	●	0.6250	5.0840	2.5840	1.9930	1.2600	1.0000	2.5000		BFTX0204N	TRX06	WDX052504
WDX0656D3S100	●	0.6562	5.1770	2.6770	2.0860	1.2600	1.0000	2.5000		BFTX0204N	TRX06	WDX052504
WDX0687D3S100	●	0.6875	5.2700	2.7700	2.1790	1.2600	1.0000	2.5000		BFTX0204N	TRX06	WDX052504
WDX0750D3S100	●	0.7500	5.4590	2.9590	2.3680	1.2990	1.0000	2.5000		BFTY02206	TRD07	WDX063006
WDX0787D3S100	●	0.7870	5.5700	3.0700	2.4790	1.2990	1.0000	2.5000		BFTY02206	TRD07	WDX063006
WDX0812D3S100	●	0.8125	5.6460	3.1460	2.5560	1.2990	1.0000	2.5000		BFTY02206	TRD07	WDX063006
WDX0875D3S100	●	0.8750	5.8340	3.3340	2.7430	1.2990	1.0000	2.5000		BFTY02206	TRD07	WDX063006
WDX0937D3S125	●	0.9375	6.1390	3.6390	2.9310	1.6140	1.2500	2.5000		2	BFTX02506N	TRD08
WDX1000D3S125	●	1.0000	6.3270	3.8270	3.1180	1.6140	1.2500	2.5000	BFTX02506N		TRD08	WDX073506
WDX1062D3S125	●	1.0625	7.0140	4.0140	3.3060	1.6140	1.2500	3.0000	BFTX02506N		TRD08	WDX073506
WDX1125D3S125	●	1.1250	7.2020	4.2020	3.4930	1.6140	1.2500	3.0000	BFTX02506N		TRD08	WDX073506
WDX1187D3S125	●	1.1875	7.5470	4.5470	3.7200	1.9680	1.2500	3.0000	BFTX03584		TRX15	WDX094008
WDX1250D3S125	●	1.2500	7.7340	4.7340	3.9070	1.9680	1.2500	3.0000	BFTX03584		TRX15	WDX094008
WDX1312D3S150	●	1.3125	8.0400	5.0400	4.0950	2.1260	1.5000	3.0000	BFTX03584		TRX15	WDX094008
WDX1375D3S150	●	1.3750	8.2270	5.2270	4.2820	2.1260	1.5000	3.0000	BFTX03584		TRX15	WDX094008
WDX1437D3S150	●	1.4375	8.4150	5.4150	4.4700	2.1260	1.5000	3.0000	BFTX03584		TRX15	WDX094008
WDX1500D3S150	●	1.5000	8.8780	5.8780	4.6970	1.9490	1.5000	3.0000	BFTX0511N		TRD20	WDX125012
WDX1562D3S150	●	1.5625	9.0640	6.0640	4.8830	1.9490	1.5000	3.0000	BFTX0511N	TRD20	WDX125012	
WDX1625D3S150	●	1.6250	9.2530	6.2530	5.0720	1.9490	1.5000	3.0000	BFTX0511N	TRD20	WDX125012	
WDX1687D3S150	●	1.6875	9.4420	6.4420	5.2610	1.9490	1.5000	3.0000	3	BFTX0511N	TRD20	WDX125012
WDX1750D3S150	●	1.7500	9.6280	6.6280	5.4470	1.9490	1.5000	3.0000		BFTX0511N	TRD20	WDX125012
WDX1812D3S150	●	1.8125	9.8170	6.8170	5.6360	1.9490	1.5000	3.0000		BFTX0615N	TRD25	WDX156012
WDX1875D3S150	●	1.8750	10.0030	7.0030	5.8820	1.9490	1.5000	3.0000		BFTX0615N	TRD25	WDX156012
WDX1937D3S150	●	1.9375	10.1920	7.1920	6.0110	1.9490	1.5000	3.0000		BFTX0615N	TRD25	WDX156012
WDX2000D3S150	●	2.0000	10.3780	7.3780	6.1970	1.9490	1.5000	3.0000		BFTX0615N	TRD25	WDX156012
WDX2125D3S150	●	2.1250	10.7530	7.7530	6.5720	1.9490	1.5000	3.0000		BFTX0615N	TRD25	WDX156012
WDX2250D3S150	●	2.2500	11.3270	8.3270	7.0670	2.1730	1.5000	3.0000		BFTX0615N	TRD25	WDX186012
WDX2375D3S150	●	2.3750	11.7010	8.7010	7.4410	2.2950	1.5000	3.0000		BFTX0615N	TRD25	WDX186012
WDX2500D3S150	●	2.5000	12.0750	9.0750	7.8150	2.4210	1.5000	3.0000		BFTX0615N	TRD25	WDX186012
WDX2625D3S150	●	2.6250	12.4490	9.4490	8.1890	2.5470	1.5000	3.0000	BFTX0615N	TRD25	WDX186012	

● = USA Stocked item



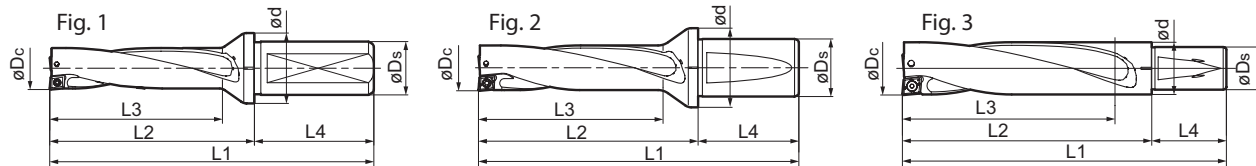

SumiDrill WDX Bodies - 4XD - INCH

Catalog Number	Stock	øDc	L1	L2	L3	ød	øDs	L4	Fig.	Screw	Wrench	Insert
WDX0562D4S075	●	0.5625	4.9570	2.9570	2.3660	1.1020	0.7500	2.0000	1	BFTX01604N	TRX06	WDXT042004
WDX0594D4S075	●	0.5937	5.0850	3.0850	2.4940	1.1020	0.7500	2.0000		BFTX01604N	TRX06	WDXT042004
WDX0625D4S100	●	0.6250	5.7090	3.2090	2.6180	1.2600	1.0000	2.5000		BFTX0204N	TRX06	WDXT052504
WDX0656D4S100	●	0.6562	5.8330	3.3330	2.7420	1.2600	1.0000	2.5000		BFTX0204N	TRX06	WDXT052504
WDX0687D4S100	●	0.6875	5.9570	3.4570	2.8660	1.2600	1.0000	2.5000		BFTX0204N	TRX06	WDXT052504
WDX0750D4S100	●	0.7500	6.2090	3.7090	3.1180	1.2990	1.0000	2.5000		BFTY02206	TRD07	WDXT063006
WDX0787D4S100	●	0.7870	6.3570	3.8570	3.2660	1.2990	1.0000	2.5000		BFTY02206	TRD07	WDXT063006
WDX0812D4S100	●	0.8125	6.4590	3.9590	3.3680	1.2990	1.0000	2.5000		BFTY02206	TRD07	WDXT063006
WDX0875D4S100	●	0.8750	6.7090	4.2090	3.6180	1.2990	1.0000	2.5000		BFTY02206	TRD07	WDXT063006
WDX0937D4S125	●	0.9375	7.0770	4.5770	3.8680	1.6140	1.2500	3.0000		BFTX02506N	TRD08	WDXT073506
WDX1000D4S125	●	1.0000	7.3270	4.8270	4.1180	1.6140	1.2500	2.5000	BFTX02506N	TRD08	WDXT073506	
WDX1062D4S125	●	1.0625	8.0770	5.0770	4.3680	1.6140	1.2500	3.0000	BFTX02506N	TRD08	WDXT073506	
WDX1125D4S125	●	1.1250	8.3270	5.3270	4.6180	1.6140	1.2500	3.0000	BFTX02506N	TRD08	WDXT073506	
WDX1187D4S125	●	1.1875	8.7340	5.7340	4.9070	1.9680	1.2500	3.0000	BFTX03584	TRX15	WDXT094008	
WDX1250D4S125	●	1.2500	8.9840	5.9840	5.1570	1.9680	1.2500	3.0000	BFTX03584	TRX15	WDXT094008	
WDX1312D4S150	●	1.3125	9.3520	6.3520	5.4070	2.1260	1.5000	3.0000	BFTX03584	TRX15	WDXT094008	
WDX1375D4S150	●	1.3750	9.6020	6.6020	5.6570	2.1260	1.5000	3.0000	BFTX03584	TRX15	WDXT094008	
WDX1437D4S150	●	1.4375	9.8520	6.8520	5.9070	2.1260	1.5000	3.0000	BFTX03584	TRX15	WDXT094008	
WDX1500D4S150	●	1.5000	10.3780	7.3780	6.1970	1.9490	1.5000	3.0000	BFTX0511N	TRD20	WDXT125012	
WDX1562D4S150	●	1.5625	10.6260	7.6260	6.4450	1.9490	1.5000	3.0000	BFTX0511N	TRD20	WDXT125012	
WDX1625D4S150	●	1.6250	10.8780	7.8780	6.6970	1.9490	1.5000	3.0000	BFTX0511N	TRD20	WDXT125012	
WDX1687D4S150	●	1.6875	11.1300	8.1300	6.9490	1.9490	1.5000	3.0000	BFTX0511N	TRD20	WDXT125012	
WDX1750D4S150	●	1.7500	11.3780	8.3780	7.1970	1.9490	1.5000	3.0000	BFTX0511N	TRD20	WDXT125012	
WDX1812D4S150	●	1.8125	11.6300	8.6300	7.4490	1.9490	1.5000	3.0000	BFTX0615N	TRD25	WDXT156012	
WDX1875D4S150	●	1.8750	11.8780	8.8780	7.6970	1.9490	1.5000	3.0000	BFTX0615N	TRD25	WDXT156012	
WDX1937D4S150	●	1.9375	12.1300	9.1300	7.9490	1.9490	1.5000	3.0000	BFTX0615N	TRD25	WDXT156012	
WDX2000D4S150	●	2.0000	12.3780	9.3780	8.1970	1.9490	1.5000	3.0000	BFTX0615N	TRD25	WDXT156012	
WDX2125D4S150	●	2.1250	12.8780	9.8780	8.6970	1.9490	1.5000	3.0000	BFTX0615N	TRD25	WDXT156012	
WDX2250D4S150	●	2.2500	13.5750	10.5750	9.3150	2.1730	1.5000	3.0000	BFTX0615N	TRD25	WDXT186012	
WDX2375D4S150	●	2.3750	14.0750	11.0750	9.8150	2.2950	1.5000	3.0000	BFTX0615N	TRD25	WDXT186012	
WDX2500D4S150	●	2.5000	14.5750	11.5750	10.3150	2.4210	1.5000	3.0000	BFTX0615N	TRD25	WDXT186012	

● = USA Stocked item

SumiDrill WDX Bodies - 5XD* - INCH

Catalog Number	Stock	øDc	L1	L2	L3	ød	øDs	L4	Fig.	Screw	Wrench	Insert	Coolant Sleeve
WDX0562D5S075	●	0.5620	5.5190	3.5190	2.9280	1.1020	0.7500	2.0000	1	BFTX01604N	TRX06	WDXT042004	SLV075
WDX0594D5S075	●	0.5940	5.6790	3.6790	3.0880	1.1020	0.7500	2.0000		BFTX01604N	TRX06	WDXT042004	
WDX0625D5S100	●	0.6250	6.3340	3.8340	3.2430	1.2600	1.0000	2.5000		BFTX0204N	TRX06	WDXT052504	SLV1000
WDX0656D5S100	●	0.6560	6.4890	3.9890	3.3980	1.2600	1.0000	2.5000		BFTX0204N	TRX06	WDXT052504	
WDX0687D5S100	●	0.6870	6.6440	4.1440	3.5530	1.2600	1.0000	2.5000		BFTX0204N	TRX06	WDXT052504	
WDX0750D5S100	●	0.7500	6.9590	4.4590	3.8680	1.2990	1.0000	2.5000		BFTY02206	TRD07	WDXT063006	
WDX0787D5S100	●	0.7870	7.1440	4.6440	4.0530	1.2990	1.0000	2.5000		BFTY02206	TRD07	WDXT063006	
WDX0812D5S100	●	0.8120	7.2690	4.7690	4.1780	1.2990	1.0000	2.5000		BFTY02206	TRD07	WDXT063006	
WDX0875D5S100	●	0.8750	7.5840	5.0840	4.4930	1.2990	1.0000	2.5000		BFTY02206	TRD07	WDXT063006	
WDX0937D5S125	●	0.9370	8.0120	5.5120	4.8030	1.6140	1.2500	2.5000		BFTX02506N	TRD08	WDXT073506	
WDX1000D5S125	●	1.0000	8.3270	5.8270	5.1180	1.6140	1.2500	2.5000	BFTX02506N	TRD08	WDXT073506		
WDX1062D5S125	●	1.0620	9.1370	6.1370	5.4280	1.6140	1.2500	3.0000	BFTX02506N	TRD08	WDXT073506	SLV1250L	
WDX1125D5S125	●	1.1250	9.4520	6.4520	5.7430	1.6140	1.2500	3.0000	BFTX02506N	TRD08	WDXT073506		
WDX1187D5S125	●	1.1870	9.9200	6.9200	6.0930	1.9680	1.2500	3.0000	BFTX03584	TRX15	WDXT094008		
WDX1250D5S125	●	1.2500	10.2350	7.2350	6.4080	1.9680	1.2500	3.0000	BFTX03584	TRX15	WDXT094008		
WDX1312D5S150	●	1.3120	10.6630	7.6630	6.7180	2.1260	1.5000	3.0000	BFTX03584	TRX15	WDXT094008		
WDX1375D5S150	●	1.3750	10.9780	7.9780	7.0330	2.1260	1.5000	3.0000	BFTX03584	TRX15	WDXT094008		
WDX1437D5S150	●	1.4370	11.2880	8.2880	7.3430	2.1260	1.5000	3.0000	BFTX03584	TRX15	WDXT094008		
WDX1500D5S150	●	1.5000	11.8780	8.8780	7.6970	1.9490	1.5000	3.0000	BFTX0511N	TRD20	WDXT125012		
WDX1562D5S150	●	1.5620	12.1880	9.1880	8.0070	1.9490	1.5000	3.0000	BFTX0511N	TRD20	WDXT125012		
WDX1625D5S150	●	1.6250	12.5030	9.5030	8.3220	1.9490	1.5000	3.0000	BFTX0511N	TRD20	WDXT125012		
WDX1687D5S150	●	1.6870	12.8130	9.8130	8.6320	1.9490	1.5000	3.0000	BFTX0511N	TRD20	WDXT125012		
WDX1750D5S150	●	1.7500	13.1280	10.1280	8.9470	1.9490	1.5000	3.0000	BFTX0511N	TRD20	WDXT125012		
WDX1812D5S150	●	1.8120	13.4380	10.4380	9.2570	1.9490	1.5000	3.0000	BFTX0615N	TRD25	WDXT156012		
WDX1875D5S150	●	1.8750	13.7530	10.7530	9.5720	1.9490	1.5000	3.0000	BFTX0615N	TRD25	WDXT156012		
WDX1937D5S150	●	1.9370	14.0630	11.0630	9.8820	1.9490	1.5000	3.0000	BFTX0615N	TRD25	WDXT156012		
WDX2000D5S150	●	2.0000	14.3780	11.3780	10.1970	1.9490	1.5000	3.0000	BFTX0615N	TRD25	WDXT156012		
WDX2125D5S150	●	2.1250	15.0030	12.0030	10.8220	1.9490	1.5000	3.0000	BFTX0615N	TRD25	WDXT156012		

● = USA Stocked item

*NOTE: Coolant adapter sleeves for lathes are available upon request.

** 5XD WDX Drills have 2 coolant holes in the back of the drill and no single threaded port

see pg. 509 for Coolant Adapter Info



4XD Side Port - INCH WDX

WDX Indexable Coolant Through Drills

Sumitomo Electric Carbide, Inc. is now offering WDX-L Indexable Drill with side port coolant. Due to not all spindles being coolant-thru, the WDX-L allows for customers to use coolant through the side port.

Features & Benefits

- Diameters available in 0.5625" to 2.5000"
- WDX-L uses WDXT inserts (same as WDX style)
- Available in 4XD style

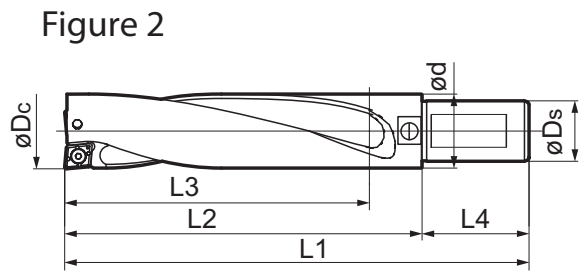
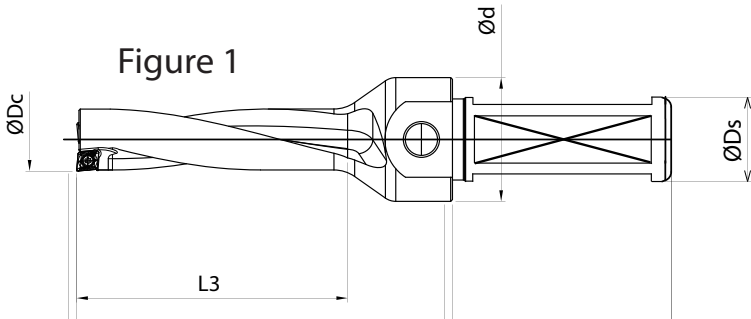

SumiDrill WDX Bodies - 4XD Side Port - INCH

Catalog Number	Stock	øDc	L1	L2	L3	ød	øDs	L4	Screw	Wrench	Insert	Pipe Plug	Fig.
WDX0562D4S100-L	●	0.5625	5.350	3.350	2.366	1.102	1.000	2.000	BFTX01604N	TRX06	WDXT042004	XP02	1
WDX0594D4S100-L	●	0.5937	5.478	3.478	2.494	1.102	1.000	2.000	BFTX01604N	TRX06	WDXT042004	XP02	
WDX0625D4S100-L	●	0.6250	6.181	3.681	2.618	1.260	1.000	2.500	BFTX0204N	TRX06	WDXT052504	XP04	
WDX0656D4S100-L	●	0.6562	6.305	3.805	2.742	1.260	1.000	2.500	BFTX0204N	TRX06	WDXT052504	XP04	
WDX0687D4S100-L	●	0.6875	6.429	3.929	2.866	1.260	1.000	2.500	BFTX0204N	TRX06	WDXT052504	XP04	
WDX0750D4S100-L	●	0.7500	6.681	4.181	3.118	1.299	1.000	2.500	BFTY02206	TRD07	WDXT063006	XP04	
WDX0787D4S100-L	●	0.7870	6.829	4.329	3.266	1.299	1.000	2.500	BFTY02206	TRD07	WDXT063006	XP04	
WDX0812D4S100-L	●	0.8125	6.931	4.431	3.368	1.299	1.000	2.500	BFTY02206	TRD07	WDXT063006	XP04	
WDX0875D4S100-L	●	0.8750	7.181	4.681	3.618	1.299	1.000	2.500	BFTY02206	TRD07	WDXT063006	XP04	
WDX0937D4S125-L	●	0.9375	7.549	5.049	3.868	1.614	1.250	2.500	BFTX02506N	TRD08	WDXT073506	XP04	
WDX1000D4S125-L	●	1.0000	7.799	5.299	4.118	1.614	1.250	2.500	BFTX02506N	TRD08	WDXT073506	XP04	
WDX1062D4S125-L	●	1.0625	8.549	5.549	4.368	1.614	1.250	3.000	BFTX02506N	TRD08	WDXT073506	XP04	
WDX1125D4S125-L	●	1.1250	8.799	5.799	4.618	1.614	1.250	3.000	BFTX02506N	TRD08	WDXT073506	XP04	
WDX1187D4S125-L	●	1.1875	9.206	6.206	4.907	1.968	1.250	3.000	BFTX03584	TRX15	WDXT094008	XP04	
WDX1250D4S125-L	●	1.2500	9.456	6.456	5.157	1.968	1.250	3.000	BFTX03584	TRX15	WDXT094008	XP04	
WDX1312D4S150-L	●	1.3125	9.824	6.824	5.407	2.126	1.500	3.000	BFTX03584	TRX15	WDXT094008	XP04	
WDX1375D4S150-L	●	1.3750	10.074	7.074	5.657	2.126	1.500	3.000	BFTX03584	TRX15	WDXT094008	XP04	
WDX1437D4S150-L	●	1.4375	10.324	7.324	5.907	2.126	1.500	3.000	BFTX03584	TRX15	WDXT094008	XP04	
WDX1500D4S150-L	●	1.5000	10.850	7.850	6.197	1.949	1.500	3.000	BFTX0511N	TRD20	WDXT125012	XP04	
WDX1562D4S150-L	●	1.5625	11.098	8.098	6.445	1.949	1.500	3.000	BFTX0511N	TRD20	WDXT125012	XP04	
WDX1625D4S150-L	●	1.6250	11.350	8.350	6.697	1.949	1.500	3.000	BFTX0511N	TRD20	WDXT125012	XP04	
WDX1687D4S150-L	●	1.6875	11.602	8.602	6.949	1.949	1.500	3.000	BFTX0511N	TRD20	WDXT125012	XP04	
WDX1750D4S150-L	●	1.7500	11.850	8.850	7.197	1.949	1.500	3.000	BFTX0511N	TRD20	WDXT125012	XP04	
WDX1812D4S150-L	●	1.8125	12.102	9.102	7.449	1.949	1.500	3.000	BFTX0615N	TRD25	WDXT156012	XP04	
WDX1875D4S150-L	●	1.8750	12.350	9.350	7.697	1.949	1.500	3.000	BFTX0615N	TRD25	WDXT156012	XP04	
WDX1937D4S150-L	●	1.9375	12.602	9.602	7.949	1.949	1.500	3.000	BFTX0615N	TRD25	WDXT156012	XP04	
WDX2000D4S150-L	●	2.0000	12.850	9.850	8.197	1.949	1.500	3.000	BFTX0615N	TRD25	WDXT156012	XP04	
WDX2125D4S150-L	●	2.1250	13.350	10.350	8.697	1.949	1.500	3.000	BFTX0615N	TRD25	WDXT156012	XP04	
WDX2250D4S150-L	●	2.2500	14.047	11.047	9.315	2.173	1.500	3.000	BFTX0615N	TRD25	WDXT186012	XP04	
WDX2375D4S150-L	●	2.3750	14.547	11.547	9.815	2.295	1.500	3.000	BFTX0615N	TRD25	WDXT186012	XP04	
WDX2500D4S150-L	●	2.5000	15.047	12.047	10.315	2.421	1.500	3.000	BFTX0615N	TRD25	WDXT186012	XP04	



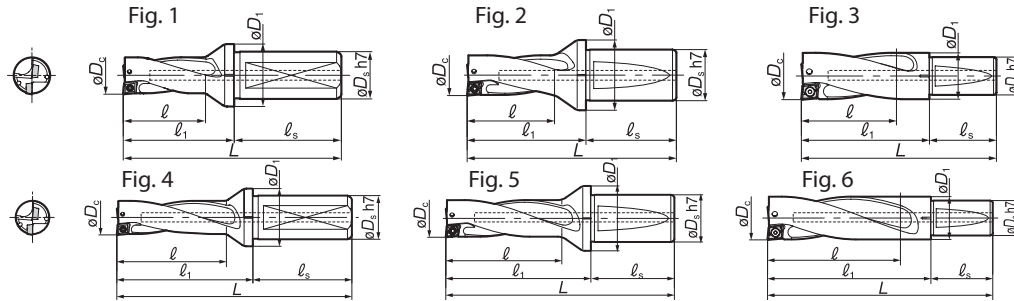

SumiDrill WDX Bodies - 2XD - METRIC										
Catalog Number	Stock	øD _c	L	l ₁	l ₂	øD ₁	øD _s	l _s	Insert	Fig.
WDX130D2S20	★	13.0	88	44	29					
WDX135D2S20	★	13.5	89	45	30					
WDX140D2S20	★	14.0	90	46	31	28.0	20	44	WDXT 042004	
WDX145D2S20	★	14.5	91	47	32					
WDX150D2S20	★	15.0	92	48	33					
WDX155D2S20	★	15.5	93	49	34					
WDX160D2S20	★	16.0	94	50	35	30.0	20	44	WDXT 052504	
WDX165D2S20	★	16.5	95	51	36					
WDX170D2S20	★	17.0	96	52	37					
WDX175D2S25	★	17.5	109	53	38	32.0	25	56		
WDX180D2S25	★	18.0	110	54	39					
WDX185D2S25	★	18.5	111	55	40					
WDX190D2S25	★	19.0	112	56	41					
WDX195D2S25	★	19.5	113	57	42					
WDX200D2S25	★	20.0	114	58	43					
WDX205D2S25	★	20.5	115	59	44	33.0	25	56	WDXT 063006	
WDX210D2S25	★	21.0	116	60	45					
WDX215D2S25	★	21.5	117	61	46					
WDX220D2S25	★	22.0	118	62	47					
WDX225D2S25	★	22.5	119	63	48					
WDX230D2S25	★	23.0	123	67	49					
WDX235D2S25	★	23.5	124	68	50	37.0	25	56		
WDX240D2S25	★	24.0	125	69	51					
WDX245D2S25	★	24.5	126	70	52					
WDX250D2S25	★	25.0	127	71	53					
WDX255D2S32	★	25.5	134	74	54					
WDX260D2S32	★	26.0	135	75	55				WDXT 073506	
WDX265D2S32	★	26.5	136	76	56					
WDX270D2S32	★	27.0	137	77	57	41.0	32	60		
WDX275D2S32	★	27.5	138	78	58					
WDX280D2S32	★	28.0	139	79	59					
WDX285D2S32	★	28.5	140	80	60					
WDX290D2S32	★	29.0	143	83	62	50.0	32	60		
WDX295D2S32	★	29.5	144	84	63					
WDX300D2S40	★	30.0	158	88	64					
WDX310D2S40	★	31.0	160	90	66				WDXT 094008	
WDX320D2S40	★	32.0	162	92	68	54.0	40	70		
WDX330D2S40	★	33.0	164	94	70					
WDX340D2S40	★	34.0	166	96	72					
WDX350D2S40	★	35.0	168	98	74					
WDX360D2S40	★	36.0	170	100	76					
WDX370D2S40	★	37.0	179	109	79					
WDX380D2S40	★	38.0	181	111	81					
WDX390D2S40	★	39.0	183	113	83					
WDX400D2S40	★	40.0	185	115	85	49.5	40	70	WDXT 125012	
WDX410D2S40	★	41.0	187	117	87					
WDX420D2S40	★	42.0	189	119	89					
WDX430D2S40	★	43.0	191	121	91					
WDX440D2S40	★	44.0	193	123	93					
WDX450D2S40	★	45.0	195	125	95					
WDX460D2S40	★	46.0	197	127	97					
WDX470D2S40	★	47.0	199	129	99	49.5				
WDX480D2S40	★	48.0	201	131	101					
WDX490D2S40	★	49.0	203	133	103					
WDX500D2S40	★	50.0	205	135	105					
WDX510D2S40	★	51.0	207	137	107	40	70		WDXT 156012	
WDX520D2S40	★	52.0	209	139	109	50.5				
WDX530D2S40	★	53.0	211	141	111	51.5				
WDX540D2S40	★	54.0	213	143	113	52.5				
WDX550D2S40	★	55.0	215	145	115	53.5				
WDX560D2S40	★	56.0	222	152	120	54.0				
WDX570D2S40	★	57.0	224	154	122	55.0				
WDX580D2S40	★	58.0	226	156	124	56.0				
WDX590D2S40	★	59.0	228	158	126	57.0				
WDX600D2S40	★	60.0	230	160	128	58.0				
WDX610D2S40	★	61.0	232	162	130	59.0				
WDX620D2S40	★	62.0	234	164	132	60.0	40	70	WDXT 186012	
WDX630D2S40	★	63.0	236	166	134	61.0				
WDX640D2S40	★	64.0	238	168	136	62.0				
WDX650D2S40	★	65.0	240	170	138	63.0				
WDX660D2S40	★	66.0	242	172	140	64.0				
WDX670D2S40	★	67.0	244	174	142	65.0				
WDX680D2S40	★	68.0	246	176	144	66.0				

★ = Worldwide Warehouse item

SumiDrill WDX Bodies - 3XD - METRIC										
Catalog Number	Stock	øD _c	L	l ₁	l ₂	øD ₁	øD _s	l _s	Insert	Fig.
WDX130D3S20	★	13.0	101.0	57.0	42.0					
WDX135D3S20	★	13.5	102.5	58.5	43.5					
WDX140D3S20	★	14.0	104.0	60.0	45.0	28.0	20	44	WDXT 042004	
WDX145D3S20	★	14.5	105.5	61.5	46.5					
WDX150D3S20	★	15.0	107.0	63.0	48.0					
WDX155D3S20	★	15.5	108.5	64.5	49.5					
WDX160D3S20	★	16.0	110.0	66.0	51.0	30.0	20	44	WDXT 052504	
WDX165D3S20	★	16.5	111.5	67.5	52.5					
WDX170D3S20	★	17.0	113.0	69.0	54.0					
WDX175D3S25	★	17.5	126.5	70.5	55.5	32.0	25	56		
WDX180D3S25	★	18.0	128.0	72.0	57.0					
WDX185D3S25	★	18.5	129.5	73.5	58.5					
WDX190D3S25	★	19.0	131.0	75.0	60.0					
WDX195D3S25	★	19.5	132.5	76.5	61.5					
WDX200D3S25	★	20.0	134.0	78.0	63.0					
WDX205D3S25	★	20.5	135.5	79.5	64.5	33.0	25	56	WDXT 063006	
WDX210D3S25	★	21.0	137.0	81.0	66.0					
WDX215D3S25	★	21.5	138.5	82.5	67.5					
WDX220D3S25	★	22.0	140.0	84.0	69.0					
WDX225D3S25	★	22.5	141.5	85.5	70.5					
WDX230D3S25	★	23.0	146.0	90.0	72.0					
WDX235D3S25	★	23.5	147.5	91.5	73.5	37.0	25	56		
WDX240D3S25	★	24.0	149.0	93.0	75.0					
WDX245D3S25	★	24.5	150.5	94.5	76.5					
WDX250D3S25	★	25.0	152.0	96.0	78.0					
WDX255D3S32	★	25.5	159.5	99.5	79.5				WDXT 073506	
WDX260D3S32	★	26.0	161.0	101.0	81.0					
WDX265D3S32	★	26.5	162.5	102.5	82.5					
WDX270D3S32	★	27.0	164.0	104.0	84.0	41.0	32	60		
WDX275D3S32	★	27.5	165.5	105.5	85.5					
WDX280D3S32	★	28.0	167.0	107.0	87.0					
WDX285D3S32	★	28.5	168.5	108.5	88.5					
WDX290D3S32	★	29.0	172.0	112.0	91.0	50.0	32	60		
WDX295D3S32	★	29.5	173.5	113.5	92.5					
WDX300D3S40	★	30.0	188.0	118.0	94.0					
WDX310D3S40	★	31.0	191.0	121.0	97.0				WDXT 094008	
WDX320D3S40	★	32.0	194.0	124.0	100.0	54.0	40	70		
WDX330D3S40	★	33.0	197.0	127.0	103.0					
WDX340D3S40	★	34.0	200.0	130.0	106.0					
WDX350D3S40	★	35.0	203.0	133.0	109.0					
WDX360D3S40	★	36.0	206.0	136.0	112.0					
WDX370D3S40	★	37.0	216.0	146.0	116.0					
WDX380D3S40	★	38.0	219.0	149.0	119.0					
WDX390D3S40	★	39.0	222.0	152.0	122.0					
WDX400D3S40	★	40.0	225.0	155.0	125.0	49.5	40	70	WDXT 125012	
WDX410D3S40	★	41.0	228.0	158.0	128.0					
WDX420D3S40	★	42.0	231.0	161.0	131.0					
WDX430D3S40	★	43.0	234.0	164.0	134.0					
WDX440D3S40	★	44.0	237.0	167.0	137.0					
WDX450D3S40	★	45.0	240.0	170.0	140.0					
WDX460D3S40	★	46.0	243.0	173.0	143.0					
WDX470D3S40	★	47.0	246.0	176.0	146.0	49.5				
WDX480D3S40	★	48.0	249.0	179.0	149.0					
WDX490D3S40	★	49.0	252.0	182.0	152.0					
WDX500D3S40	★	50.0	255.0	185.0	155.0					
WDX510D3S40	★	51.0	258.0	188.0	158.0	40	70		WDXT 156012	
WDX520D3S40	★	52.0	261.0	191.0	161.0	50.5				
WDX530D3S40	★	53.0	264.0	194.0	164.0	51.5				
WDX540D3S40	★	54.0	267.0	197.0	167.0	52.5				
WDX550D3S40	★	55.0	270.0	200.0	170.0	53.5				
WDX560D3S40	★	56.0	278.0	208.0	176.0	54.0				
WDX570D3S40	★	57.0	281.0	211.0	179.0	55.0				
WDX580D3S40	★	58.0	284.0	214.0	182.0	56.0				
WDX590D3S40	★	59.0	287.0	217.0	185.0	57.0				
WDX600D3S40	★	60.0	290.0	220.0	188.0	58.0				
WDX610D3S40	★	61.0	293.0	223.0	191.0					

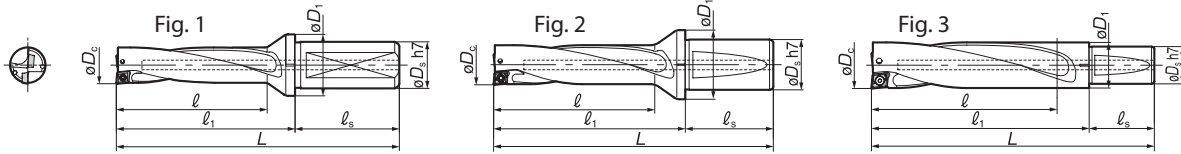

SumiDrill WDX Bodies - 4XD - METRIC										
Catalog Number	Stock	øD _c	L	ℓ ₁	ℓ	øD ₁	øD ₂	ℓ ₂	Insert	Fig.
WDX130D4S20	★	13.0	114	70	55					
WDX135D4S20	★	13.5	116	72	57					
WDX140D4S20	★	14.0	118	74	59	28.0	20	44	WDXT 042004	
WDX145D4S20	★	14.5	120	76	61					
WDX150D4S20	★	15.0	122	78	63					
WDX155D4S20	★	15.5	124	80	65					
WDX160D4S20	★	16.0	126	82	67	30.0	20	44	WDXT 052504	
WDX165D4S20	★	16.5	128	84	69					
WDX170D4S20	★	17.0	130	86	71					
WDX175D4S25	★	17.5	144	88	73	32.0	25	56		
WDX180D4S25	★	18.0	146	90	75					
WDX185D4S25	★	18.5	148	92	77					
WDX190D4S25	★	19.0	150	94	79					1
WDX195D4S25	★	19.5	152	96	81					
WDX200D4S25	★	20.0	154	98	83					
WDX205D4S25	★	20.5	156	100	85	33.0	25	56	WDXT 063006	
WDX210D4S25	★	21.0	158	102	87					
WDX215D4S25	★	21.5	160	104	89					
WDX220D4S25	★	22.0	162	106	91					
WDX225D4S25	★	22.5	164	108	93					
WDX230D4S25	★	23.0	169	113	95					
WDX235D4S25	★	23.5	171	115	97					
WDX240D4S25	★	24.0	173	117	99	37.0	25	56		
WDX245D4S25	★	24.5	175	119	101					
WDX250D4S25	★	25.0	177	121	103					
WDX255D4S32	★	25.5	185	125	105				WDXT 073506	
WDX260D4S32	★	26.0	187	127	107					
WDX265D4S32	★	26.5	189	129	109					
WDX270D4S32	★	27.0	191	131	111	41.0	32	60		
WDX275D4S32	★	27.5	193	133	113					
WDX280D4S32	★	28.0	195	135	115					
WDX285D4S32	★	28.5	197	137	117					
WDX290D4S32	★	29.0	201	141	120					
WDX295D4S32	★	29.5	203	143	122	50.0	32	60		
WDX300D4S40	★	30.0	218	148	124					
WDX310D4S40	★	31.0	222	152	128					
WDX320D4S40	★	32.0	226	156	132				WDXT 094008	
WDX330D4S40	★	33.0	230	160	136	54.0	40	70		
WDX340D4S40	★	34.0	234	164	140					
WDX350D4S40	★	35.0	238	168	144					
WDX360D4S40	★	36.0	242	172	148					
WDX370D4S40	★	37.0	253	183	153					
WDX380D4S40	★	38.0	257	187	157					
WDX390D4S40	★	39.0	261	191	161					
WDX400D4S40	★	40.0	265	195	165					
WDX410D4S40	★	41.0	269	199	169	49.5	40	70	WDXT 125012	
WDX420D4S40	★	42.0	273	203	173					
WDX430D4S40	★	43.0	277	207	177					
WDX440D4S40	★	44.0	281	211	181					
WDX450D4S40	★	45.0	285	215	185					
WDX460D4S40	★	46.0	289	219	189					
WDX470D4S40	★	47.0	293	223	193					
WDX480D4S40	★	48.0	297	227	197	49.5				
WDX490D4S40	★	49.0	301	231	201					
WDX500D4S40	★	50.0	305	235	205					
WDX510D4S40	★	51.0	309	239	209		40	70	WDXT 156012	
WDX520D4S40	★	52.0	313	243	213	50.5				
WDX530D4S40	★	53.0	317	247	217	51.5				
WDX540D4S40	★	54.0	321	251	221	52.5				
WDX550D4S40	★	55.0	325	255	225	53.5				
WDX560D4S40	★	56.0	334	264	232	54.0				
WDX570D4S40	★	57.0	338	268	236	55.0				
WDX580D4S40	★	58.0	342	272	240	56.0				
WDX590D4S40	★	59.0	346	276	244	57.0				
WDX600D4S40	★	60.0	350	280	248	58.0	40	70	WDXT 186012	
WDX610D4S40	★	61.0	354	284	252	59.0				
WDX620D4S40	★	62.0	358	288	256	60.0				
WDX630D4S40	★	63.0	362	292	260	61.0				

★ = Worldwide Warehouse item

SumiDrill WDX Bodies - 5XD - METRIC											
Catalog Number	Stock	øD _c	L	ℓ ₁	ℓ	øD ₁	øD ₂	ℓ ₂	Insert	Fig.	Coolant Sleeve**
WDX 130D5S20	★	13.0	127.0	83.0	68.0						
WDX 135D5S20	★	13.5	129.5	85.5	70.5						
WDX 140D5S20	★	14.0	132.0	88.0	73.0	28.0	20.0	44.0	WDXT 042004		SLV20M
WDX 145D5S20	★	14.5	134.5	90.5	75.5						
WDX 150D5S20	★	15.0	137.0	93.0	78.0						
WDX 155D5S20	★	15.5	139.5	95.5	80.5						
WDX 160D5S20	★	16.0	142.0	98.0	83.0	30.0	20.0	44.0	WDXT 052504		
WDX 165D5S20	★	16.5	144.5	100.5	85.5						
WDX 170D5S20	★	17.0	147.0	103.0	88.0						
WDX 175D5S25	★	17.5	161.5	105.5	90.5						
WDX 180D5S25	★	18.0	164.0	108.0	93.0	32.0	25.0	56.0			
WDX 185D5S25	★	18.5	166.5	110.5	95.5						
WDX 190D5S25	★	19.0	169.0	113.0	98.0					1	
WDX 195D5S25	★	19.5	171.5	115.5	100.5						
WDX 200D5S25	★	20.0	174.0	118.0	103.0						
WDX 205D5S25	★	20.5	176.5	120.5	105.5	33.0	25.0	56.0	WDXT 063006		SLV25M
WDX 210D5S25	★	21.0	179.0	123.0	108.0						
WDX 215D5S25	★	21.5	181.5	125.5	110.5						
WDX 220D5S25	★	22.0	184.0	128.0	113.0						
WDX 225D5S25	★	22.5	186.5	130.5	115.5						
WDX 230D5S25	★	23.0	192.0	136.0	118.0						
WDX 235D5S25	★	23.5	194.5	138.5	120.5						
WDX 240D5S25	★	24.0	197.0	141.0	123.0	37.0	25.0	56.0	WDXT 073506		
WDX 245D5S25	★	24.5	199.5	143.5	125.5						
WDX 250D5S25	★	25.0	202.0	146.0	128.0						
WDX 260D5S32	★	26.0	213.0	153.0	133.0						
WDX 270D5S32	★	27.0	218.0	158.0	138.0	41.0		60.0			
WDX 280D5S32	★	28.0	223.0	163.0	143.0						
WDX 290D5S32	★	29.0	230.0	170.0	149.0	50.0	32.0				SLV32M
WDX 300D5S32	★	30.0	238.0	178.0	154.0						
WDX 310D5S32	★	31.0	243.0	183.0	159.0						
WDX 320D5S32	★	32.0	248.0	188.0	164.0						
WDX 300D5S40	★	30.0	248.0	178.0	154.0						
WDX 310D5S40	★	31.0	253.0	183.0	159.0	54.0			WDXT 094008		
WDX 320D5S40	★	32.0	258.0	188.0	164.0						
WDX 330D5S40	★	33.0	263.0	193.0	169.0		40.0	70.0			SLV40M
WDX 340D5S40	★	34.0	268.0	198.0	174.0						
WDX 350D5S40	★	35.0	273.0	203.0	179.0						
WDX 360D5S40	★	36.0	278.0	208.0	184.0						

★ = Worldwide Warehouse item

*NOTE: Coolant adapter sleeves for lathes are available upon request.

** : Coolant adapter sleeves sold separately

*** 5XD WDX Drills have 2 coolant holes in the back of the drill and no single threaded port see next page (pg. 509) for Coolant Adapter Info



SumiDrill WDX Inserts

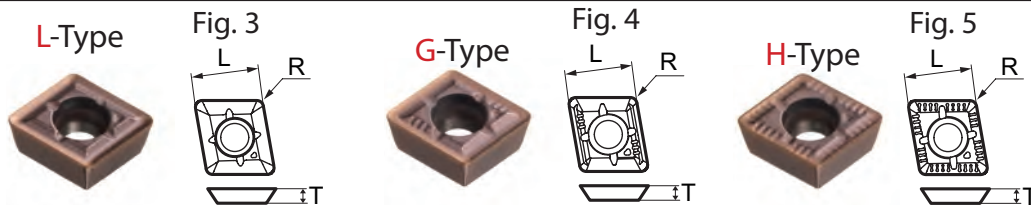

Catalog Number	NEW GRADE Stock				Fig.	L	T	R	WDX Body
	ACP100	ACP300	ACK300	DL1500					
WDX042004-L	●	●	●		3				
WDX042004-G	●	●	●	●	4	0.1654	0.0788	0.0157	WDX0562D□ ~ WDX0594D□
WDX042004-H	●	●	●		5				
WDX052504-L	●	●	●		3				
WDX052504-G	●	●	●	●	4	0.1969	0.0984	0.0157	WDX0625D□ ~ WDX0687D□
WDX052504-H	●	●	●		5				
WDX063006-L	●	●	●		3				
WDX063006-G	●	●	●	●	4	0.2362	0.1181	0.0236	WDX0750D□ ~ WDX0875D□
WDX063006-H	●	●	●		5				
WDX073506-L	●	●	●		3				
WDX073506-G	●	●	●	●	4	0.2953	0.1378	0.0236	WDX0937D□ ~ WDX1125D□
WDX073506-H	●	●	●		5				
WDX094008-L	●	●	●		3				
WDX094008-G	●	●	●	●	4	0.3780	0.1575	0.0315	WDX1187D□ ~ WDX1437D□
WDX094008-H	●	●	●		5				
WDX125012-L	●	●	●		3				
WDX125012-G	●	●	●	●	4	0.4882	0.1969	0.0472	WDX1500D□ ~ WDX1750D□
WDX125012-H	●	●	●		5				
WDX156012-L	●	●	●		3				
WDX156012-G	●	●	●	●	4	0.5984	0.2362	0.0472	WDX1813D□ ~ WDX2125D□
WDX156012-H	●	●	●		5				
WDX186012-L	●	●	●		3				
WDX186012-G	●	●	●	●	4	0.7087	0.2362	0.0472	WDX2250D□ ~ WDX2625D□
WDX186012-H	●	●	●		5				

Coolant Adapter Sleeves

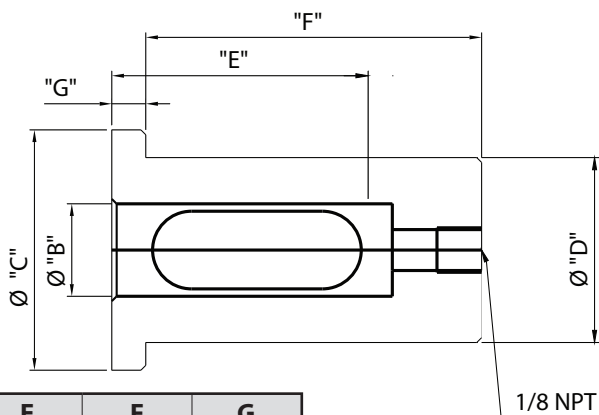

Product Code	B	C	D	E	F	G
SLV075	.750	1.949	1.500	2.000	3.000	0.280
SLV1000	1.000	1.949	1.500	2.500	3.000	0.280
SLV1250	1.250	1.949	1.500	2.500	3.000	0.280
SLV1250L	1.250	1.949	1.500	3.000	3.000	0.780
SLV1500	1.500	2.500	2.000	3.000	3.000	0.780
SLV20M	20 mm	1.949	1.500	2.000	3.000	0.280
SLV25M	25 mm	1.949	1.500	2.500	3.000	0.280
SLV32M	32 mm	1.949	1.500	2.500	3.000	0.280
SLV40M	40 mm	2.500	2.000	3.000	3.000	0.780



WDX	Work Material	Hardness HB	Chip Breaker	Insert Grade	Cutting Speed SFM	Feed Rate - IPR (Inches per revolution)			
						ø0.562 - ø1.00	ø1.062 - ø1.50	ø1.56 - ø2.125	ø2.25 - ø2.625
2D	P Low Carbon Steel	<190	G	ACP300	450 - 780	.002 - .006	.003 - .008	.005 - .010	.006 - .012
			L	ACP300	450 - 750	.002 - .004	.002 - .005	.003 - .006	N/A
		190 ~ 250	G	ACP300	400 - 700	.003 - .009	.004 - .010	.005 - .010	.006 - .012
			L	ACP300	400 - 700	.002 - .004	.002 - .005	.003 - .006	N/A
		250 ~ 300	G	ACP300	350 - 550	.003 - .007	.003 - .008	.004 - .009	.004 - .010
			L	ACP300	350 - 525	.002 - .004	.002 - .004	.003 - .005	N/A
	Medium Carbon Steel	180 ~ 275	G	ACP300	350 - 700	.002 - .007	.003 - .008	.005 - .010	.006 - .010
			L	ACP300	350 - 650	.002 - .004	.002 - .005	.003 - .006	N/A
		275 ~ 350	G	ACP300	300 - 500	.002 - .006	.003 - .007	.004 - .008	.006 - .009
			L	ACP300	300 - 500	.002 - .003	.002 - .004	.003 - .005	N/A
	Alloy Steel	200 ~ 350	G	ACP300	350 - 650	.003 - .006	.003 - .008	.006 - .010	.006 - .012
			L	ACP300	300 - 450	.002 - .004	.003 - .005	.003 - .006	N/A
	M 300 Austenitic Stainless Steel	160	G	ACP300	400 - 650	.003 - .007	.003 - .008	.005 - .010	.006 - .012
		280	G	ACP300	325 - 500	.002 - .006	.003 - .006	.004 - .008	.006 - .010
	400 Martensitic Stainless Steel	160	G	ACP300	400 - 650	.003 - .007	.003 - .008	.004 - .010	.006 - .012
		240	G	ACP300	325 - 600	.002 - .006	.003 - .006	.004 - .008	.006 - .010
	K Cast Iron		H	ACK300	400 - 650	.004 - .008	.004 - .012	.006 - .014	.006 - .017
			H	ACK300	300 - 500	.004 - .008	.004 - .012	.006 - .014	.006 - .017
S Exotic Alloys	200 ~ 375	G	ACP300	80 - 250	.002 - .005	.003 - .007	.003 - .008	.003 - .010	
N Aluminum alloy		G	DL1500	650 - 1200	.003 - .006	.003 - .007	.004 - .008	.005 - .010	
	Copper Alloy		G	DL1500	600 - 900	.003 - .006	.003 - .007	.004 - .008	.005 - .010

WDX	Work Material	Hardness HB	Chip Breaker	Insert Grade	Cutting Speed SFM	Feed Rate - IPR (Inches per revolution)			
						ø0.562 - ø1.00	ø1.062 - ø1.50	ø1.56 - ø2.125	ø2.25 - ø2.625
3D	P Low Carbon Steel	<190	G	ACP300	450 - 780	.002 - .006	.003 - .008	.005 - .010	.006 - .012
			L	ACP300	450 - 750	.002 - .004	.002 - .005	.003 - .006	N/A
		190 ~ 250	G	ACP300	400 - 700	.003 - .009	.004 - .010	.005 - .010	.006 - .012
			L	ACP300	400 - 700	.002 - .004	.002 - .005	.003 - .006	N/A
		250 ~ 350	G	ACP300	350 - 550	.003 - .007	.003 - .008	.004 - .009	.004 - .010
			L	ACP300	350 - 525	.002 - .004	.002 - .004	.003 - .005	N/A
	Medium Carbon Steel	180 ~ 275	G	ACP300	350 - 700	.002 - .007	.003 - .008	.005 - .010	.006 - .010
			L	ACP300	350 - 650	.002 - .004	.002 - .005	.003 - .006	N/A
		275 ~ 350	G	ACP300	300 - 500	.002 - .006	.003 - .007	.004 - .008	.006 - .009
			L	ACP300	300 - 500	.002 - .003	.002 - .004	.003 - .005	N/A
	Alloy Steel	200 ~ 350	G	ACP300	350 - 650	.003 - .006	.003 - .008	.006 - .010	.006 - .012
			L	ACP300	300 - 450	.002 - .004	.003 - .005	.003 - .006	N/A
	M 300 Austenitic Stainless Steel	160	G	ACP300	400 - 650	.003 - .007	.003 - .008	.005 - .010	.006 - .012
		280	G	ACP300	325 - 500	.002 - .006	.003 - .006	.004 - .008	.006 - .010
	400 Martensitic Stainless Steel	160	G		400 - 650	.003 - .007	.003 - .008	.004 - .010	.006 - .012
		240	G	ACP300	325 - 600	.002 - .006	.003 - .006	.004 - .008	.006 - .010
	K Cast Iron		H	ACK300	400 - 650	.004 - .008	.004 - .012	.006 - .014	.006 - .017
			H	ACK300	300 - 500	.004 - .008	.004 - .012	.006 - .014	.006 - .017
S Exotic Alloys	200 ~ 375	G	ACP300	80 - 250	.002 - .005	.003 - .007	.003 - .008	.003 - .010	
N Aluminum alloy		G	DL1500	650 - 1200	.003 - .006	.003 - .007	.004 - .008	.005 - .010	
	Copper Alloy		G	DL1500	600 - 900	.003 - .006	.003 - .007	.004 - .008	.005 - .010



WDX	Work Material	Hardness HB	Chip Breaker	Insert Grade	Cutting Speed SFM	Feed Rate - IPR (Inches per revolution)			
						ø0.562 - ø1.00	ø1.062 - ø1.50	ø1.56 - ø2.125	ø2.25 - ø2.625
4D	P Low Carbon Steel	<190	G	ACP300	450 - 780	.002 - .004	.003 - .006	.004 - .007	.004 - .008
			L	ACP300	450 - 750	.002 - .004	.002 - .004	.003 - .005	N/A
		190 ~ 250	G	ACP300	400 - 700	.003 - .006	.003 - .007	.005 - .008	.004 - .009
			L	ACP300	400 - 700	.002 - .004	.002 - .005	.003 - .006	N/A
		250 ~ 350	G	ACP300	350 - 550	.003 - .006	.003 - .007	.003 - .007	.004 - .008
			L	ACP300	350 - 525	.002 - .004	.002 - .004	.003 - .005	N/A
	Medium Carbon Steel	180 ~ 275	G	ACP300	350 - 700	.003 - .006	.003 - .008	.004 - .008	.006 - .010
			L	ACP300	350 - 650	.002 - .004	.002 - .005	.003 - .005	N/A
		275 ~ 350	G	ACP300	300 - 500	.003 - .005	.003 - .007	.004 - .008	.005 - .009
			L	ACP300	300 - 500	.002 - .003	.002 - .004	.003 - .005	N/A
	Alloy Steel	200 ~ 350	G	ACP300	350 - 650	.003 - .006	.003 - .008	.004 - .008	.006 - .010
			L	ACP300	300 - 450	.002 - .004	.003 - .005	.003 - .006	N/A
	M 300 Austenitic Stainless Steel	160	G	ACP300	400 - 650	.003 - .006	.003 - .007	.005 - .008	.005 - .009
		280	G	ACP300	325 - 500	.002 - .005	.003 - .005	.004 - .006	.004 - .008
	400 Martensitic Stainless Steel	160	G	ACP300	400 - 650	.003 - .006	.003 - .007	.004 - .008	.006 - .010
		240	G	ACP300	325 - 600	.002 - .005	.003 - .005	.004 - .006	.005 - .008
K Cast Iron		H	ACK300	400 - 650	.004 - .008	.004 - .012	.006 - .012	.006 - .014	
		H	ACK300	300 - 500	.004 - .008	.004 - .012	.006 - .012	.006 - .014	
S Exotic Alloys	200 ~ 375	G	ACP300	80 - 250	.002 - .004	.002 - .005	.003 - .006	.004 - .007	
N Aluminum alloy		G	DL1500	650 - 1200	.003 - .006	.003 - .007	.004 - .008	.005 - .010	
		G	DL1500	600 - 900	.003 - .006	.003 - .007	.004 - .008	.005 - .010	

Indexable Drills

WDX	Work Material	Hardness HB	Chip Breaker	Insert Grade	Cutting Speed SFM	Feed Rate - IPR (Inches per revolution)			
						ø0.562 - ø1.00	ø1.062 - ø1.50	ø1.56 - ø2.125	ø2.25 - ø2.625
5D	P Low Carbon Steel	<190	G	ACP300	450 - 780	.002 - .004	.003 - .006	.004 - .007	
			L	ACP300	450 - 750	.002 - .004	.002 - .005	.002 - .005	
		190 ~ 250	G	ACP300	400 - 700	.003 - .006	.003 - .007	.005 - .008	
			L	ACP300	400 - 700	.002 - .004	.002 - .005	.002 - .005	
		250 ~ 350	G	ACP300	350 - 550	.003 - .006	.003 - .007	.003 - .007	
			L	ACP300	350 - 525	.002 - .004	.002 - .004	.002 - .005	
	Medium Carbon Steel	180 ~ 275	G	ACP300	350 - 700	.003 - .006	.003 - .008	.004 - .008	
			L	ACP300	350 - 650	.002 - .004	.002 - .005	.002 - .005	
		275 ~ 350	G	ACP300	300 - 500	.003 - .005	.003 - .007	.004 - .008	
			L	ACP300	300 - 500	.002 - .003	.002 - .004	.002 - .005	
	Alloy Steel	200 ~ 350	G	ACP300	350 - 650	.003 - .006	.003 - .008	.004 - .008	
			L	ACP300	300 - 450	.002 - .004	.003 - .005	.003 - .006	
	M 300 Austenitic Stainless Steel	160	G	ACP300	400 - 650	.002 - .004	.003 - .006	.003 - .007	
		280	G	ACP300	325 - 500	.001 - .003	.003 - .005	.003 - .006	
	400 Martensitic Stainless Steel	160	G	ACP300	400 - 650	.002 - .004	.003 - .006	.003 - .007	
		240	G	ACP300	325 - 600	.001 - .003	.003 - .005	.003 - .006	
K Cast Iron		H	ACK300	400 - 650	.004 - .008	.004 - .010	.005 - .011		
		H	ACK300	300 - 500	.004 - .008	.004 - .010	.005 - .011		
S Exotic Alloys	200 ~ 375	G	ACP300	80 - 250	.002 - .004	.003 - .006	.003 - .007		
N Aluminum alloy		G	DL1500	650 - 1200	.003 - .006	.003 - .007	.004 - .008		
		G	DL1500	600 - 900	.003 - .006	.003 - .007	.004 - .008		



2XD, 3XD, 4XD & 5XD-METRIC PDL / PCT Type

SEC Plunge Drill and Mill



Features & Benefits

- The tool cuts in the Z axis direction where tool rigidity is highest, allowing high efficiency roughing for aeronautic components and in applications with long tool overhang must be used to machine deep holes and pockets.
- The flat cutting edge design produces near-flat bottom profiles to reduce depth of cut variation during finishing.
- All sizes come with an air hole for supplying coolant internally to improve chip evacuation.
- The tools use SumiDrill WDX type inserts for handling a wide range of work materials, from steel to non-ferrous metals and exotic alloys.

Characteristics

- The PDL type has a central insert making it possible to make radial cuts beyond the tool's radius, pitch feed cutting, and drilling. (Pocket milling, etc.)

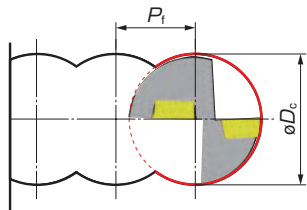
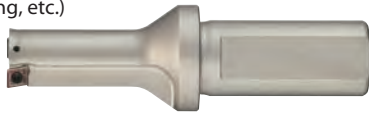

Keep the value of Pf for PDL type tools to less than 70% of the tool diameter (øDc).

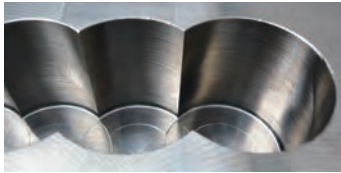

- Although the PCT type has limited radial cutting ability, the tool has many effective teeth enabling it to perform high feed cutting. (Medium finishing of corners, hole expansion, deep grooving, etc.)

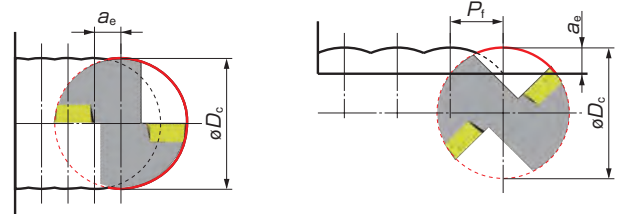

Keep the value of Pf for PCT type tools to less than 50% of the tool diameter (øDc). For a_e , refer to the dimension under "a_e max" in the stock/dimensions tables titled "Holders Max. Depth: 3D/5D".

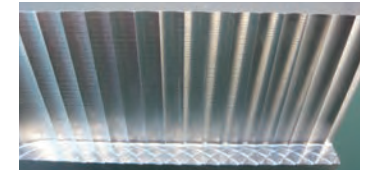

Application Examples

Pocketing **PDL** Work Material: Ti Alloy

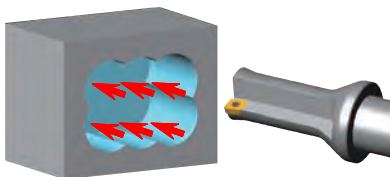

Tool: PDL400D2540 (ø40)
Insert: WDXT125012-G
Grade: ACK300
Cutting Speed: $v_c=130$ sfm
Feed Rate: $f=0.003$ ipr
Depth of Cut: $a_e(\rho)=1$ in.

Corner Finishing **PCT** Work Piece: Ti Alloy

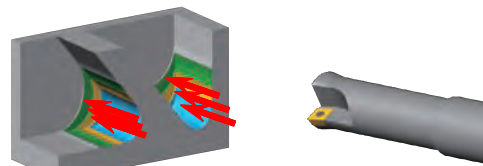

Tool: PCT320D3532 (ø32)
PCT250D3525 (ø25)
PCT200D3520 (ø20)
Grade: ACK300
Insert: WDXT094008-G
WDXT073506-G
WDXT063006-G
Cutting Speed: $v_c=165$ sfm
Feed Rate: $f_z=0.0031$ ipt
Depth of Cut: $a_e=0.13$ to 0.26 in.

Grooving **PCT** Work Piece: Ti Alloy

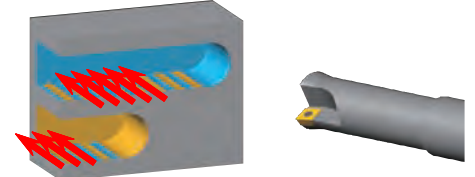

Tool: PCT320D5532 (ø32)
Insert: WDXT094008-G
Grade: ACK300
Cutting Speed: $v_c=130$ sfm
Feed Rate: $f_z=0.0027$ ipt
Depth of Cut: $a_e(\rho)=0.20$ in.

Drilling **PDL** Work Material: SUS316

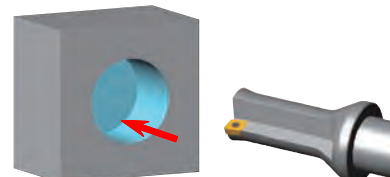

Tool: PDL200D3525 (ø20)
Insert: WDXT063006-G
Grade: ACP300
Cutting Speed: $v_c=600$ sfm
Feed Rate: $f=0.004$ ipr
Depth of Cut: $a_e=0.80$ in.

Aeronautic Components **PCT** Work Piece: SUS304

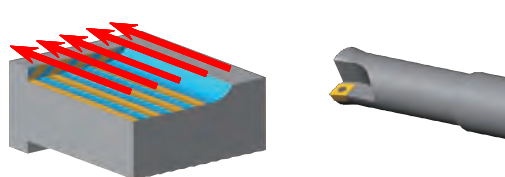

Tool: PCT320D3532 (ø32)
Insert: WDXT094008-G
Grade: ACP300
Cutting Speed: $v_c=600$ sfm
Feed Rate: $f_z=0.006$ ipt
Depth of Cut: $a_e=0.28$ in.
 $\rho=0.2$ in.

Machine Components **PCT** Work Piece: SCM435

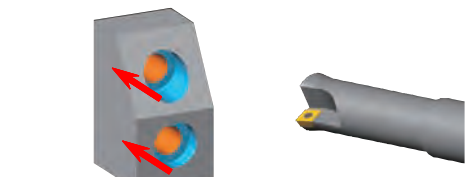

Tool: PCT200D5520 (ø20)
Insert: WDXT063006-G
Grade: ACK300
Cutting Speed: $v_c=500$ sfm
Feed Rate: $f_z=0.006$ ipt
Depth of Cut: $a_e=0.14$ in.



Carbon Steel Up to 0.28% C	Alloy Steel From 0.29% C	Tempered Steel	Hardened Steel Up to 45HRC	Stainless Steel From 46HRC	Ti-Alloy	Heat-resistant steels	Cast Iron	Ductile Cast Iron	Aluminum Alloy	Copper Alloy	Composite CFRP
○	○	○	○	○	○	○	○	○	○	○	○

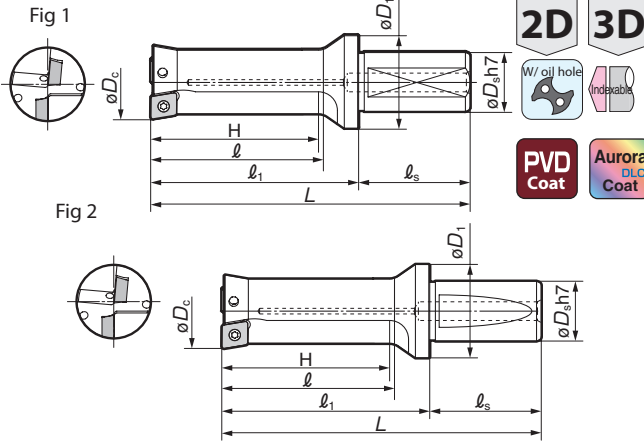

Carbon Steel Up to 0.28% C	Alloy Steel From 0.29% C	Tempered Steel	Hardened Steel Up to 45HRC	Stainless Steel From 46HRC	Ti-Alloy	Heat-resistant steels	Cast Iron	Ductile Cast Iron	Aluminum Alloy	Copper Alloy	Composite CFRP
○	○	○	○	○	○	○	○	○	○	○	○

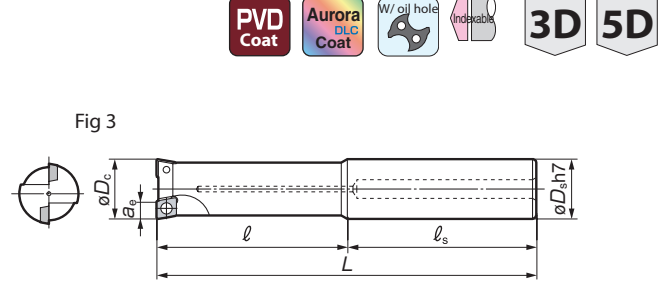

PDL Metric 2XD											
Cat. No.	Stock	Dimensions (mm)							Applicable Insert	Fig.	
		ϕD_c	L	ℓ_1	ℓ	ϕD_1	ϕD_s	ℓ_s			H
PDL 160D2S20	★	16.0	94	50	35	28	20	44	32	WDXT052504	1
200D2S25	★	20.0	114	58	43	33	25	56	40	WDXT063006	
250D2S25	★	25.0	127	71	53	37	25	56	50	WDXT073506	
PDL 320D2S40	★	32.0	162	92	68	54	40	70	64	WDXT094008	2
400D2S40	★	40.0	185	115	85	54	40	70	80	WDXT125012	

PDL Metric 3XD											
Cat. No.	Stock	Dimensions (mm)							Applicable Insert	Fig.	
		ϕD_c	L	ℓ_1	ℓ	ϕD_1	ϕD_s	ℓ_s			H
PDL 160D3S20	★	16.0	110	66	51	28	20	44	48	WDXT052504	1
200D3S25	★	20.0	134	78	63	33	25	56	60	WDXT063006	
250D3S25	★	25.0	152	96	78	37	25	56	75	WDXT073506	
PDL 320D3S40	★	32.0	194	124	100	54	40	70	96	WDXT094008	2
400D3S40	★	40.0	225	155	125	54	40	70	120	WDXT125012	

PCT Metric 3XD										
Cat. No.	Stock	Dimensions (mm)							Applicable Insert	Fig.
		ϕD_c	a_e max	L	ℓ	ℓ_s	ϕD_s	No. of flutes		
PCT 160D3S16	★	16.0	4.0	123	53	70	16	2	WDXT052504	3
200D3S20	★	20.0	5.0	145	65	80	20	2	WDXT063006	
250D3S25	★	25.0	6.5	160	80	80	25	2	WDXT073506	
320D3S32	★	32.0	8.5	191	101	90	32	2	WDXT094008	3
400D3S42	★	40.0	11.0	225	125	100	42	3	WDXT125012	

PCT Metric 5XD										
Cat. No.	Stock	Dimensions (mm)							Applicable Insert	Fig.
		ϕD_c	a_e max	L	ℓ	ℓ_s	ϕD_s	No. of flutes		
PCT 160D5S16	★	16.0	4.0	155	85	70	16	2	WDXT052504	3
200D5S20	★	20.0	5.0	185	105	80	20	2	WDXT063006	
250D5S25	★	25.0	6.5	210	130	80	25	2	WDXT073506	
320D5S32	★	32.0	8.5	255	165	90	32	2	WDXT094008	3
400D5S42	★	40.0	11.0	305	205	100	42	3	WDXT125012	

Parts				
Screw	Spanner	Spanner	Recommended Tightening Torque (N·m)	Applicable Holders
BFTX0204N	TRX06	-	0.5	PDL160D2S20 PDL160D3S20 PCT160D3S16 PCT160D5S16
BFTY02206	-	TRD07	1.0	PDL200D2S25 PDL200D3S25 PCT200D3S20 PCT200D5S20
BFTX02506N	-	TRD08	1.5	PDL250D2S25 PDL250D3S25 PCT250D3S25 PCT250D5S25
BFTX03584	-	TRD15	3.5	PDL320D2S40 PDL320D3S40 PCT320D3S32 PCT320D5S32
BFTX0511N	-	TRD20	5.0	PDL400D2S40 PDL400D3S40 PCT400D3S42 PCT400D5S42

Fig 4

L Type Chipbreaker
(Low feed, chip management type)

Fig 5

G Type Chipbreaker
(General purpose type)

Fig 6

H Type Chipbreaker
(Strong edge type)

Application	Grade	Cutting Conditions				Fig.	Dimensions (mm)			Applicable Holders
		High Speed/Light	General Purpose	Roughing	ℓ		Thickness	r_e		
			M	P	K					
	ACP100					4	5.0	2.5	0.4	PDL160D2S20
	ACP300				5	PDL160D3S20				
	ACK300				6	PCT160D3S16				
	DL1500				6	PCT160D5S16				
					4	6.0	3.0	0.6	PDL200D2S25	
					5	7.5	3.5	0.6	PDL200D3S25	
					6				PCT200D3S20	
					6				PCT200D5S20	
					4	9.6	4.0	0.8	PDL250D2S25	
					5				PDL250D3S25	
					6				PCT250D3S25	
					6	PCT250D5S25				
					4	12.4	5.0	1.2	PDL320D2S40	
					5				PDL320D3S40	
					6				PCT320D3S32	
					6	PCT320D5S32				
					4	5.0	5.0	1.2	PDL400D2S40	
					5				PDL400D3S40	
					6				PCT400D3S42	
					6	PCT400D5S42				



Cutting Conditions PDL / PCT Type

SEC Plunge Drill & Mill

Indexable
Drills

Recommended Cutting Conditions PDL 2XD									
	Work Piece	Hardness HB	Recommended Breaker	Recommended Insert Grade	v _c Cutting Speed (sfm)	f Feed Rate (ipt) <Min.-Max.>			
						ø0.625"	ø0.75",ø1.000"	ø1.250"	ø1.500"
P	Steel, Carbon Steel A283 and similar Structural Steels	125	G	ACP300	390-790	0.002-0.004	0.002-0.004	0.002-0.004	0.002-0.005
	1015 Steel	125	L	ACP300	430-720	0.002-0.005	0.002-0.005	0.002-0.005	0.002-0.006
	1045 Steel	190	G	ACP300	330-660	0.003-0.009	0.003-0.009	0.003-0.010	0.004-0.011
	1045 Steel (Hardened)	250	G	ACP300	260-520	0.002-0.007	0.002-0.007	0.002-0.007	0.003-0.009
	1075 Steel	270	G	ACP300	330-520	0.003-0.008	0.003-0.008	0.003-0.009	0.004-0.010
	1075C Steel (Hardened)	300	G	ACP300	230-460	0.002-0.006	0.002-0.004	0.002-0.007	0.003-0.008
	Low Alloy Steel 4100, 4300 and 8600 Steels	180	L	ACP300	330-590	0.002-0.005	0.002-0.006	0.002-0.006	0.002-0.007
	4100, 4300 and 8600 Steels (Hardened)	275	G	ACP300	260-520	0.002-0.006	0.002-0.004	0.002-0.007	0.003-0.008
	4100, 4300 and 8600 Steels (Hardened)	300	G	ACP300	250-460	0.002-0.006	0.002-0.004	0.002-0.007	0.003-0.008
	4100, 4300 and 8600 Steels (Hardened)	350	G	ACP300	200-360	0.002-0.006	0.002-0.004	0.002-0.007	0.003-0.008
High Alloy Steel A2, D2 and other Tool and Die Steels	200	G	ACP300	330-520	0.003-0.009	0.003-0.009	0.003-0.010	0.004-0.011	
A2, D2 and other Tool and Die Steels (Hardened)	325	G	ACP300	260-390	0.002-0.007	0.002-0.007	0.002-0.007	0.003-0.009	
M	Stainless Steel 403 and other Martensitic and Ferritic Stainlesses	200	G	ACP300	330-590	0.002-0.007	0.002-0.007	0.002-0.007	0.003-0.009
	403 and other Martensitic Stainlesses (Hardened)	240	G	ACP300	300-490	0.002-0.007	0.002-0.007	0.002-0.007	0.003-0.009
	304, 316 and other Austenitic Stainlesses	180	G	ACP300	330-590	0.002-0.007	0.002-0.007	0.002-0.007	0.003-0.009
K	Cast Iron		H	ACK300	390-660	0.004-0.013	0.004-0.014	0.004-0.016	0.005-0.017
	Ductile Cast Iron		H	ACK300	300-490	0.004-0.013	0.004-0.014	0.004-0.016	0.005-0.017
S	Exotic Alloys (Heat Resistant Alloy, Super Alloy, Ti Alloy, etc.)	200	G	ACP300	80-230	0.002-0.007	0.002-0.007	0.002-0.019	0.003-0.009
N	Aluminium Alloy		G	DL1500	660-1050	0.002-0.006	0.002-0.004	0.002-0.007	0.003-0.008
	Copper Alloy		G	DL1500	590-920	0.002-0.006	0.002-0.004	0.002-0.007	0.003-0.008

Recommended Cutting Conditions PDL 3XD									
	Work Piece	Hardness HB	Recommended Breaker	Recommended Insert Grade	v _c Cutting Speed (sfm)	f Feed Rate (ipt) <Min.-Max.>			
						ø0.625"	ø0.75",ø1.000"	ø1.250"	ø1.500"
P	Steel, Carbon Steel A283 and similar Structural Steels	125	G	ACP300	390-790	0.002-0.004	0.002-0.004	0.002-0.004	0.002-0.005
	1015 Steel	125	L	ACP300	430-720	0.002-0.004	0.002-0.004	0.002-0.004	0.002-0.005
	1045 Steel	190	G	ACP300	330-660	0.003-0.008	0.003-0.008	0.003-0.009	0.004-0.009
	1045 Steel (Hardened)	250	G	ACP300	260-520	0.002-0.006	0.002-0.006	0.002-0.006	0.003-0.007
	1075 Steel	270	G	ACP300	330-520	0.003-0.007	0.003-0.007	0.003-0.008	0.004-0.009
	1075C Steel (Hardened)	300	G	ACP300	230-460	0.002-0.006	0.002-0.006	0.002-0.006	0.003-0.007
	Low Alloy Steel 4100, 4300 and 8600 Steels	180	L	ACP300	330-590	0.002-0.005	0.002-0.005	0.002-0.005	0.002-0.006
	4100, 4300 and 8600 Steels (Hardened)	275	G	ACP300	260-520	0.002-0.006	0.002-0.006	0.002-0.006	0.003-0.007
	4100, 4300 and 8600 Steels (Hardened)	300	G	ACP300	250-460	0.002-0.006	0.002-0.006	0.002-0.006	0.003-0.007
	4100, 4300 and 8600 Steels (Hardened)	350	G	ACP300	200-360	0.002-0.006	0.002-0.006	0.002-0.006	0.003-0.007
High Alloy Steel A2, D2 and other Tool and Die Steels	200	G	ACP300	330-520	0.003-0.008	0.003-0.008	0.003-0.009	0.004-0.009	
A2, D2 and other Tool and Die Steels (Hardened)	325	G	ACP300	260-390	0.002-0.006	0.002-0.006	0.002-0.006	0.003-0.007	
M	Stainless Steel 403 and other Martensitic and Ferritic Stainlesses	200	G	ACP300	330-590	0.002-0.006	0.002-0.006	0.002-0.006	0.003-0.007
	403 and other Martensitic Stainlesses (Hardened)	240	G	ACP300	300-490	0.002-0.006	0.002-0.006	0.002-0.006	0.003-0.007
	304, 316 and other Austenitic Stainlesses	180	G	ACP300	330-590	0.002-0.006	0.002-0.006	0.002-0.006	0.003-0.007
K	Cast Iron		H	ACK300	390-660	0.004-0.010	0.002-0.011	0.004-0.013	0.005-0.014
	Ductile Cast Iron		H	ACK300	300-490	0.004-0.010	0.002-0.011	0.004-0.013	0.005-0.014
S	Exotic Alloys (Heat Resistant Alloy, Super Alloy, Ti Alloy, etc.)	200	G	ACP300	80-230	0.002-0.006	0.002-0.006	0.002-0.006	0.003-0.007
N	Aluminium Alloy		G	DL1500	660-1050	0.002-0.007	0.002-0.007	0.002-0.007	0.003-0.008
	Copper Alloy		G	DL1500	590-920	0.002-0.007	0.002-0.007	0.002-0.007	0.003-0.008

Notes About Mounting Inserts (PDL type)

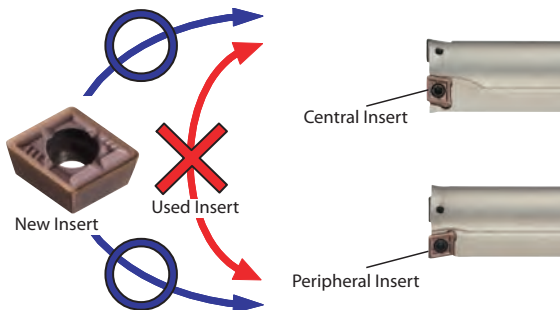

PDL type: Inserts can be used on either the centre or the outside.

Inserts used on the outside cannot be used in the center. Similarly, inserts used in the center cannot be used on the outside.

PCT type: 2 corners can be used only for the outer inserts.

Identification Information

PCT, PDL Type Identification

PCT 250 D3 S25

Tool Diameter
(ø25.0)

Max Depth L/D
(3D)

Shank Size
(ø25.0)

PCT, PDL Type Insert Identification

WDXT 07 35 06 -G

Width Across Flats
(7.5)

Thickness x
10 (3.5)

Corner Radius x
10 (R0.6)

Breaker
Type



Recommended Cutting Conditions PDL 4XD										
	Work Piece		Hardness HB	Recommended Breaker	Recommended Insert Grade	v _c Cutting Speed (sfm)	f Feed Rate (ipt) <Min.-Max.>			
							ø0.625"	ø0.75",ø1.000"	ø1.250"	ø1.500"
P	Steel, Carbon Steel	A283 and similar Structural Steels	125	G	ACP300	390-790	0.002-0.004	0.002-0.004	0.002-0.004	0.002-0.005
		1015 Steel	125	L	ACP300	430-720	0.002-0.004	0.002-0.004	0.002-0.004	0.002-0.005
		1045 Steel	190	G	ACP300	330-660	0.003-0.008	0.003-0.008	0.003-0.009	0.004-0.009
		1045 Steel (Hardened)	250	G	ACP300	260-520	0.002-0.006	0.002-0.006	0.002-0.006	0.003-0.007
		1075 Steel	270	G	ACP300	330-520	0.003-0.007	0.003-0.007	0.003-0.008	0.004-0.009
		1075C Steel (Hardened)	300	G	ACP300	230-460	0.002-0.006	0.002-0.006	0.002-0.006	0.003-0.007
	Low Alloy Steel	4100, 4300 and 8600 Steels	180	L	ACP300	330-590	0.002-0.005	0.002-0.005	0.002-0.005	0.002-0.006
		4100, 4300 and 8600 Steels (Hardened)	275	G	ACP300	260-520	0.002-0.006	0.002-0.006	0.002-0.006	0.003-0.007
		4100, 4300 and 8600 Steels (Hardened)	300	G	ACP300	250-460	0.002-0.006	0.002-0.006	0.002-0.006	0.003-0.007
		4100, 4300 and 8600 Steels (Hardened)	350	G	ACP300	200-360	0.002-0.006	0.002-0.006	0.002-0.006	0.003-0.007
High Alloy Steel	A2, D2 and other Tool and Die Steels	200	G	ACP300	330-520	0.003-0.008	0.003-0.008	0.003-0.009	0.004-0.009	
	A2, D2 and other Tool and Die Steels (Hardened)	325	G	ACP300	260-390	0.002-0.006	0.002-0.006	0.002-0.006	0.003-0.007	
M	Stainless Steel	403 and other Martensitic and Ferritic Stainlesses	200	G	ACP300	330-590	0.002-0.006	0.002-0.006	0.002-0.006	0.003-0.007
		403 and other Martensitic Stainlesses (Hardened)	240	G	ACP300	300-490	0.002-0.006	0.002-0.006	0.002-0.006	0.003-0.007
		304, 316 and other Austenitic Stainlesses	180	G	ACP300	330-590	0.002-0.006	0.002-0.006	0.002-0.006	0.003-0.007
K	Cast Iron			H	ACK300	390-660	0.004-0.010	0.002-0.011	0.004-0.013	0.005-0.014
		Ductile Cast Iron			H	ACK300	300-490	0.004-0.010	0.002-0.011	0.004-0.013
S	Exotic Alloys (Heat Resistant Alloy, Super Alloy, Ti Alloy, etc.)	200	G	ACP300	80-230	0.002-0.006	0.002-0.006	0.002-0.006	0.003-0.007	
N	Aluminium Alloy			G	DL1500	660-1050	0.002-0.007	0.002-0.007	0.002-0.007	0.003-0.008
		Copper Alloy			G	DL1500	590-920	0.002-0.007	0.002-0.007	0.002-0.007

Recommended Cutting Conditions PDL 5XD										
	Work Piece		Hardness HB	Recommended Breaker	Recommended Insert Grade	v _c Cutting Speed (sfm)	f Feed Rate (ipt) <Min.-Max.>			
							ø0.625"	ø0.75",ø1.000"	ø1.250"	ø1.500"
P	Steel, Carbon Steel	A283 and similar Structural Steels	125	G	ACP300	390-790	0.002-0.004	0.002-0.004	0.002-0.004	0.002-0.004
		1015 Steel	125	L	ACP300	430-720	0.002-0.003	0.002-0.003	0.002-0.003	0.002-0.004
		1045 Steel	190	G	ACP300	330-660	0.003-0.006	0.003-0.006	0.003-0.007	0.004-0.007
		1045 Steel (Hardened)	250	G	ACP300	260-520	0.002-0.004	0.002-0.004	0.002-0.005	0.002-0.006
		1075 Steel	270	G	ACP300	330-520	0.003-0.006	0.003-0.006	0.003-0.006	0.004-0.007
		1075C Steel (Hardened)	300	G	ACP300	230-460	0.002-0.004	0.002-0.004	0.002-0.005	0.002-0.005
	Low Alloy Steel	4100, 4300 and 8600 Steels	180	L	ACP300	330-590	0.002-0.004	0.002-0.004	0.002-0.004	0.002-0.004
		4100, 4300 and 8600 Steels (Hardened)	275	G	ACP300	260-520	0.002-0.004	0.002-0.004	0.002-0.005	0.002-0.005
		4100, 4300 and 8600 Steels (Hardened)	300	G	ACP300	250-460	0.002-0.004	0.002-0.004	0.002-0.005	0.002-0.005
		4100, 4300 and 8600 Steels (Hardened)	350	G	ACP300	200-360	0.002-0.004	0.002-0.004	0.002-0.005	0.002-0.005
High Alloy Steel	A2, D2 and other Tool and Die Steels	200	G	ACP300	330-520	0.003-0.006	0.003-0.006	0.003-0.007	0.004-0.007	
	A2, D2 and other Tool and Die Steels (Hardened)	325	G	ACP300	260-390	0.002-0.004	0.002-0.004	0.002-0.005	0.002-0.006	
M	Stainless Steel	403 and other Martensitic and Ferritic Stainlesses	200	G	ACP300	330-590	0.002-0.004	0.002-0.004	0.002-0.005	0.002-0.006
		403 and other Martensitic Stainlesses (Hardened)	240	G	ACP300	300-490	0.002-0.004	0.002-0.004	0.002-0.005	0.002-0.006
		304, 316 and other Austenitic Stainlesses	180	G	ACP300	330-590	0.002-0.004	0.002-0.004	0.002-0.005	0.002-0.006
K	Cast Iron			H	ACK300	390-660	0.003-0.008	0.004-0.009	0.004-0.010	0.004-0.011
		Ductile Cast Iron			H	ACK300	300-490	0.003-0.008	0.004-0.009	0.004-0.010
S	Exotic Alloys (Heat Resistant Alloy, Super Alloy, Ti Alloy, etc.)	200	G	ACP300	80-230	0.002-0.004	0.002-0.004	0.002-0.005	0.002-0.006	
N	Aluminium Alloy			G	DL1500	660-1050	0.002-0.006	0.002-0.006	0.002-0.006	0.002-0.007
		Copper Alloy			G	DL1500	590-920	0.002-0.006	0.002-0.006	0.002-0.006



• Characteristics



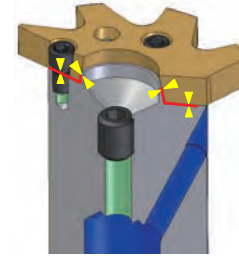

- Achieves efficiency through high speed, high feeding ability!! ($v_c=50$ to 200m/min , $f=0.4$ to 1.0mm/rev)
- Compatibility with a wide range of cutting conditions allows less strict cutting conditions and coolant control
- Minimal cut edge length design eliminates biting and tearing for improved quality and reliability
- Indexable cut edge design improves reliability of quality and life
- Cut edge diameters available from $\phi 11.9$ to $\phi 140.6\text{mm}$



- Easy insert replacement
- Flexible tool overhang lengths possible by combining the modular holder/arbors and holder with correction mechanism
- Can be used as a self-guiding tool with special guide pad holder

Positioning based on HSK taper has two points of contact with radial runout accuracy $< 4\ \mu\text{m}$ and face contact guarantees excellent power transmission

■ Application Examples

Tool Type					
Work					
Work Material	S50C or equivalent (260 to 310HB)	FC200 (190HB)	CK45 S50C or equivalent	AlMgSi17/FC200	FCD400
Bore ϕ (mm)	$\phi 17.017$	$\phi 25.159$	$\phi 24\text{ F7}$	$\phi 65\text{ H6}$	$\phi 32.984$
Surface Roughness max Ra/Rz	16	7	10	16	10
No. of Teeth	6	8	8	12	8
Lap Speed v_c (m/min)	250	23	127	120	320
Spindle Speed (min^{-1})	4,683	293	1,685	588	3,100
Feed Rate f_z (mm/t)	0.14	0.085	0.16	0.15	0.20
Feed Rate v_f (mm/min)	3,934	199	2,164	1,058	4,941
Depth of Cut a_p (mm/radius)	0.225	0.15	0.15	0.15	0.15
Wet/ Dry	Emulsion Type	Dry	Emulsion Type	Emulsion Type	MQL
Life, etc	1.25 efficiency	13,000 holes	7,500 pcs	160 pcs	90 Set



SumiReamer SR Type Configurations

①

Insert

- SRG Type (For Stop/Through Boring)
- SRL Type (For Through Boring)



Diameter : $\phi 11.900$ to $\phi 140.600\text{mm}$

Toolholder

- SRD Type (For Through Boring)
- SRB Type (For Stop Boring)

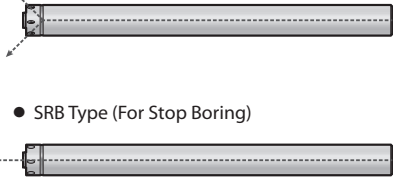

Applicable Diameter Range : $\phi 11.900$ to $\phi 35.600\text{mm}$
Shank Length : 100 to 274mm

Insert Run-Out Adjustment Mechanism

Arbor

- BT/A Type
- HSK Type

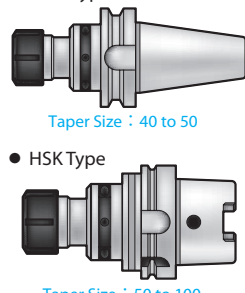

Taper Size : 40 to 50
Taper Size : 50 to 100

②

Head

- SRKG Type (For Through Boring)
- SRKB Type (For Stop Boring)

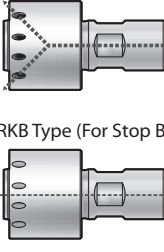

Applicable Diameter Range : $\phi 35.601$ to $\phi 140.600\text{mm}$
Head Length : 30 to 60mm

Insert Run-Out Adjustment Mechanism

Shank

- SRA Type

ZS(Cylindrical Shank) Type : ZS-20/25/32/40
WD(Weldon Shank) Type : WD-20/25/32/40
WN(Whistle Notch Shank) Type : WN-20/25/32/40

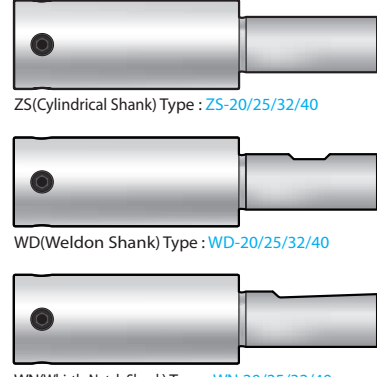

Applicable Diameter Range : $\phi 35.601$ to $\phi 140.600\text{mm}$
Shank Length : 80 to 160mm

Arbor

- BT/A Type
- HSK Type

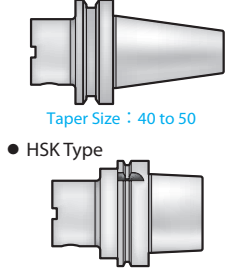

Taper Size : 40 to 50
Taper Size : 50 to 100

③

Head

- SRKG Type (For Through Boring)
- SRKB Type (For Stop Boring)

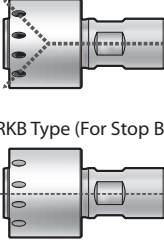

Applicable Diameter Range : $\phi 35.601$ to $\phi 140.600\text{mm}$
Head Length : 30 to 60mm

Insert Run-Out Adjustment Mechanism

Shank

- SRA Type

BM(Beta Module Shank) Type : BM-32/40/50/63

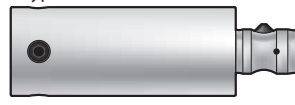

Applicable Diameter Range : $\phi 35.601$ to $\phi 140.600\text{mm}$
Shank Length : 80 to 160mm

Arbor

- BT/A Type
- HSK Type

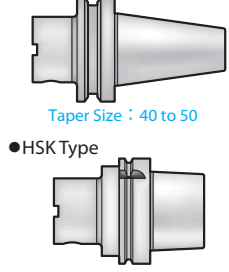

Taper Size : 40 to 50
Taper Size : 50 to 100

Check Sizes
When using a BM (Beta Module) type shank, choose a matching standard size.

Extensions

- B12 Type
- B13 Type

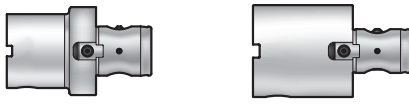

Shank Length : 40 to 75mm Shank Length : 35 to 180mm

Multiple extensions can be connected together
When connecting multiple extensions, it is recommended to consider rigidity and use longer shank sizes so that the total number of extensions is as low as possible.



Sumi Reamer SR Type Insert : SRG Type

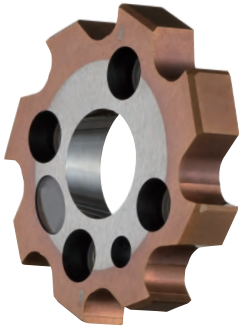

Fig 1

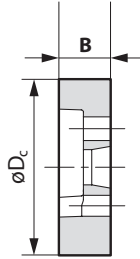
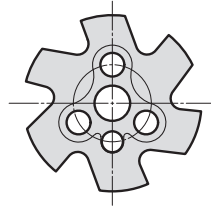
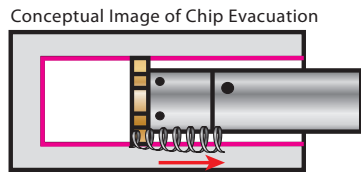
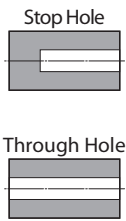
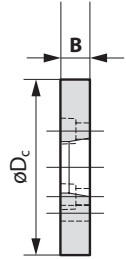
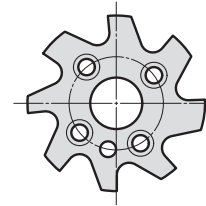
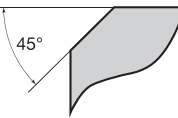

Fig 2



Chips Evacuated Toward Front

A01 Type



Standard Type

C01 Type

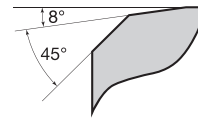

Emphasis on Surface Roughness

S02 Type

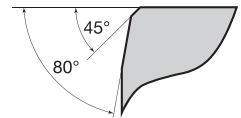

Emphasis on Direct Line

SR Type Inserts

Japan Stock Items (SRG Type)

Cat. No.	Stock	*iameter ϕ	Tolerance	Thickness B	No. of Teeth
SRG 12.0H7-A01-F0512R1	★	$\phi 12$	H7	4.3	6
SRG 13.0H7-A01-F0512R1	★	$\phi 13$	H7	4.3	6
SRG 14.0H7-A01-F0512R1	★	$\phi 14$	H7	4.3	6
SRG 15.0H7-A01-F0512R1	★	$\phi 15$	H7	4.3	6
SRG 16.0H7-A01-F0512R1	★	$\phi 16$	H7	4.3	6
SRG 17.0H7-A01-F0512R1	★	$\phi 17$	H7	4.3	6
SRG 18.0H7-A01-F0512R1	★	$\phi 18$	H7	4.3	6
SRG 19.0H7-A01-F0512R1	★	$\phi 19$	H7	4.3	6
SRG 20.0H7-A01-F0512R1	★	$\phi 20$	H7	4.3	6
SRG 21.0H7-A01-F0512R1	★	$\phi 21$	H7	4.3	6
SRG 22.0H7-A01-F0512R1	★	$\phi 22$	H7	4.3	6
SRG 23.0H7-A01-F0512R1	★	$\phi 23$	H7	4.3	6
SRG 24.0H7-A01-F0512R1	★	$\phi 24$	H7	4.3	8
SRG 25.0H7-A01-F0512R1	★	$\phi 25$	H7	4.3	8
SRG 26.0H7-A01-F0512R1	★	$\phi 26$	H7	4.3	8
SRG 27.0H7-A01-F0512R1	★	$\phi 27$	H7	4.3	8
SRG 28.0H7-A01-F0512R1	★	$\phi 28$	H7	4.3	8
SRG 29.0H7-A01-F0512R1	★	$\phi 29$	H7	4.3	8
SRG 30.0H7-A01-F0512R1	★	$\phi 30$	H7	4.3	8

Order Items (Made-to-order)

Diameter Range ϕD_c	Thickness B	No. of Teeth z	Order Number
$\phi 11.900$ to $\phi 15.600$	4.3	6	SRG... (See below)
$\phi 15.601$ to $\phi 18.600$	4.3	6	
$\phi 18.601$ to $\phi 23.600$	4.3	6	
$\phi 23.601$ to $\phi 28.600$	4.3	8	
$\phi 28.601$ to $\phi 35.600$	4.3	8	
$\phi 35.601$ to $\phi 43.600$	4.3	8	
$\phi 43.601$ to $\phi 51.600$	4.3	10	or SRL... (See below)
$\phi 51.601$ to $\phi 60.600$	4.3	10	
$\phi 60.601$ to $\phi 80.600$	4.3	12	
$\phi 80.601$ to $\phi 106.600$	4.3	12	
$\phi 106.601$ to $\phi 120.600$	5.3	12	
$\phi 120.601$ to $\phi 140.600$	5.3	12	

SRG (Special) and SRL (Special) are made-to-order items.

SR Type Reamer Insert Identification

Specifying Inserts Using Work Hole Diameter Tolerance

The actual desired reamer diameter will be on the upper limit side of the median work tolerance, and will differ depending on diameter/tolerance range/grade. Please contact us for details.

SR G 18.2 +20 -10 -A01 M1-F05 12R 1

- SR Type
- G = Straight, L = Lefthand helix
- Work Hole Diameter(mm)
- Tolerance (μm) +/- or standard (ex. H7)

- Approach Angle Code
- Nano Finishing
- Grade Symbol
- Coating Code
- Coating Thickness Code: 1 = Thin, 2 = Thick

Specifying Inserts Using Desired Reamer Diameter

By adding a "Q" after the diameter, it is possible to specify exact desired reamer dimensions. Uncoated types are available within $\pm 2\mu$, thin-layer coated types within $\pm 3\mu$, and thick-layer coated types within $\pm 4\mu$.

SR L 18.2 Q +3 -3 - A01 M1-F05 12R 1

- SR Type
- G = Straight, L = Lefthand helix
- Work Hole Diameter(mm)
- Tolerance (μm) +/-

- Approach Angle Code
- Nano finishing
- Grade Symbol
- Coating Code
- Coating Thickness Code: 1 = Thin, 2 = Thick



Sumi Reamer SR Type Insert : SRL Type



Fig 1

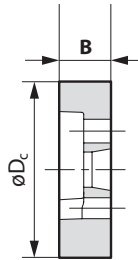
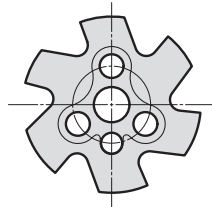
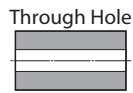
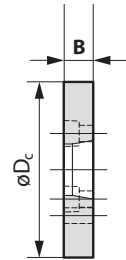
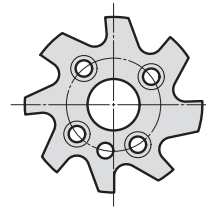
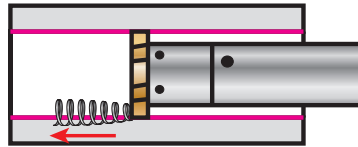

Fig 2



Conceptual Image of Chip Evacuation



Chips Evacuated Toward Back

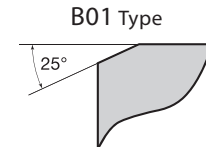

For Steel Through-Holes

SR Type Inserts

■ Japan Stock Items (SRL Type)

Cat. No.	Stock	*iameter ø*	Tolerance	Thickness B	No. of Teeth z
SRL 12.0H7-A01-F0512R1	★	ø12	H7	4.3	6
SRL 13.0H7-A01-F0512R1	★	ø13	H7	4.3	6
SRL 14.0H7-A01-F0512R1	★	ø14	H7	4.3	6
SRL 15.0H7-A01-F0512R1	★	ø15	H7	4.3	6
SRL 16.0H7-A01-F0512R1	★	ø16	H7	4.3	6
SRL 17.0H7-A01-F0512R1	★	ø17	H7	4.3	6
SRL 18.0H7-A01-F0512R1	★	ø18	H7	4.3	6
SRL 19.0H7-A01-F0512R1	★	ø19	H7	4.3	6
SRL 20.0H7-A01-F0512R1	★	ø20	H7	4.3	6
SRL 21.0H7-A01-F0512R1	★	ø21	H7	4.3	6
SRL 22.0H7-A01-F0512R1	★	ø22	H7	4.3	6
SRL 23.0H7-A01-F0512R1	★	ø23	H7	4.3	6
SRL 24.0H7-A01-F0512R1	★	ø24	H7	4.3	8
SRL 25.0H7-A01-F0512R1	★	ø25	H7	4.3	8
SRL 26.0H7-A01-F0512R1	★	ø26	H7	4.3	8
SRL 27.0H7-A01-F0512R1	★	ø27	H7	4.3	8
SRL 28.0H7-A01-F0512R1	★	ø28	H7	4.3	8
SRL 29.0H7-A01-F0512R1	★	ø29	H7	4.3	8
SRL 30.0H7-A01-F0512R1	★	ø30	H7	4.3	8

■ Recommended Cutting Conditions

(Min. - Max.)

ISO	Work Material	Helix	Adopted Grades	Grade	Depth of Cut a_p (mm/radius)			Cutting Speed v_c (m/min)	Feed Rate f_z (mm/t)
					Below ø20	ø20 to ø35	ø35 or more		
P	Carbon Steel	G (Straight)	F0512R1	Micro-Fine Grained Carbide + PVD	0.05 to 0.12	0.08 to 0.15	0.10 to 0.25	80 to 220	0.10 to 0.25
		L (Lefthand Helix)			0.05 to 0.12	0.08 to 0.15	0.10 to 0.25		
		G (Straight)	T1200A	Cermet	0.05 to 0.12	0.08 to 0.15	0.10 to 0.25	120 to 250	0.10 to 0.25
		L (Lefthand Helix)			0.05 to 0.12	0.08 to 0.15	0.10 to 0.25		
	Aloy Steel	G (Straight)	F0512R1	Micro-Fine Grained Carbide + PVD	0.05 to 0.12	0.08 to 0.15	0.10 to 0.25	60 to 180	0.06 to 0.20
		L (Lefthand Helix)			0.05 to 0.12	0.08 to 0.15	0.10 to 0.25		
Die Steel	Tool Steels	G (Straight)	F0512R1	Micro-Fine Grained Carbide + PVD	0.05 to 0.10	0.08 to 0.15	0.10 to 0.20	15 to 30	0.04 to 0.15
		L (Lefthand Helix)			0.05 to 0.12	0.08 to 0.15	0.10 to 0.25		
M	Stainless Steel	G (Straight)	F0512R1	Micro-Fine Grained Carbide + PVD	0.05 to 0.10	0.08 to 0.15	0.08 to 0.20	15 to 60	0.06 to 0.20
K	Cast Iron	G (Straight)	F0512R1	Micro-Fine Grained Carbide + PVD	0.05 to 0.18	0.08 to 0.20	0.10 to 0.25	80 to 250	0.10 to 0.30
N	Non-Ferrous Metal	G (Straight)	F0510C	Micro-Fine Grained Carbide + DLC	0.05 to 0.12	0.08 to 0.15	0.10 to 0.25	100 to 250	0.10 to 0.30



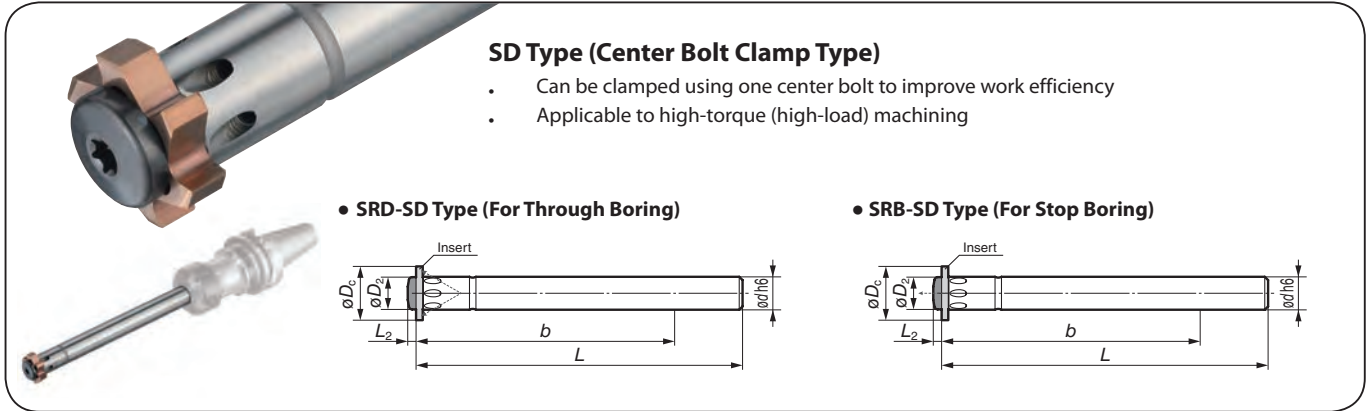

SD Type (Center Bolt Clamp Type)

- Can be clamped using one center bolt to improve work efficiency
- Applicable to high-torque (high-load) machining

• SRD-SD Type (For Through Boring)

• SRB-SD Type (For Stop Boring)

Steel Shank Toolholder SRD-SD/SRB-SD Series (Center Bolt Clamp Type)

■ Spare Parts

Diameter ϕD_c Range	Cat. No.				Dimensions(mm)					Cap Screw	Cap Screw	Wrench
	SRD Type (For Through Boring)		SRB Type (For Stop Boring)		ϕd	L	b	ϕD_2	L ₂			
	Cat. No.	Stock	Cat. No.	Stock								
Short	$\phi 11.900$ to $\phi 15.600$	SRD 16-10-100SD		SRB 16-10-100SD	10	100	60	9.8	2.5	C00-90-22	C00-90-22B	G00-20-27
	$\phi 15.601$ to $\phi 18.600$	19-12-115SD		19-12-115SD	12	115	70	11.8	3.0	C00-90-23	C00-90-23B	G00-20-28
	$\phi 18.601$ to $\phi 23.600$	24-16-128SD		24-16-128SD	16	128	80	15.8	4.0	C00-90-24	C00-90-24B	G00-20-29
	$\phi 23.601$ to $\phi 28.600$	29-20-145SD		29-20-145SD	20	145	95	15.8	4.0	C00-90-25	C00-90-25B	G00-20-29
	$\phi 28.601$ to $\phi 35.600$	36-25-170SD		36-25-170SD	25	170	120	24.5	4.0	C00-90-25	C00-90-25B	G00-20-29
Long	$\phi 11.900$ to $\phi 15.600$	SRD 16-10-160SD		SRB 16-10-160SD	10	160	120	9.8	2.5	C00-90-22	C00-90-22B	G00-20-27
	$\phi 15.601$ to $\phi 18.600$	19-12-185SD		19-12-185SD	12	185	140	11.8	3.0	C00-90-23	C00-90-23B	G00-20-28
	$\phi 18.601$ to $\phi 23.600$	24-16-208SD		24-16-208SD	16	208	160	15.8	4.0	C00-90-24	C00-90-24B	G00-20-29
	$\phi 23.601$ to $\phi 28.600$	29-20-240SD		29-20-240SD	20	240	190	15.8	4.0	C00-90-24	C00-90-24B	G00-20-29
	$\phi 28.601$ to $\phi 35.600$	36-25-274SD		36-25-274SD	25	274	224	24.5	4.0	C00-90-25	C00-90-25B	G00-20-29

Carbide Shank Toolholder SRD-SD/SRB-SD Series (Center Bolt Clamp Type)

■ Spare Parts

Diameter ϕD_c Range	Cat. No.				Dimensions(mm)					Cap Screw	Cap Screw	Wrench
	SRD Type (For Through Boring)		SRB Type (For Stop Boring)		ϕd	L	b	ϕD_2	L ₂			
	Cat. No.	Stock	Cat. No.	Stock								
Long	$\phi 11.900$ to $\phi 15.600$	SRD 16-10-160HMSD		SRB 16-10-160HMSD	10	160	120	9.8	2.5	C00-90-22	C00-90-22B	G00-20-27
	$\phi 15.601$ to $\phi 18.600$	19-12-185HMSD		19-12-185HMSD	12	185	140	11.8	3.0	C00-90-23	C00-90-23B	G00-20-28
	$\phi 18.601$ to $\phi 23.600$	24-16-208HMSD		24-16-208HMSD	16	208	160	15.8	4.0	C00-90-24	C00-90-24B	G00-20-29
	$\phi 23.601$ to $\phi 28.600$	29-20-240HMSD		29-20-240HMSD	20	240	190	15.8	4.0	C00-90-24	C00-90-24B	G00-20-29
	$\phi 28.601$ to $\phi 35.600$	36-25-274HMSD		36-25-274HMSD	25	274	224	24.5	4.0	C00-90-25	C00-90-25B	G00-20-29



Important Notes About SD Type (Center Bolt Clamp Type)

This product can be used for both through-hole and Blind-hole drilling. However, the head of the center bolt protrudes from the end of the body. Therefore, ensure clearance by referring to the protrusion amount of the center bolt (L₂) shown in the dimension table.

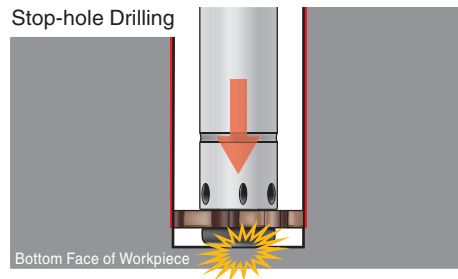
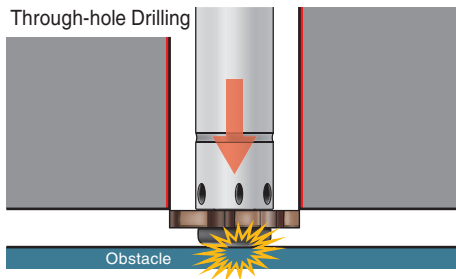

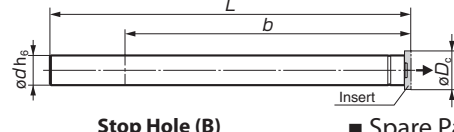
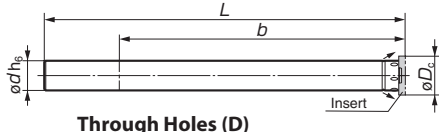

■ Insert Holder

Through Holes (D)

Stop Hole (B)

■ Spare Parts

	Reamer Diameter ϕD_c Range	Cat. No.				Dimensions		Cap Screw		Wrench		
		Through Holes (D)		Stop Hole (B)		Carbide Shank SRD Type	Carbide Shank SRB Type	ϕd	L	ϕd		
		Cat. No.	Stock	Cat. No.	Stock	Cat. No.	Stock	Cat. No.	Stock			
Short	$\phi 11.900$ to $\phi 15.600$	SRD 16-10-100	★	SRB 16-10-100	★			10	100	60	C00-90-00-(3x)	G00-20-01
	$\phi 15.601$ to $\phi 18.600$	SRD 19-12-115	★	SRB 19-12-115	★			12	115	70	C00-90-00-(3x)	G00-20-01
	$\phi 18.601$ to $\phi 23.600$	SRD 24-16-128	★	SRB 24-16-128	★			16	128	80	C00-90-01-(3x)	G00-20-02
	$\phi 23.601$ to $\phi 28.600$	SRD 29-20-145	★	SRB 29-20-145	★			20	145	95	C00-90-01-(4x)	G00-20-02
	$\phi 28.601$ to $\phi 35.600$	SRD 36-25-170	★	SRB 36-25-170	★			25	170	120	C00-90-01-(4x)	G00-20-02
Long	$\phi 11.900$ to $\phi 15.600$	SRD 16-10-160		SRB 16-10-160		SRD 16-10-160HM	SRB 16-10-160HM	10	160	120	C00-90-00-(3x)	G00-20-01
	$\phi 15.601$ to $\phi 18.600$	SRD 19-12-185		SRB 19-12-185		SRD 19-12-185HM	SRB 19-12-185HM	12	185	140	C00-90-00-(3x)	G00-20-01
	$\phi 18.601$ to $\phi 23.600$	SRD 24-16-208		SRB 24-16-208		SRD 24-16-208HM	SRB 24-16-208HM	16	208	160	C00-90-01-(3x)	G00-20-02
	$\phi 23.601$ to $\phi 28.600$	SRD 29-20-240		SRB 29-20-240		SRD 29-20-240HM	SRB 29-20-240HM	20	240	190	C00-90-01-(4x)	G00-20-02
	$\phi 28.601$ to $\phi 35.600$	SRD 36-25-274		SRB 36-25-274		SRD 36-25-274HM	SRB 36-25-274HM	25	274	224	C00-90-01-(4x)	G00-20-02



■ SRK Type

SRKG Type
(For Through Boring)

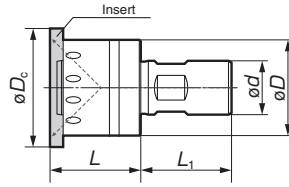

SRKB Type
(For Stop Boring)

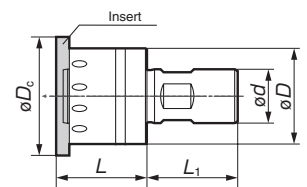

■ Insert Holder (Head)

■ Spare Parts

Reamer Diameter ϕD_c Range	Cat. No.				Dimensions				Cap Screw		Wrench		Cap Screw		Wrench	
	SKRG Type		SRKB Type		D	d	L	L ₁	(1)	(2)	(3)	(4)				
	Cat. No.	Stock	Cat. No.	Stock												
$\phi 35.601$ to $\phi 43.600$	SRKG 44-32-18-030		SRKB 44-32-18-030		32	18	30	30	C00-90-02-(4x)	G00-20-02	C00-26-23	G00-02-07				
$\phi 43.601$ to $\phi 51.600$	SRKG 52-39-20-035		SRKB 52-39-20-035		39	20	35	30	C00-90-02-(5x)	G00-20-02	C00-26-38	G00-02-07				
$\phi 51.601$ to $\phi 60.600$	SRKG 61-46-25-040		SRKB 61-46-25-040		46	25	40	35	C00-90-02-(5x)	G00-20-02	C00-24-26	G00-02-08				
$\phi 60.601$ to $\phi 80.600$	SRKG 81-56-32-050		SRKB 81-56-32-050		56	32	50	40	C00-90-04-(4x)	G00-20-03	C00-26-37	G00-02-09				
$\phi 80.601$ to $\phi 100.600$	SRKG 101-76-40-060		SRKB 101-76-40-060		76	40	60	50	C00-90-04-(4x)	G00-20-03	C00-24-31	G00-02-16				
$\phi 100.601$ to $\phi 120.600$	SKRG 121-76-40-060		SKRB 121-76-40-060		76	40	60	50	C00-90-04-(4x)	G00-20-03	C00-24-31	G00-02-16				
$\phi 120.601$ to $\phi 140.600$	SKRG 121-76-40-060		SKRB 121-76-40-060		76	40	60	50	C00-90-04-(4x)	G00-20-03	C00-24-31	G00-02-16				

■ SRA Type

BM (Beta Module Shank) Type

ZS (Cylindrical Shank) Type

WD (Weldon Shank) Type

WN (Whistle Notch Shank) Type

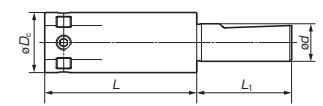
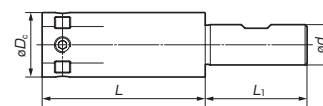
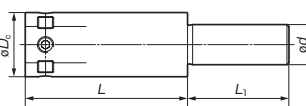
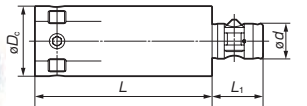

■ Holder (with diameter correction mechanism)

■ Spare Parts

Reamer Diameter ϕD_c Range	Cat. No.		Dimensions				Cap Screw		Wrench		Clamp		Screw						
	Through Holes (D)		D	d	L	L ₁	(1)	(2)	(3)	(4)									
	Cat. No.	Stock																	
$\phi 35.601$ to $\phi 43.600$	SRA 44-32-BM32-080		32	BM-32	80	8.5	C00-90-08-(4x)	G00-02-05	Z00-32-21	Z00-32-23									
	SRA 44-32-ZS20-080			ZS-20															
	SRA 44-32-WD20-080			WD-20															
	SRA 44-32-WN20-080			WN-20															
$\phi 43.601$ to $\phi 51.600$	SRA 52-39-BM40-100		39	BM-40	100	26	C00-90-10-(4x)	G00-02-06	Z00-40-21	Z00-40-23									
	SRA 52-39-ZS25-100			ZS-25															
	SRA 52-39-WD25-100			WD-25															
	SRA 52-39-WN25-100			WN-25															
$\phi 51.601$ to $\phi 60.600$	SRA 61-46-BM50-120		46	BM-50	120	31	C00-90-10-(4x)	G00-02-06	Z00-50-21	Z00-50-23									
	SRA 61-46-ZS32-120			ZS-32															
	SRA 61-46-WD32-120			WD-32															
	SRA 61-46-WN32-120			WN-32															
$\phi 60.601$ to $\phi 80.600$	SRA 81-56-BM50-140		56	BM-50	140	31	C00-90-12-(4x)	G00-02-07	Z00-50-21	Z00-50-23									
	SRA 81-56-BM50-080			BM-50							80								
	SRA 81-56-ZS40-140			ZS-40							140								
	SRA 81-56-ZS40-080			ZS-40							80								
	SRA 81-56-WD40-140			WD-40							140								
	SRA 81-56-WD40-080			WD-40							80								
	SRA 81-56-WN40-140			WN-40							140								
SRA 81-56-WN40-080		WN-40	80																
$\phi 80.601$ to $\phi 140.600$	SRA 101-76-BM63-160		76	BM-63	160	31	C00-90-16-(4x)	G00-02-08	Z00-63-21	Z00-63-23									
	SRA 101-76-BM63-100			BM-63							100								
	SRA 101-76-ZS40-100			ZS-40							160								
	SRA 101-76-ZS40-160			ZS-40							100								
	SRA 101-76-WD40-160			WD-40							160								
	SRA 101-76-WD40-100			WD-40							100								
	SRA 101-76-WN40-160			WN-40							160								
SRA 101-76-WN40-100		WN-40	100																



SUMIREAMER SR SERIES

Indexable Reamers



■ B12 Type

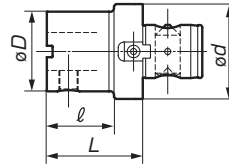

■ B13 Type

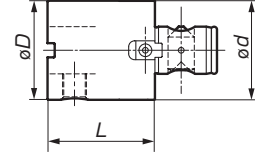

■ Extensions

Cat. No.	øD	ød	L	I	Weight (kg)
B12-32-25-040	25	32	40	25	0.2
B12-40-25-040	25	42	40	25	0.3
32-045	32	42	45	30	0.3
B12-50-40-050	42	50	50	35	0.5
B12-63-25-045	25	63	45	25	0.7
32-050	32	63	50	30	0.9
40-055	42	63	55	35	1.1
B12-80-40-060	42	80	60	35	2.2
63-060	63	80	60	35	2.4
B12-100-40-060	42	100	60	35	3.1
63-060	63	100	60	35	3.3
80-075	80	100	75	50	3.5

Cat. No.	øD	ød	L	I	Weight (kg)
B13-25-25-045	25	25	45	-	0.2
070	25	25	70	-	0.3
B13-32-32-035	32	32	35	-	0.2
070	32	32	70	-	0.4
B13-40-40-045	42	42	45	-	0.4
070	42	42	70	-	0.7
B13-50-50-065	50	50	65	-	1.0
100	50	50	100	-	1.5
B13-63-63-060	63	63	60	-	1.3
125	63	63	125	-	2.9
B13-80-80-080	80	80	80	-	2.9
160	80	80	160	-	4.9
B13-100-100-080	100	100	80	-	4.9
180	100	100	180	-	10.9

■ Adapters

Adapters	SR Parameter	□	D	L	ℓ	kg	Product Code
DIN69871-A/D	SR044	40	32	65	46	1.1	SRAD10 40A 44 065
	SR052	40	39	65	46	1.2	SRAD10 40A 52 065
	SR061	40	46	75	56	1.4	SRAD10 40A 61 075
	SR081	40	56	80	61	1.6	SRAD10 40A 81 080
	SR101-SR141	40	76	95	76	2.2	SRAD10 40A 101 095
	SR044	50	32	65	46	2.9	SRAD10 50A 44 065
	SR052	50	39	65	46	3	SRAD10 50A 52 065
	SR061	50	46	75	56	3.2	SRAD10 50A 61 075
	SR081	50	56	80	61	3.6	SRAD10 50A 81 080
	SR101-SR142	50	76	95	76	4.6	SRAD10 50A 101 095
	DIN69871-B	SR044	40	32	65	46	1.1
SR052		40	39	65	46	1.2	SRAD10 40B 52 065
SR061		40	46	75	56	1.4	SRAD10 40B 61 075
SR081		40	56	80	61	1.6	SRAD10 40B 81 080
SR101-SR142		40	76	95	76	2.2	SRAD10 40B 101 095
SR044		50	32	65	46	2.9	SRAD10 50B 44 065
SR052		50	39	65	46	3	SRAD10 50B 52 065
SR061		50	46	75	56	3.2	SRAD10 50B 61 075
SR081		50	56	80	61	3.6	SRAD10 50B 81 080
SR101-SR143		50	76	95	76	4.6	SRAD10 50B 101 095
MAS-BT/A		SR044	40	32	65	33	1.1
	SR052	40	39	65	38	1.3	SRAT10 40A 52 065
	SR061	40	46	75	43	1.4	SRAT10 40A 61 070
	SR081	40	56	80	53	1.7	SRAT10 40A 81 080
	SR101-SR143	40	76	95	-	2.5	SRAT10 40A 101 095
	SR044	50	32	65	27	3.7	SRAT10 50A 44 060
	SR052	50	39	65	27	3.8	SRAT10 50A 52 065
	SR061	50	46	75	37	4	SRAT10 50A 61 070
	SR081	50	56	80	47	4.3	SRAT10 50A 81 080
	SR101-SR144	50	76	95	57	5.1	SRAT10 50A 101 095
	DIN698893-HSK-A	SR044	63	32	85	59	1
SR052		63	39	90	64	1.2	SRAH10 63A 52 090
SR061		63	46	100	74	1.5	SRAH10 63A 61 100
SR081		63	56	105	79	1.8	SRAH10 63A 81 105
SR101-SR144		63	76	120	94	2.4	SRAH10 63A 101 120
SR044		100	32	85	61	2.3	SRAH10 100A 44 090
SR052		100	39	90	66	2.6	SRAH10 100A 52 095
SR061		100	46	100	71	2.8	SRAH10 100A 61 100
SR081		100	56	105	91	3.5	SRAH10 100A 81 120
SR101-SR142		100	76	120	101	5	SRAH10 100A 101 130

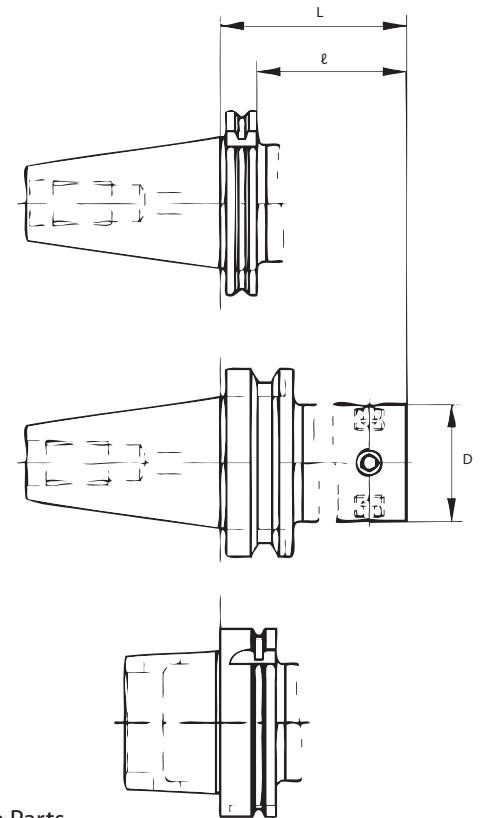

■ Spare Parts

SR Parameter	Screw	Wrench
SR044	C00 90 08 (4x)	G00 02 05
SR052	C00 90 10 (4x)	G00 02 06
SR061	C00 90 10 (4x)	G00 02 06
SR081	C00 90 12 (4x)	G00 02 07
SR101 - SR141	C00 90 16 (4x)	G00 02 08



■ Arbor BETA Module

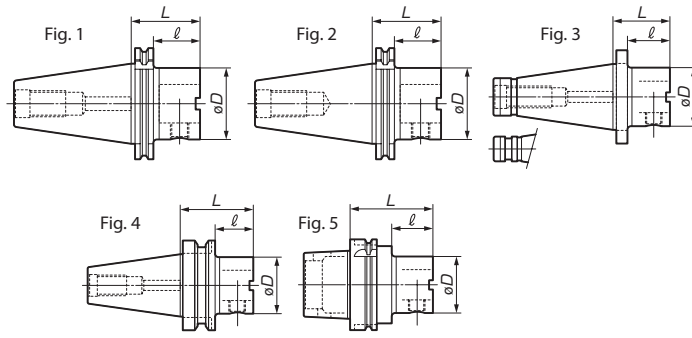

■ DIN 69871-A/D

Cat. No.	Stock	BETA No.	Taper Size	L	ℓ	D	kg	MCC	Fig.
BD10-40A-25-050		25	40	50	31	25	0.8	B25	1
BD10-40A-32-050		32	40	50	31	35	0.9	B32	
BD10-40A-40-035		40	40	35	16	42	0.9	B40	
BD10-40A-40-050		40	40	50	31	42	1.1	B40	
BD10-40A-63-065		63	40	65	46	63	1.5	B63	
BD10-40A-50-050		50	40	50	31	50	1.2	B50	
BD10-40A-63-090		63	40	90	70	63	2.0	B63	
BD10-50A-25-060		25	50	60	41	25	2.8	B25	
BD10-50A-32-060		32	50	60	41	32	2.9	B32	
BD10-50A-40-060		40	50	60	41	42	3.0	B40	
BD10-50A-50-060		50	50	60	41	50	3.2	B50	
BD10-50A-63-060		63	50	60	41	63	3.3	B63	
BD10-50A-80-070		80	50	70	51	80	4.0	B80	
BD10-50A-100-115		100	50	115	96	100	6.9	B100	

■ MAS-BT/A

Cat. No.	Stock	BETA No.	Taper Size	L	ℓ	D	kg	MCC	Fig.
BT10-40A-25-060		25	40	60	33	25	0.8	B25	4
BT10-40A-32-060		32	40	60	33	32	0.9	B32	
BT10-40A-40-028		40	40	28	1	42	0.9	B40	
BT10-40A-40-060		40	40	60	33	42	1.2	B40	
BT10-40A-50-060		50	40	60	33	50	1.3	B50	
BT10-40A-63-055		63	40	55	28	63	1.4	B63	
BT10-40A-63-070		63	40	70	43	63	1.7	B63	
BT10-50A-32-070		32	50	70	32	32	3.7	B32	
BT10-50A-40-070		40	50	70	32	42	3.9	B40	
BT10-50A-50-070		50	50	70	32	50	4.1	B50	
BT10-50A-63-080		63	50	80	42	63	4.3	B63	
BT10-50A-80-100		80	50	100	62	80	5.5	B80	
BT10-50A-100-110		100	50	110	72	100	7.0	B100	

■ DIN 69871-B

Cat. No.	Stock	BETA No.	Taper Size	L	ℓ	D	kg	MCC	Fig.
BD10-40B-25-050		25	40	50	31	25	0.8	B25	2
BD10-40B-32-050		32	40	50	31	35	0.9	B32	
BD10-40B-40-035		40	40	35	16	42	0.9	B40	
BD10-40B-40-050		40	40	50	31	42	1.1	B40	
BD10-40B-50-065		50	40	50	31	50	1.2	B50	
BD10-40B-63-050		63	40	65	46	63	1.5	B63	
BD10-40B-63-090		63	40	90	70	63	2.0	B63	
BD10-50B-25-060		25	50	60	41	25	2.8	B25	
BD10-50B-32-060		32	50	60	41	32	2.9	B32	
BD10-50B-40-060		40	50	60	41	42	3.0	B40	
BD10-50B-50-060		50	50	60	41	50	3.2	B50	
BD10-50B-63-060		63	50	60	41	63	3.3	B63	
BD10-50B-80-070		80	50	70	51	80	4.0	B80	
BD10-50B-100-115		100	50	115	96	100	6.9	B100	

■ DIN 69893-A HSK (Coolant tube sold separately.)

Cat. No.	Stock	BETA No.	Taper Size	L	ℓ	D	kg	MCC	Fig.
BH10-50A-25-055		25	50	55	29	25	0.5	B25	5
BH10-50A-32-060		32	50	60	34	32	0.6	B32	
BH10-50A-40-065		40	50	65	39	42	0.7	B40	
BH10-63A-25-055		25	63	55	29	25	0.9	B25	
BH10-63A-32-060		32	63	60	34	32	1.0	B32	
BH10-63A-40-065		40	63	65	23	42	1.1	B40	
BH10-63A-50-070		50	63	70	44	50	1.5	B50	
BH10-63A-63-080		63	63	80	38	63	1.5	B63	
BH10-100A-40-080		40	100	80	35	42	2.3	B40	
BH10-100A-50-080		50	100	80	35	50	2.5	B50	
BH10-100A-63-080		63	100	80	35	63	2.8	B63	
BH10-100A-80-090		80	100	90	45	80	3.8	B80	
BH10-100A-100-100		100	100	100	55	100	4.0	B100	

■ ISO-DIN 2080

Cat. No.	Stock	BETA No.	Taper Size	L	ℓ	D	kg	MCC	Fig.
BI10-40-40-035		40	40	35	23	42	0.7	B40	3
BI10-40-40-050		40	40	50	38	42	1.1	B40	
BI10-40-63-070		63	40	70	58	63	1.8	B63	
BI10-50-40-060		40	50	60	45	42	3.0	B40	
BI10-50-63-060		63	50	60	45	63	3.5	B63	
BI10-50-100-100		100	85	100	85	100	6.8	B100	

Polygon Shank Holders

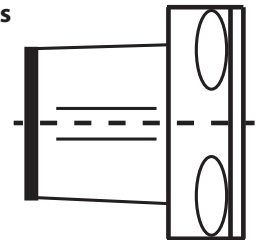

■ Spare Parts

Clamp BETA No.	
25	Z00-25-24
32	Z00-32-24
40	Z00-40-24
63	Z00-63-24
80	Z00-80-24
100	Z00-100-24

■ Coolant Tubes

Taper Size	
50	H00-50-01
63	H00-63-01
100	H00-100-01

■ Polygon Shank Hydraulic Holders

Style	Stock	d	L	kg
PSC40		ø12	81	0.7
PSC40		ø20	-	-
PSC40		ø32	-	-
PSC50		ø12	85	0.9
PSC50		ø20	90	1.05
PSC50		ø32	-	-
PSC63		ø12	87	1.3
PSC63		ø20	97	1.6
PSC63		ø32	110	2.8

All Polygon Shank Holders available upon request



SUMIREAMER SR SERIES

Indexable Reamers

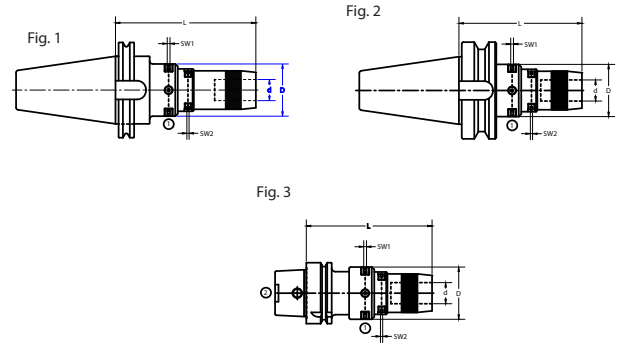
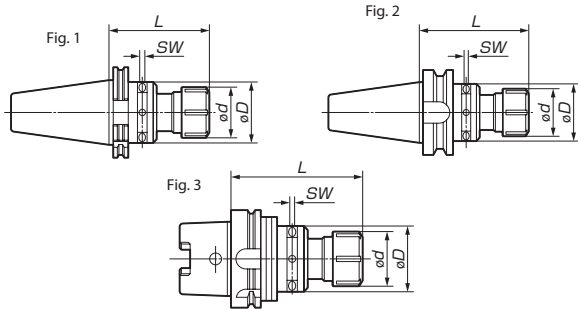

■ Compensation Collet- Chuck

Product Code	Size	Range	d	D	L	SW
DIN69871 AD/B Fig. 1						
AND60 40A 32 120	40 ER32	3.0 - 20.0	50	76	120	5
AND60 40A 40 135	40 ER40	3.0 - 26.0	63	76	135	5
AND60 50A 32 120	50 ER32	3.0 - 20.0	50	76	120	5
AND60 50A 40 135	50 ER40	3.0 - 26.0	63	76	135	5
MAS-BT/A Fig. 2						
ANT60 40A 32 120	40 ER32	3.0 - 20.0	50	76	120	5
ANT60 40A 40 135	40 ER40	3.0 - 26.0	63	76	135	5
ANT60 50A 32 120	50 ER32	3.0 - 20.0	50	76	120	5
ANT60 50A 40 135	50 ER40	3.0 - 26.0	63	76	135	5
DIN69893-HSK-A Fig. 3						
ANT60 63A 32 120	63 ER32	3.0 - 20.0	50	76	120	5
ANT60 63A 40 135	63 ER40	3.0 - 26.0	63	76	135	5
ANT60 100A 32 120	100 ER32	3.0 - 20.0	50	76	120	5
ANT60 100A 40 165	100 ER40	3.0 - 26.0	63	76	135	5

■ Hyrdo- Compensation Chuck

Product Code	d	D	L	SW ₁	SW ₂
DIN69871 AD/B Fig. 1					
AND65 40A 12 135	40	12	76	135	5
AND65 40A 20 135	40	20	69	135	5
AND65 40A 32 180	40	32	88	180	6
AND65 50A 12 160	50	12	76	160	5
AND65 50A 20 160	50	20	69	160	5
AND65 50A 32 180	50	32	88	180	6
MAS-BT/A Fig. 2					
ANT65 40A 12 135	40	12	76	135	5
ANT65 40A 20 135	40	20	69	135	5
ANT65 40A 32 180	40	32	88	180	6
ANT65 50A 12 135	50	12	76	135	5
ANT65 50A 20 135	50	20	69	135	5
ANT65 50A 32 180	50	32	88	180	6
DIN69893-HSK-A Fig. 3					
ANH65 63A 12 135	63	12	76	135	5
ANH65 63A 20 135	63	20	69	135	5
ANH65 63A 32 180	63	32	88	180	6
ANH65 100A 12 135	100	12	76	135	5
ANH65 100A 20 135	100	20	69	135	5
ANH65 100A 32 165	100	32	88	165	6

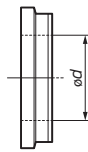
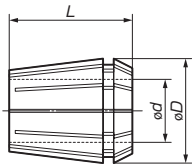

■ Collet

Cat. No.	Size	øD	L
62-25-□□	ER25	26	35
62-32-□□	ER32	33	40
62-40-□□	ER40	41	46

□□ = ød

Ex. 1: ER25, d=12 ⇒ 62 25 12

These items are in stock in increments of 1 mm:

62-25-□□ from ø12 to ø16 mm

62-32-□□ from ø12 to ø20 mm

62-40-□□ from ø12 to ø26 mm.

■ Seal Disc

Cat. No.	Size	ød
20.107.41-□□□	ER25	3.0 to 16.0
20.107.51-□□□	ER32	3.0 to 20.0
20.107.61-□□□	ER40	3.0 to 26.0

□□□ = ød

Ex. 1: ER25, d=12 ⇒ 20.107.41 120

These items are in stock in increments of 1 mm:

20.107.41-□□□ from ø12 to ø16 mm

20.107.51-□□□ from ø12 to ø20 mm

20.107.61-□□□ from ø12 to ø26 mm.

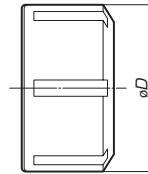

■ Collet Cap

Cat. No.	Size	D	ød
20.107.410	ER25	42	M32 x 1.5
20.107.510	ER32	50	M40 x 1.5
20.107.610	ER40	63	M50 x 1.5

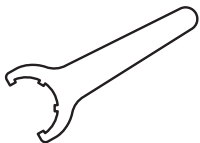

■ Tightening Wrench

Cat. No.	Size
00-05-05	ER25
00-05-02	ER32
00-05-03	ER40



■ Torque Wrench

Wrench Cat. No.	Applicable Holder	Torx Hole	Torque Rating
G00-40-11	SR □ 16 / SR □ 19	T 6	0.9Nm
G00-40-12	SR □ 24 to SR □ 61	T 8	1.5Nm
G00-40-13	SR □ 81 / SR □ 101	T 15	3.5Nm

■ Coolant Tubes

Taper Size	
40	H00-40-01
63	H00-63-01
100	H00-100-01

■ Spare Parts

C00-96-16



■ SR Type Reamer Usage Instructions (Adjusting runout)

The runout at the cut edge of a reamer should be zero to obtain optimum boring precision. To correct runout in the holder or the machine's spindle, use of holders with a correction mechanism, hydro chucks, and shrink-fitting is recommended. Various methods can be used to measure runout on an SR type reamer. SR type reamers offer good runout repeatability so it is recommended that inserts be replaced without removing the shank holder from the spindle.

(1) High-accurate cutting edge runout measurement method (for measuring the arc land on the insert)

Measuring the lands immediately after the outer diameter of the insert has been chamfered eliminates all attachment errors. This allows for the most accurate runout measurement.



(2) Simplified measurement method (for measuring the short taper of the holder)

The short taper on the holder where the inserts are attached provides the easiest and most accurate measurement before attaching the inserts.



(3) Simplified measurement method (for measuring the outer diameter of the holder)

The high precision machined outer diameter of the shank holder provides a good estimate of the runout measurement.



* Runout accuracy is higher in order of (1), (2) and (3).

■ Shank Holders with Correction Mechanism

Shank holders must have a correction mechanism when using reamers of $\varnothing 35$ mm or larger. (Adjustment procedure)

- (1) Tighten the centre locking screw to torque value A in the table below, then attach the insert and measure the runout of the cut edge.
- (2) Verify the tooth where runout peaks and adjust with the adjustment screw.
- (3) Repeat this adjustment for each tooth as necessary.
- (4) Remove the adjusted insert, tighten the centre locking screw to torque value B in the table below, then re-attach the insert.

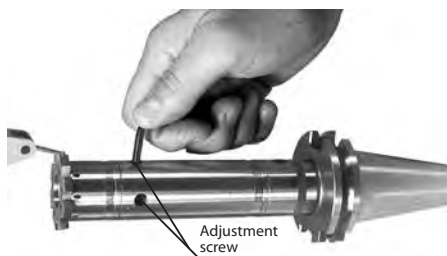



Recommended Tightening Torque for Center Locking Screw (N·m)

Size	A	B
SR044	25	32
SR052	25	32
SR061	40	55
SR081	65	85
SR101	95	120

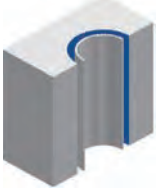
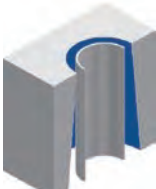
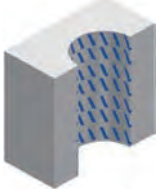
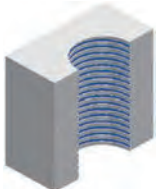

■ Troubleshooting for Drilling

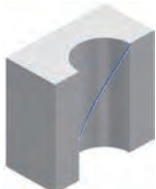
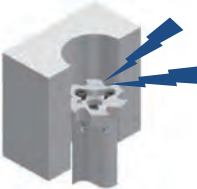
Failure	Countermeasures
<p>Large Hole Diameter</p> 	<ul style="list-style-type: none"> -Reduce the run-out as much as possible (use a holder with a diameter correction mechanism). -Decrease the cutting speed. -Increase the feed rate. -Increase the coolant concentration. -Reduce the machining allowance. -Check the cutting edge for damage (the existence of built-up edges). -Change the reamer diameter.
<p>Tapered Hole</p> 	<ul style="list-style-type: none"> -Reduce the run-out as much as possible (use a holder with a diameter correction mechanism). -Decrease the cutting speed. -Decrease the feed rate. -Adjust the coolant concentration. -Review the pre-machining process. -Review the clamping method of the workpiece. -Compare the hole size between when the workpiece is clamped and unclamped. -Check and correct the direction of chip evacuation.
<p>Chatter Mark on Machined Surface</p> 	<ul style="list-style-type: none"> -Reduce the run-out as much as possible (use a holder with a diameter correction mechanism). -Change the approach angle of the insert cutting edge. -Review the clamping method of the workpiece. -Decrease the cutting speed. -Increase the feed rate.
<p>Poor Surface Roughness</p> 	<ul style="list-style-type: none"> -Check the cutting edge for damage. -Reduce the run-out as much as possible (use a holder with a diameter correction mechanism). -Check whether the cutting conditions are within the recommended range. -Change to internal coolant supply. -Increase the coolant concentration.

Failure	Countermeasures
<p>Return Mark</p> 	<ul style="list-style-type: none"> -Reduce the run-out as much as possible (use a holder with a diameter correction mechanism). -Check the cutting edge for damage (the existence of built-up edges). -Reduce the machining allowance. -Change to an insert with a sharper cutting edge. -Decrease the return (lifting) feed.
<p>Irregular Cutting Noise</p> 	<ul style="list-style-type: none"> -Decrease the coolant concentration. -Increase the machining allowance. -Check the cutting edge for damage. -Change the approach angle of the insert cutting edge.
<p>Small Hole Diameter</p> 	<ul style="list-style-type: none"> -Replace the insert. -Decrease the coolant concentration. -Increase the machining allowance. -Increase the cutting speed. -Decrease the feed rate.

A.L.M.T. PRODUCTS

Pages 527-538



ALMT
Products

ALMT PRODUCTS

PAGES

Ultra Precision Cutting Tools 527-531

PCD Reamers 532-538



Ultra Precision Cutting Tools

Nano/Microforming Tools **UPC**



A.L.M.T. Corp., as a leading manufacturer of ultra-precision diamond cutting tools offers a broad range of nano- and micro-forming cutting tools to satisfy market needs.

Our many years of experience and know-how has provided us with a comprehensive understanding of the optimal physical properties of monocrystal diamond. Our state-of-the-art development process yields the highest precision in tool edge measurement. As a result, our diamond cutting tools achieve high-precision microscopic cutting in workpieces with nanometer requirements.

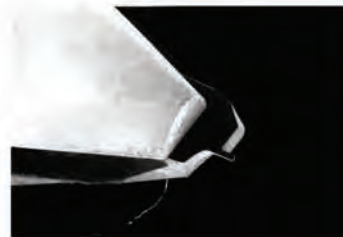

Extremely sharp cutting edge with the advanced UPC



Checking the variation in the distance between carbon atoms in monocrystal diamond assists in determining the optimal crystal orientation

The pursuit of producing nanometer accurate diamond cutting tools begins with the selection of optimal monocrystal diamond. Although it is known that the lattice constant of diamond is 3.5667Å the distance between the crystal planes in monocrystal diamond varies, causing contamination or divisibility. Therefore, it is very important to select the best diamond ore and determine the optimal crystal orientation based on the application.

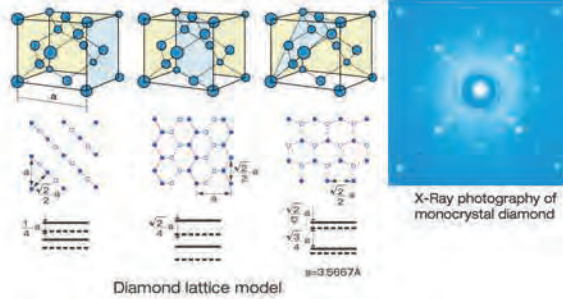

Tool edge polishing technologies used for profiling under nanometer tolerances

In order to accurately produce nanometer-controlled movement on a workpiece, a cutting tool requires a sharp tool edge capable of producing nanometer-size chips, in addition to high contour precision. We have achieved this using our unique polishing and measurement technologies.

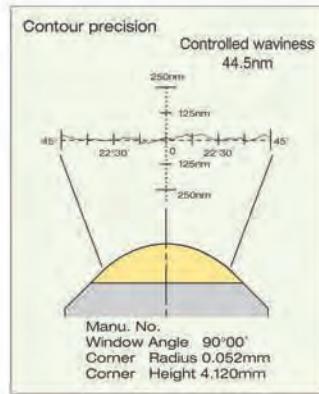

Contour inspection sheet

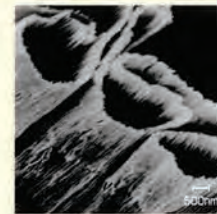
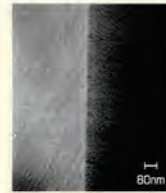

Straightness and surface roughness unobtainable with photolithography or ion-beam method

With their extremely sharp cutting edge, the UPC-Nano series developed by A.L.M.T. Corp. achieves excellent surface roughness and straightness, which cannot be obtained using photolithography or ion-beam methods. They are also effective tools in high aspect-ratio applications where micrometer precision is required.

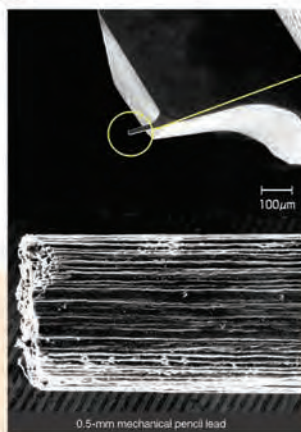

Polished surface shown in the same magnification

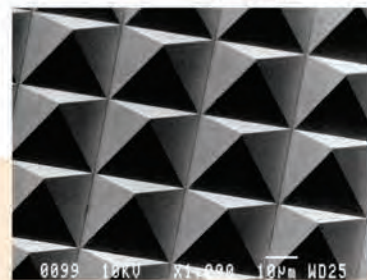
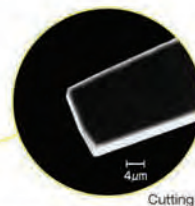

Molds Surface by microforming

cutting tools

Nano-cutting and micro-cutting technologies

Polishing and measuring technologies

Measuring technologies used for diamond selection

ALMT
Products





High-precision cutting of aspheric surfaces, curved and flat surfaces, and V-grooves. Special edge preparations are available

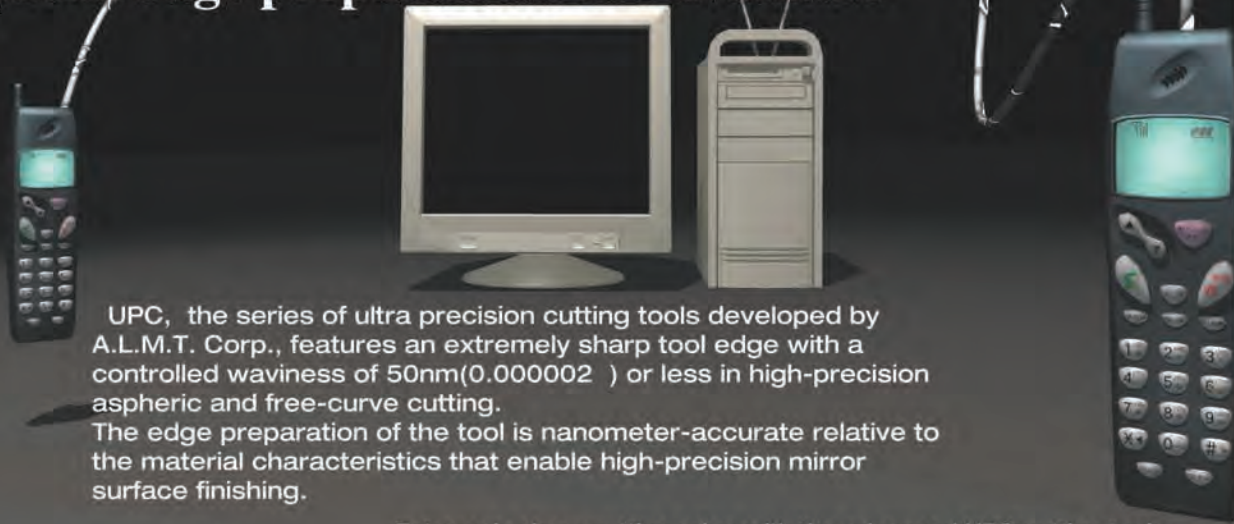

UPC, the series of ultra precision cutting tools developed by A.L.M.T. Corp., features an extremely sharp tool edge with a controlled waviness of 50nm(0.000002) or less in high-precision aspheric and free-curve cutting. The edge preparation of the tool is nanometer-accurate relative to the material characteristics that enable high-precision mirror surface finishing.

Extremely sharp cutting edge with the advanced UPC cutting tools

ALMT Products

1
Feature

UPC-R

The UPC-R shows extraordinary success in ultra-precision spherical and aspherical cutting applications



Application

1. CD·DVD pickup lenses molding
2. Molding for optical lenses for cameras
3. Spherical and aspherical reflecting mirrors for laser and X-ray equipment
4. Spherical and aspherical lenses
5. Other precision parts machied with CNC 2-axis lathe

Features

1. A tool edge contour of 0.05 μ m (50nm / 0.000002") is achieved over a wide working angle of 90°.
2. The cutting edge is precisely finished with minimal waviness. The use of SEM at 2000x magnification for inspection eliminates chipping on the finished tool edge surface.
3. A record of the tool edge contour obtained by our newly developed measuring system (resolution of 5nm) is attached to each tool to guarantee the quality.

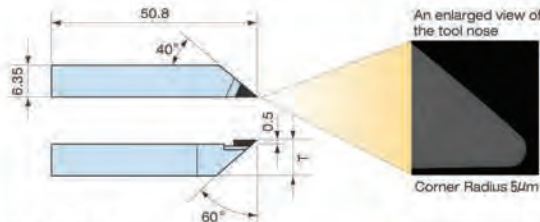

Tool nose shape

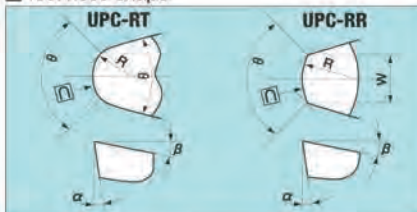

Dimensions & Limit Precision

Type	Contour (n)			Corner Radius R	Tool Edge Angle β	Tool Width W	Clearance Angle α	Face Angle β
	$\theta \leq 90^\circ$	$\theta \leq 120^\circ$	$\theta \leq 150^\circ$					
UPC-RT	Ultra-precision	0.05 μ m	0.15 μ m	0.20 μ m	0.01~3 mm	min15°	0°~20°	-30°~-10°
	Precision	0.5 μ m	1.0 μ m	2.0 μ m				
UPC-RR	Ultra-precision	0.05 μ m	0.15 μ m	0.20 μ m	0.10~200mm	—	0°~20°	-30°~-10°
	Precision	0.5 μ m	1.0 μ m	2.0 μ m				





2
Feature

UPC-F

The UPC-F shows its supremacy in high-efficiency and ultra-precision surface and cylindrical cutting applications.



Application

1. laser reflecting mirrors
2. Polygon mirrors
3. Copier sensitive drums
4. Ultra-fine flat or cylindrical surfaces

Features

1. The time required for break-in operation for the initial usage is eliminated or greatly reduced.
2. The edge preparation of the cutting tool is based on the material and the cutting conditions to provide a uniform and high-quality surface finish.

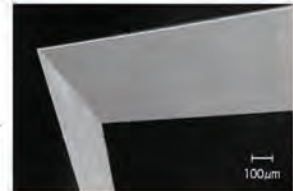

Tool nose shape

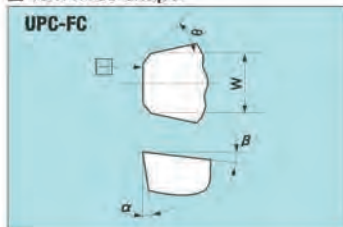

Shape Dimensions

Type	Tool Edge Angle β	Tool Width W	Clearance Angle α	Face Angle β	Horizontal Face Angle γ	Corner Radius R
UPC-FC	45°~80°	1.0~4.0mm	0°~5°	-5°~0°	0°~15°	—

3
Feature

UPC-T

The UPC-T is the optimal tool for fine grooving applications such as Fresnel lens.



Application

1. Molds of LCD display optical waveguide.
2. Fresnel lens molding.
3. Other fine grooving applications.

Features

1. The cutting edge is uniform and extremely sharp, without chipping or undulation.
2. The shape of the cutting edge is guaranteed to sub micron tolerances.
3. Tool life is long to optimize crystal orientation.

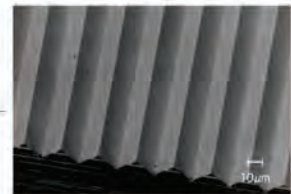

Molds of LCD display optical waveguide

Tool nose shape

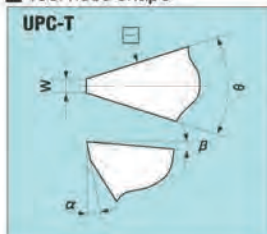

Shape Dimensions

Type	Tool Edge Angle β	Leading Edge Width W	Straightness \square	Clearance Angle α	Face Angle β
UPC-T	Ultraprecision	min0.2µm	0.05µm	0°~15°	-5°~10°
	Precision	min2µm	0.1µm		



The Transition

Highly efficient



Our PCD Reamers Make Efficient and High-speed Cutting Possible

Advantages Gained by Upgrading from a Carbide Reamer to a PCD Reamer

High Efficiency / Reduction of Tool Cost

- Improvement in tool life
- Improvement in machining accuracy
- Reduction of machining time
- Reduction of frequency of tool replacement

Features

1. Multistage machining can be done on one pass by using an integrated profiled step tool.
2. Long tool life with sharp cutting edge made by adopted grinding technology providing excellent sharpness and wear resistance compared to cemented carbide tools.
3. Excellent machining surfaces can be obtained by rapid feed even with cutting speeds at 500 m/min.
4. Stable cutting and sufficient performance when using emulsion type water-soluble coolant.
5. New mechanism that prevents various common machining troubles

Examples of troubles

- **Vibration, chattering** → Assurance of dynamic balance
- **Built-up edge** → Surface finishing to prevent built-up edge
- **Clogging of tools with cutting chips** → Chip breaker process



Transition from Carbide to PCD Reamer

Efficient, accurate and high grade multi-step holes can be machined in a single process

High machining accuracy combined with mass-production at low cost is required for the processing of aluminum alloys for auto parts these days. Our PCD (Poly Crystalline Diamond) cutting tools achieve long tool life and high machining accuracy by constructing sharp cutting edges which use grinding technology applied to PCD with the resulting special feature that tool hardness is effectively more than 10 times that of carbide made tools. Longer life of PCD cutting tools improves productivity, reduces the frequency of tool replacement and machining cost. In addition, machining accuracy and discharge of cutting chips have been improved by cutting edge grinding technology and strengthening the breaker function. We, A.L.M.T. Corp., will respond to all requests from diversified automobile parts manufacturers as a pioneer manufacturer of diamond tools



《Reduction of Tooling Cost and Improvements in Productivity》

● Tool life

Work material	Carbide	PCD
ADC12 (Contains 12% Si)	1	10~20
A390 (Contains 18% Si)	1	20~

● Cutting machining time

(Test) Item	Carbide	PCD
Number of rotations S (min ⁻¹)	2000	6000
Cutting speed V (m/min)	125	380
Feeding speed F (mm/min)	600	1800
Machining time	3	1
Tool size	∅20x4NT (Machining depth 20mm)	

● Number of tool replacement

(Test) Item	Carbide	PCD
Number of tool replacement	10 times	once

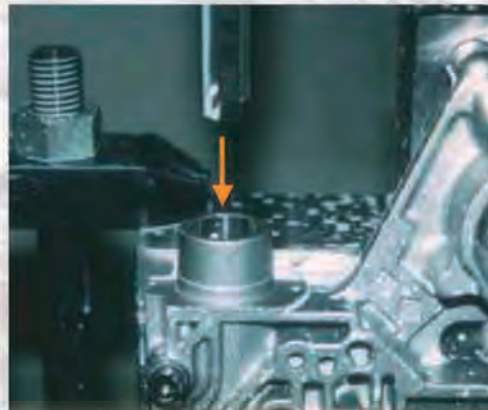

Purposes Nonferrous metal (Aluminum alloy)

Machined components

- Cylinder head
- Cylinder block
- Transmission/steering components
- Compressor components

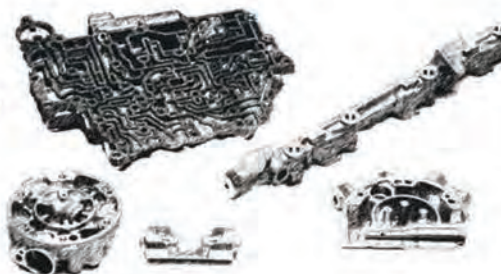



The position of diamonds

In the field of cutting tools, diamonds with excellent material features are in the limelight as the material that is expected to be applied for fine shape machining as well as various requests and issues in high grade and high efficient machining.

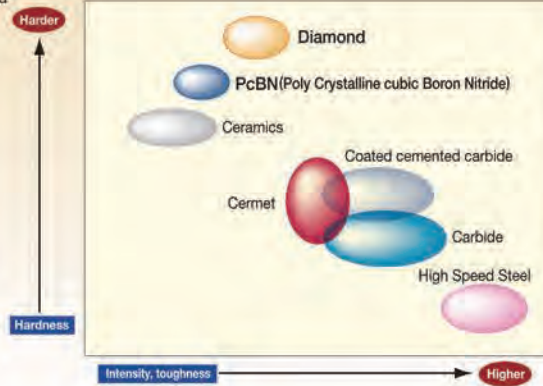
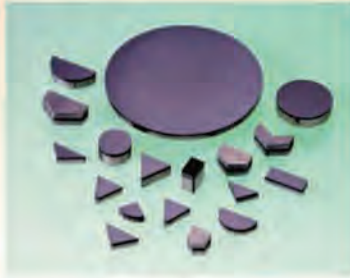

Material features of PCD (Poly Crystalline Diamond)

The features of PCD (Poly Crystalline Diamond) in poly crystalline cutting tool materials are as follows:
 1. High hardness is high 2. High thermal conductivity is high 3. Coefficient of thermal expansion is small.
 It has excellent thermal conductivity and hardness, that is required for cutting tools, compared to other tool materials.

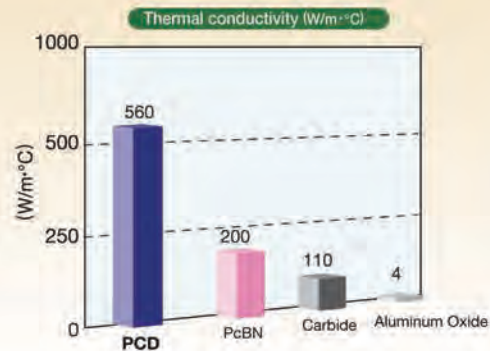
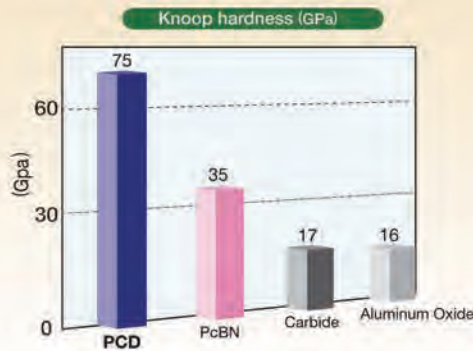

Comparison of cutting performance between PCD (Poly Crystalline Diamond) and carbide tools

Longer life than carbide by a ratio of 10 to 20 times

A390-T6 and ADC-12 that are widely used as a main material for automotive components had many problems such as grade of processing surface and running cost for machining with carbide cutting tools. PCD has cleared various problems, especially machining ADC-12 which is difficult to cut, due to its longer tool life and stable machining accuracy compared to carbide.

A390-T6 Cutting distance and flank face wear width

Cutting distance(km)	0.6	1.0	1.5	2.0	3.0	4.0	5.0
PCD flank face wear width(μm)	28	35	50	55	60	70	80
Carbide flank face wear width(μm)	600	1000	1500	Inmeasurable			

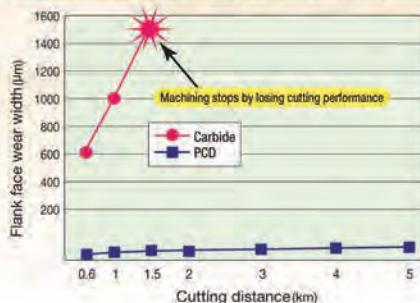

ADC12 Cutting distance and flank face wear width

Cutting distance(km)	0.6	1.0	2.0	6.0	10.0	20.0	30.0
PCD flank face wear width(μm)	10	20	22	30	40	70	100
Carbide flank face wear width(μm)	30	35	40	55	90	200	-

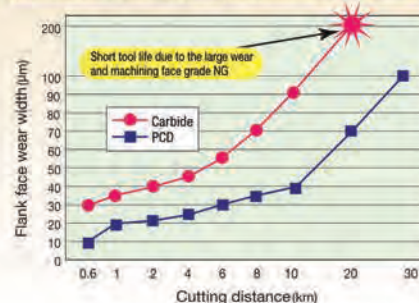

Data.1

Amazing accuracy

Generated from segmented cutting chips



Breaker function has been enhanced as a method to resolve deteriorating productivity due to the cutting chip troubles. We can also suggest [other] precautions and procedures against various cutting chip troubles.

Solving problems

A. Length of cutting chips

- ① **Edge honing specifications**
Bend the flow of cutting chips moderately to shorten the length of cutting chips.
- ② **Breaker specifications**
Curl the cutting chips by the wall surface of the breaker to forcibly shorten the length of cutting chips.

Edge honing specification cutting edge

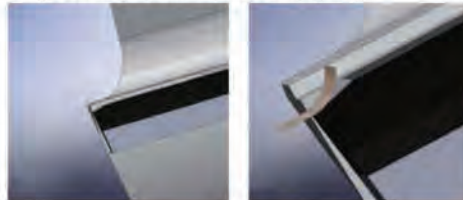

B. Width of cutting chips

- ③ **Nick Specifications**
Shorten the width of cutting chips by a recess prepared on the cutting edge.



Without breaker



With breaker

Divided cutting chips

Cutting chips curl thickly and they divide



● Cutting resistance and contour accuracy have been improved by grinding technology

Conventional machining

Special grinding machining



Old



New

High machining accuracy without white turbidity is achieved by segmentalizing cutting chips





Data.2

Ability of Design and Quality *[Achieved both high efficiency cutting and high machining accuracy]*



The concentricity and roundness of cutting edges have improved spectacularly by high shank rigidity (carbide) and grinding technology on the cutting edge.

The machining efficiency per cutting edge has improved by cutting down the machining time.

Deformation volume by CAE analysis

Shank material: Steel

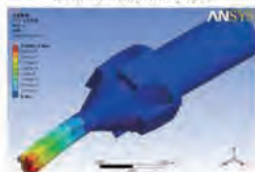

Shank material: Cemented carbide

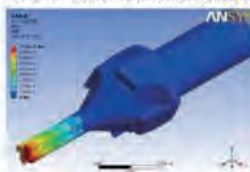

Machining conditions	
Name of work piece	Cylinder head, valve seat and guide hole
Work material	Aluminum alloy casting AC4B
Machines	Horizontal machining center
Tool size	Ø11-Ø3.6-L150
Number of rotations (min ⁻¹)	3500
Cutting speed (m/min)	395
Feeding rate (mm/rev)	0.3
Depth of cut (mm/diameter)	0.5
Coolant	Emulsion type water-soluble coolant

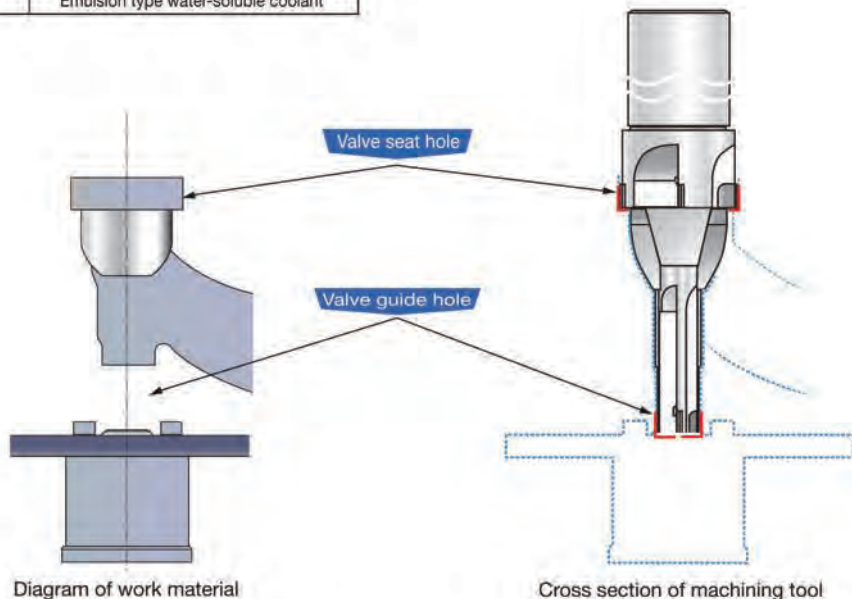

Differences of performance between shank materials

Machining results	one tooth	four teeth (steel)	four teeth (carbide)
Machining time(s)	52	26	13
Circularity (mm)	0.01	0.05	0.03
Coaxiality (mm)	0.01	0.07	0.05

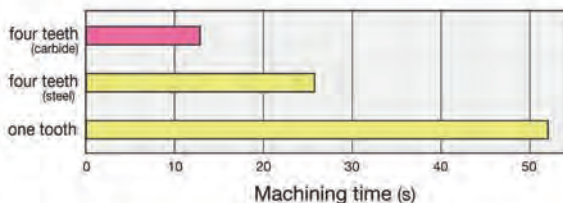



Machining application

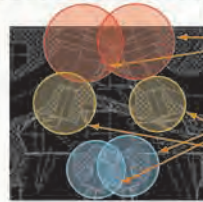

Stage 1 Valve seat and guide hole

Stage 2 HLA(Hydraulic Lash) Adjuster hole finishing

Stage 3 Intake & exhaust valve guide hole finishing



Stage 1 Valve seat and guide hole finishing

The issues such as concentricity and cylindricity are solved by high shank rigidity and high cutting edge accuracy.

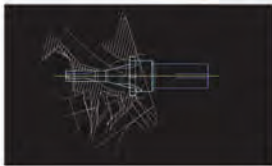

Valve seat and guide hole finishing specifications

Machine : Horizontal machining center		
Machining conditions	Number of rotations (min ⁻¹)	6,000
	Feeding rate (mm/rev)	0.48
	Feeding speed (mm/min)	2,880
	Depth of cut (mm/diameter)	0.6
	Coolant	Emulsion type water-soluble coolant



Stage 2 Hydraulic lash adjuster hole finishing

The issues such as removal of cutting chips and cylindricity are solved by the design that responded to thin-walled & blind hole machining portions.



HLA (Hydraulic Lash Adjuster) hole finishing specifications

Machine : Horizontal machining center		
Machining conditions	Number of rotations (min ⁻¹)	5,000
	Feeding rate (mm/rev)	0.34
	Feeding speed (mm/min)	1,700
	Depth of cut (mm/diameter)	0.5
	Coolant	Emulsion type water-soluble coolant



Stage 3 Intake & exhaust valve guide hole finishing

Concentricity and cylindricity of cutting edge are controlled highly accurately and the self-guide effect is enhanced in order to respond to long overhang and bending moment by small diameter. Moreover, the discharge amount of cutting chips has improved by the guide hole shape and coolant design. As a result, it can machine 10 times more the number of holes compared to cemented carbide to improve productivity.



Intake & exhaust valve guide hole finishing specifications

Machine : Horizontal machining center		
Machining conditions	Number of rotations (min ⁻¹)	3,250
	Feeding rate (mm/rev)	0.1
	Feeding speed (mm/min)	325
	Depth of cut (mm/diameter)	0.1
	Coolant	Emulsion type water-soluble coolant

Machining results

Cutting tool	Tool life(number of machined holes)	Ratio of prices	Ratio of costs	Coaxiality	Inner diameter change volume
Carbide	1,200	1	1	—	—
Our PCD tool	12,000	3	0.8	10μm	3μm/10,000hole

PCD reamer



Application of PCD reamer machining

Reamer machining of automobile hydraulic regulator valves

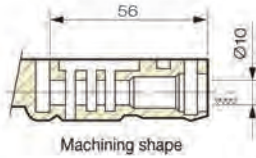

Item	Carbide reamer	PCD reamer
Cutting speed (m/min)	120	120
Feeding speed (mm/rev)	0.2	0.2
Depth of cut (mm/diameter)	0.4	0.4
Coolant	oil-based	water-soluble based
Machining surface roughness (µmRz)	8	3
Circularity	10	5
Running cost	1	0.5

Shape

Cutting edge diameter ϕD	Maximum number of edges	Other specifications
"3 \Leftarrow ϕ < 4"	1tooth	Blade diameter tolerance Standard specifications $\phi D \pm 0.0025\text{mm}$ High-accurate specifications $\phi D \pm 0.0015\text{mm}$ (5 or bigger and 25 or below) Along the length : Maximum length 450mm (Standard L/D= from 3 to 5)
"4 \Leftarrow ϕ < 6"	3teeth	
"6 \Leftarrow ϕ < 8"	4teeth	
"8 \Leftarrow ϕ	6teeth	

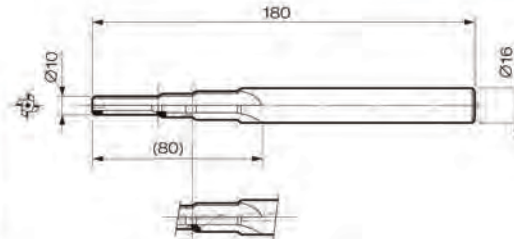

Our products

PCD reamer (Single-step reamer)



Body materials (1) Solid carbide (2) Combination of carbide and steel (3) Hardened steel
Applications : HDD, CD-ROM, rocker-arms, etc.



PCD reamer (with chamfering tip)



Body materials (1) Solid carbide (2) Combination of carbide and steel (3) Hardened steel
Applications : Compressor body, ABS actuator, power steering body, etc.

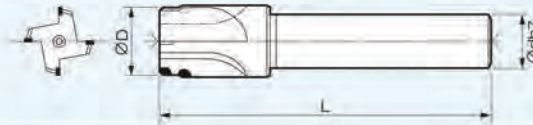

PCD reamer (PCD Profiled step reamer)



Body materials (1) Solid carbide (2) Combination of carbide and steel (3) Hardened steel
Applications : Oil pumps, steering, AT hydraulic control body, etc.



PCD gun reamer (Multiple-step reamer)



Body materials (1) Combination of carbide and steel
Applications : AT hydraulic control body, etc.

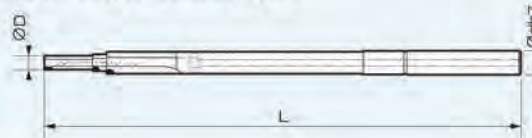

PCD reamer (with breakers)



Body materials (1) Combination of carbide and steel
Applications : ABS body, Oil pumps, AT hydraulic control body, etc.

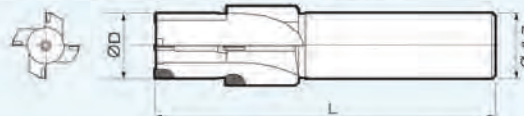

ADAPTERS & HOLDERS

Pages 539-563



Adapters & Holders

ADAPTERS & HOLDERS	PAGES
Holder and Collet Highlights.....	540
Adapters & Holders: Milling Chucks.....	541
Sumi Power Milling Chucks	542
ER Collet Chucks.....	543
Straight Shank Synchro Chucks	544
ER Collets -Inch & Metric.....	545
GB Collets.....	546
Shrink Fit System	547-551
Endmill Holders	552-553
Shellmill Holders	554-555
• Hardware	
ER Collet Nut	556
Sealing Discs	557-558
Drive Keys and Locking Screws	559-560
Wrenches	561
Accessories.....	562-563

AVAILABILITY:
All holders, collets and accessories have a minimum shipment time of 3 working days after receipt of order at Sumitomo.



CNC Holders

CNC Holder line provides options for all industry-standard sizes and configurations for collet chucks, end mill holders, shell mill holders, hi-power milling chucks, and face mill holders.

Each product represents the latest technology, and reflects our commitment to quality and innovation. We also support our products with unmatched application expertise and customer service.



Induction Shrink-Fit System

The finest shrink fit holders available. Precise manufacturing and exclusive "counter bore" technology optimize the advantages of using shrink fit tooling. These holders offer the best part finish quality, longer tool life, and higher feed rates and speeds. All of this is accomplished due to micrometer accuracy in runout, high cutting tool rigidity and extremely high clamping forces.



Tightening Fixtures and Retention Knobs

Our tightening fixtures are the best and simplest in the world. You gain immediate access to both the working and taper ends. Less handling just means fewer chances of costly holders being dropped and damaged.

Our retention knobs are manufactured from the finest and most consistent steels required. Accurately machined surfaces and quality threads mean constant productivity and less down-time.

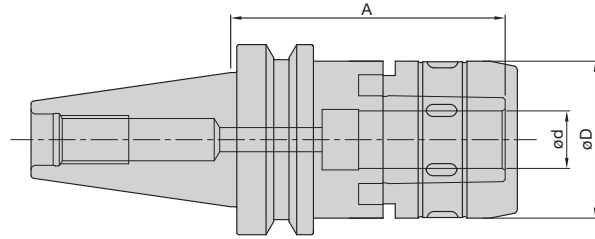
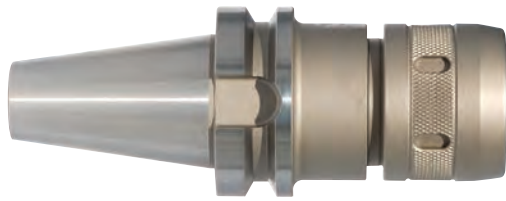

Milling Chucks					
Catalog Number	Dimensions				
	d (mm)	d (inch)	D (mm)	A (mm)	A (inch)
CAT40					
Balanced to G6.3 @ 8,000 RPM					
SHPMC0.750-3.54-CAT40	19.05	0.75	52	89.9	3.54
SHPMC1.000-3.54-CAT40	25.4	1.00	58	89.9	3.54
SHPMC1.250-4.25-CAT40	31.75	1.25	66	108.0	4.25
SHPMC25-90-CAT40	25	-	58	90	-
SHPMC32-105-CAT40	32	-	66	105	-
CAT50					
Balanced to G6.3 @ 8,000 RPM					
SHPMC0.750-3.54-CAT50	19.05	0.75	52	89.9	3.54
SHPMC0.750-6.50-CAT50	19.05	0.75	52	165.1	6.50
SHPMC1.000-3.54-CAT50	25.4	1.00	58	89.9	3.54
SHPMC1.000-5.31-CAT50	25.4	1.00	58	134.9	5.31
SHPMC1.250-4.13-CAT50	31.75	1.25	66	104.9	4.13
SHPMC1.250-5.31-CAT50	31.75	1.25	66	134.9	5.31
SHPMC2.000-4.72-CAT50	50.8	2.00	103	119.9	4.72
SHPMC2.000-5.90-CAT50	50.8	2.00	103	149.9	5.90
SHPMC32-105-CAT50	32	-	58	105	-
SHPMC50-135-CAT50	50	-	103	135	-
BT30					
Balanced to G6.3 @ 8,000 RPM					
SHPMC0.750-3.54-BT30	19.05	0.75	52	89.9	3.54
SHPMC20-90-BT30	20	-	52	90	-
SHPMC25-90-BT30	25	-	58	90	-
SHPMC32-105-BT30	32	-	66	105	-

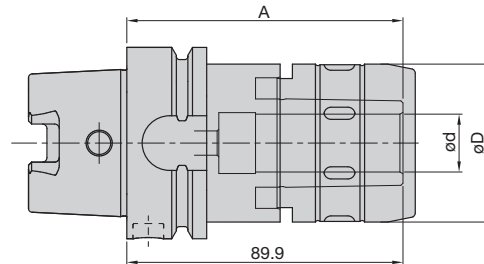

HSK Milling Chucks					
Catalog Number	Dimensions				
	d (mm)	d (inch)	D (mm)	A (mm)	A (inch)
HSK-A63					
Balanced to G6.3 @ 8,000 RPM					
SHPMC0.750-3.54-HSKA63	19.05	0.75	52	89.9	3.54
SHPMC1.000-4.13-HSKA63	25.4	1.00	58	104.9	4.13
SHPMC1.250-4.72-HSKA63	31.75	1.25	66	119.9	4.72
SHPMC20-90-HSKA63	20	-	52	90	-
SHPMC25-105-HSKA63	25	-	58	105	-
SHPMC32-135-HSKA63	32	-	66	135	-
HSK-A100					
Balanced to G6.3 @ 15,000 RPM					
SHPMC0.750-3.94-HSKA100	-	0.750	52	-	3.94
SHPMC1.000-4.53-HSKA100	-	1.000	58	-	4.53
SHPMC1.250-5.31-HSKA100	-	1.250	66	-	5.31
SHPMC20-100-HSKA100	20	-	52	100mm	-
SHPMC25-115-HSKA100	25	-	58	115mm	-
SHPMC32-135-HSKA100	32	-	66	135mm	-

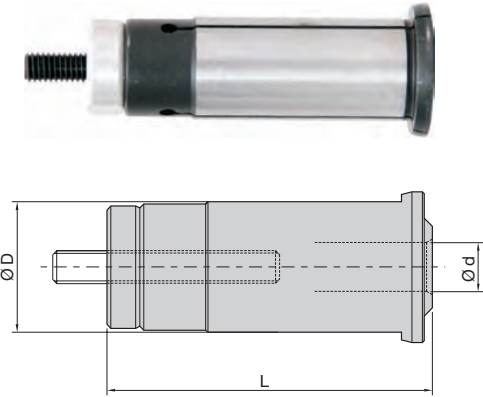

Adjustable Straight Collets for Milling Chucks (Metric)

	Catalog Number	Dimensions (mm)		
		D	d	L
	SSC20-6	20	6	63
	SSC20-8	20	8	63
	SSC20-10	20	10	63
	SSC20-12	20	12	63
	SSC20-16	20	16	63
	SSC25-6	25	6	73
	SSC25-8	25	8	73
	SSC25-10	25	10	73
	SSC25-12	25	12	73
	SSC25-16	25	16	73
	SSC25-18	25	18	73
	SSC25-20	25	20	73
	SSC32-6	32	6	79
	SSC32-8	32	8	79
	SSC32-10	32	10	79
	SSC32-12	32	12	79
	SSC32-16	32	16	79
	SSC32-18	32	18	79
	SSC32-20	32	20	79
	SSC32-25	32	25	79

Adjustable Straight Collets for Milling Chucks (Inch)

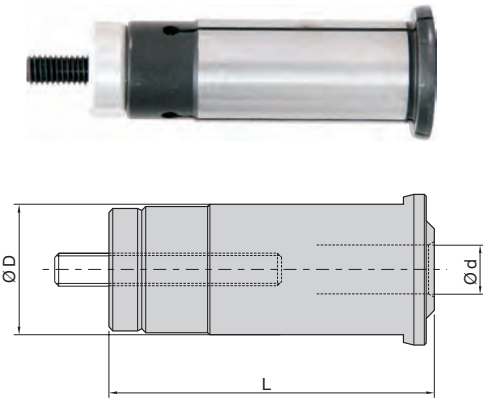
	Catalog Number	Dimensions (inch)		
		D	d	L
	SSC 0.750-0.250	0.750	0.250	2.48
	SSC 0.750-0.312	0.750	0.312	2.48
	SSC 0.750-0.375	0.750	0.375	2.48
	SSC 0.750-0.437	0.750	0.437	2.48
	SSC 0.750-0.500	0.750	0.500	2.48
	SSC 0.750-0.562	0.750	0.562	2.48
	SSC 0.750-0.625	0.750	0.625	2.48
	SSC 1.000-0.250	1.000	0.250	2.87
	SSC 1.000-0.312	1.000	0.312	2.87
	SSC 1.000-0.375	1.000	0.375	2.87
	SSC 1.000-0.437	1.000	0.437	2.87
	SSC 1.000-0.500	1.000	0.500	2.87
	SSC 1.000-0.562	1.000	0.562	2.87
	SSC 1.000-0.625	1.000	0.625	2.87
	SSC 1.000-0.750	1.000	0.750	2.87
	SSC 1.250-0.250	1.250	0.250	3.11
	SSC 1.250-0.312	1.250	0.312	3.11
	SSC 1.250-0.375	1.250	0.375	3.11
	SSC 1.250-0.437	1.250	0.437	3.11
	SSC 1.250-0.500	1.250	0.500	3.11
	SSC 1.250-0.562	1.250	0.562	3.11
	SSC 1.250-0.625	1.250	0.625	3.11
	SSC 1.250-0.750	1.250	0.750	3.11
	SSC 1.250-0.875	1.250	0.875	3.11
	SSC 1.250-1.000	1.250	1.000	3.11

Adjustable Straight Collets for Milling Chucks (Metric to Inch)

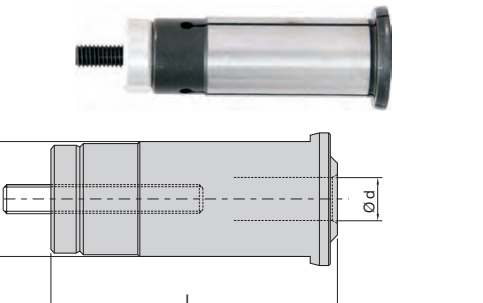
	Catalog Number	Dimensions		
		D	d	L
	SSC32-0.375	32	0.375	3.11
	SSC32-0.500	32	0.500	3.11
	SSC32-0.625	32	0.625	3.11
	SSC32-0.750	32	0.750	3.11
	SSC32-1.000	32	1.000	3.11



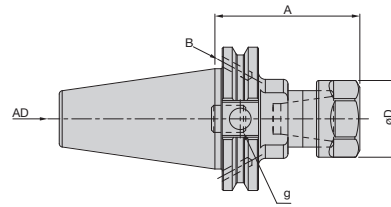

ER Collet Chucks - CAT40 Balanced to G6.3 @ 20,000 RPM

Catalog Number	Dimensions					
	Collet Type	Range (mm)	D (mm)	A (mm)	A (inch)	g
CAT40						
SCCH-ER16-2.50-CAT40	ER16	1-10	28	63.5	2.50	M10
SCCH-ER16-5.00-CAT40	ER16	1-10	28	127.0	5.00	M10
SCCH-ER20-2.50-CAT40	ER20	1-13	34	63.5	2.50	M12
SCCH-ER20-6.00-CAT40	ER20	1-13	34	152.4	6.00	M12
SCCH-ER25-2.50-CAT40	ER25	2-16	42	63.5	2.50	M16
SCCH-ER25-6.00-CAT40	ER25	2-16	42	152.4	6.00	M16
SCCH-ER32-2.75-CAT40	ER32	2-20	50	69.9	2.75	M22x1.5
SCCH-ER32-6.00-CAT40	ER32	2-20	50	152.4	6.00	M22x1.5
SCCH-ER40-3.00-CAT40	ER40	3-26	63	76.2	3.00	M22x1.5
SCCH-ER40-6.00-CAT40	ER40	3-26	63	152.4	6.00	M22x1.5

ER Collet Chucks - CAT50 Balanced to G6.3 @ 20,000 RPM

Catalog Number	Dimensions					
	Collet Type	Range (mm)	D (mm)	A (mm)	A (inch)	g
CAT50						
SCCH-ER16-2.50-CAT50	ER16	1-10	28	63.5	2.50	M10
SCCH-ER16-4.00-CAT50	ER16	1-10	28	101.6	4.00	M10
SCCH-ER16-6.00-CAT50	ER16	1-10	28	152.4	6.00	M10
SCCH-ER20-2.50-CAT50	ER20	1-13	34	63.5	2.50	M12
SCCH-ER20-4.00-CAT50	ER20	1-13	34	101.6	4.00	M12
SCCH-ER20-6.00-CAT50	ER20	1-13	34	152.4	6.00	M12
SCCH-ER25-2.50-CAT50	ER25	2-16	42	63.5	2.50	M16
SCCH-ER25-4.00-CAT50	ER25	2-16	42	101.6	4.00	M16
SCCH-ER25-6.00-CAT50	ER25	2-16	42	152.4	6.00	M16
SCCH-ER32-2.75-CAT50	ER32	2-20	50	69.9	2.75	M22x1.5
SCCH-ER32-4.00-CAT50	ER32	2-20	50	101.6	4.00	M22x1.5
SCCH-ER32-6.00-CAT50	ER32	2-20	50	152.4	6.00	M22x1.5
SCCH-ER40-3.00-CAT50	ER40	3-26	63	76.2	3.00	M22x1.5
SCCH-ER40-4.00-CAT50	ER40	3-26	63	101.6	4.00	M22x1.5
SCCH-ER40-6.00-CAT50	ER40	3-26	63	152.4	6.00	M22x1.5

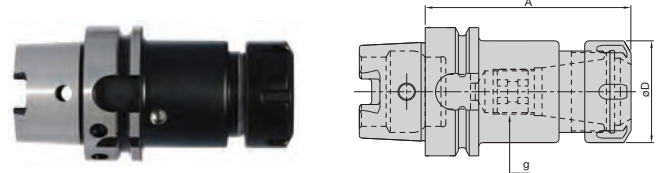
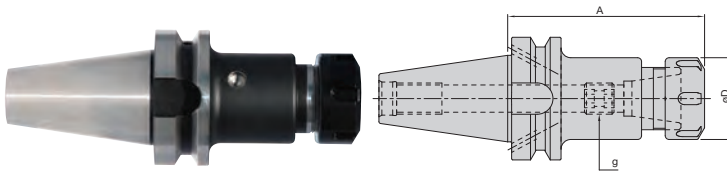

ER Collet Chucks Balanced to G6.3 @ 20,000 RPM

Catalog Number	Dimensions					
	Collet Type	Range (mm)	D (mm)	A (mm)	A (inch)	g
BT30						
SCCH-ER16-100-BT30	ER16	1-10	28	100	3.94	M10
SCCH-ER16-150-BT30	ER16	1-10	28	150	5.90	M10
SCCH-ER16-70-BT30	ER16	1-10	28	70	2.76	M10
SCCH-ER20-100-BT30	ER20	1-13	34	100	3.94	M12
SCCH-ER20-70-BT30	ER20	1-13	34	70	2.76	M12
SCCH-ER25-100-BT30	ER25	2-16	42	100	3.94	M12
SCCH-ER25-70-BT30	ER25	2-16	42	70	2.76	M12
SCCH-ER32-100-BT30	ER32	2-20	50	100	3.94	M22x1.5
SCCH-ER32-70-BT30	ER32	2-20	50	70	2.76	M12
SCCH-ER40-100-BT30	ER40	3-26	63	100	3.89	M22x1.5
BT40						
SCCH-ER16-100-BT40	ER16	1-10	28	100	3.94	M10
SCCH-ER16-160-BT40	ER16	1-10	28	160	6.30	M10
SCCH-ER16-70-BT40	ER16	1-10	28	70	2.76	M10
SCCH-ER20-100-BT40	ER20	1-13	34	100	3.94	M12
SCCH-ER20-160-BT40	ER20	1-13	34	160	6.30	M12
SCCH-ER20-70-BT40	ER20	1-13	34	70	2.76	M12
SCCH-ER25-100-BT40	ER25	2-16	42	100	3.94	M16
SCCH-ER25-160-BT40	ER25	2-16	42	160	6.30	M16
SCCH-ER25-70-BT40	ER25	2-16	42	70	2.76	M16
SCCH-ER32-100-BT40	ER32	2-20	50	100	3.94	M22x1.5
SCCH-ER32-160-BT40	ER32	2-20	50	160	6.30	M22x1.5
SCCH-ER32-70-BT40	ER32	2-20	50	70	2.76	M22x1.5
SCCH-ER40-100-BT40	ER40	3-26	63	100	3.94	M22x1.5
SCCH-ER40-160-BT40	ER40	3-26	63	160	6.30	M22x1.5
SCCH-ER40-80-BT40	ER40	3-26	63	80	3.15	M22x1.5

HSK ER Collet Chuck Holders Balanced to G6.3 @ 20,000 RPM

Catalog Number	Dimensions					
	Collet Type	Range (mm)	D (mm)	A (mm)	A (inch)	g
HSK-A63						
SCCH-ER16M-100-HSKA63	ER16	1-10	28	100	3.94	M10
SCCH-ER16M-160-HSKA63	ER16	1-10	28	160	6.3	M10
SCCH-ER20-100-HSKA63	ER20	1-13	34	100	3.94	M12
SCCH-ER20M-160-HSKA63	ER20	1-13	34	160	6.3	M12
SCCH-ER25-100-HSKA63	ER25	2-16	42	100	3.94	M16
SCCH-ER25M-160-HSKA63	ER25	2-16	42	160	6.3	M16
SCCH-ER32-100-HSKA63	ER32	2-20	50	100	3.94	M22x1.5
SCCH-ER32-160-HSKA63	ER32	2-20	50	160	6.3	M22x1.5
SCCH-ER40-120-HSKA63	ER40	3-26	63	120	4.72	M22x1.5
SCCH-ER40-160-HSKA63	ER40	3-26	63	160	6.3	M22x1.5
HSK-A100						
SCCH-ER16M-100-HSKA100	ER16M	1-10	22	100	3.94	M10
SCCH-ER20-100-HSKA100	ER20	1-13	34	100	3.94	M12
SCCH-ER25-100-HSKA100	ER25	2-16	42	100	3.94	M16
SCCH-ER32-100-HSKA100	ER32	2-20	50	100	3.94	M22x1.5
SCCH-ER40-120-HSKA100	ER40	3-26	63	120	4.72	M22x1.5
SCCH-ER16M-160-HSKA100	ER16M	1-10	22	160	6.3	M10
SCCH-ER20-160-HSKA100	ER20	1-13	34	160	6.3	M12
SCCH-ER25-160-HSKA100	ER25	2-16	42	160	6.3	M16
SCCH-ER32-160-HSKA100	ER32	2-20	50	160	6.3	M22x1.5
SCCH-ER40-160-HSKA100	ER40	3-26	63	160	6.3	M22x1.5



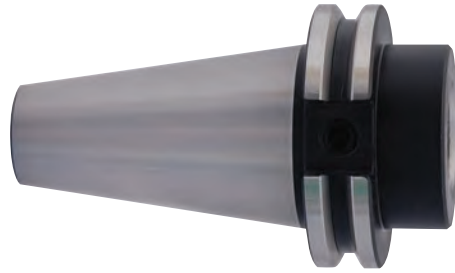
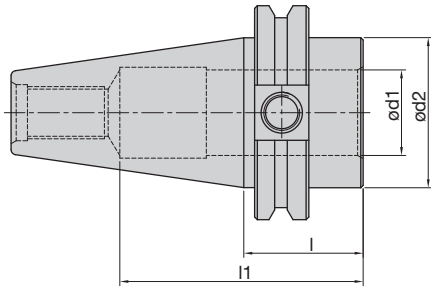

Straight Shank Synchro Chucks					
Catalog Number	Spindle Type	Dimensions			
		d1 (in)	d2(mm)	l1 (mm)	l (in)
SSSC-CT40-1.000	CAT40	1	45	68.5	1.375
SSSC-CT50-1.000	CAT50	1	70	84.5	1.375
SSSC-CT50-1.500	CAT50	1.5	70	84.5	1.375
SSSC-BT40-1.000	BT40	1	45	68.5	1.062
SSSC-BT50-1.000	BT50	1	70	84.5	1.875
SSSC-BT50-1.500	BT50	1.5	70	84.5	1.875

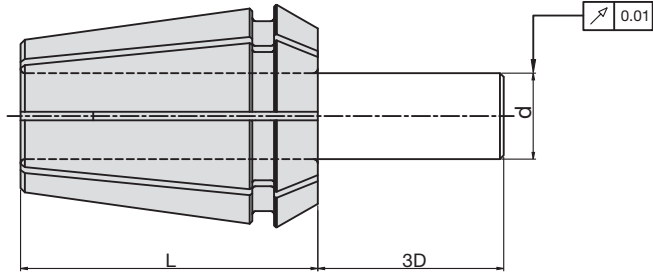

Spring Collets ER16 (Inch)			
Catalog Number	Dimensions (inch)		
	D	L	d
ER16-1/16	0.669	1.063	0.043-0.062
ER16-3/32	0.669	1.063	0.054-0.093
ER16-1/8	0.669	1.063	0.086-0.125
ER16-5/32	0.669	1.063	0.117-0.156
ER16-3/16	0.669	1.063	0.148-0.187
ER16-7/32	0.669	1.063	0.179-0.218
ER16-1/4	0.669	1.063	0.211-0.250
ER16-9/32	0.669	1.063	0.242-0.281
ER16-5/16	0.669	1.063	0.273-0.312
ER16-11/32	0.669	1.063	0.304-0.343
ER16-3/8	0.669	1.063	0.336-0.375
ER16-13/32	0.669	1.063	0.367-0.406
ER16 12pc. Collet Set	-	-	-
ER20(Inch)			
ER20-1/8	0.827	1.22	0.086-0.125
ER20-3/16	0.827	1.22	0.148-0.187
ER20-1/4	0.827	1.22	0.211-0.250
ER20-5/16	0.827	1.22	0.273-0.312
ER20-3/8	0.827	1.22	0.336-0.375
ER20-7/16	0.827	1.22	0.398-0.437
ER20-1/2	0.827	1.22	0.461-0.500
ER20 7pc. Collet Set	-	-	-
ER25 (Inch)			
ER25-1/8	1.024	1.378	0.086-0.125
ER25-3/16	1.024	1.378	0.148-0.187
ER25-1/4	1.024	1.378	0.211-0.250
ER25-5/16	1.024	1.378	0.273-0.312
ER25-3/8	1.024	1.378	0.336-0.375
ER25-7/16	1.024	1.378	0.398-0.437
ER25-1/2	1.024	1.378	0.461-0.500
ER25-9/16	1.024	1.378	0.523-0.562
ER25-5/8	1.024	1.378	0.586-0.625
ER25 9pc. Collet Set	-	-	-

Spring Collets ER 32(Inch)			
Catalog Number	Dimensions (inch)		
	D	L	d
ER32-1/8	1.299	1.575	0.086-0.125
ER32-3/16	1.299	1.575	0.148-0.187
ER32-1/4	1.299	1.575	0.211-0.250
ER32-5/16	1.299	1.575	0.273-0.312
ER32-3/8	1.299	1.575	0.336-0.375
ER32-7/16	1.299	1.575	0.398-0.437
ER32-1/2	1.299	1.575	0.461-0.500
ER32-9/16	1.299	1.575	0.523-0.562
ER32-5/8	1.299	1.575	0.586-0.625
ER32-11/16	1.299	1.575	0.648-0.687
ER32-3/4	1.299	1.575	0.711-0.750
ER32 12pc. Collet Set	-	-	-
ER40 (Inch)			
ER40-1/8	1.614	1.811	0.086-0.125
ER40-3/16	1.614	1.811	0.148-0.187
ER40-1/4	1.614	1.811	0.211-0.250
ER40-5/16	1.614	1.811	0.273-0.312
ER40-3/8	1.614	1.811	0.336-0.375
ER40-7/16	1.614	1.811	0.398-0.437
ER40-1/2	1.614	1.811	0.461-0.500
ER40-9/16	1.614	1.811	0.523-0.562
ER40-5/8	1.614	1.811	0.586-0.625
ER40-11/16	1.614	1.811	0.648-0.687
ER40-3/4	1.614	1.811	0.711-0.750
ER40-7/8	1.614	1.811	0.836-0.875
ER40-1.0	1.614	1.811	0.961-1.000
ER40 14pc. Collet Set	-	-	-

Spring Collets ER16 (Metric)			
Catalog Number	Dimensions (mm)		
	D	L	d
ER16-1.0	17	27	1.0-0.5
ER16-1.5	17	27	1.5-1.0
ER16-2.0	17	27	2.0-1.5
ER16-2.5	17	27	2.5-2.0
ER16-3.0	17	27	3.0-2.5
ER16-3.5	17	27	3.5-3.0
ER16-4.0	17	27	4.0-3.5
ER16-4.5	17	27	4.5-4.0
ER16-5.0	17	27	5.0-4.5
ER16-5.5	17	27	5.5-5.0
ER16-6.0	17	27	6.0-5.5
ER16-6.5	17	27	6.5-6.0
ER16-7.0	17	27	7.0-6.5
ER16-7.5	17	27	7.5-7.0
ER16-8.0	17	27	8.0-7.5
ER16-8.5	17	27	8.5-8.0
ER16-9.0	17	27	9.0-8.5
ER16-9.5	17	27	9.5-9.0
ER16-10.0	17	27	10.0-9.5
ER16 10pc. Collet Set	-	-	-
ER20 (Metric)			
ER20-1.0	21	31	1.0-0.5
ER20-2.0	21	31	2.0-1.5
ER20-3.0	21	31	3.0-2.5
ER20-4.0	21	31	4.0-3.5
ER20-5.0	21	31	5.0-4.5
ER20-6.0	21	31	6.0-5.5
ER20-7.0	21	31	7.0-6.5
ER20-8.0	21	31	8.0-7.5
ER20-9.0	21	31	9.0-8.5
ER20-10.0	21	31	10.0-9.5
ER20-11.0	21	31	11.0-10.5
ER20-12.0	21	31	12.0-11.5
ER20-13.0	21	31	13.0-12.5
ER20 12pc. Collet Set	-	-	-
ER25 (Metric)			
ER25-2.0	26	35	2.0-1.5
ER25-3.0	26	35	3.0-2.5
ER25-4.0	26	35	4.0-3.5
ER25-5.0	26	35	5.0-4.5
ER25-6.0	26	35	6.0-5.5
ER25-7.0	26	35	7.0-6.5
ER25-8.0	26	35	8.0-7.5
ER25-9.0	26	35	9.0-8.5
ER25-10.0	26	35	10.0-9.5
ER25-11.0	26	35	11.0-10.5
ER25-12.0	26	35	12.0-11.5
ER25-13.0	26	35	13.0-12.5
ER25-14.0	26	35	14.0-13.5
ER25-15.0	26	35	15.0-14.5
ER25-16.0	26	35	16.0-15.5
ER25 15pc. Collet Set	-	-	-

Spring Collets ER32 (Metric)			
Catalog Number	Dimensions (mm)		
	D	L	d
ER32-2.0	33	40	2.0-1.5
ER32-3.0	33	40	3.0-2.5
ER32-4.0	33	40	4.0-3.5
ER32-5.0	33	40	5.0-4.5
ER32-6.0	33	40	6.0-5.5
ER32-7.0	33	40	7.0-6.5
ER32-8.0	33	40	8.0-7.5
ER32-9.0	33	40	9.0-8.5
ER32-10.0	33	40	10.0-9.5
ER32-11.0	33	40	11.0-10.5
ER32-12.0	33	40	12.0-11.5
ER32-13.0	33	40	13.0-12.5
ER32-14.0	33	40	14.0-13.5
ER32-15.0	33	40	15.0-14.5
ER32-16.0	33	40	16.0-15.5
ER32-17.0	33	40	17.0-16.5
ER32-18.0	33	40	18.0-17.5
ER32-19.0	33	40	19.0-18.5
ER32-20.0	33	40	20.0-19.5
ER32 18pc. Collet Set	-	-	-
ER40 (Metric)			
ER40-3.0	41	46	3.0-2.5
ER40-4.0	41	46	4.0-3.5
ER40-5.0	41	46	5.0-4.5
ER40-6.0	41	46	6.0-5.5
ER40-7.0	41	46	7.0-6.5
ER40-8.0	41	46	8.0-7.5
ER40-9.0	41	46	9.0-8.5
ER40-10.0	41	46	10.0-9.5
ER40-11.0	41	46	11.0-10.5
ER40-12.0	41	46	12.0-11.5
ER40-13.0	41	46	13.0-12.5
ER40-14.0	41	46	14.0-13.5
ER40-15.0	41	46	15.0-14.5
ER40-16.0	41	46	16.0-15.5
ER40-17.0	41	46	17.0-16.5
ER40-18.0	41	46	18.0-17.5
ER40-19.0	41	46	19.0-18.5
ER40-20.0	41	46	20.0-19.5
ER40-21.0	41	46	21.0-20.5
ER40-22.0	41	46	22.0-21.5
ER40-23.0	41	46	23.0-22.5
ER40-24.0	41	46	24.0-23.5
ER40-25.0	41	46	25.0-24.5
ER40-26.0	41	46	26.0-25.5
ER40 23pc. Collet Set	-	-	-

Adapters & Holders





GB Collects - INCH

Dimensions (mm)				Product Code					
Shank d (in)	Square SW (in)	I2 (mm)	Pipe Tap	ER11-GB	ER16-GB	ER20-GB	ER25-GB	ER32-GB	ER40-GB
0.141	0.11	18		ER110141GB	ER160141GB				
0.168	0.131	18			ER160168GB	ER200168GB	ER250168GB	ER320168GB	
0.194	0.152	18			ER160194GB	ER200194GB	ER250194GB	ER320194GB	
0.22	0.165	18			ER160220GB	ER200220GB	ER250220GB	ER320220GB	
0.255	0.191	18			ER160255GB	ER200255GB	ER250255GB	ER320255GB	ER400255GB
0.318	0.238	22			ER160318GB	ER200318GB	ER250318GB	ER320318GB	ER400318GB
0.323	0.242	22				ER200323GB	ER250323GB	ER320323GB	ER400323GB
0.367	0.275	22				ER200367GB	ER250367GB	ER320367GB	ER400367GB
0.381	0.286	22				ER200381GB	ER250381GB	ER320381GB	ER400381GB
0.429	0.322	25					ER250429GB	ER320429GB	ER400429GB
0.437	0.328	25	3				ER250437GB	ER320437GB	ER400437GB
0.48	0.36	25					ER250480GB	ER320480GB	ER400480GB
0.5542	0.406	25						ER320542GB	ER400542GB
0.562	0.421	25	3					ER320562GB	ER400562GB
0.59	0.442	25						ER320590GB	ER400592GB
0.652	0.489	25						ER320652GB	ER400652GB
0.687	0.515	25	3						ER400687GB
0.697	0.523	25							ER400697GB
0.7	0.531	25	3						ER400700GB
0.76	0.57	25							ER400760GB
0.8	0.6	28							ER400800GB

GB Collects - METRIC

Dimensions (mm)				Product Code					
Shank d (mm)	Square SW (mm)	I2 (mm)	STD	ER11-GB	ER16-GB	ER20-GB	ER25-GB	ER32-GB	ER40-GB
2.8	2.1	12	DIN	ER11280GB					
3.5	2.7	14	DIN	ER11350GB					
4	3	14	DIN	ER11400GB					
4	3.15/3.2	18	ISO,JIS	ER11450GB	ER16400GB	ER20400GB	ER25400GB	ER32400GB	
4.5	3.4	18	DIN	ER11600GB	ER16450GB	ER20450GB	ER25450GB	ER32450GB	
5	4	18	ISO,JIS		ER16550GB-JIS	ER20550GB-JIS	ER25550GB-JIS	ER32550GB-JIS	
5.5	4.3	18	DIN		ER16550GB	ER20550GB	ER25550GB	ER32550GB	
5.5	4.5	18	JIS		ER16550GB	ER20550GB	ER25550GB	ER32550GB	
6	4.5	18	JIS		ER16600GB	ER20600GB	ER25600GB	ER32600GB	ER40600GB-JIS
6	4.9	18	DIN		ER16600GB-JIS	ER20600GB-JIS	ER25600GB-JIS	ER32600GB-JIS	ER40600GB-DIN
6.2	5	18	JIS		ER16620GB-JIS	ER20620GB-JIS	ER25620GB-JIS	ER32620GB-JIS	ER40620GB
6.3	5	18	ISO,JIS		ER16630GB	ER20630GB	ER25630GB	ER32630GB	ER40630GB
7	5.5	18	DIN, JIS		ER16700GB	ER20700GB	ER25700GB	ER32700GB	ER40700GB
7.1	5.6	18	ISO,JIS		ER16710GB	ER20710GB	ER25710GB	ER32710GB	ER40710GB
8	6.2/6.3	22	DIN,ISO		ER16800GB	ER20800GB	ER25800GB	ER32800GB	ER40800GB
8.5	6.5	22	JIS		ER16850GB-JIS	ER20850GB-JIS	ER25850GB-JIS	ER32850GB-JIS	ER40850GB
9	7.0/7.1	22	DIN,ISO		ER16900GB	ER20900GB	ER25900GB	ER32900GB	ER40900GB
10	8	25	DIN,ISO			ER2010.00GB	ER2510.00GB	ER3210.00GB	ER4010.00GB
10.5	8	25	JIS			ER2010.50GB-JIS	ER2510.50GB-JIS	ER3210.50GB	ER4010.50GB
11	9	25	DIN			ER2011.00GB	ER2511.00GB	ER3211.00GB	ER4011.00GB
1.2	9	25	ISO			ER2011.20GB	ER2511.20GB	ER3211.20GB	ER4011.20GB
12	9	25	DIN				ER2512.00GB	ER3212.00GB	ER4012.00GB
12.5	10	25	ISO,JIS				ER2512.50GB	ER3212.50GB	ER4012.50GB
14	11.0/11.2	25	DIN,JIS,ISO				ER2514.00GB	ER3214.00GB	ER4014.00GB
15	12	25	JIS				ER2515.00GB-JIS	ER3215.00GB	ER4015.00GB
16	12	25	DIN				ER2516.00GB	ER3216.00GB	ER4016.00GB
17	13	25	JIS					ER3217.00GB	ER4017.00GB
18	14.0/14.5	25	DIN,ISO					ER3218.00GB	ER4018.00GB
20	16	28	DIN,ISO					ER3220.00GB	ER4020.00GB
22	18	28	DIN						ER4022.00GB



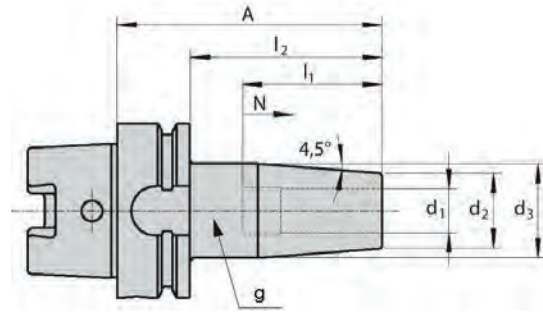

HSK-A63 | ThermoGrip® Standard - INCH

Catalog Number	Dimensions (inch)						
	d ₁	A	d ₂	d ₃	l ₁	N	g
STANDARD PROJECTION							
ST0318-80-HSKA63	0.125	3.15	0.83	1.06	1.42	0.39	M6
ST0476-80-HSKA63	0.187	3.15	0.83	1.06	1.42	0.39	M6
ST0635-80-HSKA63	0.250	3.15	0.83	1.06	1.42	0.39	M5
ST0953-85-HSKA63	0.375	3.34	0.95	1.26	1.65	0.39	M8x1
ST1270-90-HSKA63	0.500	3.54	1.06	1.34	1.85	0.39	M10x1
ST1588-95-HSKA63	0.625	3.74	1.06	1.34	1.97	0.39	M12x1
ST1905-100-HSKA63	0.750	3.94	1.30	1.65	2.05	0.39	M16x1
LONG PROJECTION							
ST0318-120-HSKA63	0.125	4.72	0.83	1.06	1.42	0.39	M6
ST0476-120-HSKA63	0.187	4.72	0.83	1.06	1.42	0.39	M6
ST0635-120-HSKA63	0.250	4.72	0.83	1.06	1.42	0.39	M5
ST0953-120-HSKA63	0.375	4.72	0.95	1.26	1.65	0.39	M8x1
ST1270-120-HSKA63	0.500	4.72	1.06	1.34	1.85	0.39	M10x1
ST1588-120-HSKA63	0.625	4.72	1.06	1.34	1.97	0.39	M12x1
ST2540-120-HSKA63	1.000	4.72	1.73	2.09	2.44	0.39	M16x1
ST3175-120-HSKA63	1.250	4.72	1.73	2.09	2.28	0.39	M16x1
EXTRA LONG PROJECTION							
ST0318-160-HSKA63	0.125	6.30	0.83	1.26	1.42	0.39	M6
ST0476-160-HSKA63	0.187	6.30	0.83	1.26	1.42	0.39	M6
ST0635-160-HSKA63	0.250	6.30	0.83	1.26	1.42	0.39	M5
ST0953-160-HSKA63	0.375	6.30	0.95	1.34	1.65	0.39	M8x1
ST1270-160-HSKA63	0.500	6.30	1.06	1.65	1.85	0.39	M10x1
ST1588-160-HSKA63	0.625	6.30	1.06	1.65	1.97	0.39	M12x1
ST1905-160-HSKA63	0.750	6.30	1.30	2.01	2.05	0.39	M16x1
ST2540-160-HSKA63	1.000	6.30	1.73	2.09	2.44	0.39	M16x1
ST3175-160-HSKA63	1.250	6.30	1.73	2.09	2.28	0.39	M16x1

All holders can be run with internal coolant
 Please Order Coolant Tube separately
 NOTE: Tool Shank Tolerance must be h6 or better, h4 for holders with ID smaller than 5mm

HSK-A63 | ThermoGrip® Standard - METRIC

Catalog Number	Dimensions (mm)						
	d ₁	A	d ₂	d ₃	l ₁	N	g
STANDARD PROJECTION							
ST0300-80-HSKA63	3	80	15	20	20	5	M6
ST0400-80-HSKA63	4	80	15	20	20	5	M6
ST0500-80-HSKA63	5	80	15	20	25	5	M6
ST0600-80-HSKA63	6	80	21	27	36	10	M5
ST0800-80-HSKA63	8	80	21	27	36	10	M6
ST1000-85-HSKA63	10	85	24	32	42	10	M8x1
ST1200-90-HSKA63	12	90	24	32	47	10	M10x1
ST1400-90-HSKA63	14	90	27	34	47	10	M10x1
ST1600-95-HSKA63	16	95	27	34	50	10	M12x1
ST1800-95-HSKA63	18	95	33	42	50	10	M12x1
ST2000-100-HSKA63	20	100	33	42	52	10	M16x1
ST2500-115-HSKA63	25	115	44	53	58	10	M16x1
LONG PROJECTION							
ST0600-120-HSKA63	6	120	21	27	36	10	M5
ST0800-120-HSKA63	8	120	21	27	36	10	M6
ST1000-120-HSKA63	10	120	24	32	42	10	M8x1
ST1200-120-HSKA63	12	120	24	32	47	10	M10x1
ST1400-120-HSKA63	14	120	27	34	47	10	M10x1
ST1600-120-HSKA63	16	120	27	34	50	10	M12x1
ST1800-120-HSKA63	18	120	33	42	50	10	M12x1
ST2000-120-HSKA63	20	120	33	42	52	10	M16x1
ST3200-120-HSKA63	32	120	44	53	58	10	M16x1
EXTRA LONG PROJECTION							
ST0600-160-HSKA63	6	160	21	32	36	10	M5
ST0800-160-HSKA63	8	160	21	32	36	10	M6
ST1000-160-HSKA63	10	160	24	34	42	10	M8x1
ST1200-160-HSKA63	12	160	24	34	47	10	M10x1
ST1400-160-HSKA63	14	160	27	42	47	10	M10x1
ST1600-160-HSKA63	16	160	27	42	50	10	M12x1
ST1800-160-HSKA63	18	160	33	51	50	10	M12x1
ST2000-160-HSKA63	20	160	33	51	52	10	M16x1
ST2500-160-HSKA63	25	160	44	53	58	10	M16x1
ST3200-160-HSKA63	32	160	44	53	62	10	M16x1

All holders can be run with internal coolant
 Please Order Coolant Tube Catalog separately
 NOTE: Tool Shank Tolerance must be h6 or better, h4 for holders with ID smaller than 5mm



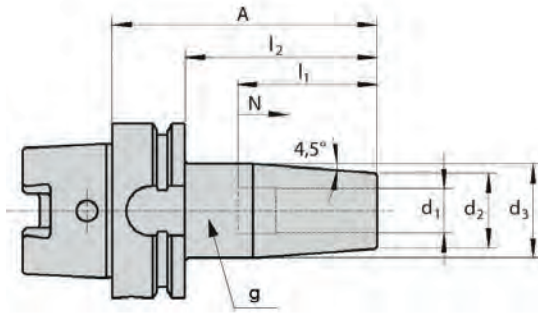

Adapters & Holders

HSK-A100 ThermoGrip® Standard-INCH							
Catalog Number	Dimensions (inch)						
	d ₁	A	d ₂	d ₃	l ₁	N	g
STANDARD PROJECTION							
ST0635-85-HSKA100	0.250	3.35	0.83	1.06	1.42	0.39	M5
ST0953-90-HSKA100	0.375	3.54	0.94	1.26	1.65	0.39	M8X1
ST1270-95-HSKA100	0.500	3.74	1.06	1.34	1.85	0.39	M10X1
ST1588-95-HSKA100	0.625	3.94	1.06	1.34	1.97	0.39	M12X1
ST1905-105-HSKA100	0.750	4.13	1.30	1.65	2.05	0.39	M16X1
LONG PROJECTION							
ST0635-120-HSKA100	0.250	4.72	0.83	1.06	1.42	0.39	M5
ST0953-120-HSKA100	0.375	4.72	0.94	1.26	1.65	0.39	M8X1
ST1270-120-HSKA100	0.500	4.72	1.06	1.34	1.85	0.39	M10X1
ST1588-120-HSKA100	0.625	4.72	1.06	1.34	1.97	0.39	M12X1
ST1905-120-HSKA100	0.750	4.72	1.30	1.65	2.05	0.39	M16X1
ST2540-120-HSKA100	1.000	4.72	1.73	2.09	2.44	0.39	M16X1
ST3175-120-HSKA100	1.250	4.72	1.73	2.09	2.44	0.39	M16X1
EXTRA LONG PROJECTION							
ST0635-160-HSKA100	0.250	6.30	0.83	1.26	1.42	0.39	M5
ST0953-160-HSKA100	0.375	6.30	0.94	1.34	1.65	0.39	M8X1
ST1270-160-HSKA100	0.500	6.30	1.06	1.65	1.85	0.39	M10X1
ST1588-160-HSKA100	0.625	6.30	1.06	1.65	1.97	0.39	M12X1
ST1905-160-HSKA100	0.750	6.30	1.30	2.01	2.05	0.39	M16X1
ST2540-160-HSKA100	1.000	6.30	1.73	2.36	2.44	0.39	M16X1

All holders can be run with internal coolant
 Please Order Coolant Tube separately
 NOTE: Tool Shank Tolerance must be h6 or better, h4 for holders with ID smaller than 5mm

HSK-A100 ThermoGrip® Standard-METRIC							
Catalog Number	Dimensions (mm)						
	d ₁	A	d ₂	d ₃	l ₁	N	g
STANDARD PROJECTION							
ST0600-85-HSKA100	6	85	21	27	36	10	M5
ST0800-85-HSKA100	8	85	21	27	36	10	M6
ST1000-90-HSKA100	10	90	24	32	42	10	M8x1
ST1200-95-HSKA100	12	95	24	32	47	10	M10x1
ST1400-95-HSKA100	14	95	27	34	50	10	M10x1
ST1600-100-HSKA100	16	100	27	34	50	10	M12x1
ST1800-100-HSKA100	18	100	33	42	50	10	M12x1
ST2000-105-HSKA100	20	105	33	42	52	10	M16x1
ST2500-115-HSKA100	25	115	44	53	58	10	M16x1
LONG PROJECTION							
ST0600-120-HSKA100	6	120	21	27	36	10	M5
ST0800-120-HSKA100	8	120	21	27	36	10	M6
ST1000-120-HSKA100	10	120	24	32	42	10	M8x1
ST1200-120-HSKA100	12	120	24	32	47	10	M10x1
ST1400-120-HSKA100	14	120	27	34	50	10	M10x1
ST1600-120-HSKA100	16	120	27	34	50	10	M12x1
ST1800-120-HSKA100	18	120	33	42	50	10	M12x1
ST2000-120-HSKA100	20	120	33	42	52	10	M16x1
ST2500-120-HSKA100	25	120	44	53	58	10	M16x1
ST3200-120-HSKA100	32	120	44	53	62	10	M16x1
EXTRA LONG PROJECTION							
ST0600-160-HSKA100	6	160	21	32	36	10	M5
ST0800-160-HSKA100	8	160	21	32	36	10	M6
ST1000-160-HSKA100	10	160	24	34	42	10	M8x1
ST1200-160-HSKA100	12	160	24	34	47	10	M10x1
ST1400-160-HSKA100	14	160	27	42	47	10	M10x1
ST1600-160-HSKA100	16	160	27	42	50	10	M12x1
ST1800-160-HSKA100	18	160	33	51	52	10	M12x1
ST2000-160-HSKA100	20	160	33	51	52	10	M16x1
ST2500-160-HSKA100	25	160	44	53	58	10	M16x1
ST3200-160-HSKA100	32	160	44	53	62	10	M16x1

All holders can be run with internal coolant
 Please Order Coolant Tube separately
 NOTE: Tool Shank Tolerance must be h6 or better, h4 for holders with ID smaller than 5mm



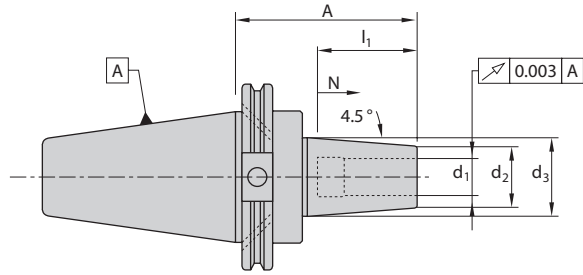

CAT40 | ThermoGrip® Standard-INCH

Catalog Number	Dimensions (inch)						
	d ₁	A	d ₂	d ₃	I ₁	N	g
STANDARD PROJECTION							
ST0318-95-CAT40	0.125	3.74	0.59	0.79	0.79	0.20	M6
ST0476-95-CAT40	0.187	3.74	0.59	0.79	0.79	0.20	M6
ST0635-95-CAT40	0.250	3.74	0.83	1.06	1.42	0.39	M5
ST0953-95-CAT40	0.375	3.74	0.95	1.26	1.65	0.39	M8x1
ST1270-95-CAT40	0.500	3.74	1.06	1.34	1.85	0.39	M10x1
ST1588-95-CAT40	0.625	3.74	1.06	1.34	1.97	0.39	M12x1
ST1905-95-CAT40	0.750	3.74	1.30	1.65	2.05	0.39	M16x1
ST2540-100-CAT40	1.000	3.94	1.73	2.09	2.44	0.39	M16x1
ST3175-100-CAT40	1.250	3.94	1.73	2.09	2.44	0.39	M16x1
LONG PROJECTION							
ST0318-120-CAT40	0.125	4.73	0.59	0.79	0.79	0.20	M6
ST0476-120-CAT40	0.187	4.73	0.59	0.79	0.79	0.20	M6
ST0635-120-CAT40	0.250	4.73	0.83	1.06	1.42	0.39	M5
ST0953-120-CAT40	0.375	4.73	0.95	1.26	1.65	0.39	M8x1
ST1270-120-CAT40	0.500	4.73	1.06	1.34	1.85	0.39	M10x1
ST1588-120-CAT40	0.625	4.73	1.06	1.34	1.97	0.39	M12x1
ST1905-120-CAT40	0.750	4.73	1.30	1.65	2.05	0.39	M16x1
ST2540-120-CAT40	1.000	4.73	1.73	2.09	2.44	0.39	M16x1
ST3175-120-CAT40	1.25	4.73	1.73	2.09	2.44	0.39	M16x1
EXTRA LONG PROJECTION							
ST0318-160-CAT40	0.125	6.30	0.59	0.79	0.79	0.20	M6
ST0476-160-CAT40	0.187	6.30	0.59	0.79	0.79	0.20	M6
ST0635-160-CAT40	0.250	6.30	0.83	1.26	1.42	0.39	M5
ST0953-160-CAT40	0.375	6.30	0.95	1.34	1.65	0.39	M8x1
ST1270-160-CAT40	0.500	6.30	1.06	1.65	1.85	0.39	M10x1
ST1588-160-CAT40	0.625	6.30	1.06	1.65	1.97	0.39	M12x1
ST1905-160-CAT40	0.750	6.30	1.30	1.75	2.05	0.39	M16x1
ST2540-160-CAT40	1.000	6.30	1.73	2.09	2.44	0.39	M16x1
ST3175-160-CAT40	1.250	6.30	1.73	2.09	2.44	0.39	M16x1

CAT40 | ThermoGrip® Standard-METRIC

Catalog Number	Dimensions (mm)						
	d ₁	A	d ₂	d ₃	I ₁	N	g
STANDARD PROJECTION							
ST0300-95-CAT40	3	95	15	20	20	5	M6
ST0400-95-CAT40	4	95	15	20	20	5	M6
ST0500-95-CAT40	5	95	15	20	25	5	M6
ST0600-95-CAT40	6	95	21	27	36	10	M5
ST0800-95-CAT40	8	95	21	27	36	10	M6
ST1000-95-CAT40	10	95	24	32	42	10	M8x1
ST1200-95-CAT40	12	95	24	32	47	10	M10x1
ST1400-95-CAT40	14	95	27	34	47	10	M10x1
ST1600-95-CAT40	16	95	27	34	50	10	M12x1
ST1800-95-CAT40	18	95	33	42	50	10	M12x1
ST2000-95-CAT40	20	95	33	42	52	10	M16x1
ST2500-100-CAT40	25	100	44	53	58	10	M16x1
ST3200-100-CAT40	32	100	44	53	62	10	M16x1
LONG PROJECTION							
ST0600-120-CAT40	6	120	21	27	36	10	M5
ST0800-120-CAT40	8	120	21	27	36	10	M6
ST1000-120-CAT40	10	120	24	32	42	10	M8x1
ST1200-120-CAT40	12	120	24	32	47	10	M10x1
ST1400-120-CAT40	14	120	27	34	47	10	M10x1
ST1600-120-CAT40	16	120	27	34	50	10	M12x1
ST1800-120-CAT40	18	120	33	42	50	10	M12x1
ST2000-120-CAT40	20	120	33	42	52	10	M16x1
ST2500-120-CAT40	25	120	44	53	58	10	M16x1
ST3200-120-CAT40	32	120	44	53	62	10	M16x1
EXTRA LONG PROJECTION							
ST0600-160-CAT40	6	160	21	32	36	10	M5
ST0800-160-CAT40	8	160	21	32	36	10	M6
ST1000-160-CAT40	10	160	24	34	42	10	M8x1
ST1200-160-CAT40	12	160	24	34	47	10	M10x1
ST1400-160-CAT40	14	160	27	42	47	10	M10x1
ST1600-160-CAT40	16	160	27	42	50	10	M12x1
ST1800-160-CAT40	18	160	33	44	50	10	M12x1
ST2000-160-CAT40	20	160	44	53	52	10	M16x1
ST2500-160-CAT40	25	160	44	53	58	10	M16x1
ST3200-160-CAT40	32	160	44	53	62	10	M16x1

NOTE: All Holders Have 5-8-11 UNC Thread for Retention Knob & DIN FORM B Flange Coolant Delivery Option Standard

NOTE: Tool Shank Tolerance must be h6 or better, h4 for holders with ID smaller than 5mm



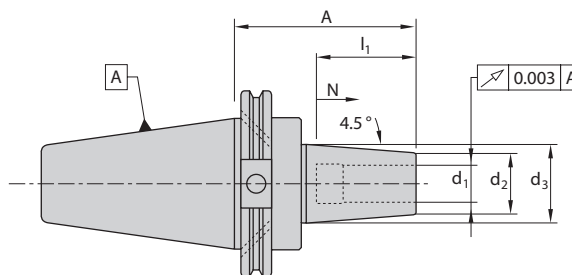

CAT50 ThermoGrip® Standard-INCH							
Catalog Number	Dimensions (inch)						
	d ₁	A	d ₂	d ₃	I ₁	N	g
STANDARD PROJECTION							
ST0635-95-CAT50	0.250	3.74	0.83	1.06	1.42	0.39	M5
ST0953-95-CAT50	0.375	3.74	0.95	1.26	1.65	0.39	M8x1
ST1270-95-CAT50	0.500	3.74	1.06	1.34	1.85	0.39	M10x1
ST1588-95-CAT50	0.625	3.74	1.06	1.34	1.97	0.39	M12x1
ST1905-95-CAT50	0.750	3.74	1.30	1.65	2.05	0.39	M16x1
ST2540-105-CAT50	1.000	4.13	1.73	2.09	2.44	0.39	M16x1
ST3175-105-CAT50	1.250	4.13	1.73	2.09	2.44	0.39	M16x1
EXTRA LONG PROJECTION							
ST0635-160-CAT50	0.250	6.30	0.83	1.26	1.42	0.39	M5
ST0953-160-CAT50	0.375	6.30	0.95	1.34	1.65	0.39	M8x1
ST1270-160-CAT50	0.500	6.30	1.06	1.65	1.85	0.39	M10x1
ST1588-160-CAT50	0.625	6.30	1.06	1.65	1.97	0.39	M12x1
ST1905-160-CAT50	0.750	6.30	1.30	2.01	2.05	0.39	M16x1
ST2540-160-CAT50	1.000	6.30	1.73	2.36	2.44	0.39	M16x1
ST3175-160-CAT50	1.250	6.30	1.73	2.36	2.44	0.39	M16x1

NOTE: All Holders Have 1-8 UNC Thread for Retention Knob & DIN FORM B Flange Coolant Delivery Option-Standard

NOTE: Tool Shank Tolerance must be h6 or better, h4 for holders with ID smaller than 5mm

CAT50 ThermoGrip® Standard-METRIC							
Catalog Number	Dimensions (mm)						
	d ₁	A	d ₂	d ₃	I ₁	N	g
STANDARD PROJECTION							
ST0600-95-CAT50	6	95	21	27	36	10	M5
ST0800-95-CAT50	8	95	21	27	36	10	M6
ST1000-95-CAT50	10	95	24	32	42	10	M8x1
ST1200-95-CAT50	12	95	24	32	47	10	M10x1
ST1400-95-CAT50	14	95	27	34	47	10	M10x1
ST1600-95-CAT50	16	95	27	34	50	10	M12x1
ST1800-95-CAT50	18	95	33	42	50	10	M12x1
ST2000-95-CAT50	20	95	33	42	52	10	M16x1
ST2500-105-CAT50	25	105	44	53	58	10	M16x1
ST3200-105-CAT50	32	105	44	53	62	10	M16x1
EXTRA LONG PROJECTION							
ST0600-160-CAT50	6	160	21	32	36	10	M5
ST0800-160-CAT50	8	160	21	32	36	10	M6
ST1000-160-CAT50	10	160	24	34	42	10	M8x1
ST1200-160-CAT50	12	160	24	34	47	10	M10x1
ST1400-160-CAT50	14	160	27	42	47	10	M10x1
ST1600-160-CAT50	16	160	27	42	50	10	M12x1
ST1800-160-CAT50	18	160	33	51	50	10	M12x1
ST2000-160-CAT50	20	160	33	51	52	10	M16x1
ST2500-160-CAT50	25	160	44	60	58	10	M16x1
ST3200-160-CAT50	32	160	44	60	62	10	M16x1

NOTE: All Holders Have 1-8 UNC Thread for Retention Knob & DIN FORM B Flange Coolant Delivery Option-Standard

NOTE: Tool Shank Tolerance must be h6 or better, h4 for holders with ID smaller than 5mm





This processor controlled ISG3400TWK unit is simple to use. All that needs to be done is to select the tool diameter range. After the induction coil is positioned around the tool holder, push the start button and the coil heats the tool holder sufficiently. When heat cycle is completed, move the coil upward away from tool. Raise the cooling sleeve and press the cooling button, allowing the tool to cool in seconds.

ISG3400TWK: It is universal shrinking unit for the professional use of shrinking technology. With its unique coil changing system, the power transfer adjusted to different clamping chucks is guaranteed within a short period of time. Compared to other systems, this makes it possible to clamp the smallest diameter tools. This allows for a constant preparation of a high number of tools. Guaranteed.

ThermoGrip® Machine: ISG3400TWK-WS			
Catalog No.	ISG3400TWK	Max Tool Length	400mm 15.75"
Dimensions D x W x H	800mm x 560mm x 950mm 31.5" x 22" x 38"	Max Cooling Length	160mm 6.3"
Clamping Range SC	6-32mm 1/8"-1-1/4"	Cooling Type	Liquid/ emulsion
Clamping Range HSS	6-32mm 1/4"-1-1/4"	Cooling Time	20 Seconds
Coil	Quick Change	Geometry Independent Cooling	Yes
Electric Current Supply	3x480V-16A	Max Machine Interface	HSK 100 CAT50
Power kW	11 kW	Required Accessories	setting pot
Weight	115 lbs	Optional Accessories	setting pot



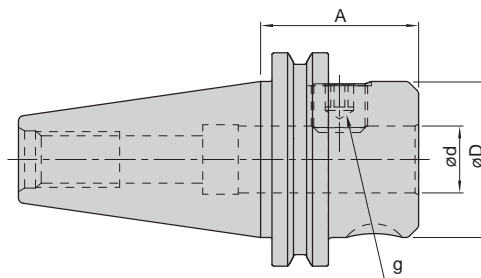

CAT40 Balanced to G6.3 @ 8,000 RPM				
Catalog Number	Dimensions			
	d (inch)	D (mm)	A (inch)	g
SSEH-0.125-1.38-CAT40	0.125	17.5	1.38	6-32 UNC
SSEH-0.125-4.50-CAT40	0.125	17.5	4.50	6-32 UNC
SSEH-0.187-1.38-CAT40	0.187	17.5	1.38	8-32 UNC
SSEH-0.187-2.50-CAT40	0.187	17.5	2.50	8-32 UNC
SSEH-0.187-4.50-CAT40	0.187	17.5	4.50	8-32 UNC
SSEH-0.250-1.38-CAT40	0.250	19.8	1.38	1-4-28 UNF
SSEH-0.250-2.50-CAT40	0.250	19.8	2.50	1-4-28 UNF
SSEH-0.250-4.50-CAT40	0.250	19.8	4.50	1-4-28 UNF
SSEH-0.312-1.38-CAT40	0.312	25.4	1.38	5-16-24 UNF
SSEH-0.312-2.50-CAT40	0.312	25.4	2.50	5-16-24 UNF
SSEH-0.312-4.50-CAT40	0.312	25.4	4.50	5-16-24 UNF
SSEH-0.375-1.38-CAT40	0.375	25.4	1.38	3-8-24 UNF
SSEH-0.375-2.50-CAT40	0.375	25.4	2.50	3-8-24 UNF
SSEH-0.375-4.50-CAT40	0.375	25.4	4.50	3-8-24 UNF
SSEH-0.375-6.50-CAT40	0.375	25.4	6.50	3-8-24 UNF
SSEH-0.437-1.75-CAT40	0.437	35.1	1.75	7-16-20 UNF
SSEH-0.437-4.50-CAT40	0.437	35.1	4.50	7-16-20 UNF
SSEH-0.500-1.75-CAT40	0.500	35.1	1.75	7-16-20 UNF
SSEH-0.500-2.62-CAT40	0.500	35.1	2.62	7-16-20 UNF
SSEH-0.500-4.62-CAT40	0.500	35.1	4.62	7-16-20 UNF
SSEH-0.500-6.62-CAT40	0.500	35.1	6.62	7-16-20 UNF
SSEH-0.625-1.75-CAT40	0.625	38.1	1.75	1-2-20 UNF
SSEH-0.625-3.75-CAT40	0.625	38.1	3.75	1-2-20 UNF
SSEH-0.625-5.75-CAT40	0.625	38.1	5.75	1-2-20 UNF
SSEH-0.750-1.75-CAT40	0.750	44.5	1.75	5-8-18 UNF
SSEH-0.750-3.75-CAT40	0.750	44.5	3.75	5-8-18 UNF
SSEH-0.750-5.75-CAT40	0.750	44.5	5.75	5-8-18 UNF
SSEH-0.875-1.75-CAT40	0.875	50.8	1.75	5-8-18 UNF
SSEH-0.875-4.00-CAT40	0.875	50.8	4.00	5-8-18 UNF
SSEH-0.875-6.00-CAT40	0.875	50.8	6.00	5-8-18 UNF
SSEH-1.000-1.75-CAT40	1.000	50.8	1.75	3-4-16 UNF
SSEH-1.000-4.00-CAT40	1.000	50.8	4.00	3-4-16 UNF
SSEH-1.000-6.00-CAT40	1.000	50.8	6.00	3-4-16 UNF
SSEH-1.250-2.00-CAT40	1.250	63.5	2.00	3-4-16 UNF
SSEH-1.250-4.25-CAT40	1.250	63.5	4.25	3-4-16 UNF
SSEH-1.250-6.25-CAT40	1.250	63.5	6.25	3-4-16 UNF
SSEH-1.500-4.62-CAT40	1.500	69.9	4.62	3-4-16 UNF
SSEH-1.500-6.62-CAT40	1.500	69.9	6.62	3-4-16 UNF

CAT50 Balanced to G6.3 @ 8,000 RPM				
Catalog Number	Dimensions			
	d (inch)	D (mm)	A (inch)	g
SSEH-0.187-2.50-CAT50	0.187	17.5	2.50	8-32 UNC
SSEH-0.187-4.50-CAT50	0.187	17.5	4.50	8-32 UNC
SSEH-0.187-6.50-CAT50	0.187	17.5	6.50	8-32 UNC
SSEH-0.250-2.50-CAT50	0.250	19.8	2.50	1-4-28 UNF
SSEH-0.250-4.50-CAT50	0.250	19.8	4.50	1-4-28 UNF
SSEH-0.250-6.50-CAT50	0.250	19.8	6.50	1-4-28 UNF
SSEH-0.312-2.50-CAT50	0.312	25.4	2.50	5-16-24 UNF
SSEH-0.312-4.50-CAT50	0.312	25.4	4.50	5-16-24 UNF
SSEH-0.312-6.50-CAT50	0.312	25.4	6.50	5-16-24 UNF
SSEH-0.375-2.50-CAT50	0.375	25.4	2.50	3-8-24 UNF
SSEH-0.375-4.50-CAT50	0.375	25.4	4.50	3-8-24 UNF
SSEH-0.375-6.50-CAT50	0.375	25.4	6.50	3-8-24 UNF
SSEH-0.375-8.50-CAT50	0.375	25.4	8.50	3-8-24 UNF
SSEH-0.437-2.50-CAT50	0.437	35.1	2.50	7-16-20 UNF
SSEH-0.500-2.62-CAT50	0.500	35.1	2.62	7-16-20 UNF
SSEH-0.500-4.62-CAT50	0.500	35.1	4.62	7-16-20 UNF
SSEH-0.500-6.62-CAT50	0.500	35.1	6.62	7-16-20 UNF
SSEH-0.500-8.50-CAT50	0.500	35.1	8.50	7-16-20 UNF
SSEH-0.625-3.75-CAT50	0.625	38.1	3.75	1-2-20 UNF
SSEH-0.625-5.75-CAT50	0.625	38.1	5.75	1-2-20 UNF
SSEH-0.625-7.75-CAT50	0.625	38.1	7.75	1-2-20 UNF
SSEH-0.750-3.75-CAT50	0.750	44.5	3.75	5-8-18 UNF
SSEH-0.750-5.75-CAT50	0.750	44.5	5.75	5-8-18 UNF
SSEH-0.750-7.75-CAT50	0.750	44.5	7.75	5-8-18 UNF
SSEH-0.750-10.00-CAT50	0.750	44.5	10.00	5-8-18 UNF
SSEH-0.875-3.75-CAT50	0.875	50.8	3.75	5-8-18 UNF
SSEH-0.875-5.75-CAT50	0.875	50.8	5.75	5-8-18 UNF
SSEH-0.875-7.75-CAT50	0.875	50.8	7.75	5-8-18 UNF
SSEH-1.000-4.00-CAT50	1.000	50.8	4.00	3-4-16 UNF
SSEH-1.000-6.00-CAT50	1.000	50.8	6.00	3-4-16 UNF
SSEH-1.000-8.00-CAT50	1.000	50.8	8.00	3-4-16 UNF
SSEH-1.000-10.00-CAT50	1.000	50.8	10.00	3-4-16 UNF
SSEH-1.250-4.00-CAT50	1.250	63.5	4.00	3-4-16 UNF
SSEH-1.250-6.00-CAT50	1.250	63.5	6.00	3-4-16 UNF
SSEH-1.250-8.00-CAT50	1.250	63.5	8.00	3-4-16 UNF
SSEH-1.250-10.00-CAT50	1.250	63.5	10.00	3-4-16 UNF
SSEH-1.500-4.00-CAT50	1.500	69.9	4.00	3-4-16 UNF
SSEH-1.500-6.00-CAT50	1.500	69.9	6.00	3-4-16 UNF
SSEH-1.500-8.00-CAT50	1.500	69.9	8.00	3-4-16 UNF
SSEH-2.000-5.62-CAT50	2.000	95.3	5.62	1-14 UNS
SSEH-2.000-9.62-CAT50	2.000	95.3	9.62	1-14 UNS



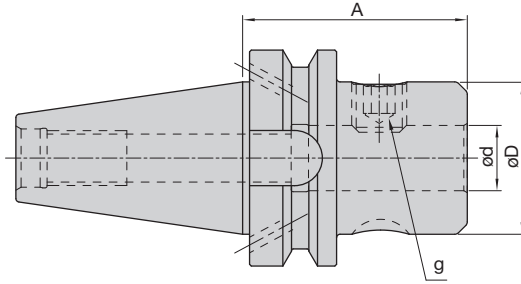

BT30 Balanced to G6.3 @ 8,000 RPM				
Catalog Number	Dimensions			
	d (inch)	D (mm)	A (inch)	g
SSEH-0.125-2.36-BT30	0.125	17.5	2.36	6-32 UNC
SSEH-0.188-2.36-BT30	0.187	17.5	2.36	8-32 UNC
SSEH-0.250-2.36-BT30	0.250	19.8	2.36	1-4-28 UNF
SSEH-0.312-2.36-BT30	0.312	25.4	2.36	5-16-24 UNF
SSEH-0.375-2.36-BT30	0.375	25.4	2.36	3-8-24 UNF
SSEH-0.500-2.36-BT30	0.500	35.1	2.36	7-16-20 UNF
SSEH-0.625-2.36-BT30	0.625	38.1	2.36	1-2-20 UNF
SSEH-0.750-2.36-BT30	0.750	44.5	2.36	5-8-18 UNF

BT40 Balanced to G6.3 @ 8,000 RPM				
Catalog Number	Dimensions			
	d (inch)	D (mm)	A (inch)	g
SSEH-0.250-2.55-BT40	0.250	19.8	2.55	1-4-28 UNF
SSEH-0.312-2.55-BT40	0.312	25.4	2.55	5-16-24 UNF
SSEH-0.375-2.55-BT40	0.375	25.4	2.55	3-8-24 UNF
SSEH-0.500-2.55-BT40	0.500	35.1	2.55	7-16-20 UNF
SSEH-0.500-4.00-BT40	0.500	35.1	4.00	7-16-20 UNF
SSEH-0.625-2.55-BT40	0.625	38.1	2.55	1-2-20 UNF
SSEH-0.750-2.55-BT40	0.750	44.5	2.55	5-8-18 UNF
SSEH-0.875-3.35-BT40	0.875	50.8	3.35	5-8-18 UNF
SSEH-1.000-3.74-BT40	1.000	50.8	3.74	3-4-16 UNF
SSEH-1.000-5.00-BT40	1.000	50.8	5.00	3-4-16 UNF
SSEH-1.250-3.35-BT40	1.250	63.5	3.35	3-4-16 UNF

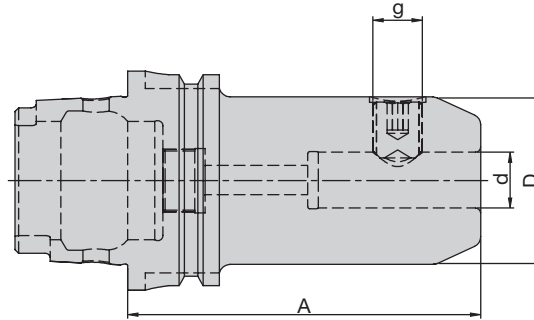

HSK-A63 End Mill Holder Balanced to G6.3 @ 20,000 RPM				
Catalog Number	Dimensions			
	d (inch)	D (inch)	A (inch)	g
SSEH-0.250"-3.94"/HSK-A63	0.250	1.00	3.94	1/4-28UNF
SSEH-0.375"-3.94"/HSK-A63	0.375	1.10	3.94	3/8-24UNF
SSEH-0.500"-3.94"/HSK-A63	0.500	1.65	3.94	7/16-20UNF
SSEH-0.625"-3.94"/HSK-A63	0.625	1.89	3.94	1/2-20UNF
SSEH-0.750"-3.94"/HSK-A63	0.750	2.05	3.94	5/8-18UNF
SSEH-1.00"-4.33"/HSK-A63	1.000	2.60	4.33	3/4-16UNF
SSEH-1.250"-4.33"/HSK-A63	1.250	2.83	4.33	3/4-16UNF

HSK-A100 End Mill Holders Balanced to G6.3 @ 20,000 RPM				
Catalog Number	Dimensions			
	d (inch)	D (inch)	A (inch)	g
SSEH-0.250"-3.15"/HSK-A100	0.250	0.78	3.15"	1/4-28UNF-8
SSEH-0.250"-6.30"/HSK-A100	0.250	0.78	6.30"	1/4-28UNF-8
SSEH-0.312"-3.15"/HSK-A100	0.312	1.00	3.15"	5/16-24UNF-10
SSEH-0.312"-6.30"/HSK-A100	0.312	1.00	6.30"	5/16-24UNF-10
SSEH-0.375"-3.15"/HSK-A100	0.375	1.00	3.15"	3/8-24UNF-9
SSEH-0.375"-6.30"/HSK-A100	0.375	1.00	6.30"	3/8-24UNF-9
SSEH-0.500"-3.15"/HSK-A100	0.500	1.38	3.15"	7/16-20UNF-12
SSEH-0.500"-6.30"/HSK-A100	0.500	1.38	6.30"	7/16-20UNF-12
SSEH-0.625"-3.94"/HSK-A100	0.625	1.50	3.94"	1/2-20UNF-14
SSEH-0.625"-6.30"/HSK-A100	0.625	1.50	6.30"	1/2-20UNF-14
SSEH-0.750"-3.94"/HSK-A100	0.750	1.75	3.94"	5/8-18UNF-14
SSEH-0.750"-6.30"/HSK-A100	0.750	1.75	6.30"	5/8-18UNF-14
SSEH-1.000"-3.94"/HSK-A100	1.000	2.00	3.94"	3/4-16UNF-14
SSEH-1.000"-6.30"/HSK-A100	1.000	2.00	6.30"	3/4-16UNF-14
SSEH-1.250"-3.94"/HSK-A100	1.250	2.50	3.94"	3/4-16UNF-14
SSEH-1.250"-6.30"/HSK-A100	1.250	2.50	6.30"	3/4-16UNF-14



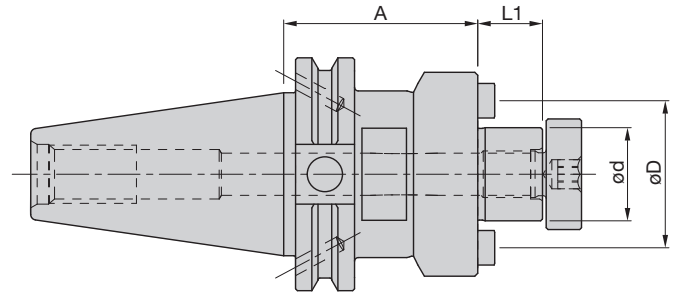

Adapters & Holders

Shell Mill Holders		Balanced to G6.3 @ 8,000 RPM					
Catalog Number	Dimensions						
	d (mm)	d (inch)	D (mm)	A (mm)	A (inch)	L ₁ (mm)	D ₁ (mm)
CAT40							
SSMH-0.500-1.38-CAT40	12.7	0.50	36.6	35.1	1.38	14.2	25.4
SSMH-0.500-3.50-CAT40	12.7	0.50	36.6	88.9	3.50	14.2	25.4
SSMH-0.750-1.38-CAT40	19.1	0.75	44.4	35.1	1.38	17.5	28.7
SSMH-0.750-3.50-CAT40	19.1	0.75	44.4	88.9	3.50	17.5	28.7
SSMH-0.750-6.00-CAT40	19.1	0.75	44.4	152.4	6.00	17.5	28.7
SSMH-1.000-1.75-CAT40	25.4	1.00	55.6	44.5	1.75	17.5	40.1
SSMH-1.000-2.06-CAT40	25.4	1.00	55.6	52.3	2.06	17.5	40.1
SSMH-1.000-4.00-CAT40	25.4	1.00	55.6	101.6	4.00	17.5	40.1
SSMH-1.000-6.00-CAT40	25.4	1.00	55.6	152.4	6.00	17.5	40.1
SSMH-1.250-2.12-CAT40	31.8	1.25	69.9	53.8	2.12	17.5	50.3
SSMH-1.250-4.00-CAT40	31.8	1.25	69.9	101.6	4.00	17.5	50.3
SSMH-1.500-2.41-CAT40	38.1	1.50	85.9	61.2	2.41	23.9	60.7
SSMH-1.500-4.00-CAT40	38.1	1.50	85.9	101.6	4.00	23.9	60.7
CAT50							
SSMH-0.500-1.50-CAT50	12.7	0.50	36.6	38.1	1.50	14.2	25.4
SSMH-0.500-3.50-CAT50	12.7	0.50	36.6	88.9	3.50	14.2	25.4
SSMH-0.500-5.50-CAT50	12.7	0.50	36.6	139.7	5.50	14.2	25.4
SSMH-0.750-1.50-CAT50	19.1	0.75	44.5	38.1	1.50	17.5	28.7
SSMH-0.750-3.50-CAT50	19.1	0.75	44.5	88.9	3.50	17.5	28.7
SSMH-0.750-5.50-CAT50	19.1	0.75	44.5	139.7	5.50	17.5	28.7
SSMH-0.750-7.00-CAT50	19.1	0.75	44.5	177.8	7.00	17.5	28.7
SSMH-0.750-9.00-CAT50	19.1	0.75	44.5	228.6	9.00	17.5	28.7
SSMH-1.000-10.00-CAT50	25.4	1.00	55.6	254.0	10.00	17.5	40.1
SSMH-1.000-2.00-CAT50	25.4	1.00	55.6	50.8	2.00	17.5	40.1
SSMH-1.000-4.00-CAT50	25.4	1.00	55.6	101.6	4.00	17.5	40.1
SSMH-1.000-6.00-CAT50	25.4	1.00	55.6	152.4	6.00	17.5	40.1
SSMH-1.000-8.00-CAT50	25.4	1.00	55.6	203.2	8.00	17.5	40.1
SSMH-1.250-1.50-CAT50	31.8	1.25	69.9	38.1	1.50	17.5	50.3
SSMH-1.250-3.50-CAT50	31.8	1.25	69.9	88.9	3.50	17.5	50.3
SSMH-1.250-5.50-CAT50	31.8	1.25	69.9	139.7	5.50	17.5	50.3
SSMH-1.250-7.00-CAT50	31.8	1.25	69.9	177.8	7.00	17.5	50.3
SSMH-1.250-9.00-CAT50	31.8	1.25	69.9	228.6	9.00	17.5	50.3
SSMH-1.500-2.40-CAT50	38.1	1.50	85.9	61.0	2.40	23.9	60.7
SSMH-1.500-4.00-CAT50	38.1	1.50	85.9	101.6	4.00	23.9	60.7
SSMH-1.500-6.00-CAT50	38.1	1.50	85.9	152.4	6.00	23.9	60.7
SSMH-1.500-8.00-CAT50	38.1	1.50	85.9	203.2	8.00	23.9	60.7
SSMH-2.000-2.40-CAT50	50.8	2.00	123.9	61.0	2.40	23.9	77.2
SSMH-2.000-4.00-CAT50	50.8	2.00	123.9	101.6	4.00	23.9	77.2
SSMH-2.000-6.00-CAT50	50.8	2.00	123.9	152.4	6.00	23.9	77.2
SSMH-2.000-8.00-CAT50	50.8	2.00	123.9	203.2	8.00	23.9	77.2
SSMH-2.500-2.40-CAT50	63.5	2.50	123.9	61.0	2.40	28.5	92.2
SSMH-2.500-4.00-CAT50	63.5	2.50	123.9	101.6	4.00	28.5	92.2

Shell Mill Holders		Balanced to G6.3 @ 8,000 RPM					
Catalog Number	Dimensions						
	d (mm)	d (inch)	D (mm)	A (mm)	A (inch)	L ₁ (mm)	D ₁ (mm)
BT30							
SSMH-0.500-1.18-BT30	12.7	0.50	36.6	30.0	1.18	14.2	25.4
SSMH-0.750-1.18-BT30	19.1	0.75	44.5	30.0	1.18	17.5	28.7
SSMH-1.000-1.77-BT30	25.4	1.00	55.6	45.0	1.77	17.5	40.1
SSMH-16-40-BT30	16	-	38	40	-	17	-
SSMH-22-40-BT30	22	-	48	40	-	19	-
SSMH-27-40-BT30	27	-	58	40	-	21	-
BT40							
SSMH-0.500-4.00-BT40	12.7	0.50	36.6	101.6	4.00	14.2	25.4
SSMH-0.750-1.77-BT40	19.1	0.75	44.5	45.0	1.77	17.5	28.7
SSMH-0.750-4.00-BT40	19.1	0.75	44.5	101.6	4.00	17.5	28.7
SSMH-0.750-6.00-BT40	19.1	0.75	44.5	152.4	6.00	17.5	28.7
SSMH-1.000-1.77-BT40	25.4	1.00	55.6	45.0	1.77	17.5	40.1
SSMH-1.000-4.00-BT40	25.4	1.00	55.6	101.6	4.00	17.5	40.1
SSMH-1.000-6.00-BT40	25.4	1.00	55.6	152.4	6.00	17.5	40.1
SSMH-1.250-2.36-BT40	31.8	1.25	69.9	59.9	2.36	17.5	50.3
SSMH-1.250-5.00-BT40	31.8	1.25	69.9	127.0	5.00	17.5	50.3
SSMH-1.500-2.36-BT40	38.1	1.50	85.9	59.9	2.36	23.9	60.7
SSMH-1.500-5.00-BT40	38.1	1.50	85.9	127.0	5.00	23.9	60.7
SSMH-16-100-BT40	16	-	38	100	-	17	-
SSMH-16-40-BT40	16	-	38	40	-	17	-
SSMH-22-100-BT40	22	-	48	100	-	19	-
SSMH-22-160-BT40	22	-	48	160	-	19	-
SSMH-22-40-BT40	22	-	48	40	-	19	-
SSMH-27-100-BT40	27	-	58	100	-	21	-
SSMH-27-160-BT40	27	-	58	160	-	21	-
SSMH-27-40-BT40	27	-	58	40	-	21	-
SSMH-32-100-BT40	32	-	78	100	-	24	-
SSMH-32-50-BT40	32	-	78	50	-	24	-
SSMH-40-100-BT40	40	-	88	100	-	27	-
SSMH-40-50-BT40	40	-	88	50	-	27	-



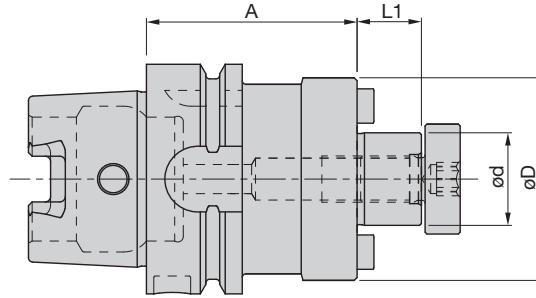

Shell Mill Holders		Balanced to G2.5 @ 15,000 RPM				
Catalog Number	Dimensions					
	d (mm)	d (inch)	D (mm)	A (mm)	A (inch)	L ₁ (mm)
HSK63						
SSMH-0.500-2.00-HSKA63	12.7	0.50	36.6	50.8	2.00	14.2
SSMH-0.750-2.00-HSKA63	19.1	0.75	44.5	50.8	2.00	17.5
SSMH-1.000-2.25-HSKA63	25.4	1.00	55.6	57.2	2.25	17.5
SSMH-1.250-2.25-HSKA63	31.8	1.25	69.9	57.2	2.25	17.5
SSMH-1.500-2.25-HSKA63	38.1	1.50	58.9	57.2	2.25	23.9
SSMH-16-100-HSKA63	16	-	38	100	3.94	17
SSMH-16-50-HSKA63	16	-	38	50	1.97	17
SSMH-22-100-HSKA63	22	-	48	100	3.94	19
SSMH-22-50-HSKA63	22	-	48	50	1.97	19
SSMH-27-100-HSKA63	27	-	58	100	3.94	21
SSMH-27-60-HSKA63	27	-	58	60	2.36	21
SSMH-32-100-HSKA63	32	-	78	100	3.94	24
SSMH-32-60-HSKA63	32	-	78	60	2.36	24
SSMH-40-100-HSKA63	40	-	88	100	3.94	27
SSMH-40-60-HSKA63	40	-	88	60	2.36	27

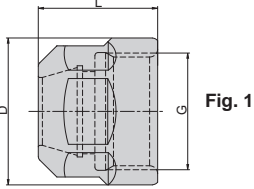
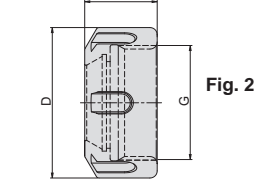

Clamping Nut – ER to DIN 6499 – Balanced

 	Catalog Number	Dimensions			Fig	
		Size	D	L		G
	ER16-DIN6499	1-10	28.0	17.5	M22x1.5	1
	ER20-DIN6499	1-13	34.0	19.0	M25x1.5	1
	ER25-DIN6499	2-16	42.0	20.0	M32x1.5	2
	ER32-DIN6499	2-20	50.0	22.5	M40x1.5	2
	ER40-DIN6499	3-26	63.0	25.5	M50x1.5	2

Clamping Nut – “Mini” ER

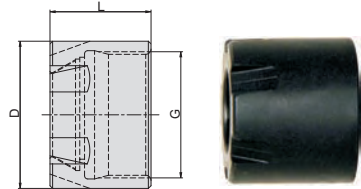
	Catalog Number	Dimensions			Fig	
		Size	D	L		G
	ER11M	1-7	16.0	11.3	M13x0.75	-
	ER16M	1-10	22.0	17.0	M19x1.0	-
	ER20M	1-13	28.0	19.0	M24x1.0	-
	ER25M	2-16	35.0	20.0	M30x1.0	-

Clamping Nut – ER for Sealing Discs

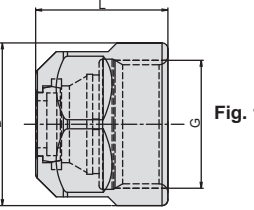
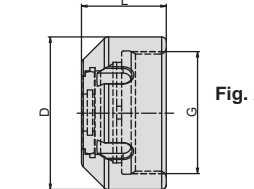
 	Catalog Number	Dimensions			Fig	
		Size	D	L		G
	ER16-IC	1-10	28.0	22.5	M22x1.5	1
	ER20-IC	1-13	34.0	24.0	M25x1.5	1
	ER25-IC	2-16	42.0	25.0	M32x1.5	2
	ER32-IC	2-20	50.0	27.5	M40x1.5	2
	ER40-IC	3-26	63.0	30.5	M50x1.5	2



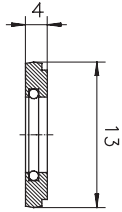

Fig SD ER 16

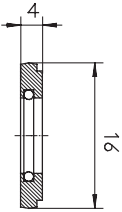

Fig SD ER 20

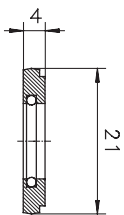

Fig SD ER 25

Sealing Discs for ER-IC Clamping Nuts

Catalog Number	Dimensions	
	Sealing Capacity (mm)	Sealing Capacity (inch)

Sealing Discs for ER16-IC Clamping Nuts (Inch & Metric)

SD-ER16-3.0-2.5mm	3.0-2.5	0.1181"-0.0984"
SD-ER16-3.5-3.0mm	3.5-3.0	0.1378"-0.1181"
SD-ER16-4.0-3.5mm	4.0-3.5	0.1575"-0.1378"
SD-ER16-4.5-4.0mm	4.5-4.0	0.1772"-0.1575"
SD-ER16-5.0-4.5mm	5.0-4.5	0.1969"-0.1772"
SD-ER16-5.5-5.0mm	5.5-5.0	0.2165"-0.1969"
SD-ER16-6.0-5.5mm	6.0-5.5	0.2362"-0.2160"
SD-ER16-6.5-6.0mm	6.5-6.0	0.2559"-0.2362"
SD-ER16-7.0-6.5mm	7.0-6.5	0.2756"-0.2559"
SD-ER16-7.5-7.0mm	7.5-7.0	0.2953"-0.2756"
SD-ER16-8.0-7.5mm	8.0-7.5	0.3150"-0.2953"
SD-ER16-8.5-8.0mm	8.5-8.0	0.3347"-0.3150"
SD-ER16-9.0-8.5mm	9.0-8.5	0.3543"-0.3347"
SD-ER16-9.5-9.0mm	9.5-9.0	0.3740"-0.3543"
SD-ER16-10.0-9.5mm	10.0-9.5	0.3937"-0.3740"

Sealing Discs for ER20-IC Clamping Nuts (Inch & Metric)

SD-ER20-3.0-2.5mm	3.0-2.5	0.1181"-0.0984"
SD-ER20-3.5-3.0mm	3.5-3.0	0.1378"-0.1181"
SD-ER20-4.0-3.5mm	4.0-3.5	0.1575"-0.1378"
SD-ER20-4.5-4.0mm	4.5-4.0	0.1772"-0.1575"
SD-ER20-5.0-4.5mm	5.0-4.5	0.1969"-0.1772"
SD-ER20-5.5-5.0mm	5.5-5.0	0.2165"-0.1969"
SD-ER20-6.0-5.5mm	6.0-5.5	0.2362"-0.2160"
SD-ER20-6.5-6.0mm	6.5-6.0	0.2559"-0.2362"
SD-ER20-7.0-6.5mm	7.0-6.5	0.2756"-0.2559"
SD-ER20-7.5-7.0mm	7.5-7.0	0.2953"-0.2756"
SD-ER20-8.0-7.5mm	8.0-7.5	0.3150"-0.2953"
SD-ER20-8.5-8.0mm	8.5-8.0	0.3347"-0.3150"
SD-ER20-9.0-8.5mm	9.0-8.5	0.3543"-0.3347"
SD-ER20-9.5-8.0mm	9.5-9.0	0.3740"-0.3543"
SD-ER20-10.0-9.5mm	10.0-9.5	0.3937"-0.3740"
SD-ER20-10.5-10mm	10.5-10.0	0.4134"-0.3937"
SD-ER20-11.0-10.5mm	11.0-10.5	0.4330"-0.4134"
SD-ER20-11.5-11.0mm	11.5-11.0	0.4528"-0.4330"
SD-ER20-12.0-11.5mm	12.0-11.5	0.4724"-0.4528"
SD-ER20-12.5-12.0mm	12.5-12.0	0.4921"-0.4724"
SD-ER20-13.0-12.5mm	13.0-12.5	0.5118"-0.4921"

Sealing Discs for ER25-IC Clamping Nuts (Inch & Metric)

SD-ER25-3.0-2.5mm	3.0-2.5	0.1181"-0.0984"
SD-ER25-3.5-3.0mm	3.5-3.0	0.1378"-0.1181"
SD-ER25-4.0-3.5mm	4.0-3.5	0.1575"-0.1378"
SD-ER25-4.5-4.0mm	4.5-4.0	0.1772"-0.1575"
SD-ER25-5.0-4.5mm	5.0-4.5	0.1969"-0.1772"
SD-ER25-5.5-5.0mm	5.5-5.0	0.2165"-0.1969"
SD-ER25-6.0-5.5mm	6.0-5.5	0.2362"-0.2160"
SD-ER25-6.5-6.0mm	6.5-6.0	0.2559"-0.2362"
SD-ER25-7.0-6.5mm	7.0-6.5	0.2756"-0.2559"
SD-ER25-7.5-7.0mm	7.5-7.0	0.2953"-0.2756"
SD-ER25-8.0-7.5mm	8.0-7.5	0.3150"-0.2953"
SD-ER25-8.5-8.0mm	8.5-8.0	0.3347"-0.3150"
SD-ER25-9.0-8.5mm	9.0-8.5	0.3543"-0.3347"
SD-ER25-9.5-9.0mm	9.5-9.0	0.3740"-0.3543"
SD-ER25-10.0-9.5mm	10.0-9.5	0.3937"-0.3740"
SD-ER25-10.5-10.0mm	10.5-10.0	0.4134"-0.3937"
SD-ER25-11.0-10.5mm	11.0-10.5	0.4330"-0.4134"
SD-ER25-11.5-11.0mm	11.5-11.0	0.4528"-0.4330"
SD-ER25-12.0-11.5mm	12.0-11.5	0.4724"-0.4528"
SD-ER25-12.5-12.0mm	12.5-12.0	0.4921"-0.4724"
SD-ER25-13.0-12.5mm	13.0-12.5	0.5118"-0.4921"
SD-ER25-13.5-13.0mm	13.5-13.0	0.5315"-0.5118"
SD-ER25-14.0-13.5mm	14.0-13.5	0.5512"-0.5315"
SD-ER25-14.5-14.0mm	14.5-14.0	0.5709"-0.5512"
SD-ER25-15.0-14.5mm	15.0-14.5	0.5905"-0.5709"
SD-ER25-15.5-15.0mm	15.5-15.0	0.6102"-0.5905"
SD-ER25-16.0-15.5mm	16.0-15.5	0.6300"-0.6102"



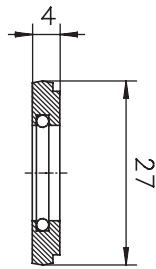

Fig
SD ER 32

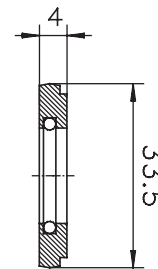

Fig
SD ER 40

Sealing Discs for ER-IC Clamping Nuts

Catalog Number	Dimensions	
	Sealing Capacity (mm)	Sealing Capacity (inch)
Sealing Discs for ER32-IC Clamping Nuts (Inch & Metric)		
SD-ER32-3.0-2.5mm	3.0-2.5	0.1181"-0.0984"
SD-ER32-3.5-3.0mm	3.5-3.0	0.1378"-0.1181"
SD-ER32-4.0-3.5mm	4.0-3.5	0.1575"-0.1378"
SD-ER32-4.5-4.0mm	4.5-4.0	0.1772"-0.1575"
SD-ER32-5.0-4.5mm	5.0-4.5	0.1969"-0.1772"
SD-ER32-5.5-5.0mm	5.5-5.0	0.2165"-0.1969"
SD-ER32-6.0-5.5mm	6.0-5.5	0.2362"-0.2160"
SD-ER32-6.5-6.0mm	6.5-6.0	0.2559"-0.2362"
SD-ER32-7.0-6.5mm	7.0-6.5	0.2756"-0.2559"
SD-ER32-7.5-7.0mm	7.5-7.0	0.2953"-0.2756"
SD-ER32-8.0-7.5mm	8.0-7.5	0.3150"-0.2953"
SD-ER32-8.5-8.0mm	8.5-8.0	0.3347"-0.3150"
SD-ER32-9.0-8.5mm	9.0-8.5	0.3543"-0.3347"
SD-ER32-9.5-9.0mm	9.5-9.0	0.3740"-0.3543"
SD-ER32-10.0-9.5mm	10.0-9.5	0.3937"-0.3740"
SD-ER32-10.5-10.0mm	10.5-10.0	0.4134"-0.3937"
SD-ER32-11.0-10.5mm	11.0-10.5	0.4330"-0.4134"
SD-ER32-11.5-11.0mm	11.5-11.0	0.4528"-0.4330"
SD-ER32-12.0-11.5mm	12.0-11.5	0.4724"-0.4528"
SD-ER32-12.5-12.0mm	12.5-12.0	0.4921"-0.4724"
SD-ER32-13.0-12.5mm	13.0-12.5	0.5118"-0.4921"
SD-ER32-13.5-13.0mm	13.5-13.0	0.5315"-0.5118"
SD-ER32-14.0-13.5mm	14.0-13.5	0.5512"-0.5315"
SD-ER32-14.5-14.0mm	14.5-14.0	0.5709"-0.5512"
SD-ER32-15.0-14.5mm	15.0-14.5	0.5905"-0.5709"
SD-ER32-15.5-15.0mm	15.5-15.0	0.6102"-0.5905"
SD-ER32-16.0-15.5mm	16.0-15.5	0.6300"-0.6102"
SD-ER32-16.5-16.0mm	16.5-16.0	0.6496"-0.6300"
SD-ER32-17.0-16.5mm	17.0-16.5	0.6693"-0.6496"
SD-ER32-19.0-18.5mm	19.0-18.5	0.7480"-0.7284"
SD-ER32-19.5-19.0mm	19.5-19.0	0.7677"-0.7480"
SD-ER32-20.0-19.5mm	20.0-19.5	0.7874"-0.7677"

Sealing Discs for ER-IC Clamping Nuts

Catalog Number	Dimensions	
	Sealing Capacity (mm)	Sealing Capacity (inch)
Sealing Discs for ER40-IC Clamping Nuts (Inch & Metric)		
SD-ER40-3.0-2.5mm	3.0-2.5	0.1181"-0.0984"
SD-ER40-3.5-3.0mm	3.5-3.0	0.1378"-0.1181"
SD-ER40-4.0-3.5mm	4.0-3.5	0.1575"-0.1378"
SD-ER40-4.5-4.0mm	4.5-4.0	0.1772"-0.1575"
SD-ER40-5.0-4.5mm	5.0-4.5	0.1969"-0.1772"
SD-ER40-5.5-5.0mm	5.5-5.0	0.2165"-0.1969"
SD-ER40-6.0-5.5mm	6.0-5.5	0.2362"-0.2160"
SD-ER40-6.5-6.0mm	6.5-6.0	0.2559"-0.2362"
SD-ER40-7.0-6.5mm	7.0-6.5	0.2756"-0.2559"
SD-ER40-7.5-7.0mm	7.5-7.0	0.2953"-0.2756"
SD-ER40-8.0-7.5mm	8.0-7.5	0.3150"-0.2953"
SD-ER40-8.5-8.0mm	8.5-8.0	0.3347"-0.3150"
SD-ER40-9.0-8.5mm	9.0-8.5	0.3543"-0.3347"
SD-ER40-9.5-9.0mm	9.5-9.0	0.3740"-0.3543"
SD-ER40-10.0-9.5mm	10.0-9.5	0.3937"-0.3740"
SD-ER40-10.5-10.0mm	10.5-10.0	0.4134"-0.3937"
SD-ER40-11.0-10.5mm	11.0-10.5	0.4330"-0.4134"
SD-ER40-11.5-11.0mm	11.5-11.0	0.4528"-0.4330"
SD-ER40-12.0-11.5mm	12.0-11.5	0.4724"-0.4528"
SD-ER40-12.5-12.0mm	12.5-12.0	0.4921"-0.4724"
SD-ER40-13.0-12.5mm	13.0-12.5	0.5118"-0.4921"
SD-ER40-13.5-13.0mm	13.5-13.0	0.5315"-0.5118"
SD-ER40-14.0-13.5mm	14.0-13.5	0.5512"-0.5315"
SD-ER40-14.5-14.0mm	14.5-14.0	0.5709"-0.5512"
SD-ER40-15.0-14.5mm	15.0-14.5	0.5905"-0.5709"
SD-ER40-15.5-15.0mm	15.5-15.0	0.6102"-0.5905"
SD-ER40-16.0-15.5mm	16.0-15.5	0.6300"-0.6102"
SD-ER40-16.5-16.0mm	16.5-16.0	0.6496"-0.6300"
SD-ER40-17.0-16.5mm	17.0-16.5	0.6693"-0.6496"
SD-ER40-17.5-17.0mm	17.5-17.0	0.6890"-0.6693"
SD-ER40-18.0-17.5mm	18.0-17.5	0.7087"-0.6890"
SD-ER40-18.5-18.0mm	18.5-18.0	0.7284"-0.7087"
SD-ER40-19.0-18.5mm	19.0-18.5	0.7480"-0.7284"
SD-ER40-19.5-19.0mm	19.5-19.0	0.7677"-0.7480"
SD-ER40-20.0-19.5mm	20.0-19.5	0.7874"-0.7677"
SD-ER40-20.5-20.0mm	20.5-20.0	0.8070"-0.7874"
SD-ER40-21.0-20.5mm	21.0-20.5	0.8267"-0.8070"
SD-ER40-21.5-21.0mm	21.5-21.0	0.8464"-0.8267"
SD-ER40-22.0-21.5mm	22.0-21.5	0.8661"-0.8464"
SD-ER40-22.5-22.0mm	22.5-22.0	0.8857"-0.8661"
SD-ER40-23.0-22.5mm	23.0-22.5	0.9055"-0.8857"
SD-ER40-23.5-23.0mm	23.5-23.0	0.9251"-0.9055"
SD-ER40-24.0-23.5mm	24.0-23.5	0.9448"-0.9251"
SD-ER40-24.5-24.0mm	24.5-24.0	0.9645"-0.9448"
SD-ER40-25.0-24.5mm	25.0-24.5	0.9842"-0.9645"
SD-ER40-25.5-25.0mm	25.5-25.0	1.0039"-0.9842"
SD-ER40-26.0-25.5mm	26.0-25.5	1.0236"-1.0039"

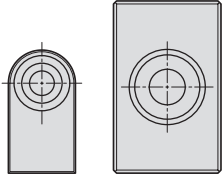

Drive Key for Inch Shell Mill Holders

	Catalog Number	For Size (inch)
	SM64750	0.500"
	SM64751	0.750"
	SM64752	1.000"
	SM64753	1.250"
	SM64754	1.500"
	SM64755	2.000"
	SM64756	2.500"

Locking Screw for Inch Shell Mill Holders

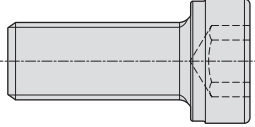
	Catalog Number	For Size (inch)
	SM64830	0.500"
	SM64831	0.750"
	SM64832	1.000"
	SM64833	1.250"
	SM64834	1.500"
	SM64835	2.000"
	SM64836	2.500"

Drive Key for Metric Shell Mill Holders

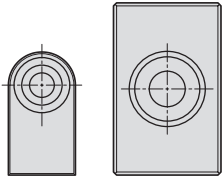
	Catalog Number	For Size (mm)
	SM16-8x8x14	16
	SM22-10x10x17	22
	SM27-12x14x20	27
	SM32-14x14x22	32
	SM40-15.9x16x21	40
	SM60-25.4x25x31	60

Locking Screw for Metric Shell Mill Holders Drive Keys

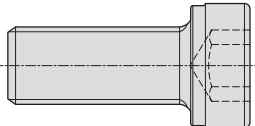
	Catalog Number	For Size (mm)
	M 3 x 8-DIN 912	16
	M 4 X 8-DIN 912	22
	M 4 X 14-DIN 912	27
	M 5 X 13-DIN 912	32
	M 6 X 16-DIN 912	40
	M 12 X 25-DIN 912	60

Locking Screw for Metric Shell Mill Holders (Small Counterbore)

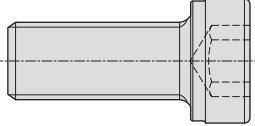
	Catalog Number	For Size (mm)
	M 8 x 20 DIN 912	16
	M 10 x 30 DIN 912	22
	M 12 x 35 DIN 912	27
	M 16 x 40 DIN 912	32

Locking Screw for Metric Shell Mill Holders (Large Counterbore)

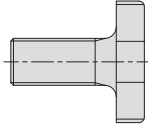

Catalog Number	For Size (mm)
M 8 x 16-DIN 6367	16
M 10 x 22-DIN 6367	22
M 12 x 27-DIN 6367	27
M 16 x 32-DIN 6367	32
M 20 x 40-DIN 6367	40

Locking Screw for End Mill Holders

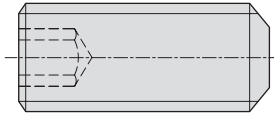

Catalog Number	For Size (inch)
6-32UNSC8	0.125"
8-32UNSC7	0.187"
1/4-28UNF-8	0.250"
5/16-24UNF-10	0.312"
3/8-24UNF-9	0.375"
7/16-20UNF-13	0.437"
7/16-20UNF-12	0.500"
1/2-20UNF-14	0.625"
5/8-18UNF-14	0.750" & 0.875"
3/4-16UNF-14	1.000"
3/4-16UNF-16	1.250" & 1.500"
1-14UNS-23	2.000"

Adjusting Screw Threaded Stud DIN 913 for End Mill Holders

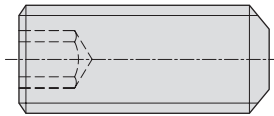

Catalog Number	For Size
M5x5 DIN913	CAT40/50
M5x6 DIN913	BT40
M6x10 DIN913	BT50

Adjusting Screw for ER Collet Chuck Holders

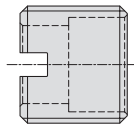

Catalog Number	For Size
M10 x 15-001	ER16
M12 x 15-001	ER20
M16 x 15-001	ER25
M22 x 1.5 x 15-001	ER32 & 40

Coolant Tube for HSK Holders

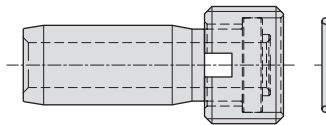

Catalog Number	For Size
CTHSK 32-10	HSK 32
CTHSK 40-12	HSK 40
CTHSK 50-16	HSK 50
CTHSK 63-18	HSK 63
CTHSK 80-20	HSK 80
CTHSK 100-24	HSK 100

Wrenches for Milling Chucks

	Catalog Number	Size (metric & inch)
	SC-20	20 & 0.75"
	SC-25	25 & 1.000"
	SC-32	32 & 1.250"
	SC-1.5"	1.5"
	SC-2.0"	2.0"

Wrenches for ER Collect Holders

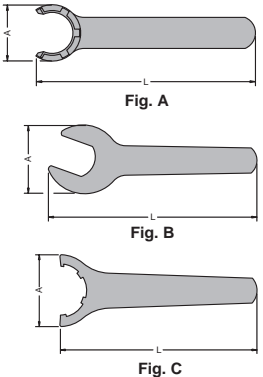
	Catalog Number	For Clamping Nut	Dimensions			Fig
	S-E11M	E11M	A	L	G	A
	S-E16M	E16M	22.5	110.0	-	A
	S-E20M	E20M	29.0	120.0	-	A
	S-E25M	E25M	36.0	130.0	-	A
	S-GS-SW25	ER16-DIN6499	42.0	140.0	-	B
	S-E20	ER20-DIN6499	54.0	168.0	-	B
	S-E25	ER25-DIN6499	65.0	210.0	-	C
	S-E32	ER32-DIN6499	75.0	250.0	-	C
	S-E40	ER40-DIN6499	90.0	290.0	-	C

Wrench for Shell Mill Holders Inch Locking Screws

	Catalog Number	For Size (inch)
	SM 3/16" hex key	0.500
	SM 1/4" hex key	0.750
	SM 5/16" hex key	1.000 & 1.250
	SM 3/8" hex key	1.500
	SM 1/2" hex key	2.000 & 2.500

Wrench for Shell Mill Holders Metric Locking Screws (Small Counterbore)

	Catalog Number	For Size (mm)
	SM6 hex key	16
	SM8 hex key	22
	SM10 hex key	27
	SM14 hex key	32
	SM17 hex key	40

Wrench for Shell Mill Holders Metric Locking Screws (Large Counterbore)

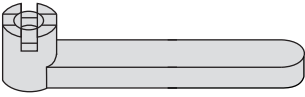
	Catalog Number	For Size (mm)
	SM-16 DIN 6368	16
	SM-22 DIN 6368	22
	SM-27 DIN 6368	27
	SM-32 DIN 6368	32
	SM-40 DIN 6368	40

Wrench for HSK Coolant Tubes

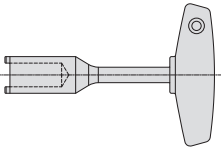
	Catalog Number	For Size
	S-HSK 32-8.5x115	HSK 32
	S-HSK 40-10.5x115	HSK 40
	S-HSK 50-14.5x115	HSK 50
	S-HSK 63-16.5x136	HSK 63
	S-HSK 80-18.5x136	HSK 80
	S-HSK 100-22x136	HSK 100



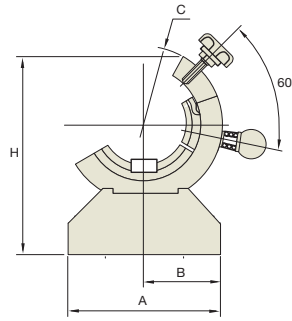

Tool Clamp

- No surface damage such as abrasion and scratch around taper shank closely associated with tool runout
- Easy to assemble and disassemble pull stud bolt
- Convenient and safe when using coolant tube wrench with milling chuck or ER collet chuck

Taper No.	Catalog Number	Dimensions (mm)				Weight (kg)
		A	B	C	H	
BT30	STCP30	125	65	108	135	3.0
BT40	STCP40	160	80	138	180	7.6
BT50	STCP50	180	90	165	205	8.6
SK30	STSK30	125	65	108	135	3.0
SK40	STSK40	160	80	138	180	7.6
SK50	STSK50	180	90	165	205	8.6

Retention Knobs



Catalog Number	Machine Taper	Common Machines
SRKC50-STD	C50	HURCO W/COOLANT
SRKC40-MZC	C40	MAZAK W/COOLANT
SRKC40S-4500	C40	HAAS
SRKC40-STD	C40	FADAL W/COOLANT
SRKC50-4500H	C50	OKK W/COOLANT
SRKC40-1500-ISO	C40	DAEWOO
SRKC40S-4500	C40	HAAS W/COOLANT
SRKC40-1500H	C40	MAKINO W/COOLANT
SRKC50-4500	C50	OKK
SRKC40-STD	C40	FADAL
SRKC40S-9000	C40	MORI-SEKI
SRKC40-4500	C40	OKUMA
SRKC50-MZ	C50	MAZAK W/ O-RING
SRKC50-STD	C50	MAZAK
SRKC50-TOY	C50	TOYOTA W/O-RING



Spindle Cleaners – Professional Series



These easy to use wipers clean your spindles assuring that toolholder tapers make continuous positive contact for repeatable on-center performance. The wiper can also be used for cleaning the bores of collet chucks and Morse Taper holders.

Catalog Number	Description
ISO30	30-Taper Spindle Clean equipped with cleaning blades
ISO40	40-Taper Spindle Clean equipped with cleaning blades
ISO50	50-Taper Spindle Clean equipped with cleaning blades

Taper Cleaners for HSK Tool Tapers

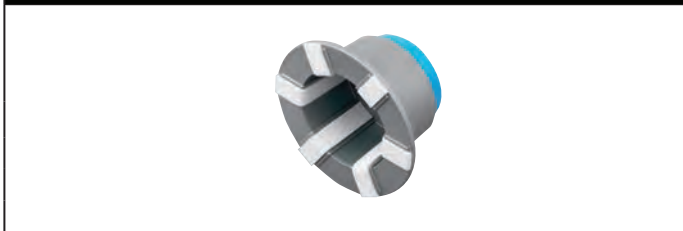

For cleaning HSK tool tapers. Plastic body with leather inserts.	For cleaning HSK tool tapers. Plastic body with leather inserts.
Catalog Number	HSK Form A/C/E
76.208.040	40
76.208.050	50
76.208.063	63

Taper Cleaners for HSK Spindles

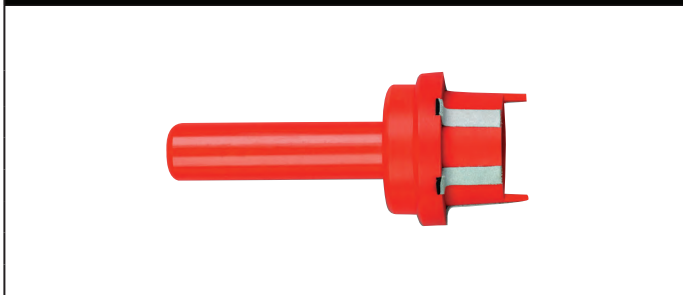

For cleaning HSK spindle tapers. Plastic body with leather inserts.	
Catalog Number	HSK Form A/C
76.205.032	32
76.205.040	40
76.205.050	50
76.205.063	63
76.205.080	80
76.205.100	100

Taper Cleaners for 7/24 Spindle Tapers (Steep Taper)

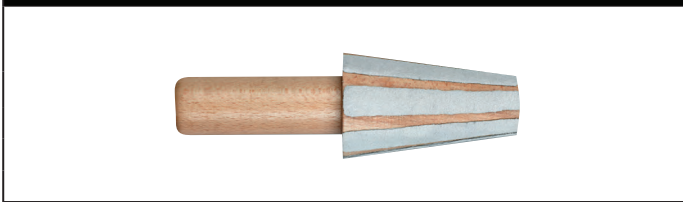

For cleaning 7/24 (Steep Taper) spindle tapers. Plastic body with leather inserts.	
Catalog Number	CAT Size
76.200.030	30
76.200.040	40
76.200.050	50





SUMITOMO

CARBIDE - CBN - DIAMOND

1-800-950-5202

www.sumicarbide.com

TECHNICAL INFORMATION & HARDWARE

Pages 565-620



Technical
Information

TECHNICAL INFORMATION	PAGES
Turning Hardware.....	566-568
Basics of Turning.....	569
Basics of Threading.....	571
Tool Failure/Tool Life.....	571
Troubleshooting for Turning.....	572
Chip Control.....	573
PCBN Grades.....	574-581
PCD Grades.....	582-583
Laydown Threading Applications.....	584-585
Recommended Running Conditions.....	586-597
Tool Life/Failure.....	598-599
Basics of Milling.....	600
Milling Inserts.....	601-608
Milling Cutters.....	609
General Milling Practices.....	610
Lead Angle Effect.....	611
Radial Chip Thinning.....	612
Milling Speeds & Feeds.....	613-615
Drilling Conversion/Tap Chart.....	616
Drill Guidance.....	617-620

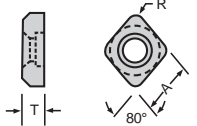
80° Diamond Shims	Sumitomo	A	T	R
	Cat. No.	Insert I.C.		
	ICSN322	.500	.1875	.031
	ICSN433	.500	.1875	.047
	ICSN533	.625	.1875	.047
	ICSN633	.750	.1875	.047

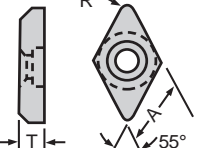
55° Diamond Shims	Sumitomo	A	T	R
	Cat. No.	Insert I.C.		
	IDSN322	.375	.125	.031
	IDSN433	.500	.1875	.047
	IDSN443	.500	.250	.047
	IDSN533	.625	.1875	.047

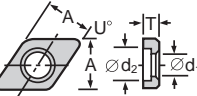
55° Diamond Shim	Sumitomo	Size (mm)					
	Cat. No.	A	T	d ₁	d ₂	-	0°
	SDW423	12.65	3.18	6.2	8.0	-	55

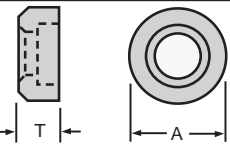
Round Shims			
			
Sumitomo	A	T	R
Cat. No.	Insert I.C.		
IRSN43	.500	.1875	-
IRSN44	.500	.250	-

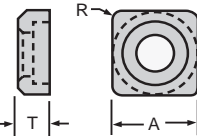
Square Shims	Sumitomo	A	T	R
	Cat. No.	Insert I.C.		
	ISSN433	.500	.1875	.047
	ISSN443	.500	.250	.047
	ISSN533	.625	.1875	.047
	ISSN543	.625	.250	.047
	ISSN633	.750	.1875	.047
	ISSN643	.750	.250	.047

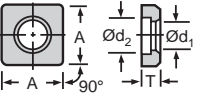
Square Shims	Sumitomo	Size (mm)					
	Cat. No.	A	T	d ₁	d ₂	-	-
	SSW423	12.65	3.18	6.2	8	-	-
	SSW433	12.65	4.76	6.2	8	-	-
	SSW534	15.85	4.76	7.8	9.7	-	-
	SSW635	19	4.76	9	11.5	-	-

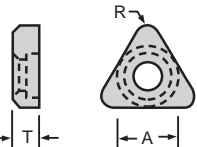
Triangle Shims	Sumitomo	A	T	R
	Cat. No.	Insert I.C.		
	ITSN323	.375	.125	.047
	ITSN333	.375	.1875	.047
	ITSN423	.500	.125	.047
	ITSN432	.500	.1875	.031
	ITSN433	.500	.1875	.047
	ITSN534	.625	.1875	.0625

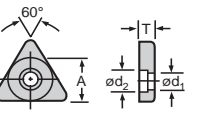
Triangle Shims	Sumitomo	Size (mm)					
	Cat. No.	A	T	d ₁	d ₂	-	-
	STW323	9.5	3.18	4.7	6.5	-	-
	STW333	9.5	4.76	4.7	6.5	-	-
	STW434	12.65	4.76	6.2	8	-	-
	STW534	15.85	4.76	7.8	9.7	-	-

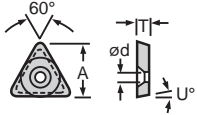
Triangle Shims	Sumitomo	Size (mm)					
	Cat. No.	A	T	d ₁	d ₂	-	u°
	STPD322	8.4	3.18	3.4	-	-	6
	STPD422	11.0	3.18	3.4	-	-	6

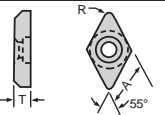
35° Diamond Shims			
			
Sumitomo	A	T	R
Cat. No.	Insert I.C.		
IVSN322	.375	.125	.031
IVSN432	.500	.1875	.031
IVSN433	.500	.1875	.047

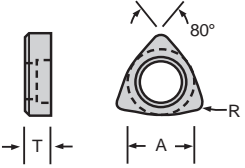
Trigon Shims			
			
Sumitomo	A	T	R
Cat. No.	Insert I.C.		
IWSN322	.375	.125	.031
IWSN433	.500	.1875	.1875

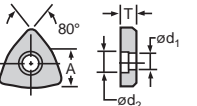
Trigon Shim	Sumitomo	Size (mm)					
	Cat. No.	A	T	d ₁	d ₂	-	-
	SWW433	12.65	4.76	6.2	8	-	-
	SWW544	15.85	5.15	7.8	9.7	-	-

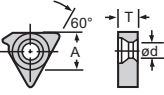
Threading Shim	Sumitomo	Size (mm)					
	Cat. No.	A	T	d	-	-	-
	LSTE31-0	9.5	2.7	5.2	-	-	-

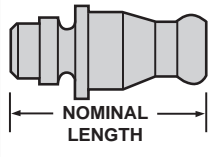

Lock Pins Negative Rake (Top & Bottom Lock)	Sumitomo	Insert	Nominal	Hex	Use With
	Cat. No.	I.C.	Length	Wrench	Seat
	BWP-46	.500	.578	.094	Yes
	NL-23	.250	.328	.0625	No
	NL-33	.375	.344	.078	No
	NL-33L	.375	.406	.078	No
	NL-34	.375	.453	.078	Yes
	NL-34L	.375	.516	.078	Yes
	NL-44	.500	.516	.094	No
	NL-46	.500	.672	.094	Yes
	NL-46L	.500	.734	.094	Yes
	NL-58	.625	.859	.125	Yes
NL-68	.750	.859	.141	Yes	

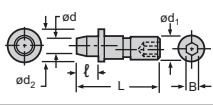
Cam Pin	Sumitomo Cat. No.	Size (mm)					
		d	d ₁	d ₂	L	ℓ	B
	CPB33	3.4	4.1	5.5	17	3.4	2.5
	CPB43	4.5	5.5	7	19	5	3
	CPB43S	4.5	5.5	7	16	5	3
	CPB44T	4.5	5.5	7	22	5	3

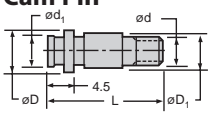
Cam Pin	Sumitomo Cat. No.	Size (mm)					
		d	Pitch	L	D	D ₁	d ₁
	MP416	M5	0.8	14	7.5	6	5
	MP420	M5	0.8	20	7.5	6	5
	MP531	M6	1.0	19.7	9.5	7	6.26
	MP534	M6	1.0	26.1	9.5	7	6.76

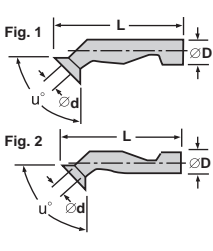
Clamp Stud	Sumitomo Cat. No.	Size (mm)				
		d	D	L	u°	Shape
	SR104B	3	3.4	21	60	Fig. 1
	SW43B	4	4.9	27.5	90	Fig. 2
	SW42L	4	4.9	22	90	Fig. 2
	SW43	4	4.9	27.5	90	Fig. 2
	SW53L	4.8	5.9	28.3	90	Fig. 2
	SW53R	4.8	5.9	28.3	90	Fig. 2
	SW54	4.8	5.9	35.5	90	Fig. 2
	SW54B	4.8	5.9	35.5	90	Fig. 2
	SW64L	5.5	6.9	33.8	90	Fig. 2
	SW64R	5.5	6.9	33.8	90	Fig. 2
	SW65	5.5	6.9	44.5	90	Fig. 2
	SW65B	5.5	6.9	44.5	90	Fig. 2

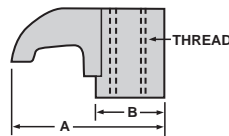
Finger Clamp			
	Sumitomo Cat. No.	A	Thread
CL19	.550	10-32	.310
CL6	.580	10-32	.310
CL7	.640	10-32	.310
CL20	.730	1/4-28	.375
CL9	.750	5/16-24	.430
CL12	.880	5/16-24	.430
CL30	1.000	5/16-24	.430

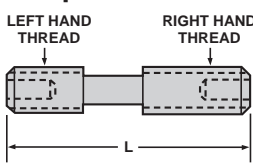
Differential Clamp Screws	Inch			
	Catalog Number	Thread	L	Wrench Size
	XNS35	10-32	.59	3/32
	XNS36	10-32	.75	3/32
	XNS47	1/4-28	.81	1/8
	XNS48	1/4-28	1.00	1/8
	XNS58	5/16-24	1.00	5/32
	XNS59	5/16-24	1.125	5/32
	XNS510	5/16-24	1.25	5/32

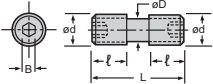
Differential Clamp Screw	Sumitomo Cat. No.	Size (mm)					
		d	pitch	L	ℓ	D	B
	WB613	M6	1.0	13	5	4.5	3
	WB616	M6	1.0	16	6	4.5	3
	WB820	M8	1.25	22	8.5	6.2	T27
	WB8F20	M8	1.0	20	8.5	6.2	4
	WB8F30	M8	1.0	3.0	11.5	6.2	4



Torx Insert Screws	Sumitomo Cat. No.	Size (mm)					
		d	Pitch	L	D	B	α°
	BFTX0204	M2	0.4	4.3	2.7	T6	60
	BFTX0204A	M2	0.4	4.3	2.7	T6	90
	BFTX02205	M2.2	0.45	4.5	3	T6	60
	BFTX02506N	M2.5	0.45	5.5	3.45	T8	60
	BFTX02507	M2.5	0.45	6.5	3.45	T8	60
	BFTX0305A	M3	0.5	5.3	4.3	T10	90
	BFTX0306A	M3	0.5	5.8	4.3	T10	90
	BFTX0307A	M3	0.5	6.8	4.3	T10	90
	BFTX03508	M3.5	0.6	8	5.1	T10	52
	BFTX0407A	M4	0.7	7.3	5.6	T15	90
	BFTX0409N	M4	0.7	9	5.6	T15	60
	BFTX0410A	M4	0.7	10.3	5.6	T15	90
	BFTX0509A	M5	0.8	9.3	6.9	T20	90

Torx Insert Screws	Sumitomo Cat. No.	D	T	L	B
			ST21.5	.130	M2.5x.45
	ST32.5	.213	M4x.7	.315	T-15

Shim Screws	Sumitomo Cat. No.	Insert I.C.	Size (mm)			
			D	L	H	T
	S34	.375	.24	.31	.078	10-32
	S46	.500	.30	.50	.094	1/4-28
	S58	.625	.40	.62	.125	5/16-24
	S68	.750	.46	.62	.140	3/8-24

Torx Wrench	Sumitomo Cat. No.	Size (mm)			
		B	C	b ₁	b ₂
	TRX06	T6	34.5	15	15
	TRX08	T8	34.5	19	19
	TRX10	T10	42.5	22	22
	TRX15	T15	45	22	27
	TRX20	T20	49.0	22	30

Flat Button Head Screw	Sumitomo Cat. No.	Size (mm)					
		d	Pitch	L	D	B	α°
	BHF0203T	M2	0.4	4	3	1.5	90
	BHF0203B	M2	0.4	5.5	3.5	1.5	90
	BHF0306R	M3	0.5	6.5	4.4	2	90
	BHF0308R	M3	0.5	8	4.4	2	90

Hex Low Head Cap Screw	Sumitomo Cat. No.	Size (mm)					
		d	Pitch	L	ℓ	D	B
	BHA0625	M6	1.0	30	11.3	10.5	4
	BHA0834	M8	1.25	34.2	12.7	12	5

Cap Screw	Sumitomo Cat. No.	Size (mm)					
		d	Pitch	L	ℓ	D	B
	BX0414	M4	0.7	14	Full	7	3
	BX0512	M5	0.8	12	Full	8.5	4
	BX0615	M6	1.0	15	Full	10	5
	BX0618	M6	1.0	18	18	10	5
	BX0622	M6	1.0	22	18	10	5

Set Screw	Sumitomo Cat. No.	Size (mm)					
		d	Pitch	L	ℓ	D	B
	BTD0520	M5	0.8	10	3	3.5	2.5
	BTD0607	M6	1.0	9	2	4	3
	BTD0609	M6	1.0	9	2	4	3
	BTD0615	M6	1.0	15	5	4	3
	BTD0812	M8	1.25	12	2	5	4
	BTD0820	M8	1.25	20	6	5	4
	BTD0825	M8	1.25	25	8.5	5	4

Nut	Sumitomo Cat. No.	Size (mm)					
		L	-	-	-	-	-
	BNBW2	2	-	-	-	-	-
	BNBW4	5	-	-	-	-	-
	BNBW7	8	-	-	-	-	-

Nut	Sumitomo Cat. No.	Size (mm)					
		d	L	D	B	-	-
	CPM43N	M5	8.5	7	3	-	-
	CPM43S	M5	6	7	3	-	-
	CPM54N	M6	9	9	4	-	-



Calculating Power Requirement

$$P_c = \frac{v_c \times f \times a_p \times k_c}{60 \times 10^3 \times \eta}$$

$$H = \frac{P_c}{0.75}$$

P_c : Net power requirement (KW)
 v_c : Cutting speed (m/min)
 f : Feed rate (mm/rev)
 a_p : Depth of cut (mm)
 k_c : Specific cutting force (MPa)
 H : Required horsepower (HP)
 η : Machine efficiency (0.70 to 0.85)

D Rough Value of Kc

Aluminium: 800MPa
 General Steel: 2,500 to 3,000MPa
 Cast Iron: 1,500MPa

Cutting Force

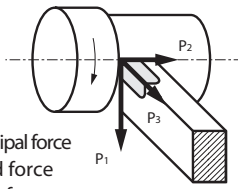

P_1 : Principal force
 P_2 : Feed force
 P_3 : Back force

D Calculating Cutting Force

$$P = \frac{K_c \times q}{1,000}$$

P : Cutting force (kN)
 K_c : Specific cutting force (MPa)
 q : Chip area (mm²)

n Relation Between Cutting Speed and Cutting Force

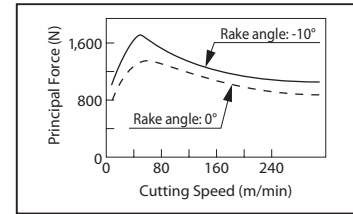

Relation Between Rake Angle and Cutting Force

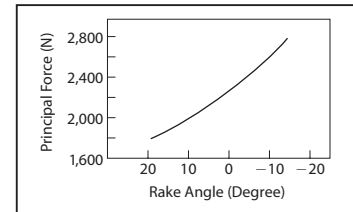

Calculating Cutting Speed

(1) Calculating rotation speed from cutting speed

$$n = \frac{1,000 \times v_c}{\pi \times D_m}$$

n : Spindle speed (min⁻¹)
 v_c : Cutting speed (m/min)
 D_m : Diameter of work piece (mm)
 π : ≈ 3.14

(Ex.) $v_c=150$ m/min, $D_m=100$ mm

$$n = \frac{1,000 \times 150}{3.14 \times 100} = 478 \text{ (min}^{-1}\text{)}$$

(2) Calculating cutting speed from rotational speed

$$v_c = \frac{\pi \times D_m \times n}{1,000}$$

Refer to the above table

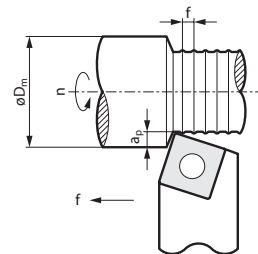

- n : Spindle speed (min⁻¹)
- v_c : Cutting speed (m/min)
- f : Feed rate (mm/rev)
- a_p : Depth of cut (mm)
- D_m : Diameter of work piece (mm)

Relation Between Feed Rate and Specific Cutting Force (For Carbon Steel)

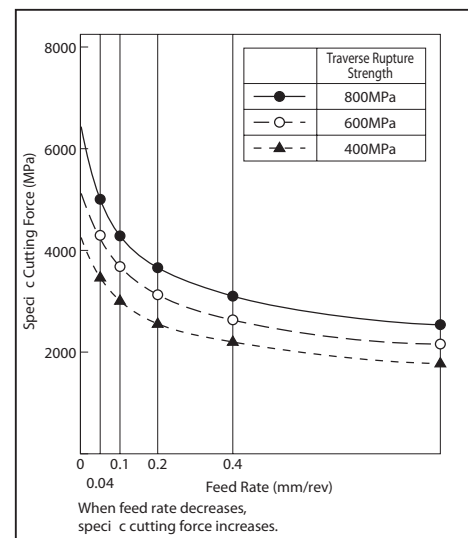

Theoretical Surface Finish

$$h = \frac{f^2}{8 \times r_e} \times 10^3$$

h : Theoretical surface roughness (μm)
 f : Feed rate (mm/rev)
 r_e : Nose radius (mm)

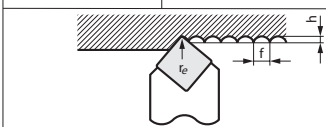

Actual Surface Roughness

Steel:
 Theoretical surface finish x 1.5 to 3
 Cast iron:
 Theoretical surface finish x 3 to 5

Ways to Improve Surface Finish

- (1) Use an insert with a larger nose radius.
- (2) Optimise the cutting speed and feed rate so that built-up edge does not occur.
- (3) Select an appropriate insert grade.
- (4) Use wiper insert

Relation Between Nose Radius and Cutting Force

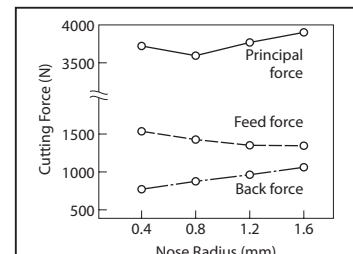

Work : SCM440(38HS)
 Inserts : TNGA2204 SS
 Holder : PTG NR2525-43
 Cutting Conditions : $v_c=100$ m/min
 $a_p=4$ mm
 $f=0.45$ mm/rev

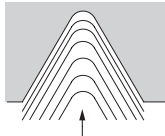
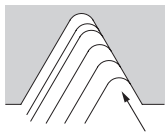
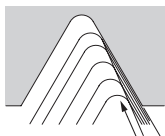
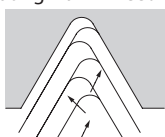

Threading

Machining Method	Characteristics
Radian Infeed 	<ul style="list-style-type: none"> · Most common threading technique, used mainly for small pitch threads. · Easy to change cutting conditions such as depth of cut, etc. · Wears evenly due to equal cut edge on right and left sides, which also translates into a long contact point and thus a tendency to chatter. · Difficult to control chip evacuation.
Flank Infeed 	<ul style="list-style-type: none"> · Effective for large pitch threads and blemish-prone work material surfaces. · Chips evacuate from one side for good chip control. · Heavy flank wear on right side.
Corrected Flank Infeed 	<ul style="list-style-type: none"> · Effective for large pitch threads and blemish-prone work material surfaces. · Chips evacuate from one side for good chip control. · Reduces flank wear on right side.
Alternating Flank Infeed 	<ul style="list-style-type: none"> · Effective for large pitch threads and blemish-prone work material surfaces. · Wears evenly on right and left cut edges. · Tendency for chip clogging due to alternating left and right flow.

Troubleshooting for Threading

	Failure	Cause	Countermeasures
Cutting Edge Failure	Excessive Cutting Edge Wear	· Tool material	· Select a more wear-resistant grade
		· Cutting condition	· Decrease the cutting speed · Optimise coolant flow · Review number of passes
	Uneven Wear on Right and Left Sides	· Insert attachment	· Optimise lead angle · Attach insert correctly
		· Cutting condition	· Change to alternating flank infeed
	Cutting Edge Chipping	· Cutting condition	· If caused by a built-up edge, increase cutting speed
Cutting Edge Fracture	· Packing of chips	· Check coolant supply (excessive coolant to cutting edge)	
	· Insert attachment	· Check insert and/or work material clamping method	
Shape, Poor Accuracy	Poor Surface Roughness	· Cutting condition	· Increase cutting speed
		· Tool material (wear)	· Select a more wear-resistant grade
		· Incorrect lead angle	· Optimise lead angle
Poor Thread Shape	· Insert attachment	· Inspect insert attachment	
	· Thread depth small	· Check cutting depth	

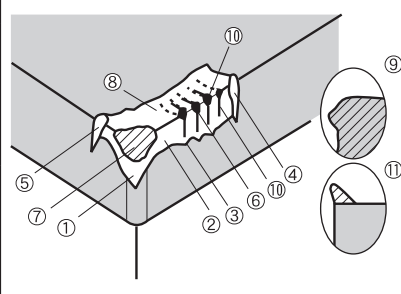

Forms of Tool Failures

	Cat.	No.	Name of Failure	Cause of Failure
	Resulting from Mechanical Causes	(1) to (5)		Flank Wear
(6)			Chipping	Fine breakages caused by high cutting loads or chattering.
(7)			Fracture	Due to the impact of an excessive mechanical force acting on the cutting edge.
Resulting from Chemical Reactions	(8)		Crater Wear	Swift chips removing tool material as it flow over the top face at high temperatures.
	(9)		Plastic Deformation	Cutting edge is depressed due to softening at high temperatures.
	(10)		Thermal Crack	Fatigue from rapid, repeated heating and cooling cycles during machining.
	(11)		Built-up Edge	Work material is pressure welded on the top face of the cutting edge.

Tool Wear

Forms of Tool Wear

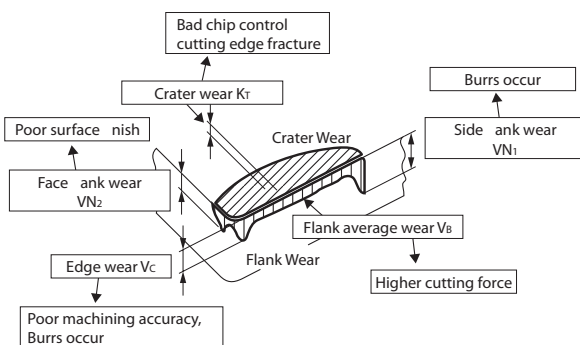

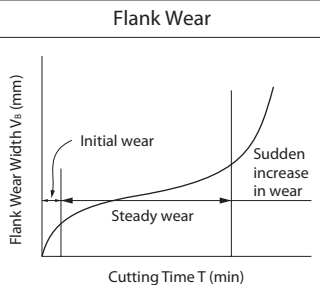
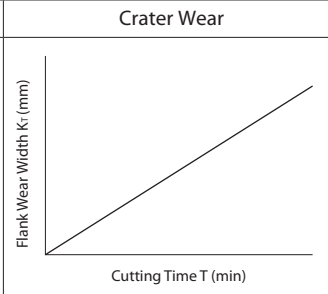

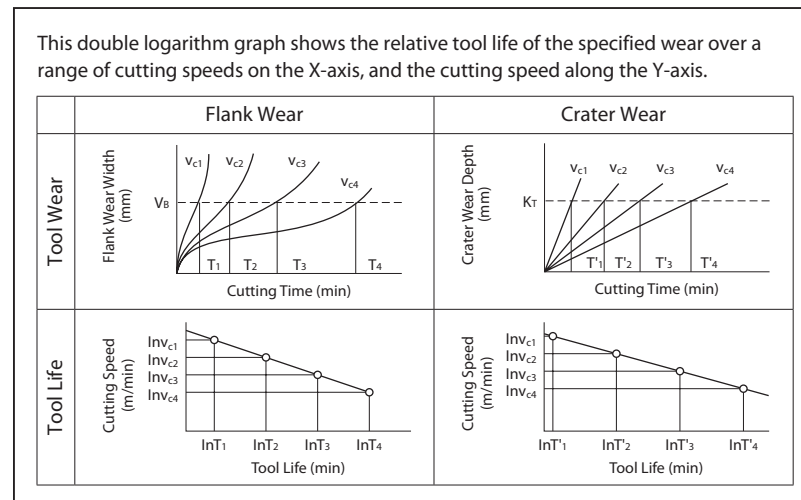

Flank Wear	Crater Wear
	
<p>Wear is rapid initially, then it proceeds more gradually in proportion with cutting time until a certain limit, beyond which it increases rapidly again.</p>	<p>Crater wear is more progressive with no sudden breakdown pattern.</p>

Tool Life (V-T)

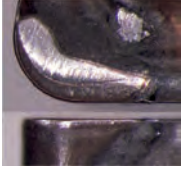

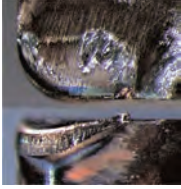
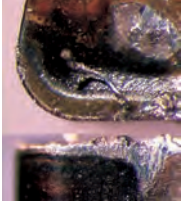

Troubleshooting for Turning







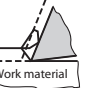



	Failure	Cause	Countermeasures
Tool Edge Failure	Flank Wear 	<ul style="list-style-type: none"> Grade lacks wear resistance. Rake angle is too small. Cutting speed is too fast. Feed rate is far too slow. 	<ul style="list-style-type: none"> Select a wear-resistant grade. P30 → P20 → P10 K20 → K10 → K01 Use an insert with a larger rake angle. Decrease the cutting speed Increase feed rates.
	Crater Wear 	<ul style="list-style-type: none"> Grade lacks crater resistance. Rake angle is too small. Cutting speed is too fast. Feed rate is too fast. Depth of cut is too large. 	<ul style="list-style-type: none"> Select a crater-resistant grade. Select a grade with a smooth coating. Use an insert with a larger rake angle. Select an appropriate chipbreaker. Decrease the cutting speed Reduce feed rates and depth of cut.
	Chipping 	<ul style="list-style-type: none"> Grade lacks toughness. Insert falls off due to chip build-up. Cutting edge lacks toughness. Feed rate is too fast. Depth of cut is too large. 	<ul style="list-style-type: none"> Select a tougher grade. P10 → P20 → P30 K01 → K10 → K20 Select a more adhesion-resistant grade. Coated carbide or cermet grades. Increase amount of honing on cutting edge. Reduce rake angle. Reduce feed rates and depth of cut.
	Fracture 	<ul style="list-style-type: none"> Grade lacks toughness. Cutting edge lacks toughness. Holder lacks toughness. Feed rate is too fast. Depth of cut is too large. 	<ul style="list-style-type: none"> Select a tougher grade. P10 → P20 → P30 K01 → K10 → K20 Select a chipbreaker with a strong cutting edge. Select a holder with a larger approach angle. Select a holder with a larger shank size. Reduce feed rates and depth of cut.
	Built-up Edge 	<ul style="list-style-type: none"> Inappropriate grade selection. Dull cutting edge. Cutting speed is too slow. Feed rate is too slow. 	<ul style="list-style-type: none"> Select a grade with less affinity to the work material. Coated carbide or cermet grades. Select a grade with a smooth coating. Use an insert with a larger rake angle. Reduce amount of honing. Increase cutting speeds. Increase feed rates.
	Plastic Deformation 	<ul style="list-style-type: none"> Grade lacks thermal resistance. Rake angle is too small. Cutting speed is too fast. Feed rate is too fast. Depth of cut is too large. Not enough cutting fluid. 	<ul style="list-style-type: none"> Select a thermal-resistant grade. Use an insert with a larger rake angle. Decrease the cutting speed Reduce feed rates and depth of cut. Supply appropriate amount of coolant.
	Notch Wear 	<ul style="list-style-type: none"> Grade lacks wear resistance. Rake angle is too small. Cutting speed is too fast. Feed rate is too fast. Depth of cut is fixed. 	<ul style="list-style-type: none"> Select a wear-resistant grade. P30 → P20 → P10 K20 → K10 → K01 Select a grade with a smooth coating. Use an insert with a larger rake angle. Decrease the cutting speed Reduce feed rate. Alter depth of cut to shift the notch location.



Type of Chip Generation

	Spiralling	Shearing	Tearing	Cracking
Shape				
Condition	Continuous chips with good surface finish.	Chip is sheared and separated by the shear angle.	Chips appear to be torn from the surface.	Chips crack before reaching the cutting point.
Application	Steel, Stainless steel	Steel, Stainless steel (Low speed)	Steel, Cast iron (very low speed, very small feed rate)	Cast iron, Carbon
Influence Factor	Easy ← Work deformation → Difficult Large ← Rake angle → Small Small ← D.O.C. → Large Fast ← Cutting speed → Slow			

Type of Chip Control

Chip Types	Depth	A	B	C	D	E
	Large					
Small						
Evaluation	NC Lathe (For Automation)	H	H	S	S	J
	General Lathe (For Safety)	H	S	S	S-J	H

Good: C type, D type
 A type: Twines around the tool or workpiece, damages the machined surface and affects safety.
 Poor B type: Causes problems in the automatic chip conveyor and chipping occurs easily.
 E type: Causes spraying of chips, poor machined surface due to chattering, chipping, large cutting force and high temperatures.

Factor of Improvement Chip Control

(1) Increase Feed Rate (f mm/rev)

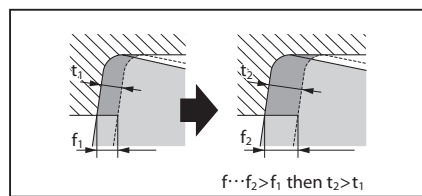

When feed rate increases, chips become thick and chip control improves.

(2) Decrease Side Cutting Edge (θ)

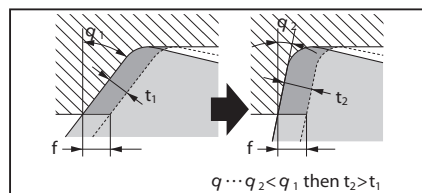

Even if feed rate is the same, smaller side cutting edge angle makes chips thick and chip control improves.

(3) Decrease Nose Radius (r_e)

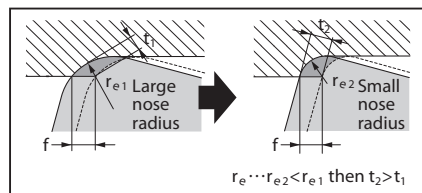

Even if feed rate is the same, a smaller nose radius makes chip thick and chip control improves.

* Cutting force increases in proportion with the length of the contact surface. Therefore, a larger nose radius increases back force which induces chattering. With the same feed rate, a smaller nose radius produces a rougher surface finish.

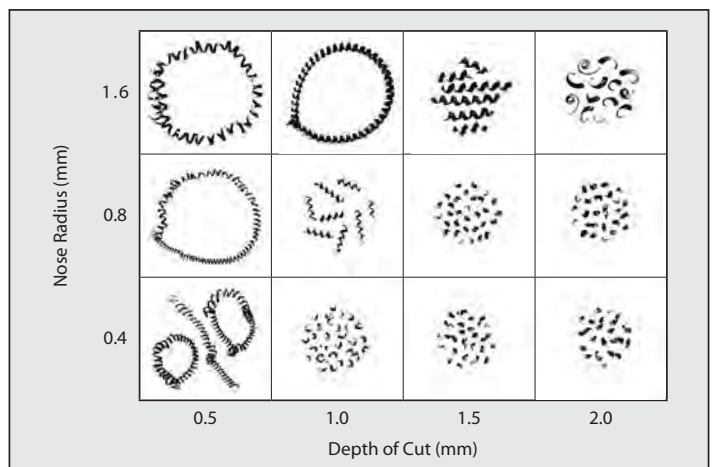
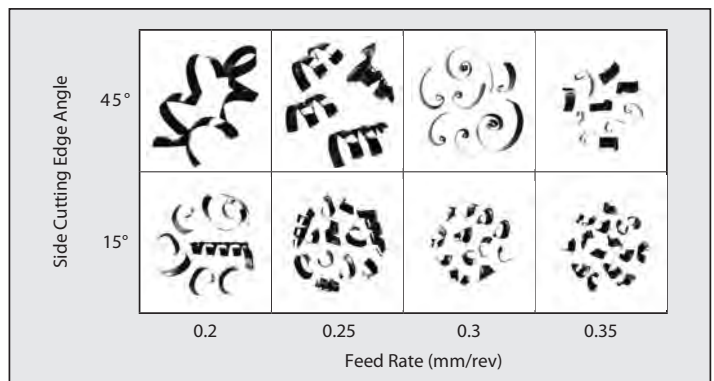
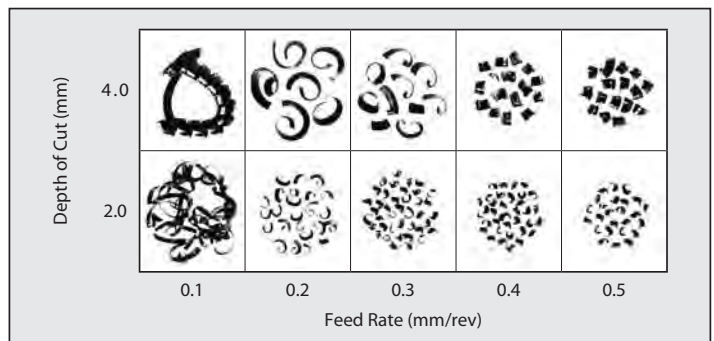

SUMIBORON PCBN GRADES

SumiBoron PCBN Grades

Sumitomo Electric is a world leader in the development of polycrystalline diamond and PCBN cutting tool materials and their applications. For you, this means increased productivity, better surface finish, the ability to hold closer tolerances, and longer tool life. Sumitomo offers products in sizes and grades available nowhere else.

In general, polycrystalline cutting tools are recommended for machining materials that are too hard or abrasive for conventional cutting tools such as tungsten carbide, cermets, or ceramics. Cubic boron nitride is used for ferrous materials and diamond for nonferrous and nonmetal applications.

In 1977, Sumitomo successfully developed its own revolutionary CBN sintered material - SumiBoron. Manufactured under ultra-high temperature and pressure sintering of a mixture of cubic boron nitride and a special ceramic binder material. Compared to conventional tooling materials, SumiBoron exhibits higher hardness and exceptional heat resistance, allowing it machining capabilities previously accomplished only by grinding. SumiBoron also achieves excellent efficiency and longer tool life in high speed machining of cast irons.



■ CBN CLASSIFICATIONS

PCBN is generally classified into two groups based on its material microstructure. PCBN particles of the first type are bonded together directly. The percentage of PCBN in this type is very high, resulting in an extremely hard substrate.

SumiBoron, representative of the second type of PCBN materials, consists of PCBN particles bonded together with a ceramic binder. The bonding strength is very high, making the substrate very wear resistant and tough.

A third type of PCBN features enhancements of ceramic based coatings to new Sumitomo PCBN grades. They offer increased wear resistance as well as the ability to achieve higher speeds and superior surface finishes in a multitude of hardened steel applications.

■ Classifications/ Applications

	Classifications	Structure	Diagram	Grade	Work Material
A)	Mainly CBN grains fused together			BN700	K Cast Iron (FC) S Sintered Alloy
				BN7000	S Exotic Alloys
				BN7500	S Sintered Alloy
				BNS800	K Cast Iron (FC) S Exotic Alloys
B)	Mainly CBN grains held together with a binder			BN1000	H Hardened Steel
				BN2000	
				BN350	
				BNX10	
				BNX20	
				BNX25	
C)	Sintered CBN body with special ceramic coating			BNC2010	H Hardened Steel
				BNC2020	
				BNC300	
				BNC100	
				BNC160	
				BNC200	
	BNC500	K Cast Iron (FCD)			



■ Coated Grades for Turning

- How they compare to other insert materials

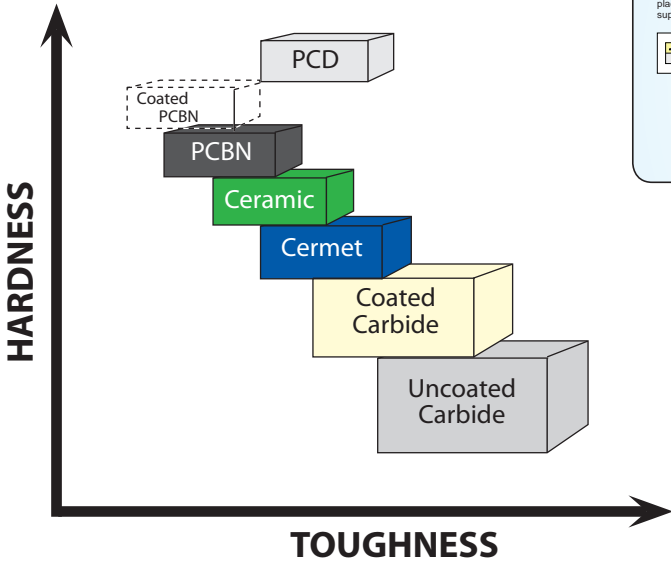

■ MANUFACTURING PROCESS of P_cBN

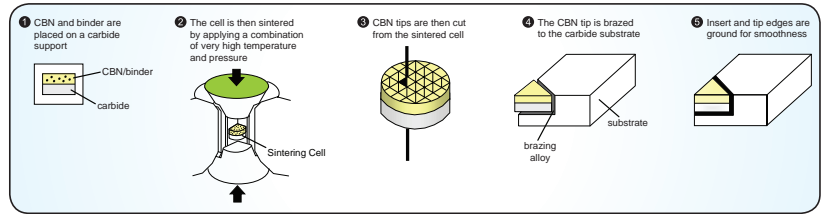

■ Application Range

● Induction Hardened Steel (S45C / S55C etc.), Carburized steel

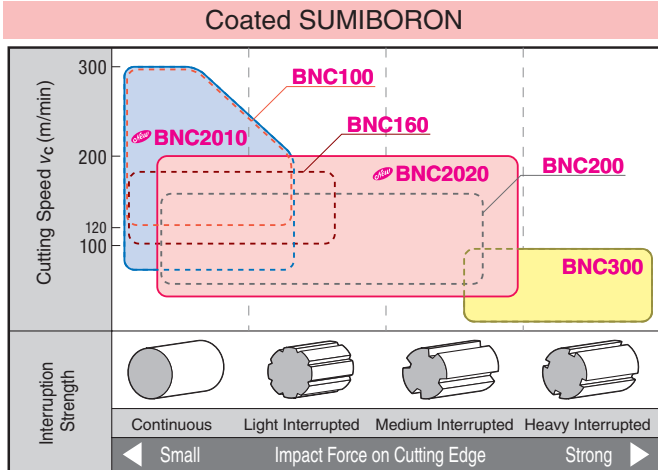

● Induction Hardened Steel (S45C / S55C etc.), Carburized steel

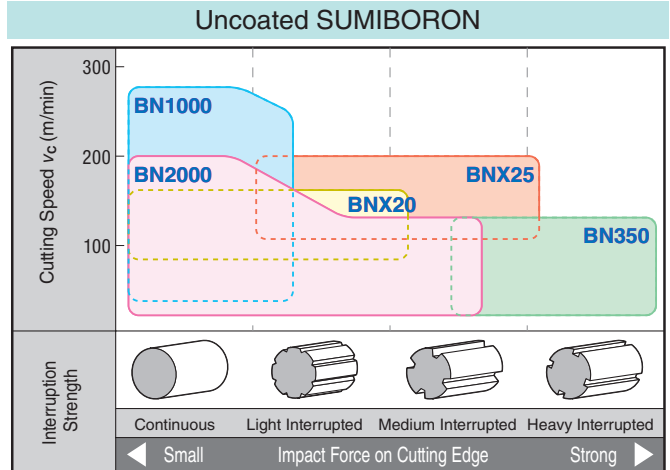

● Die Steel (SKD11 / SKD61 etc.), HSS

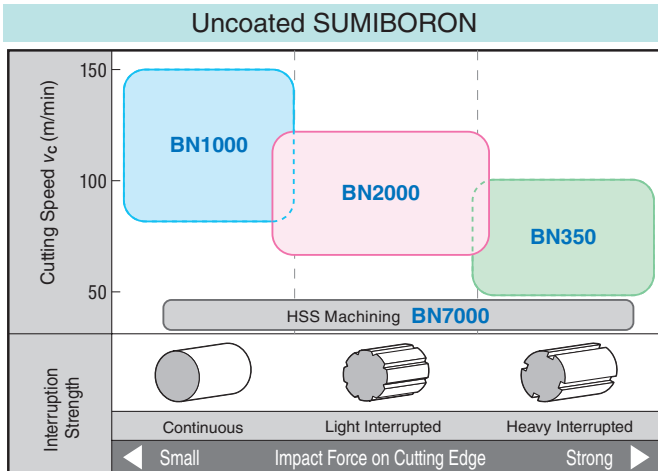

■ Recommended Cutting Conditions

	Grade	Cutting Speed v_c (m/min)					f (mm/rev)	a_p (mm)
		50	100(120)	150(170)	200(220)	250 300		
Coated	BNC2010	[Bar chart]					0.03 to 0.25	0.03 to 0.35
	BNC2020	[Bar chart]					0.03 to 0.40	0.03 to 0.50
	BNC300	[Bar chart]					0.03 to 0.20	0.03 to 0.30
	BNC100	[Bar chart]					0.03 to 0.20	0.03 to 0.30
	BNC160	[Bar chart]					0.03 to 0.20	0.03 to 0.35
	BNC200	[Bar chart]					0.05 to 0.35	0.05 to 0.50
Uncoated	BN1000	[Bar chart]					0.03 to 0.15	0.03 to 0.20
	BN2000	[Bar chart]					0.03 to 0.20	0.03 to 0.30
	BN350	[Bar chart]					0.03 to 0.20	0.03 to 0.30
	BNX10	[Bar chart]					0.03 to 0.15	0.03 to 0.20
	BNX20	[Bar chart]					0.03 to 0.30	0.03 to 0.50
	BNX25	[Bar chart]					0.03 to 0.30	0.03 to 0.50



■ Machining of Hardened Steel versus Grinding

- **REDUCTION IN EQUIPMENT COST** - Lathes are generally two to three times less expensive than grinding machines.
- **INCREASE PRODUCTION CAPACITY** - Automation of turning machine centers means more parts in less time.
- **SAVE TIME** - By turning, parts with complicated shapes can be machined in one process.
- **IMPROVED QUALITY** - Turning improves part perpendicularity and concentricity because multiple operations can be performed without re-chucking.
- **REDUCED SET-UP TIME** - Only simple NC program changes are needed to machine parts of different sizes.
- **REDUCTION OF INDUSTRIAL WASTE** - Turning eliminates the expense and environmental problems associated with grinding sludge.

	Benefit	Details
Cost	Facility investment is low	<ul style="list-style-type: none"> • Cheaper machines • Improved efficiency w/less machining required
	Profile finishing in one set-up	
Quality	Improved precision	
Waste Reduction	Less industrial waste	Sludge management vs. chip management (recyclable)

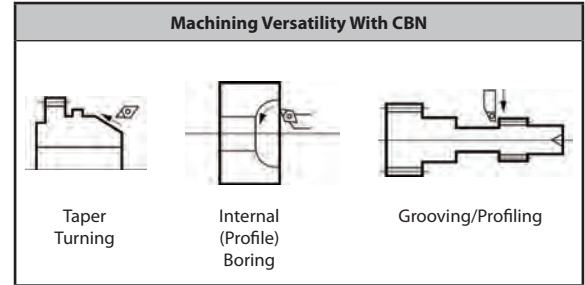

■ Recommended Grade

	Grade	Binder	Carbon Content (%)	Grain Size (µm)	Hardness (GPa)	TRS (GPa)	Main Coating Components	Coating Thickness (µm)	Characteristics
Coated	BNC2010	TiCN	50 to 55	2	30 to 32	1.10 to 1.20	TiCN multi-layered	1.5	Improved wear resistant coating and substrate achieve excellent and stable surface roughness.
	BNC2020	TiN	70 to 75	5	34 to 36	1.20 to 1.30	TiAlN multi-layered	1.5	Provides long tool life in general and high-efficiency cutting thanks to tough substrate coated with a highly wear-resistant, highly adhesive layer.
	BNC300	TiN	60 to 65	1	33 to 35	1.15 to 1.25	TiAlN	1	Suitable for finishing work materials with both continuous and interrupted cutting.
	BNC100	TiN	40 to 45	1	29 to 32	1.05 to 1.15	TiAlN/TiCN	2	Suitable for high-speed finishing thanks to highly wear-resistant coating.
	BNC160	TiN	60 to 65	3	31 to 33	1.10 to 1.20	TiAlN/TiCN	2	Achieves stable, high-precision finishing of hardened steel.
	BNC200	TiN	65 to 70	4	33 to 35	1.15 to 1.25	TiAlN	2	Provides long tool life thanks to tough substrate and highly wear-resistant coating.
Uncoated	BN1000	TiCN	40 to 45	1	27 to 31	0.90 to 1.00	—	—	Achieves ultimate wear and fracture resistance. Suitable for high-speed cutting.
	BN2000	TiN	50 to 55	2	31 to 34	1.05 to 1.15	—	—	General-purpose grade for hardened steel machining with high degree of fracture and wear resistance.
	BNX20	TiN	55 to 60	3	31 to 33	0.95 to 1.10	—	—	Achieves excellent crater wear resistance. Suitable for high-efficiency cutting under high temperature conditions.
	BNX350	TiN	60 to 65	1	33 to 35	1.20 to 1.30	—	—	Achieves ultimate cutting edge strength. Suitable for heavy interrupted cutting.
	BNX10	TiCN	40 to 45	3	27 to 31	0.80 to 0.90	—	—	Excellent wear resistance. Suitable for continuous high-speed cutting.
	BNX25	TiN	65 to 70	4	29 to 31	1.00 to 1.10	—	—	Exhibits superior fracture resistance in high speed cutting. Suitable for high-speed interrupted cutting of hardened steel.

■ Application Range

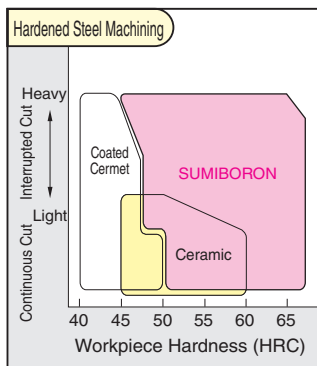

Application	Conditions	Cutting Speed (m/min)		
		100	200	300
Finishing	General Purpose (Continuous to Light Interrupted Rz=Above 3.2)			
	Medium to Heavy Interrupted			
High Precision (Rz=16 to 3.2)	Coated SUMIBORON			
	Uncoated SUMIBORON			
High Efficiency (Carburized layer removal)	Coated SUMIBORON			
	Uncoated SUMIBORON			



One-use Insert NC Type/ NU Type/NS Type

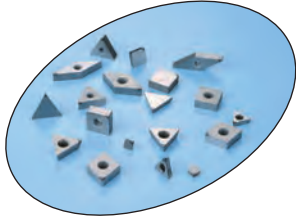

■ CHARACTERISTICS

- Affordable version of the once expensive sintered CBN material, at its optimal size.
- One-use type eliminates regrinding thus making tool management simple.
- Reduce required storage space with 10 piece packaging.

Multi-cornered, One-use Insert

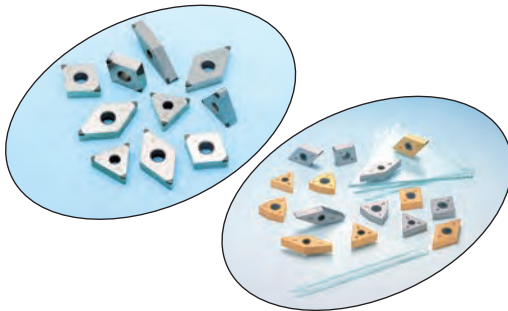

■ CHARACTERISTICS

- Insert with several brazed SUMIBORON one-use corners. Price per edge is more reasonable compared to normal single cornered, one use type insert.
- Coated SUMIBORON is available as a double-faced insert. Diamond shaped inserts have 4 cutting edges and triangle shaped inserts have 6 cutting edges, etc.
- Multi-cornered, one-use type has G-class specification with ground side faces. In addition, all edges are numbered for easy cutting edge management.

One-use Wiper Insert

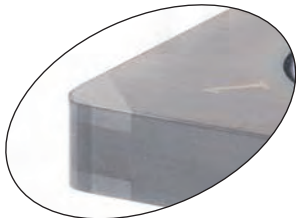

■ CHARACTERISTICS

- SUMIBORON one-use insert with wiper edge is for hardened steel machining.
- Standard wiper, W features excellent surface roughness comparable to grinding.
- Multi-cornered, one-use type has G-class specification with ground side faces. In addition, all edges are numbered for easy cutting edge management.
- Radial wipers, WG & WH improves surface roughness and finish repeatability.

One-use insert with chipbreaker

SV, LV, FV Type

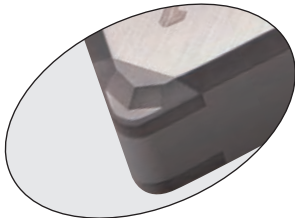

■ CHARACTERISTICS

- SUMIBORON One-use insert with chipbreaker, especially for carburized layer removal.
- Breaker included on the CBN edge, chipbreaking effect can be maintained throughout.
- Unique breaker design can be applied to both hardened and non-hardened parts with effective chip control.

Solid SUMIBORON

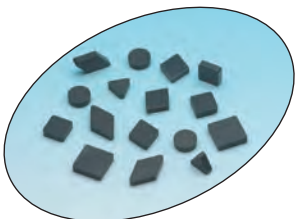

■ CHARACTERISTICS

- 100% solid CBN structure. With no brazed portion, this grade is excellent for the roughing of cast iron at large depth of cut.

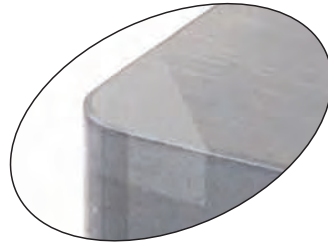
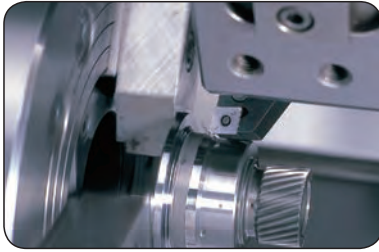

■ Characteristics

- SUMIBORON one-use insert with wiper flat for Hardened Steel machining.
- Excellent surface finish similar to grinding
- Improved efficiency with higher speeds and feeds
- Lineup includes WG type for low-feed cutting and WH type for high-feed cutting.

■ Purpose of Wiper Edge

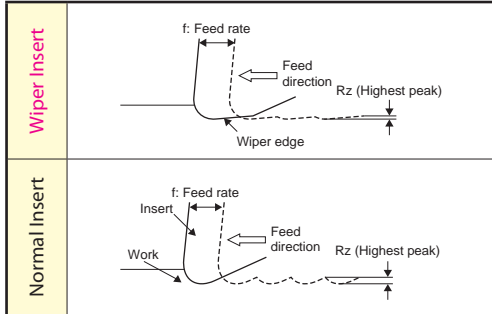

■ Surface Roughness of Wiper Insert

	Wiper Insert (WG Type/WH Type)		Standard Insert (No Wiper)	
	Low feed cutting (f = 0.10)	High feed cutting (f = 0.30)	Low feed cutting (f = 0.10)	High feed cutting (f = 0.30)
Surface Roughness Profile				
Surface Roughness Rz (Highest peak)	0.63 μm	1.39 μm	1.98 μm	9.20 μm

The wiper flat offers good surface finish and improved efficiency.

■ Recommended Cutting Conditions (Surface Roughness Standard: 1.6s to 3.2s)

- For optimum effectiveness, use wiper inserts for continuous cutting. For copy turning, inserts with nose-radius are recommended.
- Chattering and undulation may occur, please use work material and machines with high rigidity.

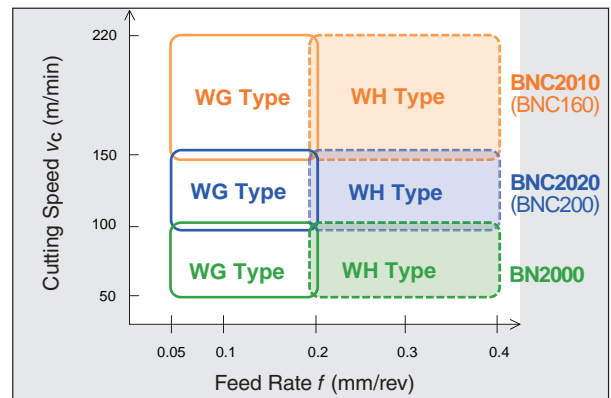

WG Type: Recommended feed rate of $f = 0.20$ or lower (Surface Finish Rz = 1.6 to 3.2 μm)
 WH Type: Recommended feed rate of $f = 0.20$ or higher (Surface Finish Rz = 1.6 to 3.2 μm)
 Lineup includes five grades (BN2000, BNC2010, BNC2020, BNC200, BNC160) to suit different cutting speeds.

■ Application Example

Condition	Work	Tool	Cutting Conditions	Results
	1. Part Name 2. Grade	Insert	v_c = Cutting Speed (m/min) f = Feed Rate (mm/rev) a_p = Depth of cut (mm)	
CVJ Outer Race Facing 	1. CVJ Outer Race 2. Carburized steel 58 to 62HRC Required finish Rz=1.6μm	4NC-CNGA120412WH (BNC2010)	$v_c = 150$ m/min $f = 0.20$ mm/rev $a_p = 0.2$ mm Dry	BNC2010 (WH Type) 700 pcs Comp. (No wiper) 400 pcs
Shaft Ext. Turning 	1. Shaft 2. Carburized steel 58 to 62HRC Required finish Rz=6.3μm	4NC-DNGA150408WG (BNC2010)	$v_c = 140$ m/min $f = 0.20$ mm/rev $a_p = 0.15$ mm Dry	BNC2010 (WG Type) 500 pcs Comp. (No wiper) 350 pcs



SUMIBORON Insert and Edge Treatment

All SUMIBORON inserts are enhanced with the optimum cutting edge preparation for the various grades and geometries (shown on the right). This is to avoid cutting edge fracture caused by the heavy loads generated during the machining of high hardness materials such as Hardened Steel. As the pioneer of CBN tools "SUMIBORON," this vast selection of grades and edge treatment combinations is our trump card for Hardened Steel machining.

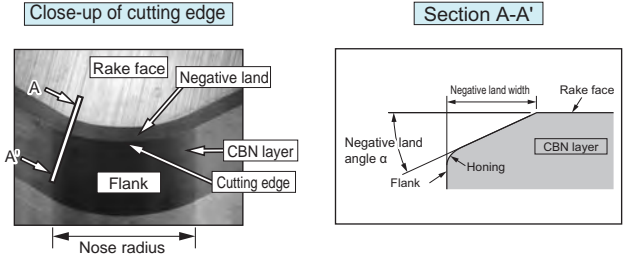

SUMIBORON Insert Cutting Edge Specification List

Series	Work Material	Grade	Negative/Positive	Standard				Low Resistance Type L				Strong Edge Type H					
				Identification Code	R	W	Honing	Notation	Identification Code	R	W	Honing	Notation	Identification Code	R	W	Honing
Uncoated SUMIBORON	Hardened Steel	BNX10	Negative/Positive	T01225	25°	0.12	No	-	-	-	-	-	-	-	-	-	-
		BNX20	Negative/Positive	S01225	25°	0.12	Yes	LT	T01215*	15°	0.12	No	-	-	-	-	-
		BNX25	Negative/Positive	S01725	25°	0.17	Yes	-	-	-	-	-	-	-	-	-	-
		BN1000	Negative/Positive	S01225	25°	0.12	Yes	-	-	-	-	-	-	-	-	-	-
		BN250	Negative	S01225	25°	0.12	Yes	LT	T01215	15°	0.12	No	-	-	-	-	-
			Positive	S01235	35°	0.12	Yes	LS	S01225	25°	0.12	Yes	-	-	-	-	-
		BN2000	Negative/Positive	S01225	25°	0.12	Yes	LT	T01215	15°	0.12	No	HS	S01235	35°	0.12	Yes
	BN350		Negative	T01225	25°	0.12	No	-	-	-	-	-	HT	T01235	35°	0.12	No
		Positive	T01235	35°	0.12	No	-	-	-	-	-	-	-	-	-	-	
	Cast Iron Exotic Alloy	BN500	Negative/Positive	T01215	15°	0.12	No	-	-	-	-	-	-	-	-	-	-
BN700		Negative/Positive	T01215	15°	0.12	No	LF	Sharp edge	0°	0	No	HS	S01225	25°	0.12	Yes	
BN7000		Negative/Positive	T01215	15°	0.12	No	LF	Sharp edge	0°	0	No	HS	S01225	25°	0.12	Yes	
		BN7500	Negative/Positive	T01215	15°	0.12	No	LE	Sharp edge	0°	0	Yes	HS	S00525	25°	0.05	Yes
BNS800			Negative	T02020	20°	0.20	No	LF	Sharp edge	0°	0	No	-	-	-	-	-
Coated SUMIBORON	Hardened Steel	BNC2010	Negative/Positive	S01225	25°	0.12	Yes	LE	Hone Only	0°	0	Yes	HS	S01730	30°	0.17	Yes
		BNC2020	Negative/Positive	S01225	25°	0.12	Yes	LT	T00515	15°	0.05	No	HS	S02735	35°	0.27	Yes
		BNC100	Negative/Positive	S01225	25°	0.12	Yes	LS	S01715	15°	0.17	Yes	-	-	-	-	-
			Negative/Positive	S01225	25°	0.12	Yes	LS	S01020	20°	0.10	Yes	HS	S01730	30°	0.17	Yes
		BNC200	Negative/Positive	S01225	25°	0.12	Yes	LS	S01015	15°	0.10	Yes	HS	S01735	35°	0.17	Yes
		BNC300	Negative/Positive	S01225	25°	0.12	Yes	LS	S00515	15°	0.05	Yes	HS	S01735	35°	0.17	Yes
	Cast Iron	BNC500	Negative/Positive	S01215	15°	0.12	Yes	-	-	-	-	-	HS	S01225	25°	0.12	Yes

Technical Information

* BNX20 Identification code will be T00715 for inserts with inscribed circle of less than φ4.76.

Cutting Edge Treatment of Inserts with Wipers/Chipbreakers

Series	Work Material	Grade	Other Types					
			Notation	Identification Code	α	W	Honing	Type
SUMIBORON	Hardened Steel	BN2000	WG	S01215	15°	0.12	Yes	Wiper
			WH	S01215	15°	0.12	Yes	Wiper
			N-FV	-	0°	0	Yes	With breaker
			N-LV	S00535	35°	0.05	Yes	With breaker
Cast Iron Exotic Alloy	BNS800	W	T02020	20°	0.20	No	Wiper	
		LFW	Sharp edge	0°	0	No	Wiper Sharp edge	
Coated SUMIBORON	Hardened Steel	BNC100	W	S01715	15°	0.17	Yes	Wiper
			BNC2010 BNC2020	WG	S01215	15°	0.12	Yes
		WH		S01215	15°	0.12	Yes	Wiper
		W		S01215	15°	0.12	Yes	Wiper
		N-FV		-	0°	0	Yes	With breaker
		N-LV		S00535	35°	0.05	Yes	With breaker
		N-SV		S01235	35°	0.12	Yes	With breaker
		BNC160 BNC200	WG	S01215	15°	0.12	Yes	Wiper
			WH	S01215	15°	0.12	Yes	Wiper
			W	S01215	15°	0.12	Yes	Wiper
			N-FV	-	0°	0	Yes	With breaker
			N-LV	S00535	35°	0.05	Yes	With breaker
		N-SV	S01235	35°	0.12	Yes	With breaker	
Cast Iron	BNC500	W	S01215	15°	0.12	Yes	Wiper	

Edge Treatment Identification Code

Edge Treatment Notation			
No	Standard type		
L	Low cutting forces	+	F Sharp edge
			E Honing
H	Strong edge type	+	T Negative land
			S Negative land + Honing
WG/WH/W	Wiper		
N-FV/N-LV/N-SV	With Chipbreaker		

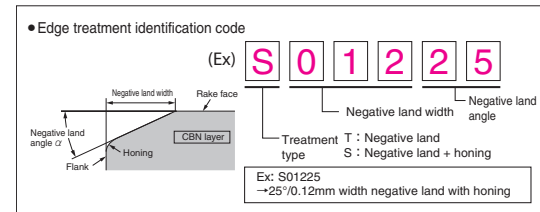

RECOMMENDED RUNNING CONDITIONS (SFM)

Material	Application	Hardness	Grade	Low	Low Opt.	High Opt.	High
INDUCTION HARDENED STEEL	Continuous	45-65HrC	BNC2010	450	650	750	1000
			BNC2020	400	550	600	800
			BN1000	400	550	650	700
			BNX10	400	500	650	700
			BNC160	400	550	650	800
			BNX20	300	450	550	600
			BNC200	350	500	650	750
	Interrupted (DRY)	45-65 HrC	BNC100	400	600	700	1000
			BN2000	300	400	550	600
			BNC2020	350	450	500	700
			BNX25	400	550	700	750
			BN2000	300	400	550	600
			BN350	300	400	550	600
			BNC300	300	400	550	600
BNC200	350	400	500	600			
CARBURIZED HARDENED STEEL BEARING STEEL	Continuous	45-65 HrC	BNC2010	450	600	750	1000
			BNC2020	350	450	600	800
			BNC160	350	450	550	600
			BNX20	250	300	500	600
			BNC200	300	350	550	650
			BNC100	350	425	550	675
			BN2000	300	400	550	600
	Interrupted (DRY)	45-65 HrC	BNC2020	300	450	550	700
			BNX25	400	550	700	750
			BN300	300	400	550	600
			BN350	300	400	550	600
			BNC200	300	400	550	650
			BNC300	300	400	550	600
			BNC300	300	400	550	600
DIE STEEL HIGH SPEED STEEL	Continuous	55-65 HrC	BNC2010	350	400	550	800
			BNC2020	250	350	500	700
			BN2000	150	250	450	550
			BN1000	250	300	450	650
			BNX10	250	300	400	500
			BNC160	250	300	400	500
			BNX20	150	200	300	450
	Interrupted (DRY)	55-65 HrC	BNC200	200	250	350	450
			BNC100	250	300	400	500
			BNC2020	200	300	400	600
			BN2000	150	200	250	300
			BNX25	300	400	500	550
			BN300	150	200	250	300
			BN350	150	200	250	300
BNC300	200	250	300	350			

Technical Information

FEED RATE

FEED RATE (IPR)		
Finishing	General Purpose	Roughing
0.002 - 0.004	0.004 - 0.006	0.006 - 0.008

Note: Use above speeds for threading and grooving applications.
The recommended feed rate for grooving is 0.001 - 0.002 IPR, while your threading feed rate should be based upon the thread form, but not to exceed 0.006 IPR.

DEPTH OF CUT

Mini-Tip (NU, NS, NC)	D.O.C. < 0.015"
Medium-Tip (MD)	D.O.C. < 0.020"
Full-Tip	D.O.C. < 0.020"

Note: Depth of cut per pass

Grade	General Running Parameters* (SFM)			
	Low	Low Opt.	High Opt.	High
BNC2010	400	550	700	900
BNC2020	200	400	600	850
BNX10	400	450	650	700
BNC160	400	450	650	720
BNX20	250	400	600	650
BNC200	200	350	650	820
BN250	200	250	400	500
BNX25	450	500	650	700
BN300	200	300	500	550
BN350	200	300	500	550
BNC100	400	525	675	850
BNC300	200	250	400	500

* The recommendations are a general range of running parameters based on grade and material. Please contact your local Sumitomo Sales Representative or the Sumitomo Engineering Department to obtain more application specific running parameters.

Note: Running wiper inserts at the above feed rates will produce a higher quality surface finish when compared to a non-wiper insert.



RECOMMENDED RUNNING CONDITIONS FOR CBN APPLICATIONS(SFM)

Material	Application	Grade	Low	Low Opt.	High Opt.	High
GRAY CAST IRON	Continuous & Interrupted	BN7000	2600	3000	5000	6500
		BN700	2300	3000	5000	6000
		BNS800	1000	2000	5500	6500
		BNC500	600	1000	2000	2500
		BN500	1500	2000	5500	6000
Material	Application	Grade	Low	Low Opt.	High Opt.	High
DUCTILE IRON 150 -300 HBn	Continuous & Interrupted	BNC500	650	800	1300	1650
		BN7000	300	450	550	650
		BN700	300	450	550	600
Material	Application	Grade	Low	Low Opt.	High Opt.	High
GENERAL SINTERED ALLOY	Continuous & Interrupted	BN700	400	550	800	1000
		BN7000	400	550	800	1000
		BN7500	400	550	650	1000
Material	Application	Grade	Low	Low Opt.	High Opt.	High
HIGH DENSITY SINTERED ALLOY	Continuous & Interrupted	BN7500	65	450	550	750
		BN7000	65	450	550	750
		BN700	65	450	550	750
		BNS800	65	450	550	750

Technical Information

FEED RATE

FEED RATE (IPR)		
Finishing	General Purpose	Roughing
0.002 - 0.004	0.004 - 0.006	0.006 - 0.008

Note: Use above speeds for threading and grooving applications.
The recommended feed rate for grooving is 0.001 - 0.002 IPR, while your threading feed rate should be based upon the thread form, but not to exceed 0.006 IPR.

Grade	General Running Parameters* (SFM)			
	Low	Low Opt.	High Opt.	High
BN500	500	800	1500	2000
BNS800	2000	3000	5000	6000
BN700	2000	3000	5000	6000

* The above are a general range of running parameters based on grade and material. Please contact your local Sumitomo Sales Representative or the Sumitomo Engineering Department to obtain more application specific running parameters.
Coolant should not be used for any interrupted cutting when using PCBN tools

DEPTH OF CUT

Mini-Tip (NU, NS, NC)	D.O.C. ≤ 0.020"
Medium-Tip (MD)	D.O.C. ≤ 0.040"
Full-Tip	D.O.C. ≤ 0.040"
Solid CBN**	D.O.C. ≤ 0.150"

**Depth of cut based on gray cast iron material. For chilled iron, depth of cut should not exceed 0.080".

Note: The above running parameters are for turning applications only.





Since the introduction of SUMIDIA DA polycrystalline diamond (PCD) blanks in 1978, Sumitomo has continually developed and expanded the product line to offer finished inserts in a wide range of grades, shapes and sizes. SUMIDIA inserts consist of a layer of fine grain synthetic diamond crystals bonded to a tungsten carbide substrate which is securely brazed into the pocket of a standard size insert. A high degree of diamond to diamond bonding is achieved by an ultra high pressure-temperature process. This crystal to crystal bonding provides exceptional hardness and abrasion resistance.

Our closely controlled manufacturing process produces unequalled consistency resulting in superior tool edge quality.

SUMIDIA DA inserts and wipers are replacing tungsten carbide and natural diamond cutting tools on a worldwide basis. Use of SUMIDIA DA grades will provide dramatically increased tool life, the ability to hold closer part tolerance, and improved surface finish.

New technological advances have given the industry a new style of PCD insert. The optimum size of PCD used in NF-DA2200 offers a less expensive alternative when machining non-ferrous materials.

■ GRADE DESCRIPTION

Grade	DA1000	DA2200	DA150	DA90
Average diamond crystal size (microns)	Up to 0.5	0.5	5	~ 50
Hardness (Hv)	11,000-12,000	9,000-10,000	10,000-12,000	10,000-12,000
T.R.S. (kg/mm ²)	260	250	200	115
Product Description	<ul style="list-style-type: none"> • Ultra-fine grain structure • Superior hardness and wear resistance with sharp edge 	<ul style="list-style-type: none"> • High density sintered material made of ultra-micro diamond particles • Superior hardness and wear resistance with sharp edge 	<ul style="list-style-type: none"> • Fine grain diamond • High abrasion resistance 	<ul style="list-style-type: none"> • Coarser grain • High wear resistance
Applications	<ul style="list-style-type: none"> • High Silicon Aluminum • Copper • Fiberglass • Hard rubber • Graphite epoxy • Wood • Aluminum alloys (finishing, roughing, interrupted) • Plastics • Carbon 	<ul style="list-style-type: none"> • High silicon Aluminum • Copper • Fiberglass • Hard rubber • Graphite epoxy • Wood • Aluminum alloys (finishing, roughing, interrupted) 	<ul style="list-style-type: none"> • High silicon aluminum • Copper • Fiberglass • Hard rubber • Graphite epoxy • Wood • Carbon 	<ul style="list-style-type: none"> • Sintered carbide • Stone or rock • High silicon aluminum • Green or semi-sintered carbide & ceramic



Break Master LD / GD Type

General features

- Excellent chip control by 3D Chipbreaker
- Long tool life by high toughness grade DA1000

Characteristics/Applications

1 LD/GD type for various types of machining

- LD type for finishing application
- GD type for general purpose-machining

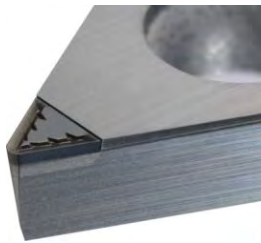

LD type

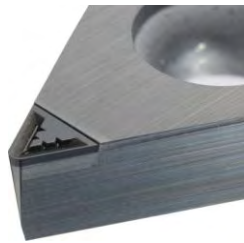

GD type

2 Long tool life – DA1000

- Long, stable tool life and good chipping resistance with high toughness grade DA1000

expanded material (A6061)

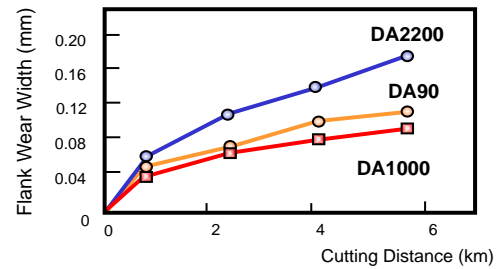
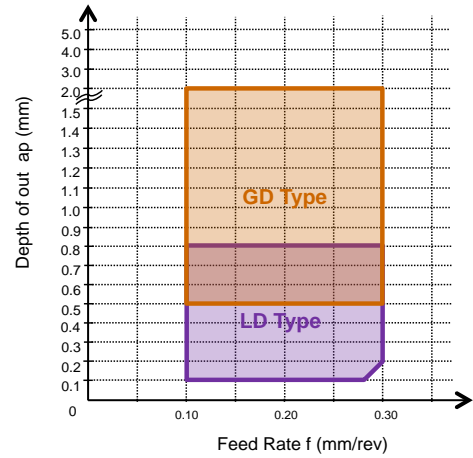

Workpiece: A390 (17%Si-Al)
Conditions: Vc=800m/min, f=0.12mm/rev, ap=0.5mm, Wet

Technical Information

RECOMMENDED RUNNING CONDITIONS FOR PCD APPLICATIONS

Material	SFM	IPR	D.O.C	Grade Recommendation		
				First	Second	Third
Aluminum Alloys (4% - 8% Si)	3,000 - 10,000	0.004 - 0.025	0.120"	DA1000	DA2200	DA150
Aluminum Alloys (9% - 14% Si)	2,000 - 8,000	0.004 - 0.020	0.120"	DA1000	DA2200	DA150
Aluminum Alloys (15% - 18% Si)	1,000 - 2,300	0.004 - 0.015	0.120"	DA1000	DA2200	DA150
Copper Alloy	3,300	0.002 - 0.008	0.120"	DA1000	DA2200	DA150
Hard Plastic	3,300	0.004 - 0.012	0.080"	DA1000	DA2200	DA150
Wood & Composite	13,000	0.004 - 0.015	-	DA1000	DA2200	DA150
Tungsten Carbide	30 - 70	0.003 - 0.008	0.020"	DA90	DA150	-
Reinforced Plastics	3,300	0.016	0.080"	DA1000	DA2200	DA150

Note: The above running parameters are for turning applications only.



Sumitomo Electric has developed TME (external) and TMI (internal) threading inserts with a pitch range of 1.0 ~ 3.0 mm and 8~24 threads per inch (TPI) along with applicable LTE type and STI holders. The superior features of the TME and TMI threading inserts include an M-class tolerance and dimple shaped chipbreaker. The M-class tolerance reduces insert cost by eliminating the need for expensive grinding. Furthermore, chip control is greatly improved as a result of the specially designed dimple chipbreakers.

FEATURES

- A positive rake angle encourages good chip control and reduces cutting resistance.
- Two tier dimple-style chip breakers evacuate chips smoothly and easily.
- M-class tolerance reduces insert cost.
- Four available grades cover a wider range of applications.

INSERT GRADES & RECOMMENDED RUNNING CONDITIONS

Application

AC225 (Coated)

- For stainless and general steels
- Stable machining

T130A (Cermet)

- For soft and general steels
- Good surface finish
- Long tool life

A30 (P30 Carbide)

- For low and medium speed cutting of stainless and general steels

EH20Z (PVD Coated)

- For exotic materials

Recommended Running Conditions (SFM)

Work Material \ Insert Grade	AC225	T130A	A30	EH20Z
Soft Steel	500 ~ 660	330 ~ 500	230 ~ 400	—
Carbon Steel	330 ~ 550	260 ~ 430	230 ~ 330	—
Alloy Steel	300 ~ 500	260 ~ 400	230 ~ 330	—
Stainless Steel	230 ~ 450	—	230 ~ 330	—
Exotics	—	—	—	100 ~ 150

Recommended Infeed Values mm (inch)

Pitch (mm) \ TPI	Pitch (mm)						
	1.0	1.25	1.5	1.75	2	2.5	3
Pass	24	19	16	14	12	9	8
1 ST	0.25 (.010)	0.25 (.010)	0.30 (.012)	0.30 (.012)	0.30 (.012)	0.35 (.014)	0.35 (.014)
2 ND	0.20 (.008)	0.20 (.008)	0.25 (.010)	0.25 (.010)	0.25 (.010)	0.30 (.012)	0.30 (.012)
3 RD	0.15 (.006)	0.15 (.006)	0.20 (.008)	0.20 (.008)	0.20 (.008)	0.25 (.010)	0.25 (.010)
4 TH	0.10 (.004)	0.15 (.006)	0.15 (.006)	0.15 (.006)	0.20 (.008)	0.20 (.008)	0.20 (.008)
5 TH	0.05 (.002)	0.10 (.004)	0.10 (.004)	0.15 (.006)	0.15 (.006)	0.20 (.008)	0.20 (.008)
6 TH	—	0.05 (.002)	0.05 (.002)	0.10 (.004)	0.12 (.005)	0.15 (.006)	0.15 (.006)
7 TH	—	—	—	0.05 (.002)	0.10 (.004)	0.15 (.006)	0.15 (.006)
8 TH	—	—	—	—	0.05 (.002)	0.10 (.004)	0.15 (.006)
9 TH	—	—	—	—	—	0.05 (.002)	0.10 (.004)
10 TH	—	—	—	—	—	—	0.10 (.004)
11 TH	—	—	—	—	—	—	0.05 (.002)

TME Insert Design

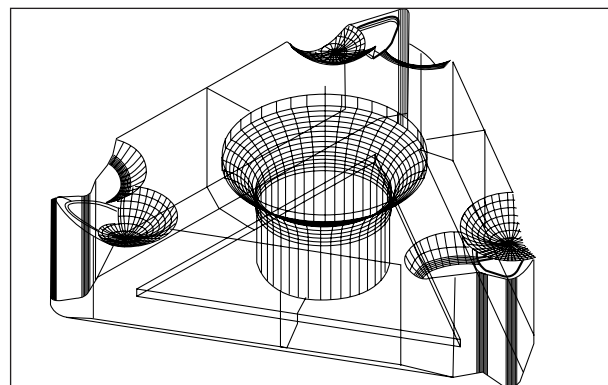

Trouble Shooting

- **Chipping**
T130A → AC225
- **Excessive Wear**
A30 → AC225 → T130A
- **Plastic Deformation**
A30 → AC225 → T130A

TERMS:**Thread Form** – (most common shapes)

60° (UN standard, ISO) 55° (British standard) 29° (Acme standard/stub)

Pitch – Distance from the top of one thread to the next.

Pitch = 1 (inch) / threads per inch, Ex: 20 TPI = 1 / 20 = .050

T.P.I. – Number of threads per inch

TPI = 1 (inch) / pitch, Ex: 1 / .050 (pitch) = 20 tpi

Lead – Movement caused by one revolution of the screw.

(the same as pitch in a single start thread)

Lead = pitch x number of starts

Example: double start thread with .050 pitch = .100 lead

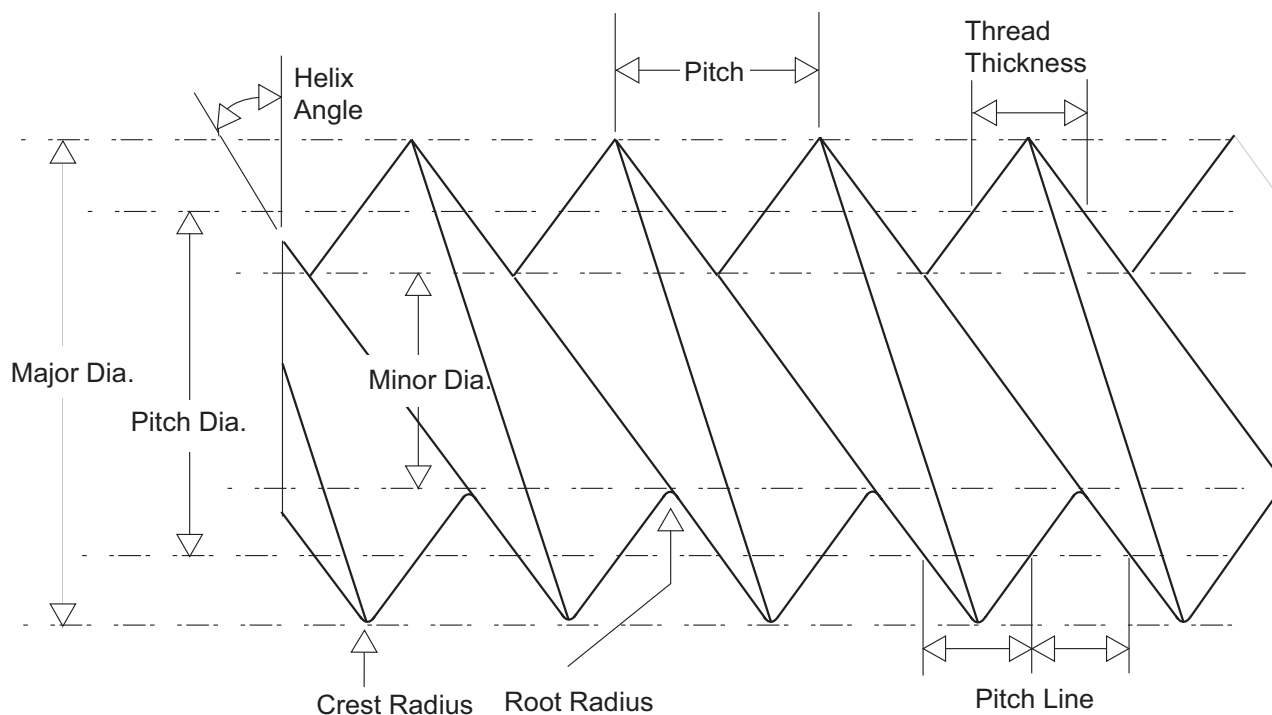
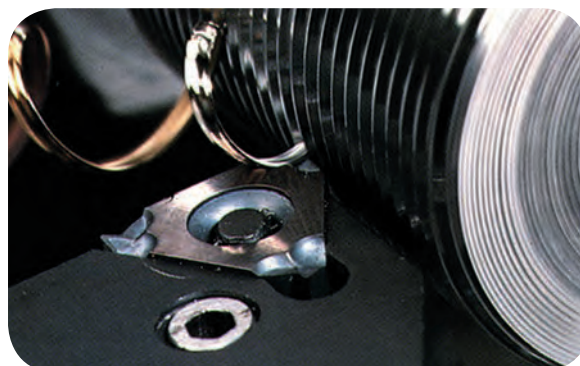
Multi-Start Thread – Thread with more than one starting position. (lead different than pitch)**Helix angle** – Angle generated by the helix of the thread at the pitch diameter.**Major Diameter** – see drawing below**Minor Diameter** – see drawing below**Pitch Diameter** – see drawing below**Pitch Line** – see drawing below**Crest and Root Radius** – see drawing below

Recommended first choice, Recommended second choice, Recommended third choice

Work Material	Hardness	Grade	Machining Parameters			
			Finishing .002 ~ .008 IPR. 005" ~ .060" D.O.C.	Gen. Purpose .008 ~ .020 IPR .040" ~ .200" D.O.C.	Roughing .008 ~ .020 IPR .040" ~ .200" D.O.C.	
LOW CARBON STEELS 1005, 1006, 1008, 1009, 1010, 1011, 1012, 1013, 1015, 1016, 1017, 1018, 1019, 1020, 1021, 1022, 1023, 1025, 1026, 1029, 1108, 1109, 1110, 1115, 1116, 1117, 1118, 1119, 1211, 1212, 1213, 1215, 1513, 1518, 1522	<250	T1500A	800~1650	800~1450	-	
		T1500Z	800~1750	800~1550	-	
		AC805P	800~1750	800~1550	700~1200	
		AC810P	800~1600	800~1400	700~1100	
		AC8025P	350~1200	350~1000	350~900	
		AC820P	500~1200	500~1000	400~900	
		AC830P	-	500~900	400~850	
	220~350	T1500A	700~1300	700~1200	-	
		T1500Z	700~1450	700~1300	-	
		AC805P	700~1300	700~1200	600~1100	
		AC810P	700~1200	700~1100	600~950	
		AC8025P	350~1000	350~900	350~800	
		AC820P	500~1000	500~900	400~800	
		AC830P	-	500~800	400~750	
	HRc 35~55	T1500A	400~750	400~650	-	
		T1500Z	400~800	400~750	-	
		AC805P	400~750	400~650	350~600	
		AC810P	400~600	400~550	350~550	
		AC8025P	250~500	250~450	250~450	
		AC820P	300~500	300~450	300~450	
		AC830P	250~450	200~400	200~400	
	LOW/MEDIUM CARBON STEEL -- LEADED 10L18, 10L45, 10L50, 11L17, 11L37, 11L41, 11L44, 12L13, 12L14, 12L15	<250	T1500A	1000~1650	1000~1550	-
			T1500Z	1000~1750	1000~1650	-
			AC805P	1000~1650	1000~1550	900~1450
			AC810P	1000~1500	1000~1400	900~1300
			AC8025P	600~1400	550~1300	500~1100
			AC820P	800~1400	750~1300	600~1100
			AC830P	-	750~1200	650~1000
250~ 350		T1500A	900~1350	800~1200	-	
		T1500Z	900~1450	800~1300	-	
		AC805P	900~1350	800~1200	700~1100	
		AC810P	900~1200	800~1100	700~1000	
		AC8025P	600~1000	500~900	450~900	
		AC820P	800~1000	700~900	650~900	
		AC830P	-	700~900	650~900	
Chipbreaker Preference		ESE/ESU/ELU	EGE/ELU	EME/EMU		

Technical Guidance



Recommended first choice,

Recommended second choice,

Recommended third choice

Work Material	Hardness	Grade	Machining Parameters			
			Finishing .002 ~ .012 IPR .005" ~ .060" D.O.C.	Gen. Purpose .010 ~ .020 IPR .040" ~ .200" D.O.C.	Roughing .015 ~ .026 IPR 200" D.O.C.	
CUTTING SPEED SFM						
MEDIUM CARBON STEELS 1030, 1033, 1035, 1037, 1038, 1039, 1040, 1042, 1043, 1044, 1045, 1046, 1049, 1050, 1053, 1055, 1132, 1137, 1139, 1140, 1141, 1144, 1145, 1146, 1151, 1524, 1525, 1526, 1527, 1536, 1541, 1547, 1548, 1551, 1552	<250	T1500A	900~1450	900~1300	-	
		T1500Z	900~1550	900~1450	-	
		AC805P	900~1450	900~1300	800~1100	
		AC810P	900~1300	900~1200	800~1000	
		AC8025P	600~1000	350~900	350~800	
		AC820P	800~1000	500~900	450~800	
		AC830P	-	500~800	400~700	
	220~350	T1500A	800~1300	700~1200	-	
		T1500Z	800~1450	700~1300	-	
		AC805P	800~1300	700~1200	600~1100	
		AC810P	800~1200	700~1100	600~1000	
		AC8025P	400~1000	350~900	350~900	
		AC820P	600~1000	500~900	450~900	
		AC830P	-	500~850	400~800	
	HRc 35~55	T1500A	600~1000	400~900	-	
		T1500Z	600~1100	400~1000	-	
		AC805P	500~1000	400~800	350~800	
		AC810P	500~900	400~750	350~700	
		AC8025P	350~750	300~700	300~550	
		AC820P	400~750	350~700	300~550	
		AC830P	-	350~600	300~500	
	MEDIUM HIGH CARBON STEELS --LEADED 41L30, 41L40, 41L45, 41L47, 41L50, 43L40, 41L50, 43640, 51L32, 52L100, 86L20, 86L40	<250	T1500A	800~1550	800~1450	-
			T1500Z	800~1650	800~1550	-
			AC805P	800~1550	800~1450	700~1200
AC810P			800~1400	800~1300	700~1100	
AC8025P			600~1200	500~1000	400~900	
AC820P			800~1200	700~1000	600~900	
AC830P			-	650~950	550~800	
250~ 350		T1500A	800~1450	750~1300	-	
		T1500Z	800~1550	750~1450	-	
		AC805P	800~1450	750~1300	650~1100	
		AC810P	800~1300	750~1200	650~1000	
		AC8025P	500~1100	450~1000	400~900	
		AC820P	700~1100	650~1000	550~900	
		AC830P	-	600~1000	500~800	
Chipbreaker Preference		ESE/ESU/ELU	EGE/ELU	EME/EMU		



Recommended first choice, Recommended second choice, Recommended third choice

Work Material	Hardness	Grade	Machining Parameters		
			Finishing .002 ~ .012 IPR .005" ~ .060" D.O.C.	Gen. Purpose .010 ~ .020 IPR .040" ~ .200" D.O.C.	Roughing .015 ~ .026 IPR 200" D.O.C.
			CUTTING SPEED SFM		
ALLOY STEELS– MEDIUM CARBON 1340, 1345, 4042, 4047, 4140, 4142, 4145, 4147, 4340, 50B40, 40B44, 5046, 50B46, 5140, 5145, 5147, 81B45, 8640, 8642, 8645, 86B45, 8740, 8742, 4150, 4161, 50B50, 4060, 50B60, 5150, 5155, 5160, 51B60, 6150, 8650, 8655, 8660, 9254, 9255, 9260	250~350	T1500A	700~1200	700~1100	–
		T1500Z	700~1300	700~1200	–
		AC805P	700~1200	700~1100	500~900
		AC810P	700~1100	700~1000	500~800
		AC8025P	350~950	350~850	350~800
		AC820P	600~950	500~850	450~800
		AC830P	–	500~800	400~700
	<250	T1500A	600~1100	600~1000	–
		T1500Z	600~1200	600~1100	–
		AC805P	600~1100	600~1000	–
		AC810P	600~1000	600~900	–
		AC8025P	350~900	350~800	350~750
		AC820P	500~900	450~800	400~750
		AC830P	–	400~750	300~700
	250~350	T1500A	300~650	300~550	–
		T1500Z	300~800	300~650	–
		AC805P	300~650	300~550	200~550
		AC810P	300~600	300~500	200~500
		AC8025P	250~500	200~450	150~400
		AC820P	250~500	200~450	150~400
		AC830P	250~400	200~400	150~400
HIGH CARBON STEELS 50100, 51100 52100, M-50	<250	T1500A	800~1300	700~1200	–
		T1500Z	800~1450	700~1300	–
		AC805P	800~1400	700~1300	600~1100
		AC810P	800~1250	700~1150	600~1000
		AC8025P	350~850	250~750	250~700
		AC820P	450~850	300~750	300~700
		AC830P	–	300~750	300~650
	250~350	T1500A	700~1200	600~1100	–
		T1500Z	700~1300	600~1200	–
		AC805P	700~1300	600~1200	500~900
		AC810P	700~1150	600~1100	500~800
		AC8025P	350~550	350~750	350~650
		AC820P	550~850	500~750	400~650
		AC830P	–	450~700	400~600
	Chipbreaker Preference	ESE/ESU/ELU	EGE/ELU	EME/EMU	

Technical Guidance



Recommended first choice, Recommended second choice, Recommended third choice

Work Material	Hardness	Grade	Machining Parameters		
			Finishing .002 ~ .012 IPR .005" ~ .060" D.O.C.	Gen. Purpose .010 ~ .020 IPR .040" ~ .200" D.O.C.	Roughing .015 ~ .026 IPR 200" D.O.C.
			CUTTING SPEED SFM		
TOOL STEELS DIE STEELS	<250	T1500A	500~800	350~800	-
		T1500Z	500~950	350~900	-
		AC805P	500~1000	350~900	300~850
		AC810P	500~900	350~800	300~750
		AC8025P	350~700	300~650	250~600
		AC820P	400~700	350~650	300~600
		AC830P	-	350~650	300~600
	250~350	T1500A	650~1000	450~950	-
		T1500Z	500~900	350~900	-
		AC805P	500~1000	450~900	350~850
		AC810P	500~900	450~800	350~750
		AC8025P	300~750	300~650	200~600
		AC820P	400~750	400~650	300~600
		AC830P	-	300~650	200~600
	HRc 36-50	T1500A	350~550	300~550	-
		T1500Z	300~600	200~550	-
		AC805P	300~650	200~550	200~550
		AC810P	300~600	200~500	200~500
		AC8025P	150~400	150~350	150~300
		AC820P	200~400	200~350	150~300
		AC830P	200~400	200~350	150~300
HIGH STRENGTH STEELS 300M, 4340, 4340M 4340V, H13, H11 50100, 51100 52100, M-50	250~300	T1500A	600~1000	450~900	-
		T1500Z	550~1050	450~950	-
		AC805P	500~1050	350~950	300~800
		AC810P	500~950	350~850	300~700
		AC8025P	300~700	250~700	200~650
		AC820P	400~700	350~700	300~650
		AC830P	-	350~700	300~600
	HRc 35-45	T1500A	550~900	350~850	-
		T1500Z	500~1000	350~950	-
		AC805P	500~1000	350~950	300~900
		AC810P	500~900	350~850	300~800
		AC8025P	300~800	200~700	200~650
		AC820P	400~800	300~700	250~650
		AC830P	-	300~650	250~600
Chipbreaker Preference		ESE/ESU/ELU	EGE/ELU	EME/EMU	



Recommended first choice,

Recommended second choice,

Recommended third choice

Work Material	Hardness	Grade	Machining Parameters		
			Finishing .002 ~ .012 IPR .005" ~ .060" D.O.C.	Gen. Purpose .010 ~ .020 IPR .040" ~ .200" D.O.C.	Roughing .015 ~ .026 IPR 200" D.O.C.
			CUTTING SPEED SFM		
STAINLES STEEL 300 SERIES AUSTENITIC	160~280	T1500A	350~850	300~650	-
		T1500Z	300~900	300~800	-
		AC510U	400~700	400~650	-
		AC520U	300~550	300~550	300~550
		AC530U	300~500	250~500	250~500
		EH510	300~500	300~500	-
		EH520	-	300~500	300~500
		AC810P	450~750	400~700	-
		AC820P	-	300~600	300~550
		AC830P	-	250~600	200~550
		AC610M	600~800	500~700	400~600
		AC6020M	350~750	300~700	300~650
		AC6030M	350~800	300~750	300~700
		AC630M	400~650	300~550	300~500
AC6040M	350~750	300~700	300~700		
STAINLESS STEEL 400 SERIES MARTENSITIC	160~260	T1500A	300~850	300~750	-
		T1500Z	300~950	300~850	-
		AC510U	500~850	450~750	-
		AC520U	400~700	400~600	300~600
		AC530U	300~600	300~550	300~550
		EH510	300~600	300~550	-
		EH520	300~600	300~550	300~500
		AC810P	-	400~700	-
		AC820P	450~650	300~600	300~550
		AC830P	-	250~600	200~550
		AC610M	500~700	500~650	500~600
		AC6020M	350~750	300~700	300~650
		AC6030M	400~750	400~700	400~650
		AC630M	300~650	300~600	300~550
AC6040M	350~700	250~650	250~600		
	Chipbreaker Preference	EEF/ESU	EEG/EEX/EUP	EEG/EMU	



Recommended first choice,

Recommended second choice,

Recommended third choice

Work Material	Hardness	Grade	Machining Parameters		
			Finishing .002 ~ .010 IPR .005" ~ .060" D.O.C.	Gen. Purpose .008 ~ .016 IPR .040" ~ .150" D.O.C.	Roughing .010 ~ .020 IPR 120~250" D.O.C.
CUTTING SPEED SFM					
STAINLESS STEEL 400 SERIES MARTENSITIC cont.	260~380	T1500A	200~600	200~550	-
		T1500Z	200~700	200~650	-
		AC510U	400~700	400~650	-
		AC520U	300~600	300~600	300~550
		AC530U	300~550	300~500	300~500
		EH510	300~600	300~600	-
		EH520	-	300~550	250~500
		AC810P	350~800	250~750	-
		AC820P	-	200~600	200~600
		AC830P	-	200~600	200~600
		AC610M	500~700	500~650	500~600
		AC6020M	400~700	400~650	400~600
		AC6030M	400~750	400~700	400~650
		AC630M	300~650	300~600	300~550
	AC6040M	250~700	250~650	250~600	
	HrC 36~46	T1500A	200~600	200~500	-
		T1500Z	200~700	200~650	-
		AC510U	300~650	250~600	-
		AC520U	300~600	250~550	250~550
		AC530U	250~550	250~500	250~500
		EH510	200~500	200~450	-
		EH520	-	200~450	200~400
		AC810P	200~750	200~700	-
		AC820P	-	200~550	200~500
		AC830P	-	200~550	200~500
		AC610M	400~700	400~650	400~600
		AC6020M	400~700	400~650	400~600
		AC6030M	200~700	200~650	200~600
		AC630M	200~650	200~600	200~550
	AC6040M	200~650	200~650	200~600	
Chipbreaker Preference		EEF/ESU	EEG/EEX/EUP	EEG/EMU	



Recommended first choice, Recommended second choice, Recommended third choice

Work Material	Hardness	Grade	Machining Parameters		
			Finishing .002 ~ .010 IPR .005" ~ .060" D.O.C.	Gen. Purpose .008 ~ .016 IPR .040" ~ .150" D.O.C.	Roughing .010 ~ .020 IPR 120~250" D.O.C.
			CUTTING SPEED SFM		
STAINLESS STEEL PRECIPITATION HARDENING 15-5PH, 16-6PH, 17-4, 17-7PH, 13-8Mo	160~260	T1500A	300~800	250~700	-
		T1500Z	300~900	250~750	-
		AC510U	400~900	350~850	-
		AC520U	400~800	400~750	400~700
		AC530U	300~600	300~550	300~500
		EH510	350~700	325~600	-
		EH520	-	300~650	250~550
		AC810P	400~900	400~800	-
		AC820P	300~750	300~650	300~600
		AC830P	-	300~650	300~600
		AC610M	400~700	400~650	400~600
		AC6020M	200~700	200~650	200~600
		AC6030M	200~750	200~700	200~600
		AC630M	200~650	200~600	200~550
	AC6040M	200~750	200~700	200~600	
	25~36	T1500A	200~700	200~600	-
		T1500Z	300~800	300~750	-
		AC510U	300~850	300~750	-
		AC520U	300~750	300~700	300~600
		AC530U	250~600	250~550	250~500
		EH510	250~450	250~400	-
		EH520	-	250~450	250~425
		AC810P	300~800	250~750	-
		AC820P	300~600	200~600	200~550
		AC830P	-	200~600	200~500
		AC610M	500~700	500~650	500~600
		AC6020M	200~700	200~650	200~600
		AC6030M	250~700	200~650	200~600
		AC630M	300~650	300~600	300~550
	AC6040M	250~700	200~650	200~600	
	36~46	T1500A	300~650	300~600	-
		T1500Z	300~700	300~650	-
		AC510U	300~650	300~650	-
		AC520U	300~650	300~625	250~600
		AC530U	250~550	250~500	250~500
		AC810P	200~750	200~650	-
AC820P		200~550	200~525	200~500	
AC830P		-	200~500	200~450	
AC610M		400~700	400~650	400~600	
AC6020M		200~700	200~650	200~600	
AC6030M		200~700	200~650	200~600	
AC630M		300~650	300~600	300~550	
AC6040M	200~700	200~650	200~600		
Chipbreaker Preference			EEF/ESU	EEG/EEX/EUP	EEG/EMU

Technical
Guidance



Recommended first choice,

Recommended second choice,

Recommended third choice

Work Material	Hardness	Grade	Machining Parameters		
			Finishing .002 ~ .010 IPR .005" ~ .060" D.O.C.	Gen. Purpose .008 ~ .016 IPR .040" ~ .150" D.O.C.	Roughing .010 ~ .020 IPR 120~250" D.O.C.
			CUTTING SPEED SFM		
STAINLESS STEEL WROUGHT AUSTENITIC	160~260	T1500A	200~600	200~550	-
		T1500Z	200~700	200~650	-
		EH510/520	250~600	200~500	150~400
		AC510U	200~750	200~750	300~700
		AC520U	200~750	200~700	200~700
		AC530U	200~600	200~550	200~500
		AC810P	300~850	250~750	250~750
		AC820P	300~600	200~600	200~600
		AC830P	300~700	200~600	300~600
		EH510/520	50~150	30~130	30~100
HIGH TEMP. ALLOYS Nickel Base, Wrought Haynes Alloy 263, Incoloy Alloy 901, 903 Inconel Alloy 617, 625, 702, 706, 718, 721, 722, X-750, 751, M252 Nimonic 75, 80 Waspaloy	25~36	AC510U	100~240	100~200	60~180
		AC520U	100~200	80~180	50~150
		AC530U	80~180	80~150	50~120
		WX2000	400~1500	400~1200	400~1000
		EH510/520	40~130	30~110	30~90
		AC510U	90~200	80~180	80~150
		AC520U	90~180	70~150	50~120
		AC530U	80~160	70~140	50~120
		WX2000	400~1500	400~1200	400~1000
		EH510/520	100~190	80~150	70~130
Nickel Base, Wrought Hastelloy Alloy		AC510U	120~230	90~190	80~170
		AC520U	120~230	90~190	80~170
		AC530U	80~180	80~150	50~150
		WX2000	400~1500	400~1200	400~1000
		EH510/520	60~140	50~130	40~110
Nickel Base, Wrought Incoloy Alloy 804, 825 Inconel Alloy 600, 601 Refractaloy 26	36~46	AC510U	80~180	60~150	50~140
		AC520U	80~180	60~150	50~140
		AC530U	70~150	50~140	50~120
		WX2000	400~1500	400~1200	400~1000
		EH510/520	60~130	40~120	30~100
Nickel Base, Cast Hastalloy Alloy		AC510U	70~200	50~180	40~150
		AC520U	70~170	50~150	40~130
		AC530U	60~150	50~130	40~120
		WX2000	400~1500	400~1200	400~1000
		Chipbreaker Preference	EEF/ESU	EEG/EEX/EUP	EEG/EMU



Recommended first choice,

Recommended second choice,

Recommended third choice

Work Material	Hardness	Grade	Machining Parameters		
			Finishing .002 ~ .010 IPR .005" ~ .060" D.O.C.	Gen. Purpose .008 ~ .016 IPR .040" ~ .150" D.O.C.	Roughing .010 ~ .020 IPR 120~250" D.O.C.
			CUTTING SPEED SFM		
HIGH TEMP ALLOYS IRON BASE, WROUGHT	180~230	AC510U	120~220	100~200	80~180
		AC520U	120~220	100~200	80~180
		AC530U	80~150	80~120	70~100
		WX2000	400~1500	400~1200	400~1000
	250~320	AC510U	120~210	90~190	75~160
		AC520U	120~210	90~190	75~160
		AC530U	80~180	80~160	50~120
		WX2000	400~1500	400~1200	400~1000
COBALT BASE		AC510U	110~210	100~180	80~160
		AC520U	110~210	100~180	80~160
		AC530U	80~180	70~150	50~120
		WX2000	400~1500	400~1200	400~1000
STELLITE		AC510U	110~200	100~170	80~150
		AC520U	110~200	100~170	80~150
		AC530U	80~180	80~150	50~120
		WX2000	300~1500	300~1200	300~1000
PURE TITANIUM		AC510U	100~190	90~170	80~140
		AC520U	100~190	90~170	80~140
		AC530U	80~150	70~130	50~120
TITANIUM ALLOY Ti-6AL-4V		EH510/520	100~180	90~160	70~140
		AC510U	120~210	120~190	100~160
		AC520U	120~210	120~190	100~160
		AC530U	80~170	70~150	50~120
ALUMINUM ALLOYS BRASS ALLOYS		DA1000*	1000~10000	1000~10000	-
		DA2200*	1000~10000	1000~10000	-
		DA150*	1000~10000	1000~10000	-
		H1	500~2000	500~2000	500~2000
		EH510/520	800~1700	700~1200	700~1000
		AC510U	500~1500	500~1200	500~1000
		AC520U	500~1500	500~1200	500~1000
		G10E	800~1500	700~1200	700~1000
	Chipbreaker Preference		EEF/ESU	EEG/EEX/EUP	EEG/EMU

* Refer to the PCD section for proper running conditions of PCD grades.



Recommended first choice,

Recommended second choice,

Recommended third choice

Work Material	Hardness	Grade	Machining Parameters		
			Finishing .002 ~ .012 IPR .005" ~ .100" D.O.C.	Gen. Purpose .008 ~ .020 IPR .040" ~ .120" D.O.C.	Roughing .015 ~ .030 IPR .100" ~ .180" D.O.C.
			CUTTING SPEED SFM		
COPPER ALLOYS WROUGHT 145, 147, 173, 187, 191, 314, 316, 330, 332, 335, 340, 342, 349, 350, 353, 356, 360, 365, 366, 367, 368, 370, 377, 385, 482, 485, 544, 623, 624, 638, 642, 782		DA1000*	2000~3300	2000~3300	-
		DA2200*	2000~3300	2000~3300	
		DA150*	2000~3300	2000~3300	-
		H1	500~2000	500~2000	500~2000
		EH510/520	800~1300	800~1200	700~1100
		AC510U	1200~1700	1100~1500	900~1300
		AC520U	1200~1700	1100~1500	900~1300
		G10E	800~1100	800~1000	700~900
190, 226, 230, 240, 260, 268,270, 280, 425, 435, 442, 443, 444, 445, 464, 465, 466, 467,613, 618, 630, 632, 651, 655, 667, 675, 687, 694, 770		DA1000*	2000~3300	2000~3300	-
		DA2200*	2000~3300	2000~3300	
		DA150*	2000~3300	2000~3300	-
		H1	500~2000	500~2000	500~2000
		EH510/520	800~1100	600~950	500~850
		AC510U	900~1300	800~1150	700~1000
		AC520U	900~1300	800~1150	700~1000
		G10E	800~900	600~750	500~650
411, 413, 505, 512, 511, 521, 524, 608, 610, 614, 619, 625, 674, 688, 706, 710, 715, 7285, 745		DA1000*	2000~3300	2000~3300	-
		DA2200*	2000~3300	2000~3300	
		DA150*	2000~3300	2000~3300	-
		H1	500~2000	500~2000	500~2000
		EH510/520	250~550	200~500	150~450
		AC510U	450~750	350~650	300~600
		AC520U	450~750	350~650	300~600
		G10E	250~350	200~300	150~250
	Chipbreaker Preference	EEF/ESU	EEG/EEEX/EUP	EEG/EMU	

* Refer to the PCD section for proper running conditions of PCD grades.



Recommended first choice, Recommended second choice, Recommended third choice

Work Material	Hardness	Grade	Machining Parameters		
			Finishing .002 ~ .010 IPR .005" ~ .060" D.O.C.	Gen. Purpose .008 ~ .016 IPR .040" ~ .150" D.O.C.	Roughing .010 ~ .020 IPR 120~250" D.O.C.
			CUTTING SPEED SFM		
COPPER ALLOYS, CAST 834, 836, 938, 842, 844, 848, 852, 8545, 8955, 857, 858, 864, 867, 879, 928, 932, 934, 935, 937, 938, 939, 943, 944, 945, 953, 954, 956, 973, 974, 976, 078		DA1000*	2000~3300	2000~3300	–
		DA2200*	2000~3300	2000~3300	
		DA150*	2000~3300	2000~3300	–
		EH510/520	1000~1400	850~1250	750~1150
		AC510U	1200~1600	1050~1500	950~1400
		AC520U	1200~1600	1050~1500	950~1400
		G10E	1000~1200	850~1050	750~950
817, 821, 833, 853, 861, 862, 865, 888, 872, 874, 875, 876, 878, 903, 905, 915, 9022, 923, 9059, 926, 927, 947, 948, 952, 955, 957, 958		DA1000*	2000~3300	2000~3300	–
		DA2200*	2000~3300	2000~3300	
		DA150*	2000~3300	2000~3300	–
		EH510/520	700~1100	550~850	500~800
		AC510U	950~1350	700~1100	650~1050
		AC520U	950~1350	700~1100	650~1050
		G10E	700~900	550~650	500~600
801, 803, 805, 807, 809, 811, 813, 814, 815, 818, 820, 822, 824, 825, 826, 827, 828, 863, 902, 907, 909, 910, 911, 913, 916, 917, 962, 963, 964, 966, 993		DA1000*	2000~3300	2000~3300	–
		DA2200*	2000~3300	2000~3300	
		DA150*	2000~3300	2000~3300	–
		EH510/520	300~600	175~500	150~450
		AC510U	500~850	350~725	325~675
		AC520U	500~850	325~725	325~675
		G10E	300~400	175~300	150~250
GRAY CAST IRON		BN500*	600~2400	–	–
		BN700*	2000~6000	–	–
		BNS800*	2000~6000	–	–
		SN2000K	1000~3500	800~3500	800~2500
		SN2100K	1000~3500	800~3500	800~2500
		T2000Z	600~1400	500~1200	–
		AC405K	700~1700	700~1500	600~1400
		AC410K	600~1600	500~1300	400~1000
		AC415K	600~1600	500~1300	400~1000
		AC420K	600~1500	500~1200	400~1000
		AC700G	–	400~1200	400~900
		AC820P	–	600~1000	500~900
		G10E	200~350	150~300	100~250
	Chipbreaker Preference		EEF/ESU	EEG/EEX/EUP	EEG/EMU

* Refer to the PCD section for proper running conditions of PCD grades.



Recommended first choice, Recommended second choice, Recommended third choice

Work Material	Hardness	Grade	Machining Parameters		
			Finishing .002 ~ .010 IPR .005" ~ .060" D.O.C.	Gen. Purpose .008 ~ .016 IPR .040" ~ .150" D.O.C.	Roughing .010 ~ .020 IPR 120~250" D.O.C.
			CUTTING SPEED SFM		
GRAY CAST IRON cont.	>220	BN500*	600~2000	-	-
		BN700*	1900~3100	-	-
		BNS800*	1900~3100	-	-
		SN2000K	1000~3500	800~3500	600~2500
		SN2100K	1000~3500	800~3500	600~2500
		T1500Z	500~1350	400~1100	-
		AC405K	600~1600	600~1500	600~1400
		AC410K	550~1600	500~1200	450~1000
		AC415K	550~1600	500~1200	450~1000
		AC420K	500~1500	450~1100	400~1000
		AC700G	-	300~1200	400~1000
		AC820P	-	600~1000	500~900
		G10E	200~300	150~300	100~250
DUCTILE IRON NODULAR IRON	<220	BN500*	300~1000	-	-
		T1500Z	350~1000	400~950	-
		SN2000K	600~1700	600~1500	500~1100
		SN2100K	600~1700	600~1500	500~1100
		AC405K	600~1700	600~1500	600~1400
		AC410K	500~1500	500~1200	400~1000
		AC415K	500~1500	500~1200	400~1000
		AC420K	500~1400	500~1100	400~1000
		AC700G	-	500~1100	400~1000
		AC820P	-	600~950	600~900
	>220	BN500*	300~900	-	-
		T1500Z	330~900	330~850	-
		SN2000K	500~1700	500~1500	400~1000
		SN2100K	500~1700	500~1500	400~1000
		AC405K	500~1700	500~1500	500~1100
		AC410K	400~1300	400~1100	300~1000
		AC415K	400~1300	400~1100	300~1000
		AC420K	400~1100	400~1000	300~900
		AC700G	-	400~900	300~800
		AC820P	-	500~900	450~850
AC510U	500~800	300~700	300~600		
Chipbreaker Preference		ENZ/FLAT TOP	EGZ/FLAT TOP	EGZ/ FLAT TOP	

Technical
Guidance

* Refer to the PCD section for proper running conditions of PCD grades.



① Wearing Process Curve

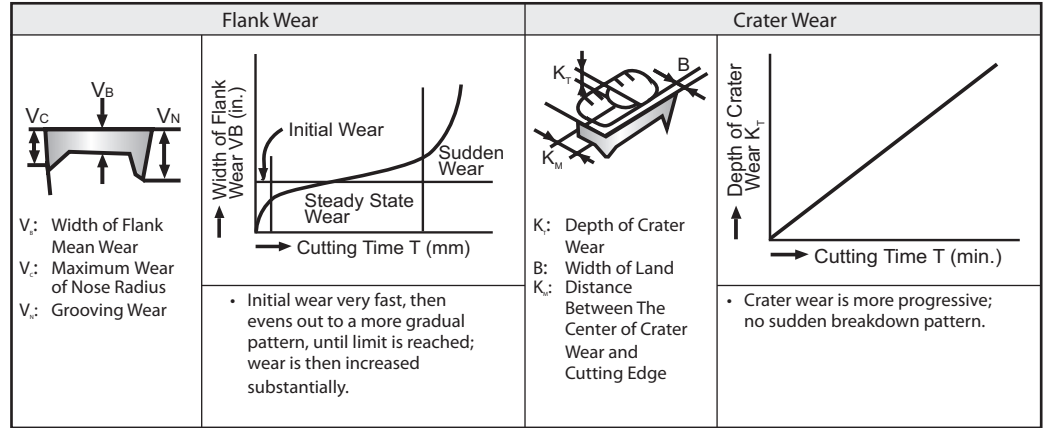

② Life Curve (V-T Lines)

At four speeds V_1, V_2, V_3 and V_4 , the relative tool lives for a given flank wear V , or crater K , are indicated as T_1, T_2, T_3 and T_4 respectively, using log-log graph paper.

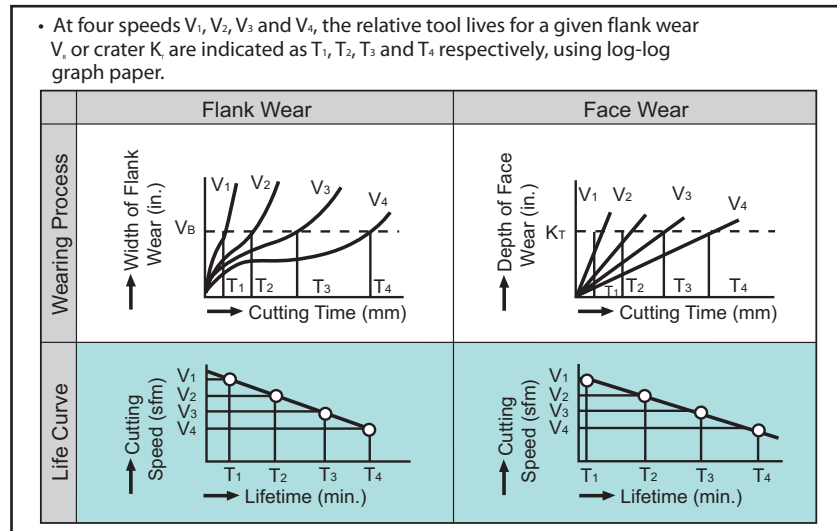

③ Tool Life Equation

Tool Life Equation (Taylor's Equation)

$$VT^n = C$$

V : Cutting Speed
 T : Tool Life
 n } Constants determined
 C } by work material, tool material, tool design, etc.

④ Alternative Tool Life Criteria

- When surface finish deteriorates unacceptably.
- When a fixed amount of tool wear is reached (see the right-hand table).
- When work piece dimension is out of tolerance.
- When power consumption reaches limit.
- Sparking or chip discoloration and disfigurement.
- Cutting time or component quantity.

Width of Flank Wear for General Life Determination (For Cemented Carbides)

Width of Wear (in.)	Applications
.008	Finish cutting of non-ferrous alloys, fine & light cut, etc.
.016	Cutting of special steels
.028	Normal cutting of cast irons, steels, etc.
.040-.050	Rough cutting of common cast irons

1. Forms of Tool Failure

	No.	Failure	Cause	
	1-5	Flank Wear	Physical	Due to the abrasive effect of hard grains contained in the work material
	6	Chipping		Fine chips caused by high-pressure cutting, chatter, vibration, etc.
	7	Partial Fracture		Due to the mechanical impact when an excessive force is applied to the cutting edge
	8	Crater Wear	Chemical	Carbide particles are removed due to degradation of tool performances and chemical reactions at high temperature
	9	Deformation		The cutting edge is deformed due to its softening at high temperature
10	Thermal Crack	Thermal fatigue in the heating and cooling cycle with interrupted cutting		
11	Build-Up Edge	A portion of the workpiece material adheres to the insert cutting edge		

2. Failure Remedies

	Failure	Basic Remedy	Proven Remedies									
Edge Failure	Excessive Flank Wear 	Tool Material Cutting Conditions <ul style="list-style-type: none"> • Use a more wear-resistant grade Carbide → { Coated Cermet • Decrease speed 	<ul style="list-style-type: none"> • Recommended Insert Grade: <table border="1"> <thead> <tr> <th></th> <th>Steel</th> <th>Cast Iron</th> </tr> </thead> <tbody> <tr> <td>Finishing</td> <td>AC810P</td> <td>BN700, BN7000, BNC500</td> </tr> <tr> <td>Rough</td> <td>ACA20P</td> <td>AC405K</td> </tr> </tbody> </table>		Steel	Cast Iron	Finishing	AC810P	BN700, BN7000, BNC500	Rough	ACA20P	AC405K
		Steel	Cast Iron									
	Finishing	AC810P	BN700, BN7000, BNC500									
	Rough	ACA20P	AC405K									
	Excessive Crater Wear 	Tool Material Tool Design Cutting Conditions <ul style="list-style-type: none"> • Use a crater-resistant grade Carbide → { Coated Cermet • Enlarge the rake angle • Select the correct chip breaker • Decrease speed • Reduce the depth of cut and feed 	<ul style="list-style-type: none"> • Recommended Insert Grade: <table border="1"> <thead> <tr> <th></th> <th>Steel</th> <th>Cast Iron</th> </tr> </thead> <tbody> <tr> <td>Finishing</td> <td>AC810P</td> <td>BN700, BN7000, BNC500</td> </tr> <tr> <td>Rough</td> <td>ACA20P AC830P</td> <td>AC415K, AC420K</td> </tr> </tbody> </table>		Steel	Cast Iron	Finishing	AC810P	BN700, BN7000, BNC500	Rough	ACA20P AC830P	AC415K, AC420K
		Steel	Cast Iron									
Finishing	AC810P	BN700, BN7000, BNC500										
Rough	ACA20P AC830P	AC415K, AC420K										
Cutting Edge Chipping 	Tool Material Tool Design Cutting Conditions <ul style="list-style-type: none"> • Use tougher grades If carbide, (AC820P → AC830P) • If built-up edge occurs, change to a less susceptible grade (cermet) • Reinforcement of the cutting edge (honing) • Reduce the rake angle • Increase speed (if caused by edge build-up) 	<ul style="list-style-type: none"> • Recommended Insert Grades: <table border="1"> <thead> <tr> <th></th> <th>Steel</th> <th>Cast Iron</th> </tr> </thead> <tbody> <tr> <td>Finishing</td> <td>T2000Z, T1200A</td> <td>BN700, BN7000, BNC500</td> </tr> <tr> <td>Rough</td> <td>ACA20P AC830P</td> <td>AC420K</td> </tr> </tbody> </table> <ul style="list-style-type: none"> • All coated inserts are honed 		Steel	Cast Iron	Finishing	T2000Z, T1200A	BN700, BN7000, BNC500	Rough	ACA20P AC830P	AC420K	
	Steel	Cast Iron										
Finishing	T2000Z, T1200A	BN700, BN7000, BNC500										
Rough	ACA20P AC830P	AC420K										
Partial Fracture of Cutting Edges 	Tool Material Tool Design Cutting Conditions <ul style="list-style-type: none"> • Use tougher grades If carbide, (AC820P → AC830P) • Use holder with a large approach angle • Use larger shank-size holder • Reduce the depth of cut and feed 	<ul style="list-style-type: none"> • Recommended Insert Grade: <table border="1"> <thead> <tr> <th></th> <th>Steel</th> <th>Cast Iron</th> </tr> </thead> <tbody> <tr> <td>Rough</td> <td>AC820P</td> <td rowspan="2">AC420K</td> </tr> <tr> <td>Machining</td> <td>AC830P</td> </tr> </tbody> </table>		Steel	Cast Iron	Rough	AC820P	AC420K	Machining	AC830P		
	Steel	Cast Iron										
Rough	AC820P	AC420K										
Machining	AC830P											
Built-up Edge 	Tool Material Cutting Conditions <ul style="list-style-type: none"> • Change to a grade which is adhesion resistant • Increase the cutting speed and feed • Use cutting fluids 	<ul style="list-style-type: none"> • Recommended Insert Grade: <table border="1"> <thead> <tr> <th></th> <th>Steel</th> <th>Cast Iron</th> </tr> </thead> <tbody> <tr> <td>Finishing</td> <td>T2000Z, T1200A</td> <td>BN700, BN500</td> </tr> <tr> <td>Rough</td> <td>AC820P</td> <td>AC700G, YB100</td> </tr> </tbody> </table>		Steel	Cast Iron	Finishing	T2000Z, T1200A	BN700, BN500	Rough	AC820P	AC700G, YB100	
	Steel	Cast Iron										
Finishing	T2000Z, T1200A	BN700, BN500										
Rough	AC820P	AC700G, YB100										
Plastic Deformation 	Tool Material Cutting Conditions <ul style="list-style-type: none"> • Change to high thermal resistant grades • Reduce the cutting speed and feed 	<table border="1"> <thead> <tr> <th></th> <th>Steel</th> <th>Cast Iron</th> </tr> </thead> <tbody> <tr> <td>Finishing</td> <td>T2000Z, AC810P</td> <td>AC405K</td> </tr> <tr> <td>Rough</td> <td>ACA20P</td> <td>AC415K, AC420K</td> </tr> </tbody> </table>		Steel	Cast Iron	Finishing	T2000Z, AC810P	AC405K	Rough	ACA20P	AC415K, AC420K	
	Steel	Cast Iron										
Finishing	T2000Z, AC810P	AC405K										
Rough	ACA20P	AC415K, AC420K										



■ Illustration of Technical Terms

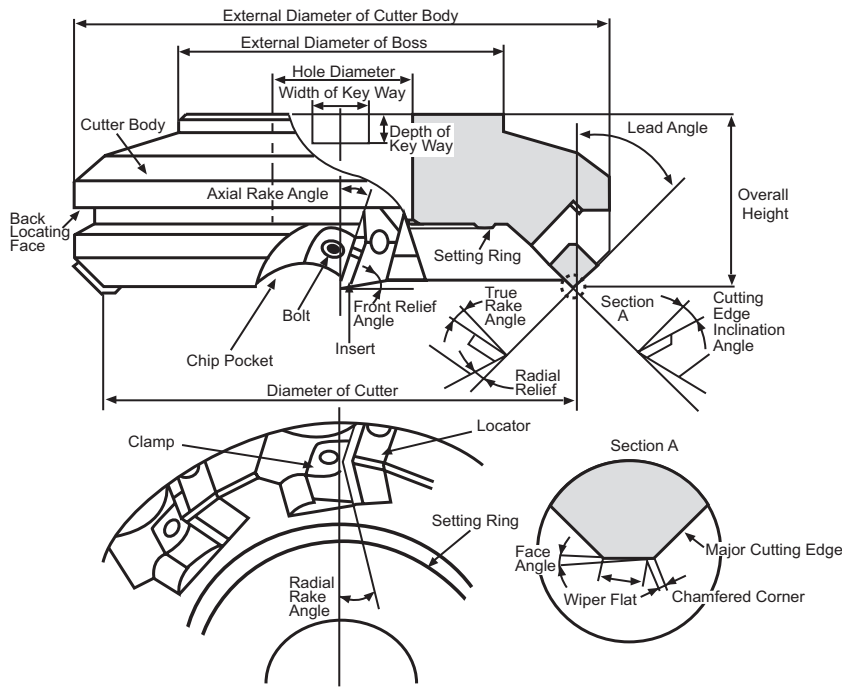

Calculating Power Requirement

• Power Requirement

$$P_c = \frac{a_e \times a_p \times v_f \times k_c}{60 \times 10^3 \times \eta} = \frac{Q \times k_c}{60 \times 10^3 \times \eta}$$

P_c : Power requirement (kw)
 H : Required horsepower (HP)
 Q : Chip removal amount (cm³/min)
 a_e : Cutting width (mm)
 v_f : Feed rate (mm/min)
 a_p : Depth of cut (mm)
 k_c : Specific cutting force (MPa)

• Horsepower Requirement

$$H = \frac{P_c}{0.75}$$

• Chip Removal Amount

$$Q = \frac{a_e \times a_p \times v_f}{1000}$$

Rough value $\left(\begin{array}{l} \text{Steel: 2,500 to 3,000MPa} \\ \text{Cast iron: 1,500MPa} \\ \text{Aluminium: 800MPa} \end{array} \right)$
 η : Machine efficiency (about 0.75)

• Relation Between Feed Rate, Work Material, Specific Cutting Force

Material	Alloy Steel	Carbon Steel	Cast Iron	Aluminum-Alloy
(1)	1.8	0.8	200	-
(2)	1.4	0.6	160	-
(3)	1.0	0.4	120	-

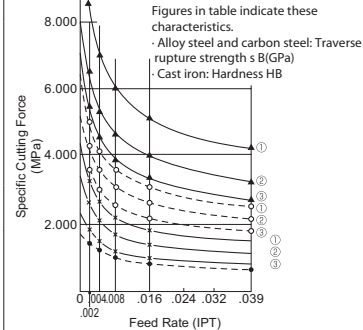

Cutting Force Comparison of Typical Sumitomo Mills

Cutter Series	Cutting Edge Angle (deg)			Cutting Force (MPa)			
	A.R	R.R	A.A	0	0.5	1.0	1.5
UFO	+27°	-7°	45°	Back force	Feed force	Principal force	Total force
FPG	+15°	-4°	45°				
DPG	+8°	-0°	15°				

• Work: 4137 (250HB)
 • Machine: M/C (15HP)
 • Cutting Conditions: $v_c=394$ SFM
 $f_z=0.012$ IPT
 $a_p=0.118$ "

• Calculating Cutting Speed

$$v_c = \frac{\pi \times D_c \times n}{1,000}$$

$$n = \frac{1,000 \times v_c}{\pi \times D_c}$$

• Calculating Feed Rate

$$v_f = f_z \times z \times n$$

$$f_z = \frac{v_f}{z \times n}$$

v_c : Cutting speed (SFM)
 $\pi \approx 3.14$
 D_c : Cutter diameter (inch)
 n : Rotational speed (min⁻¹)
 v_f : Feed rate per minute (IPM)
 f_z : Feed rate per tooth (IPT)
 z : Number of teeth
 f : Feed rate (IPR)

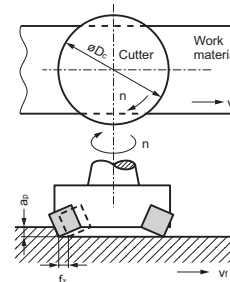

The following pages contain basic technical data intended to address the use and application of Sumitomo solid carbide, and indexable carbide tooling. Sumitomo has compiled speed, feed, horsepower, material, and grade information in order to help the machinist, programmer, tooling engineer, etc., obtain successful results with our products.

Often feedback is received in regards to Sumitomo's technical information. Customers inquire as to why this information may not yield the best possible results for their respective applications. The following is an explanation on the preferred way to utilize this section.

Perhaps milling, more so than most machining operations, brings forth a greater number of variables to the science of optimizing a successful machining operation. Tool grade, pitch, diameter, effective rake angle, work piece material, hardness,

rigidity, machine condition and design all will effect running parameters and overall tool performance. It is therefore not a question of looking up a number in a chart to maximize productivity, but to use the data provided to help customize the running parameters for a particular application.

One of the most valuable keys to ensuring productivity is an experienced machinist. The skill of an accomplished journeyman has yet to be replaced by any computer.

Take the time to check horsepower consumption, speeds, feeds and grade selection before loading a tool into the spindle and pressing "cycle start". Once an operation is completed successfully, then maximum productivity can be addressed.

■ MILLING APPLICATIONS

Work Material	Steels and Stainless Steels						Cast Iron and Non-Ferrous Metals			High Temperature Alloys				
	High Speed	Finishing		Medium	Roughing		High Speed	Finishing	Medium Cutting	Finishing	Medium	Roughing		
ISO/ANSI		P01/C8	P10/C7	P20/C6	P30/CSA	P40/C5		K01	K10	K20	K01/C4	K10/C3	K20/C2	
CBN							BN700							
							BNS800							
							BN500							
Ceramic							SN2100K							
Coated Cermet		T250A												
Coated Carbide		AC230					DL1000				ACM100			
		ACP100					ACK100							
			AC325				AC211				ACM200			
			ACP200				ACK200							
			ACZ310				EH520Z							
			ACZ330				ACK300							
			ACP300				ACZ310				ACM300			
			ACZ350											
	Uncoated Carbide				A30N			H1		G10E				
					S30E					EH20				
									EH520					



1. Coated Grades

Grade	Coating Layer	Applications	Color	Old Grade
ACP100	CVD "Super FF" Coating	General to high speed and wet cutting of steels and stainless steels	Gold	AC230
ACP200	PVD "Super ZX" Coating	First choice for general purpose milling of steels and stainless steels	Bronze	ACZ330
ACP300	PVD "Super ZX" Coating	Very tough grade for steels and stainless steels	Bronze	ACZ350
ACK100	CVD "Super FF" Coating	High speed grade for milling gray and ductile cast irons	Gold	
ACK200	CVD "Super FF" Coating	General purpose milling of gray and ductile cast irons	Gold	AC211
ACK300	PVD "Super ZX" Coating	General to heavy cutting of gray and ductile cast irons	Bronze	ACZ310
ACM100	PVD "Super ZX" Coating	For finishing applications of stainless steels and exotics	Bronze	
ACM200	CVD "Super FF" Coating	First choice for general purpose milling of stainless steels and exotics	Gold	AC325
ACM300	PVD "Super ZX" Coating	Tough grade for interrupted machining of stainless steels and exotics	Bronze	
AC325	Double Phase PVD	General purpose milling of steels and stainless steels	Gold	
AC230	Multi-Phase Al ₂ O ₃	High speed milling of steels and stainless steels	Gold	
AC211	Multi-Phase Al ₂ O ₃	General purpose milling of cast iron	Gold	
ACZ120	ZX Coating (TIN/AIN)	Finish milling of heat treated tool steels and alloys	Pink	
ACZ310	ZX Coating (TIN/AIN)	General purpose milling of cast iron	Pink	
ACZ330	ZX Coating (TIN/AIN)	General purpose milling of steels and stainless steels	Pink	
ACZ350	ZX Coating (TIN/AIN)	General purpose milling of steels and stainless steels	Pink	
DL1000	Diamond-Like Carbon	High speed milling of non-ferrous materials	Blue	

2. Cermet Grades

Grade	Hardness (Hv)	T.R.S. (kg/mm ²)	Applications
T250A	1430	220	Finish milling of steels and stainless steels
T2500A	1430	220	Finish milling of steels and stainless steels

3. Ceramic Grades

Grade	Composition	Hardness (Hv)	Applications
SN2100K	Si ₃ N ₄	1,600	Milling of cast iron

4. CBN

Grade	Hardness (Hv)	Applications
BN500	3,300-3,500	High speed milling of gray and nodular cast irons
BN700	4,100-4,400	High speed milling of cast iron and powdered metals
BNS800	4,000-4,300	High speed milling of gray cast iron

5. Polycrystalline Diamond (PCD)

Grade	Hardness (Hv)	Applications
DA2200	9,000-10,000	Finishing, roughing and interrupted machining of aluminum and non-ferrous materials
DA200	8,000-10,000	Milling of non-ferrous alloys and plastics
DA150	10,000-12,000	Machining of aluminum, copper, wood, rubber, graphite and carbide (soft), plastic, etc.

6. Uncoated Carbide

Grade	Grade	Hardness	T.R.S. (psi)	Applications
C-5A	S30E	91.3	348,000	Milling of steels and stainless steels
	A30N (A30)	90.6	354,000	Rough turning and milling of steel and stainless steel
C3	H1	92.4	352,000	Finishing to semi-finishing of aluminum
C2	G10E	91.0	280,000	Milling of cast iron and aluminum
	H10E	92.3	284,467	Wiper inserts for cast iron and aluminum
	EH20	91.0	474,000	Milling of exotic materials
	EH520	91.8	436,000	Longer tool life for exotic material milling



■ **Grade Descriptions/Applications**

Sumitomo Electric Carbide, Inc. continues to introduce new and improved grades for milling. The patented “Super ZX” and “Super FF” coatings are featured on our new ACK and ACP series grades. This technology provides our customers with increased tool life and productivity.

With the introduction of our Wave Ballnose Finishing Endmill (WBMF), Sumitomo developed a ZX coated grade ACZ120 dedicate. The ACZ120 excels in applications involving finish milling of heat treated tool steels and alloys, and is available only for the WBMF cutter.

Sumitomo’s idea of constant improvement through technology has once again provided the industry with a new style of insert. The Diamond-Like Carbon (DLC) coating on grade DL1000 excels in high speed non-ferrous milling applications due to its extremely hard coating.

These tools added to Sumitomo’s existing milling grades complete the product line, making it easier for the customer when dealing with difficult applications.

■ **Coated Grades**

Grade	Coating Layer	Applications	Color
ACP100	CVD “Super FF” Coating	General to high speed and wet cutting of steels and stainless steels	Gold
ACP200	PVD “Super ZX” Coating	First choice for general purpose milling of steels and stainless steels	Bronze
ACP300	PVD “Super ZX” Coating	Very tough grade for steels and stainless steels	Bronze
ACK100	CVD “Super FF” Coating	High speed grade for milling gray and ductile cast irons	Gold
ACK200	CVD “Super FF” Coating	General purpose milling of gray and ductile cast irons	Gold
ACK300	PVD “Super ZX” Coating	General to heavy cutting of gray and ductile cast irons	Bronze
ACM100	PVD “Super ZX” Coating	For finishing applications of stainless steels and exotics	Bronze
ACM200	CVD “Super FF” Coating	First choice for general purpose milling of stainless steels and exotics	Gold
ACM300	PVD “Super ZX” Coating	Tough grade for interrupted machining of stainless steels and exotics	Bronze
AC325	Double Phase PVD	General purpose milling of steels and stainless steels	Gold
AC230	Multi-Phase Al ₂ O ₃	High speed milling of steels and stainless steels	Gold
AC211	Multi-Phase Al ₂ O ₃	General purpose milling of cast iron	Gold
ACZ120	ZX Coating (TIN/AIN)	Finish milling of heat treated tool steels and alloys	Pink
ACZ310	ZX Coating (TIN/AIN)	General purpose milling of cast iron	Pink
ACZ330	ZX Coating (TIN/AIN)	General purpose milling of steels and stainless steels	Pink
ACZ350	ZX Coating (TIN/AIN)	General purpose milling of steels and stainless steels	Pink
DL1000	Diamond-Like Carbon	High speed milling of non-ferrous materials	Blue

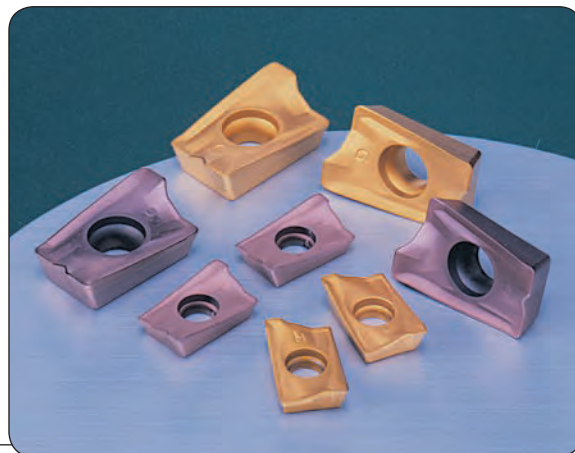

■ Cermet Grades

Grade	Hardness (Hv)	T.R.S. (kg/mm ²)	Applications
T250A	1430	220	Finish milling of steels and stainless steels
T4500A	1430	220	Finish milling of steels and stainless steels

Cermets are a type of cutting tool insert that combine the properties of ceramic and metal materials in their chemical makeup. These tools provide excellent surface finishes and have a high resistance to adhesion due to their sharp cutting edge.

Sumitomo T250A cermet milling grade exhibits excellent toughness in finish milling applications. Also, the T250A is a great economic alternative to coated carbide grades when machining steels and stainless steels.

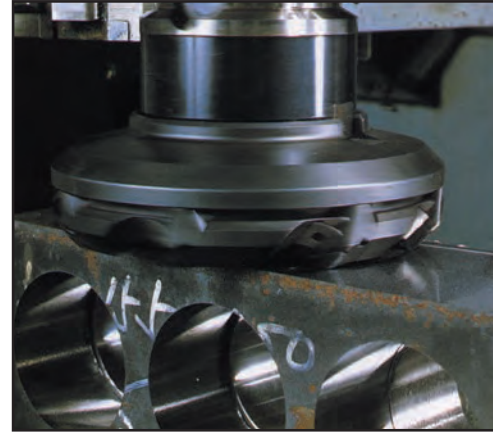

■ Ceramic Grades

Grade	Composition	Hardness (Hv)	Applications
SN2100K	Si ₃ N ₄	1,600	Milling of cast iron

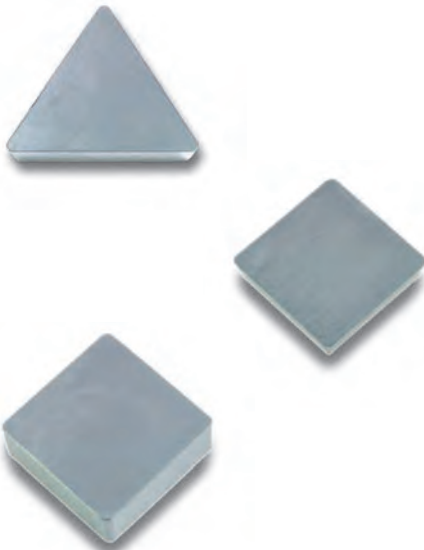

Developed using a patented microwave sintering process that produces a very fine-grained microstructure with enhanced characteristics, Sumitomo ceramic grade SN2100K is ideal for machining a cast iron materials.

■ GRADE FEATURES

Silicon Nitride Ceramic SN2100K

With its high shock and impact resistance, SN2100K is a grade ideally suited for cast iron roughing; use specifically when exceptional toughness and wear resistance is required..



■ Uncoated Carbide

Grade	Grade	Hardness	T.R.S. (psi)	Applications
C-5A	S30E	91.3	348,000	Milling of steels and stainless steels
	A30N (A30)	90.6	354,000	Rough turning and milling of steel and stainless steel
C3	H1	92.4	352,000	Finishing to semi-finishing of aluminum
C2	G10E	91.0	280,000	Milling of cast iron and aluminum
	H10E	92.3	284,467	Wiper inserts for cast iron and aluminum
	EH20	91.0	474,000	Milling of exotic materials
	EH520	91.8	436,000	Longer tool life for exotic material milling

Sumitomo Electric Carbide, Inc's research and development of tungsten carbide grades began in 1927. Since then, we have greatly improved and refined our grades to meet the needs of our customers today.

Our latest uncoated carbide milling grade is the EH520. This extremely tough grade outperforms the competition in applications involving exotic materials.



■ **Cubic Boron Nitride (CBN) Grades**

Grade	Hardness (Hv)	Applications
BN7000	4,100-4,400	High speed milling of gray and nodular cast irons
BN700	4,000-4,300	High speed milling of cast iron and powdered metals
BNS800	3,900-4,200	High speed milling of gray cast iron

Sumitomo Electric Carbide, Inc. is a world leader in the development of CBN cutting tool materials and their applications. For you, this means increased productivity, better surface finish, and an ability to hold closer tolerances with longer tool life. Sumitomo offers products, sizes and grades available nowhere else.

BN500, BN700, and BNS800 are three grades produced by Sumitomo and dedicated to machining cast irons. Their wear resistance and high speed capability increases tool life and productivity.

PCBN is generally classified into two groups according to the material microstructure. The CBN particles of the first type are bonded together directly without an additional binder material (BN700/BNS800). This type of CBN contains a large percentage of CBN and is thus extremely hard.

SUMIBORON, representative of the second type of PCBN materials, consists of CBN particles bonded together by a ceramic binder (BN500). The bonding strength is very high and thus is very wear-resistant and tough.

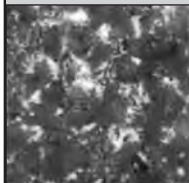
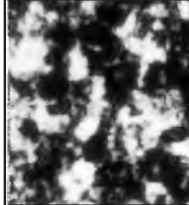
Microstructure	Features	Grades
	CBN particles are bonded to each other	BN700 BNS800
	CBN particles are bonded by a ceramic binder	BN500



Polycrystalline Diamond				
Grade	DA1000	DA2200	DA150	DA200
Average diamond crystal size (microns)	0.5	0.5	5	0.5
Hardness (Hv)	11,000-12,000	9,000-10,000	10,000-12,000	8,000-10,000
T.R.S. (kg/mm ²)	260	250	200	220
Product Description	<ul style="list-style-type: none"> • Ultra-fine grain structure • Superior hardness and wear resistance with sharp edge 	<ul style="list-style-type: none"> • High density sintered material made of ultra-micro diamond particles • Superior hardness and wear resistance with sharp edge 	<ul style="list-style-type: none"> • Fine grain diamond • High abrasion resistance 	<ul style="list-style-type: none"> • Ultra-fine grain structure • Superior tool edge sharpness and toughness
Applications	<ul style="list-style-type: none"> • High Silicon Aluminum • Copper • Fiberglass • Hard Rubber • Graphite Epoxy • Wood • Aluminum Alloys • Plastics • Carbon (finishing, roughing, interrupted) 	<ul style="list-style-type: none"> • High Silicon Aluminum • Copper • Fiberglass • Hard Rubber • Graphite Epoxy • Wood • Aluminum Alloys (finishing, roughing, interrupted) 	<ul style="list-style-type: none"> • High Silicon Aluminum • Copper • Fiberglass • Hard Rubber • Graphite Epoxy • Wood • Carbon 	<ul style="list-style-type: none"> • Wood • Plastics • Aluminum applications where low microfinish is needed

Since the introduction of SUMIDIA DA polycrystalline diamond (PCD) blanks in 1978, Sumitomo has continually developed and expanded the product line to offer finished inserts in a wide range of grades, shapes and sizes. SUMIDIA inserts consist of a layer of fine grain synthetic diamond crystals bonded to a tungsten carbide substrate which is securely brazed into the pocket of a standard size insert. A high degree of diamond to diamond bonding is achieved by an ultra high pressure-temperature process. This crystal to crystal bonding provides exceptional hardness and abrasion resistance.

Our closely controlled manufacturing process produces unequalled consistency resulting in superior tool edge quality. SUMIDIA DA inserts and wipers are replacing

tungsten carbide and natural diamond cutting tools on a worldwide basis. Use of SUMIDIA DA grades will provide dramatically increased tool life, the ability to hold closer part tolerance, and improved surface finish.

New technological advances have given the industry a new style of PCD insert. The optimum size of PCD used in NF-DA2200 offers a less expensive alternative when machining non-ferrous materials.



■ Illustration of Technical Terms

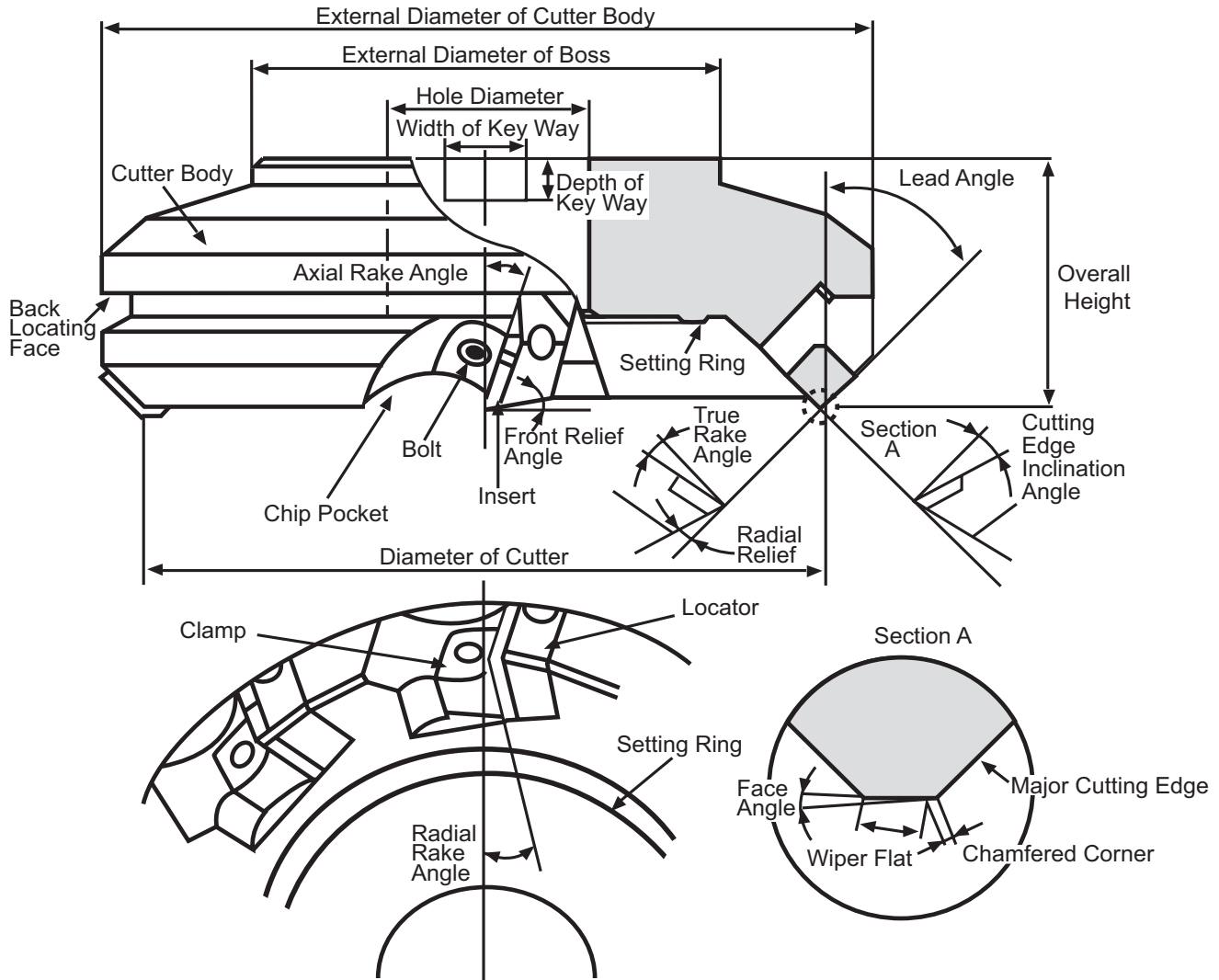

Technical Guidance



■ Horsepower Consumption

This section contains the horsepower consumption formula and the explanation of the associated variables. A list of commonly encountered materials has been added to assist you when determining the required horsepower for a machining operation.

Machine efficiency, drive type, and amount of time that the machine has been running can effect the horsepower and torque availability at the spindle. Without an extensive list of specifications, it is nearly impossible to predict the capabilities of a machine tool. Sumitomo suggests that unless the capabilities of a machine tool are well known, it is wise to limit the attempted operations to those that require no more than 65% of the machine's rated horsepower.

Please take the time to understand the power requirements of an operation before attempting it, unless you are very familiar with the tool, material, and especially the machine being used.

*Note: If the material that you are machining is not found in this list, contact the material manufacturer for further information. Most material suppliers, or mills, have excellent technical resources available. However, if the material in question exhibits machining properties that are similar to a given material, use the corresponding "K" factor.

■ Horsepower Consumption Formula

$$\text{Horsepower} = \frac{W \times D \times F}{K}$$

W = width of cut (inches)
D = depth of cut (inches)
F = feed rate (inches/minute)
K = 'K' factor for material

'K' factors for some common materials are:

Material	'K'
Magnesium	4.0
Aluminum	4.0
Copper	2.0
Brass	2.5
Bronze	2.0
Malleable iron	1.0
<u>Cast iron</u>	
Ferrite	1.5
Pearlitic	1.0
Chilled	.6
<u>Steel</u>	
up to 150 BHN	1.0
up to 300 BHN	.8
up to 400 BHN	.5
up to 500 BHN	.4

Material	'K'
<u>Stainless steel</u>	
Free machining	1.0
Others	.6
<u>Titanium</u>	
under 100,000 psi	.8
100,000-135,000 psi	.6
135,000 psi and over	.4
<u>High-tensile alloys</u>	
180,000-220,000 psi	.5
220,000-260,000 psi	.4
260,000-300,000 psi	.3
<u>High-temperature alloys</u>	
Nickel base alloys	.4
Cobalt base alloys	.4
Austenitic alloys	.4



■ COMMENTARY ON GENERAL MACHINING PRACTICES

Despite the influx of computers, Computer Aided Design and Computer Aided Machining in the modern manufacturing environment, general machining practices are almost unchanged from those used decades ago.

Correct set up of the work piece, tooling and machine are mandatory for high productivity, and more importantly, success. Sumitomo assumes that an enduser's shop practices are proper. Technology cannot replace sound machining practices.

In almost all situations where a CNC machine, or a conventional machine with backlash eliminators is used, modern carbide tooling should be applied with tool paths that climb mill. Conventional milling reduces tool life, promotes vibration and chatter, and prevents maximum performance in most situations.

INCORRECT

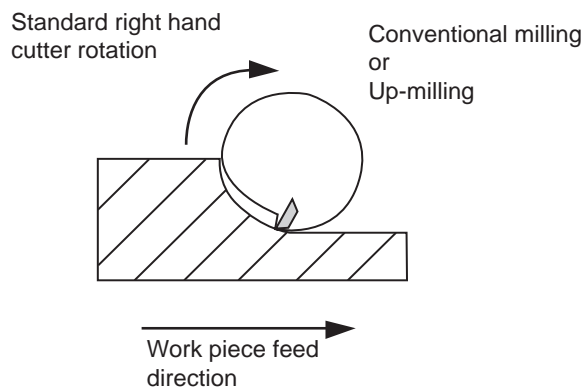

CORRECT!

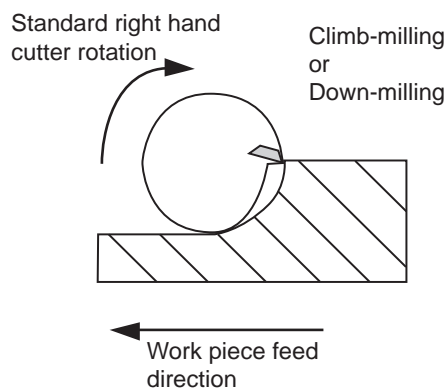

■ Lead Angle Effect

The lead angle effect is a commonly known phenomenon in tool design. As the lead angle of a tool (the angle at which the insert is rotated away from its axial center line) increases, the actual thickness of the produced chip decreases from the programmed amount. This allows us to take advantage of increased feed rates over standard zero degree (90 degree shoulder) lead tools.

By comparing the following lead angle figures, it is possible to increase the actual feed rate up to 30% over the suggested numbers (depending on the type of tool), thus increasing productivity.

Tool Lead Angle	Percentage of chip thickness from programmed feed rate
15 degrees	96%
20 degrees	94%
30 degrees	86%
45 degrees	71%

To simplify this calculation we have included a chart that allows easy determination of *programmed feed per tooth* by choosing *desired feed per tooth* and then following the column down to the row that matches the lead angle of the tool that is being used.

Example: Find the programmed feed per tooth for a UFO cutter (45 degree lead angle), when the desired feed per tooth is 0.006 IPT.

Answer: Programmed feed per tooth = 0.0085 IPT

Programmed Feed Per Tooth vs. Desired Feed Per Tooth

Tool Lead Angle	Desired Feed Per Tooth (IPT)								
	0.004	0.005	0.006	0.007	0.008	0.009	0.010	0.011	0.012
Programmed Feed Per Tooth (IPT)									
15	0.0042	0.0052	0.0063	0.0073	0.0083	0.0094	0.0104	0.0115	0.0125
20	0.0043	0.0053	0.0064	0.0074	0.0085	0.0096	0.0106	0.0117	0.0128
30	0.0047	0.0061	0.0070	0.0081	0.0093	0.0105	0.0116	0.0128	0.0140
45	0.0057	0.0075	0.0085	0.0099	0.0113	0.0127	0.0141	0.0156	0.0170



■ Radial Chip Thinning

Just as the axial rake of a cutting tool can alter the actual chip thickness, so can radial chip thinning. This occurs whenever the radial width of cut is less than 1/2 the cutter diameter. This is commonly found when making periphery cuts while end milling.

Since both tool life and productivity rely on maintaining full chip thickness, it is important to compensate for this scenario. Rather than using the mathematical process to arrive at a *programmed feed rate*, we have included the following chart.

To use this chart it is necessary to have the following information:

- 1) Desired feed per tooth (as taken from the end mill speed and feed section)
- 2) Cutter diameter
- 3) Radial width of cut

The first step is to divide the radial width of cut by the cutter diameter and find the closest value in the first column on the left. Next find the *desired feed per tooth* at the top of the chart and follow that column down to the row that was found in the first step. This will be the *programmed feed per tooth*.

Example: 1.00" diameter end mill Answer: Dividing 0.020" by 1.00"=0.020
 0.020" radial width of cut
 0.004" *desired feed per tooth*

Finding 0.020 in the first column on the left, and then the 0.004" desired feed per tooth at the top, we find where the two meet and obtain 0.014" *programmed feed per tooth*.

This results in a large increase in the feed rate. If we use these factors for a four flute tool at 2292 RPM, we have a feed rate of 128 IPM (2292 RPM x 0.014 IPT x 4 Flutes) versus 37 IPM (2292 RPM x 0.004 IPT x 4 Flutes) that might have otherwise been programmed.

As you can see from the illustration below, as radial depth increases, so does chip thickness until we reach 50% of the cutting diameter. At this point we have full, programmed chip load.

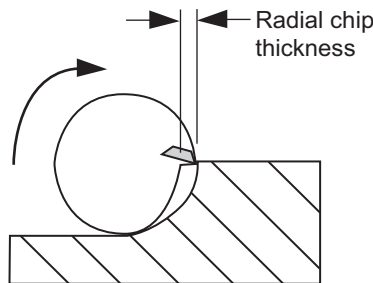

■ Radial Chip Thinning Compensation

Desired Feed Per Tooth (IPT)									
	0.004	0.005	0.006	0.007	0.008	0.009	0.010	0.011	0.012
WOC/Dia.	Programmed Feed Per Tooth (IPT)								
0.005	0.0280	0.0350	0.0420	0.0490	0.0560	0.0630	0.0700	0.0770	0.0840
0.010	0.0200	0.0250	0.0300	0.0350	0.0400	0.0450	0.0500	0.0550	0.0600
0.015	0.0164	0.0205	0.0246	0.0287	0.0328	0.0369	0.0410	0.0451	0.0492
0.020	0.0140	0.0175	0.0210	0.0245	0.0280	0.0315	0.0350	0.0385	0.0420
0.025	0.0128	0.0160	0.0192	0.0224	0.0256	0.0288	0.0320	0.0352	0.0384
0.030	0.0116	0.0145	0.0174	0.0203	0.0232	0.0261	0.0290	0.0319	0.0348
0.035	0.0108	0.0135	0.0162	0.0189	0.0216	0.0243	0.0270	0.0297	0.0324
0.040	0.0100	0.0125	0.0150	0.0175	0.0200	0.0225	0.0250	0.0275	0.0300
0.060	0.0084	0.0105	0.0126	0.0147	0.0168	0.0189	0.0210	0.0231	0.0252
0.080	0.0072	0.0090	0.0108	0.0126	0.0144	0.0162	0.0180	0.0198	0.0216
0.120	0.0060	0.0075	0.0090	0.0105	0.0120	0.0135	0.0150	0.0165	0.0180
0.200	0.0052	0.0065	0.0078	0.0091	0.0104	0.0117	0.0130	0.0143	0.0156
0.300	0.0044	0.0055	0.0066	0.0077	0.0088	0.0099	0.0110	0.0121	0.0132



■ **Indexable Milling Cutters**

The following chart contains a list of commonly encountered materials, suggested surface speeds, and chip loads (ipt). It is important to note that this is not a complete listing of all materials used in industry. It should be considered a guide to be used when initially setting up a new application, and as a resource for better understanding Sumitomo's cutting tool grades.

As there are tremendous variations in the capabilities and performance of machine tools, and variations in work piece materials as well, individual results can vary considerably. This is where the trained eye of an advanced machinist, or Applications Engineer can markedly improve tool life and productivity. Sumitomo has Sales and Applications personnel for just this purpose. When in doubt of the correct selection of a tool type or grade your sales person can assist in achieving winning results.

When applying carbide grades it is important to understand the characteristics of the different types that Sumitomo offers. A few minutes spent looking at the grade comparison chart on page 83 will shed some light on the differences between them. Coated grades in most situations will provide an increase in tool life, and are the preferred choice in the

majority of industry today. Whether coated or not, the harder grades will tend to be more wear resistant, but at the cost of toughness. They generally will be the best choice for easier to machine materials, but will sacrifice tool life in situations that lack machine and/or part rigidity.

When programming an operation with a new grade, or an unfamiliar material, it is wise to start at the low end of the speed and feed range and then work towards the upper ranges. Make any changes one at a time so that the results can be examined accurately.

It is worth noting that modern cutting tool materials will often encounter as many problems when run too slowly, or when programmed at insufficient feed rates as they can when run too fast. Since most of our inserts have been manufactured with edge preparations, feeds below .002, or .003 IPT may diminish tool life. Also, they must have enough speed to operate correctly. Cutting tools require an elevated temperature to perform without chip weld. Proper cutting parameters will insure the heat that is generated will be deposited into, and removed with the chip. Most situations involving steels and alloys the best results are obtained with an air blast versus coolant. In applications cutting exotic alloys, aluminum, brass, grey iron, etc., commonly employ coolant.

Technical
Guidance

Material	Hardness	Insert Grade				Speed SFM			Feed IPT
		Carbide	Cermet	Diamond	Ceramic	.002-.050	.050-.125	.125 and over	
Low and medium carbon steels 1008,1010,1018 1020,1025 etc.	~.250Bhn	ACP200				721-1213	675-1180	600-1125	.006-.0135
		ACP100				775-1310	725-1275	675-1225	.006-.0125
			T250A			700-1310	675-1200	575-1000	.0035-.0075
		ACP300				675-1075	650-1025	525-925	.006-.014
			T4500A			700-1450	675-1350	575-1100	.0035-.0075
Free machining steels and alloys Freemax 15 Freemax 45 12L14, etc.	~.250Bhn	ACP200				725-1300	700-1250	675-1200	.006-.0135
		ACP100				750-1325	725-1275	675-1225	.006-.0135
			T250A			825-1450	825-1375	775-1300	.0035-.0085
			T4500A			825-1600	825-1500	775-1450	.0035-.0085
		ACP300				675-1075	650-1050	650-1025	.006-.014
Medium-high carbon steels 1040,1045 1055,1080 50100,51100 52100,M-50	<.250 Bhn	ACP200				575-950	550-925	500-875	.006-.012
		ACP100				600-975	575-950	550-900	.006-.011
		ACP300				575-950	550-925	500-875	.006-.012
			T250A			450-950	425-850	400-825	.0035-.0075
			T4500A			450-1050	425-950	400-900	.0035-.0075

*NOTE: THESE SPEEDS ARE BASED ON 2/3 THE DIAMETER OF THE CUTTER ENGAGED.



SPEEDS & FEEDS

Material	Hardness	Insert Grade				Speed SFM			Feed IPT	
		Carbide	Cermet	Diamond	Ceramic	.002-.050	.050-.125	.125 and over		
Medium carbon alloy steels 4140, 4340 5130, 8620	>.250 Bhn	ACP200				550-900	525-900	500-875	.006-.0115	
		ACP100				600-875	575-950	550-900	.006-.0095	
		ACP300				525-875	500-825	475-800	.006-.0115	
			T250A			450-950	425-850	400-825	.0035-.0075	
			T4500A			450-1050	425-950	400-900	.0035-.0075	
Tool steels D2, H13, S7, etc.	<.250 Bhn	ACP200				450-820	435-790	425-750	.0047-.011	
		ACP300				450-820	425-790	400-725	.0047-.012	
		ACP100				475-820	450-790	425-750	.0047-.010	
			T250A			450-650	425-600	250-550	.0039-.0079	
			T4500A			450-750	425-650	250-600	.0039-.0079	
	Bhn 220-350	ACP200				400-750	375-725	375-690	.0045-.010	
		ACP300				375-700	400-695	375-685	.0047-.012	
		ACP100				425-775	400-735	400-700	.004-.009	
	>.35 Hrc	ACP200				325-650	300-625	300-590	.0045-.0095	
		ACP100				325-650	300-625	300-590	.003-.007	
	<55 Hrc	ACK300				175-400	150-350	125-300	.003-.008	
		ACP100				160-250	135-300	110-250	.003-.006	
	Martensitic and Ferritic stainless steels 414, 416, 430, 440		ACP300				300-740	275-825	250-800	.004-.012
			ACP200				325-875	300-850	275-825	.004-.011
		ACM200				500-600	400-500	400-500	.0035-.0075	
		ACM300				500-600	400-500	350-500	.004-.009	
			T250A			550-950	500-900		.0035-.0075	
	T4500A			550-1050	500-1000		.0035-.0075			
Austenitic and Pre-precipitation hardening stainless steels 303, 304, 316, 321, etc.		ACP300				300-850	275-825	250-800	.004-.012	
		ACP200				325-875	300-850	275-825	.004-.011	
		ACM200				350-600	325-550	300-500	.003-.008	
		ACM300				300-600	300-550	300-500	.003-.009	
			T250A			650-950	600-900		.0035-.0075	
			T4500A			650-1050	600-1000		.0035-.0075	
Titanium alloy		ACM300				100-300	100-275	100-250	.003-.008	
		ACK300				100-300	100-275	100-265	.003-.007	
Exotic alloys Inconel, Hastalloy Waspalloy, etc.		ACM300				100-300	100-250	100-225	.003-.008	
		ACK300				100-160	70-150	60-135	.003-.006	
		ACM200				100-300	100-250	100-225	.003-.006	
		G10E				70-125	60-110	50-100	.003-.007	



Material	Hardness	Insert Grade				Speed SFM			Feed IPT
		Carbide	Cermet	Diamond	Ceramic	.002-.050	.050-.125	.125 and over	
Grey Cast Iron	<.250 Bhn	ACK100				700-1250	625-1125	590-925	.004-.014
		ACK200				700-1050	625-925	590-900	.004-.014
		ACK300				600-950	575-875	550-850	.004-.014
					SN2100K	2250-2750	1750-2250	1250-1750	See Cutter
					SN2000K	3000-4200	2500-3500	2300-3300	See Cutter
		G10E				500-800	475-750	425-725	.004-.010
	>.250 Bhn	ACK100				600-1000	625-925	590-850	.004-.014
		ACK200				600-950	525-825	490-800	.004-.014
		ACK300				500-850	475-775	450-750	.004-.014
					SN2100K	1750-2250	1250-1750	1250-1750	See Cutter
				SN2000K	2000-3000	1800-2800	1500-2500	See Cutter	
	G10E				400-700	375-650	325-625	.004-.009	
Ductile Iron	~.320 Bhn	ACK200				600-925	550-875	490-800	.004-.012
		ACK100				600-1000	625-925	590-850	.004-.012
		ACK300				550-825	550-825	450-750	.004-.012
					SN2100K		1750-2250	1250-1750	See Cutter
Aluminum, Brass, Copper				DA2200/DA1000		3500-10000	3200-8000	2800-6000	.003-.006
		DL1000				1500-4500	1475-4200	1275-4100	.004-.014
		H1				1500-3800	1300-3700	1200-3600	.004-.014
		G10E				1250-3500	1150-3100	1050-2900	.004-.015
High Silicone Aluminum				DA2200/DA1000		1800-6500	1700-5500	1600-5000	
		DL1000				1075-3100	950-2950	850-2500	.0035-.0085
		H1				1000-3000	900-2500	800-2000	.0035-.0085
		G10E				900-2900	800-2400	700-1900	.0035-.009

*NOTE: THESE SPEEDS ARE BASED ON 2/3 THE DIAMETER OF THE CUTTER ENGAGED.

*NOTE: THESE SPEEDS ARE BASED ON 2/3 THE DIAMETER OF THE CUTTER ENGAGED.



DECIMAL CONVERSION-TAP DRILL CHART

Inch-Wire	Decimal	Tap Size	Prob.% Thread	Inch-Wire	Decimal	Tap Size	Prob.% Thread	Inch-Wire	Decimal	Tap Size	Prob.% Thread	Inch-Wire	Decimal	Tap Size	Prob.% Thread
.1mm	.0039			45	.0820			5	.2055			29/64	.4531	1/2-20	65-72
.2mm	.0079			44	.0860			4	.2090			15/32	.4688	M14x2	76-81
.3mm	.0118			43	.0890	4-40	65-71	3	.2130	1/4-28	72-80	12mm	.4724		
80	.0135			42	.0935	4-48	61-68	7/32	.2188			31/64	.4844	9/16-12	68-72
79	.0145			3/32	.0938			2	.2210			1/2	.5000		
1/64	.0156			41	.0960			1	.2280			13mm	.5118		
.4mm	.0157			40	.0980	M3x.5	70-79	A	.2340			33/64	.5156	9/16-18	58-65
78	.0160			39	.0995			15/64	.2344			17/32	.5312	5/8-11	75-79
77	.0180			38	.1015	5-40	65-72	6mm	.2362			35/64	.5469	M16x2	76-81
.5mm	.0197			37	.1040	5-44	63-71	B	.2380			14mm	.5512		
76	.0200			36	.1065	6-32	71-78	C	.2420			9/16	.5625		
75	.0210			7/64	.1094			D	.2460			37/64	.5871	5/8-18	58-65
74	.0225			35	.1100			1/4	.2500			15mm	.5906		
.6mm	.0236			34	.1110			F	.2570	5/16-18	72-77	19/32	.5938		
73	.0240			33	.1130	M3.5x.6 6-40	72-81 69-77	G	.2610			39/64	.6094		
72	.0250			32	.1160			17/64	.2656	M8x1.25	74-80	5/8	.6250		
71	.0260			3mm	.1181			H	.2660			16mm	.6299		
.7mm	.0276			31	.1200			I	.2720	5/16-24	67-75	41/64	.6406		
70	.0280			1/8	.1250			7mm	.2756			21/32	.6562	3/4-10	68-72
69	.0292			30	.1285	M4x.7	74-82	J	.2770			17mm	.6693		
68	.0310			29	.1360	8-32 8-36	62-69 70-78	K	.2810			43/64	.6719		
1/32	.0312			28	.1405			9/32	.2812			11/16	.6875	3/4-16 M20x2.5	71-77 74-78
.8mm	.0315			9/64	.1406			L	.2900			45/64	.7031		
67	.0320			27	.1440			M	.2950			18mm	.7087		
66	.0330			26	.1470			19/64	.2969			23/32	.7188		
65	.0350			25	.1495	10-24	69-75	N	.3020			47/64	.7344		
.9mm	.0354			24	.1520			5/16	.3125	3/8-16	72-77	19mm	.7480		
64	.0360			23	.1540			8mm	.3150			3/4	.7500		
63	.0370			5/32	.1562			O	.3160			49/64	.7656	7/8-9	72-76
62	.0380			22	.1570			P	.3230			25/32	.7812		
61	.0390			4mm	.1575			21/64	.3281			20mm	.7874		
1mm	.0394			21	.1590	10-32	68-76	Q	.3320	3/8-24 M10x1.5	71-79 76-82	51/64	.7969		
60	.0400			20	.1610			R	.3390			13/16	.8125	7/8-14	62-67
59	.0410			19	.1660	M5x.8	69-77	11/32	.3438			21mm	.8268		
58	.0420			18	.1695			S	.3480			53/64	.8281	M24x3	72-76
57	.0430			11/64	.1719			9mm	.3543			27/32	.8438		
56	.0465			17	.1730			T	.3580			55/64	.8594		
3/64	.0469	0-80	71-81	16	.1770	12-24	66-72	23/64	.3594			22mm	.8661		
55	.0520			15	.1800	12-28	70-78	U	.3680	7/16-24	70-75	7/8	.8750	1-8	73-77
54	.0550			14	.1820			3/8	.3750			57/64	.8906		
53	.0595	1-72	59-67	13	.1850			V	.3770			23mm	.9055		
1/16	.0625	M2x.4	72-79	3/16	.1875			W	.3860			29/32	.9062		
52	.0635			12	.1890			25/64	.3906	7/16-20	65-72	59/64	.9219	1-12	67-72
51	.0670			11	.1910			10mm	.3937			15/16	.9375	1-14	61-67
50	.0700	2-56 2-65	62-69 70-79	10	.1935			X	.3970			24mm	.9449		
49	.0730			9	.1960	M6x1	76-84	Y	.4040	M12x1.75	69-74	61/64	.9531		
48	.0760			5mm	.1968			13/32	.4062			31/32	.9688		
5/64	.0781	3-48	70-77	8	.1990			Z	.4130			25mm	.9842		
47	.0785			7	.2010	1/4-20	70-75	27/64	.4219	1/2-13	73-78	63/64	.9844	1-1/8-7	72-76
2mm	.0787			13/64	.2031			11mm	.4331			1	1.000		
46	.0810	M2.5x.45	69-77	6	.2040			7/16	.4375						



TECHNICAL TERMS OF TWIST DRILLS

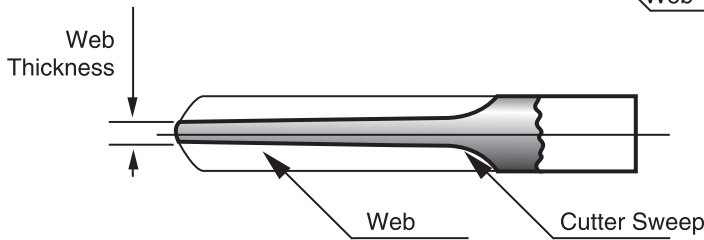
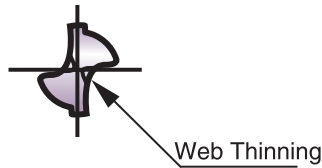
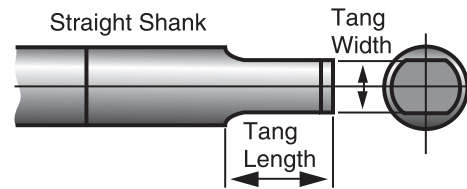
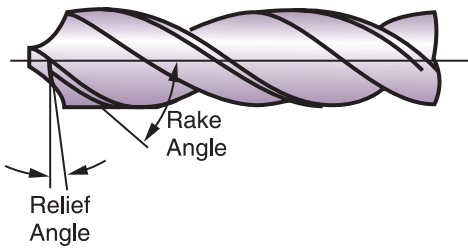
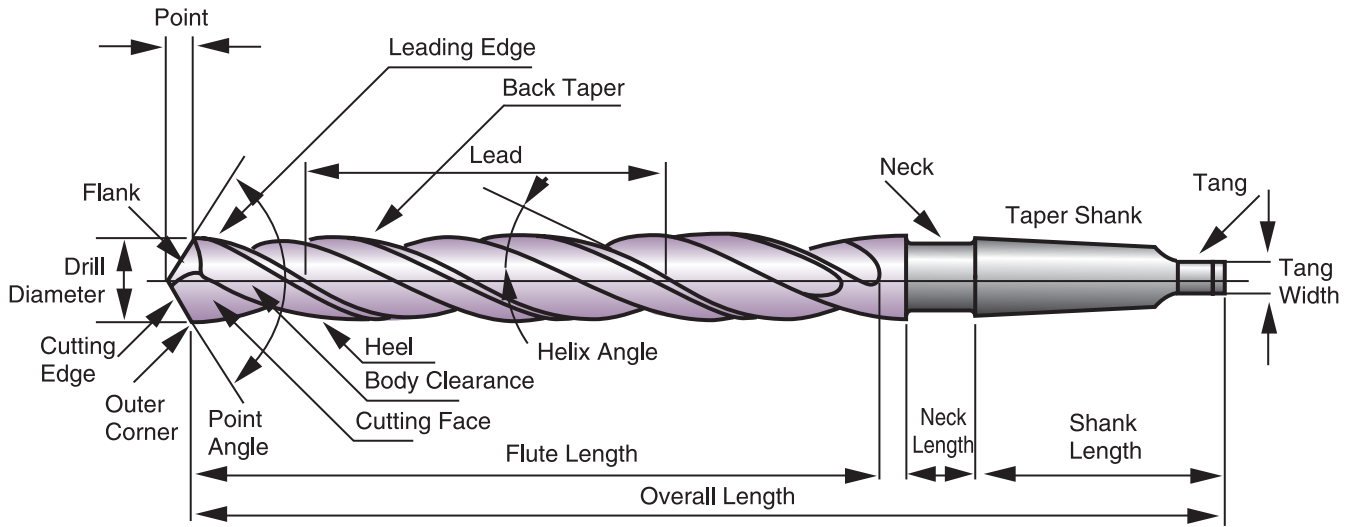

A:B or A/B=Flute Width Ratio

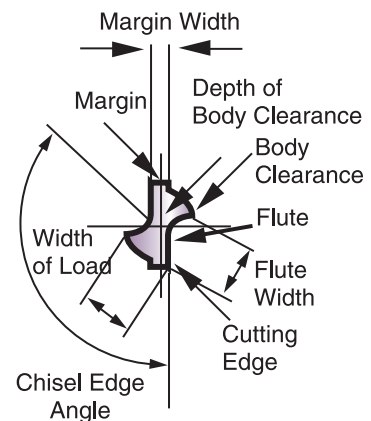
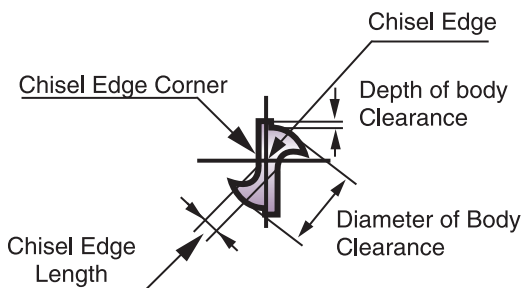

■ CHUCKING

Type of Chuck

- Collet type holders with thrust bearings are recommended.
- For KDS drills, when using an internal coolant supply, use a very rigid chuck with either an inducer or through spindle coolant source.
- Conventional holders such as keyless chucks cannot be used because the gripping strength is limited.
- Collet holders should be cleaned periodically with oil to remove small chips.

Chuckling Position

- The entire flute length must protrude from the chuck.
- At maximum hole depth, the length of flute protruding from the hole must be at least 1 to 1.5 times the drill diameter.
- Radial run out at the drill tip must not exceed .001 in.

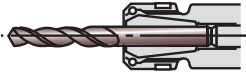

Correct chucking with spring collet.



Chips cannot be removed if the flute is chucked.

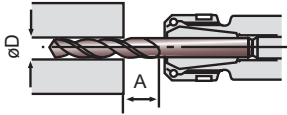

Dimension A should be 1 to 1.5 times drill diameter (D).

■ MACHINE

- Machine tools must have sufficient power and thrust resistance. Refer to the table below when selecting suitable machines.
- Rigid machines such as machining centers or NC turning machines are recommended.
- Machines designed for HSS drills or radial drilling machines are not recommended.

MDS

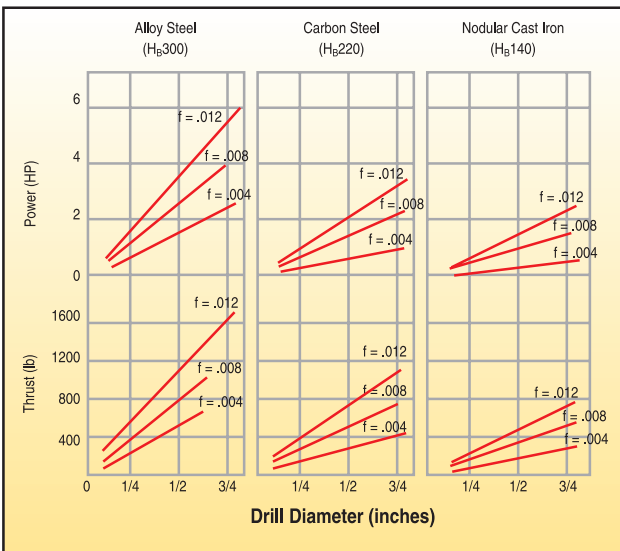

■ CUTTING FLUID

Type of Lubricant

- For heavy duty cutting, emulsion type oil containing an extreme pressure additive is recommended.
- Other fluids may also be used with no difficulty.
- Neat oil can be used effectively with the solid carbide MDS drills for low speed drilling (up to 130 SFM).
- If the work surface becomes hard or blue in color, decrease the RPM and use neat oil.

Application of Lubricant

- Cutting fluid must be applied to the entrance of the hole when drilling.
- For internal coolant supply, coolant pressure should be at a minimum of 200 psi.
- A volume of 3.0 gal/min at a pressure of 50-75 psi is recommended for external coolant supply.
- A double stream supply of fluid is recommended.

■ WORK CLAMPING AND SUPPORT

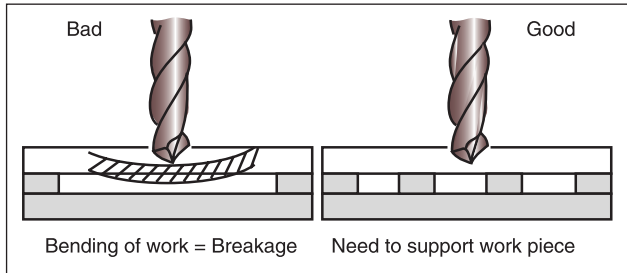
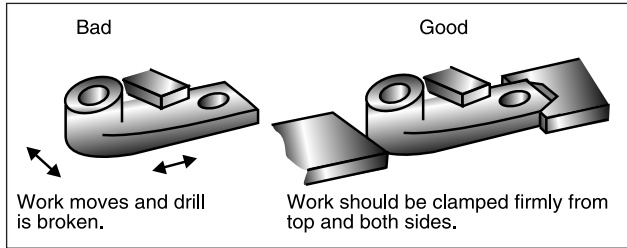

KDS

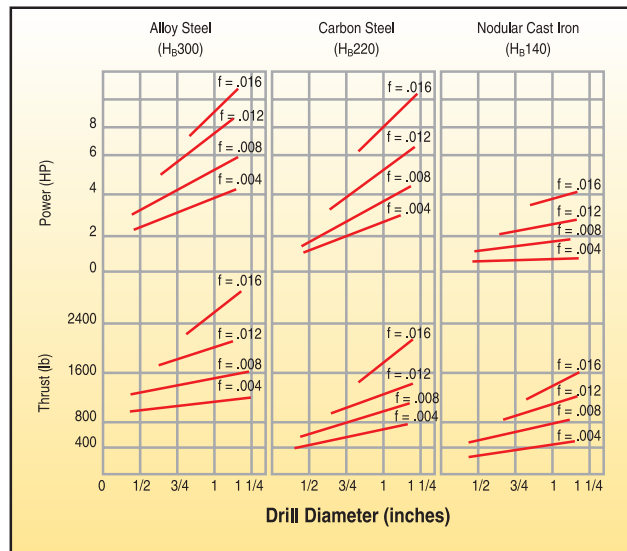

■ TROUBLE

A Drill Wear

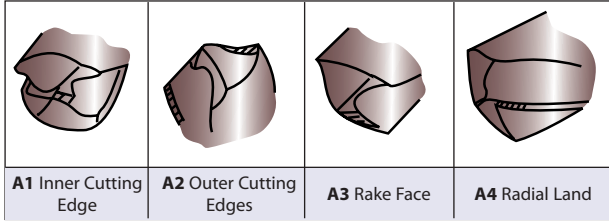

B Drill Chipping

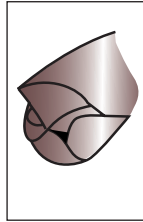

C Cracking

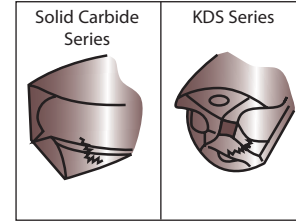

D Body Damage by Chips

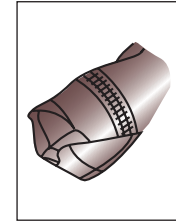

■ COUNTER MEASURE

A1	A2	A3	A4	B	C	D	E	F1	F2	G1	G2	G3	Counter Measure
•													Larger clearance angle near drill center.
			•	•			•	•				•	The protruding length of drill should be shortened as much as possible without constricting chip flow.
	•												Increase clearance angle at the outer cutting edge.
	•	•	•		•								The interval between regrinding of drills should be shortened.
			•	•	•		•	•				•	Larger back taper and narrower width of radial land (Fig. 1).
			•	•		•	•					•	Lip height distance and run out of center cutting edges should be within .0008" ~ .001".
				•									Edge treatment should be larger.
				•									Clearance angle should be reduced.
						•	•		•				Expand the flute width (Fig. 2). Flute length should be maintained (target length is 1.5 L/D).
												•	Point angle should be increased (Fig. 3).
							•						The helical angle should be reduced (when it is used in horizontal machine).
							•						The diameter of body should be smaller (using in horizontal machine, A type drill) (Fig. 4).
													• Edge treatment should be smaller.
•	•	•		•	•	•	•	•				•	• The feed rate should be decreased.
					•	•		•	•			•	Cutting speed should be decreased.
													• The feed rate should be increased.

(Fig. 1)

Bigger back taper
Narrower width of radial lands

(Fig. 2)

Expand flute width

(Fig. 3)

140°
150°

(Fig. 4)

Outside dia. of body should be .020" ~ .040" smaller than the drill dia.



E Breakage

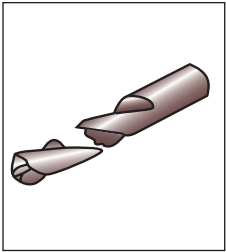

F Trouble During Operation

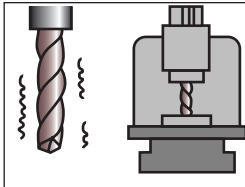

F1 Chattering or Odd Noises

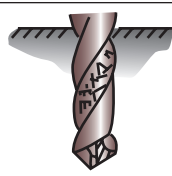

F2 Chip Packing

G Trouble With Hole Accuracy

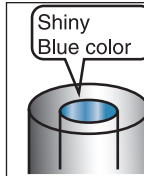

G1 Work Hardening



G2 Unstable Accuracy

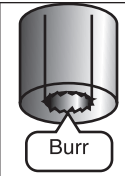

G3 Burrs at the Exit

• **MACHINE**...A, B, C, E, F1

Is there any excessive vibration or odd noise during operation?

• **CHUCKING OF DRILL**...A, B, C, E, F1

Is the rigidity of the drill chuck enough? (Fig. 5)

Is there any dust or scratches inside the drill chuck? (Fig. 6)

Is the run out of the drill too great when it is held in the drill chuck? (Fig. 7)

The drill point should be within 0.001" maximum of the center of the work piece (when the work rotates) (Fig. 8)

Technical Guidance

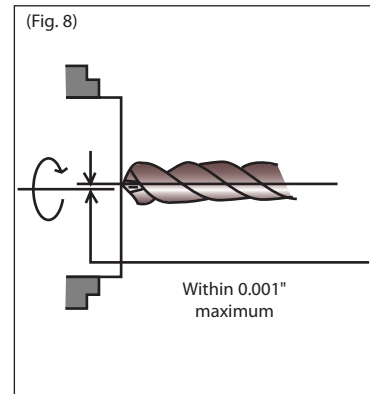
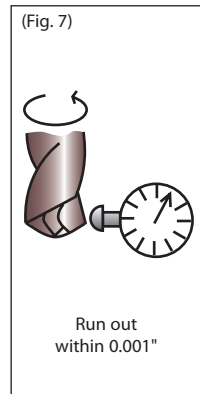
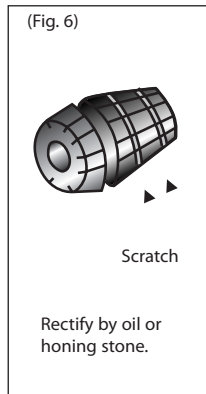
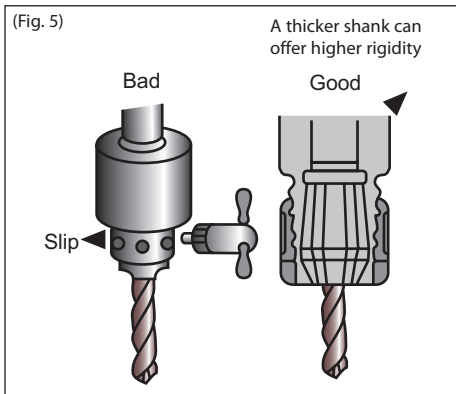

• **CUTTING FLUID**...A, C, E, G1

Make sure cutting fluid is supplied adequately to the entrance of drill hole.

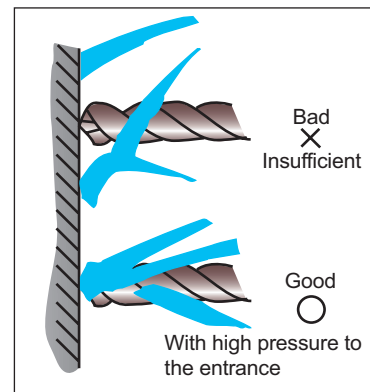
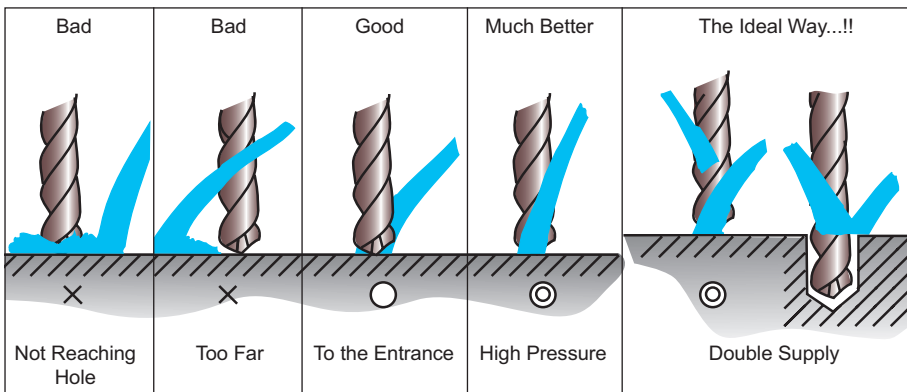

Numerical

00-__	524
20-__	524
2MD-CNMA	158
2MD-DNMA	161
2MD-SNMA	164
2MD-VNMA	168
2NC-CCGA	171
2NC-CCGT	172
2NC-CNGA	158
2NC-DCGA	173
2NC-DCGT	174
2NC-DNGA	161
2NC-DNGG	162
2NC-SNGA	164
2NC-VBGA	179
2NC-VCGA	180
2NC-VNGA	169
2NU-CCGA	171
2NU-CCGE	171
2NU-CCGT	172
2NU-CPGA	172
2NU-DCGA	173
2NU-DCGT	174
2NU-SNGA	164
2NU-VBGA	179
2NU-VNGA	169
3MD-TNMA	166
3NC-TNGA	167
3NC-TPGA	177
3NU-TCGA	175
3NU-TPG	176
3NU-TPGA	177
3NU-WNGA	170
4NC-CNGA	158-159
4NC-CNGG	159
4NC-DNGA	161
4NC-DNGG	162
4NC-VNGA	169
62-__	524
6NC-TNGA	167
6NC-WNGA	170
76-__	563

A

A-DTR	243
AECT	344
ALMT PCD Reamer	533-538
A-MCKN	244
A-MCLN	244
A-MDQN	245
A-MDUN	245
A-MTFN	246
A-MVUN	246
A-MWLN	247
AND	524
ANH	524
ANT	524
APET	392
APG	420
APMT	392
A-SCFP	248
A-SCLC	248
A-SCLP	249
A-SDUC	249
A-SDUP	250
A-SDXP	250
ASM	436

A-STFC	251
A-STFP	251
A-SVQB	252
A-SVUB	252
A-SWLP	253
AXET	334-337, 340-341,396
AXMT	334-337, 340-341,396

B

BCTJP	268
BMCLN	265
BMDLN	265
BMSKN	265
BMWLN	266
BNBP	438
BNB-R	271
BNBX	272
BNGG	312
BNGNT	181,312
BNGS	312
BNTT	181, 312
BRC	412
BSCLO	266
BSDJO	267
B-SDUC	260
BSME	273-274
BSTJO	267
BSSKO	267
BSWJO	268
BTR	139, 228

C

CCGT	87-89, 172
CCKN	205
CCLN	205-206
CCMA	93
CCMT	90-93, 185, 248, 254, 256, 258, 260
CCMX	186
CDJN	206
CGA	146,304
CHE	419
CHG	421
CKBB	237
CKBE	238
CKBR	235
CKBSR	235
CNG	152,160
CNGA	152,159
CNGG	18, 159
CNGX	152,160
CNMA	30, 152, 158, 182
CNMG	19-29
CNMM	29-30
CNMN	152
CNMX	152, 182-183
CPEW	94,187
CPG	186, 421
CPGA	172, 187
CPGT	94
CPMA	97
CPMT	95-96
CPMX	186
CRDC	206
CRDN	207
CRGN	207
C-SCLC	258
CSCLO	269
CSDN	207

CSKN	208
CSNH	420
CSRN	208
CSSN	208
CSTJO	269
C-STUB	257
C-STUP	258
CSWJO	269
CTHSK	560
CTL	139,314
CTR	139,314

D

DCGA	173, 187
DCGT	98-101, 174
DCLN	203, 262, 318,323
DCRN	319
DCMA	103
DCMT	101-103, 187
DCMX	188
DCRN	318
D-DCLN	262
D-DDQN	262
D-DDUN	262
D-DVUN	263
D-DWLN	263
DDJN	203,319
DDNN	319
DFC	364-367
DGC	360-363
DNF	420
DNG	153, 162
DNGA	152, 161-162
DNGG	31, 162
DNJG	31
DNMA	41, 161, 183
DNMG	32-41
DNMX	34, 153, 183, 184
DNX	370-371
DPG	422
DPMT	104
DPW	422
D-SCLC	260
D-SCLP	260
D-SDUC	260
D-STUC	261
D-STUP	261
D-SVUB	261
D-SVZB	261
DTFN	203,320
DTGN	204
DTR-C	202
DTR-Q	202
DVJN	320
DVVN	320
DWLN	204, 263,321, 323

E

EHG	423
ER	545-546, 556-558
E-SCLC	256
E-STFC	257
E-STFP	257

F

FM	411
FMU	410
FPG	423



G		
GCM	144-145, 296-297	
GFV	369	
GITR/L	302	
GND	294-295	
GNDF	285, 290-291	
GNDI	291	
GNDL	284, 288-289	
GNDM	283, 287	
GSX (Inch)	429	
GSX (Metric)	430	
GSXB (Inch/Metric)	431-432	
GSXVL	433-434	
GWB	146, 181, 303	
GWC	298	
H		
HBB	271, 272	
HBSM	273-274	
HBX	270, 272	
HF	402-406	
I		
ISG3400TWK-WS	551	
ISO (Spindle Clean)	563	
K		
KBMF	238	
KBMG	238	
KBMX	238	
L		
LNEX	346	
LNGX	155, 369	
LNMX	349	
LTER	305	
M		
M_	559	
M_x_DIN	559	
MCGN	209	
MCKN	209, 244	
MCLN	209, 244, 321	
MCMN	210	
MCRN	210	
MDE	195	
MDF	472-473	
MDJN	210	
MDPNN	211	
MDQN	212	
MDSS	485	
MDUS	484	
MDW-GS2	445-449	
MDW-GS4	450-453	
MDW-HGS3	455-459	
MDW-HGS5	460-465	
MDW-HGS8	466-469	
MDW-NHGS	486-487	
MDW-PHT	480	
MDW-PHV	479	
MDW-XHV	476-478	
MLDH	482-483	
MRGN	211	
MS	377	
MSDNN	212	
MSRN	212	
MSSN	212	
MSX	374-376	
MTAN	213	
MTENN(S)	213	
MTGN	213	
MTJN	214	
MVJN	214	
MVVNN	215	
MWLN	215	
N		
NF-CCMT	185	
NF-CCMX	186	
NF-CNMA	182	
NF-CNMX	182-183	
NF-CPGA	187	
NF-CPMX	186	
NF-DCGA	187	
NF-DCMT	187	
NF-DCMX	188	
NF-DNMA	183	
NF-DNMX	183-184	
NF-LDEN	404, 406	
NF-SDC	420	
NF-SECW	417	
NF-SNEW	407, 408	
NF-SPG	188	
NF-TBGE	189	
NF-TCMX	189	
NF-TEEN	419	
NF-TNMX	184	
NF-TPG	190	
NF-TPGA	191	
NF-TPMT	192	
NF-TPMX	192	
NF-VCMA	193	
NF-VCMT	193	
NF-VCMX	193	
NF-VNMA	184	
NF-VNMX	185	
NPDB	439	
NS-CNMA	158	
NS-DNMA	161	
NS-TNMA	166	
NS-VNMA	168	
NU-CCGA	171	
NU-CCGE	172	
NU-CNMA	158	
NU-CPGA	172	
NU-DCGA	173	
NU-DCGD	173	
NU-DNMA	161	
NU-SNMA	164	
NU-SPG	174	
NU-TNMA	166	
NU-TPG	176	
NU-TPGA	177-178	
NU-TPGX	177	
NU-VBGA	179	
NU-VCGA	180	
NU-VNMA	168	
NU-WNMA	170	
NU-ZNEX	180	
O		
ONET	362-363	
ONMT	362-363	
P		
PBV	141, 233	
PCT	513-514	
PCLC	226, 227	
PDJC	226, 227	
PDL	513-514	
PHT	480	
PHV	479	
PSC	315-325	
PWC	425	
PWS	348-350	
R		
RCGA	174	
RCGX	154, 174	
RCMT	105	
RCMX	105	
RDET	380-383, 397	
RDHX	412	
RF	407	
RGMN	419	
RM	409	
RNG	153, 163	
RNMA	43	
RNMG	42-43	
RPGX	154	
RS	30-232	
RSX	380-383, 397	
S		
S- (Wrench)	561	
SBN	310	
SBT-R	228	
SBU	310	
SC(Wrench)	561	
SCAC	218	
SCCH	541-543	
SCGT	106	
SCLC	218, 321, 323	
SCMT	106-109	
SCNC	218	
SCT	228	
SDAC	219	
SDC	420	
SD-ER	557-558	
SDEW	377	
SDJC	219, 322	
SDKN	423	
SDMW	377	
SDNC	219	
SDP	372	
SDPC	220	
SEC	423	
SEET-AGSN	415-417	
SEET-AGSR	356	
SEKN	423	
SEMR	423	
SEMT-AGSN	415-417	
SEMT-AGSR	356	
SER/L	300-301	
SFEN	418	
SFKN	418	
SFKR	418	
SFT	229	
SG	145, 155, 182, 301-302	
SGIT	302	
SHPMC	541	
S-HSK (Wrench)	561	
SJB	272	
SM (Key/Wrench)	617	
SM (Drive Key)	615	
SMDH	491-499	
SMDT	491-499	



SNB	437
SNEN	409, 411
SNEW	407, 410
SNEX	372
SNG	44, 153, 165, 420
SNGA	153, 164
SNGX	165
SNMA	56, 164
SNMG	45-54
SNMM	54-55
SNMN	56, 153, 420
SNMT	361-363, 371
SNMX	153, 372
SNP	44
SOET	353
SOMT	353
SPBR	233
SPCH	422
SPG	110, 155, 174, 188
SPGA	175
SPGG	110
SPMN	113, 422
SPMR	112-113
SPMT	111-112, 386, 388
SRA	517, 521
SRB	520, 521
SRD	520
SRG	518
SRKC	562
SRKG	517, 521
SRL	517, 519
S-SCLC	254
SSEH	552-553
SSKC	324
SSMH	554-555
SSR/L	300
SSSC	544
S-STUB	254
S-STUP	253
ST	547-550
STAC	221, 224
STCP	562
STFC	324
STFH	311
STFSR/L	311
STGC	224
STIR	305
STSK	562
SVAB	221
SVHB	322
SVJB	222, 322
SVJC	222, 322
SVNB	223
SVVC	223

T

TBGE	175, 189
TBGT	114-115
TCGT	115-116
TCMA	118
TCMT	116-118
TCMX	189
TECN	419, 421
TEEN	419, 421
TEGE	129
TEGN	129, 189
TEKN	419, 421
TGA	299

TME	149, 306
TMI	150, 307
TNG	59, 154
TNGA	154, 167
TNGG	57
TNMA	69, 166
TNMG	60-68
TNMM	68
TNMX	184
TNPR/L	57-59
TNPT	149, 307
TPC	421
TPCH	421
TPEE	176
TPG	128, 155, 176, 190
TPGA	177-178, 173, 191
TPGG	112
TPGT	119-121
TPMN	128, 421
TPMR	127
TPMT	121-124, 192
TPMX	192
TRM	70
TSX	346-347, 399
TUE	149, 306
TWE	149, 306

U

UFO	418
UFOF	418
UFOR	419
UW	418

V

VBGA	179
VBGT	130
VBMA	132
VBMT	131-132
VCGT	133-134
VCMA	180, 193
VCMT	135-136, 193
VCMX	194
VNGA	154, 169
VNGG	71
VNMA	77, 168, 184
VNMG	71-77
VNMX	185
VPMA	194

W

WBGT	137-138
WBMF	389-390
WBMR	386-388
WBMX	194
WCFH	308-310
WCFL	147, 309
WCFN	147, 309
WCFR	147, 309
WCFS	309
WDX	502-511
WEX-E	332, 336
WEX-F	333, 337
WEX-EW	332, 336
WEX-M	396
WEX-R	333, 337
WFX	351-353
WGC	414-417
WGX	356-359

WMM	391-392
WNGA	154, 170
WNGG	77
WNMA	86, 170
WNMG	78-86
WRX	338-341
WRCX	384-385
WWLN	216

X

XNEU	358-359
XNMU	365
XOEW	353
XEEW	356, 414

Z

ZNMT	390
ZPGU	388





SUMITOMO

CARBIDE - CBN - DIAMOND

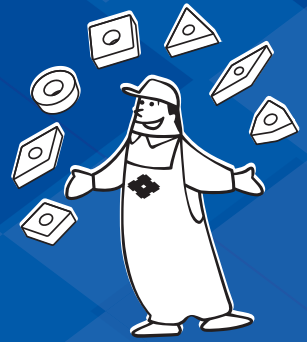

Sumitomo Electric Carbide, Inc.

Headquarters

1001 Business Center Drive
Mount Prospect, IL 60056-2181
P.O. Box 545, Mt. Prospect, IL 60056-0545
Phone: (800) 950-5202
Phone: (847) 635-0044
Fax: (847) 635-7866
<http://www.sumicarbide.com>

Detroit Branch

14496 Sheldon Road #230
Plymouth, MI 48170
Phone: (800) 239-5177
Phone: (734) 451-0200
Fax: (734) 451-5338

Sumitomo Electric Tool Engineering Center

5637 S. Westridge Drive
New Berlin, WI 53151
Phone: (800) 950-5202

Huntsville Branch

6700 Odyssey Drive
Suite 211
Huntsville, AL 35806
Phone: (256) 971-1203
Fax: (256) 971-1205

Indiana Branch

595 S. Emerson Avenue
Suite 100
Greenwood, IN 46143
Phone: (317) 859-1601

Torrance Branch

21241 South Western Avenue
Suite 120
Torrance, CA 90501
Phone: (800) 950-5202
Fax: (310) 782-0211

Sumitomo Carbide Canada, Inc.

150 Research Lane
Unit #210
Guelph, Ontario N1G 4T2
Canada
Phone: (519) 265-6050
Phone: (844) 211-6050

